

LR74 Free Space Radar



24 GHz Radar (FMCW) Level Transmitter for agitated and corrosive liquids

- ▶ Process conditions up to +200°C / +392°F and 100 barg / 1450 psig
- ▶ Quick coupling housing and dual sealing with METAGLAS® design
- ▶ Proven PTFE and PEEK Drop antenna with flange protection

Equipment should be installed, operated, serviced, and maintained only by qualified personnel.

No responsibility is assumed by Schneider Electric for any consequences arising from the use of this material.

1 Product features	3
<hr/>	
1.1 The FMCW radar level transmitter for agitated and corrosive liquids	3
1.2 Applications	5
1.3 Product family	6
1.4 Measuring principle.....	9
2 Technical data	11
<hr/>	
2.1 Technical data.....	11
2.2 Measuring accuracy	18
2.3 Minimum power supply voltage	20
2.4 Guidelines for maximum operating pressure.....	22
2.5 Dimensions and weights	26
3 Order information	41
<hr/>	
3.1 Order code	41

1.1 The FMCW radar level transmitter for agitated and corrosive liquids

This device is a non-contact radar level transmitter that uses FMCW technology. It measures distance, level and volume of liquids and pastes. It is ideal for measuring the level of corrosive liquids in agitated tanks.

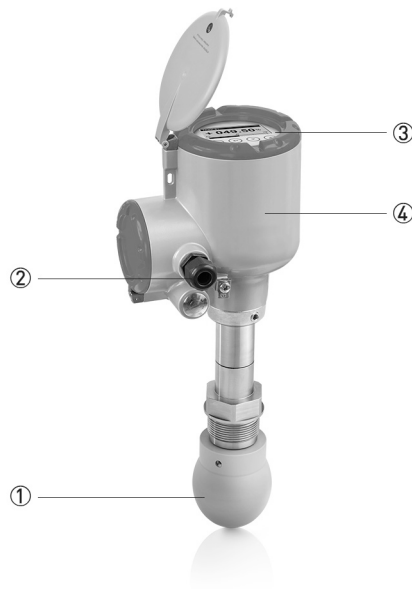

- ① Drop antenna design with a small beam angle for larger measuring distances
- ② 2-wire 24 GHz radar level transmitter, HART® 7-compatible
- ③ Large, backlit LCD screen with 4-button keypad can be used with a bar magnet without opening the housing cover. The software has a quick setup assistant for easy commissioning. 12 languages are available.
- ④ Aluminium or stainless steel housing

Highlights

- Accuracy ± 2 mm / ± 0.08 "
- Flange plate protection and Drop antennas made of PTFE or PEEK for condensing and corrosive applications
- Ellipsoidal shape and smooth surface minimize scaling on the Drop antenna
- Metallic Horn (316L) DN200 / 8" for measuring distances up to 100 m / 328 ft. Can be equipped with purging system if required.
- Antenna extensions to suit any nozzle length
- Quick coupling system permits removal of the converter under process conditions and 360° rotation to make the display screen easier to read
- Diagnosis functions according to NAMUR NE 107
- Conforms to NAMUR Recommendations NE 21, NE 43 and NE 53
- Measures non-Ex applications up to $+700^{\circ}\text{C}$ / $+1292^{\circ}\text{F}$ (for example: molten salt in solar plants)
- 2-wire loop-powered 24 GHz transmitter (LPR and TLPR) for liquids

- Can measure in fast moving processes (≤ 60 m/min / 196.85 ft/min)

Industries

- Chemical market
- Oil & Gas
- Petrochemicals
- Power
- Steel

Applications

- Agitated liquids in tanks
- High accuracy applications where ± 2 mm / 0.08" is specified
- Long-range liquid level applications up to 100 m / 328 ft
- Fast moving processes (≤ 60 m/min / 196.85 ft/min)

1.2 Applications

1. Level measurement of liquids

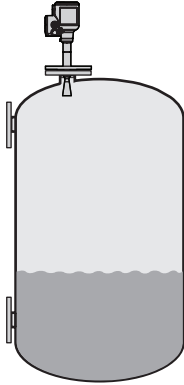

The level transmitter can measure the level of a wide range of liquid products on a large variety of installations within the stated pressure and temperature range. It does not require any calibration: it is only necessary to do a short configuration procedure.

2. Volume (mass) measurement

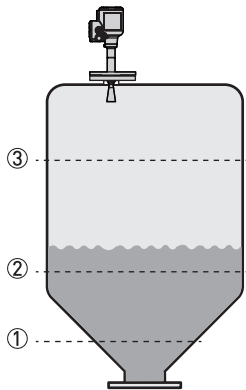

A strapping table function is available in the configuration menu for volume or mass measurement. Up to 50 volume (mass) values can be related to level values. For example:
 Level ①= 2 m / Volume ①= e.g. 0.7 m³
 Level ②= 10 m / Volume ②= e.g. 5 m³
 Level ③= 20 m / Volume ③= e.g. 17 m³

This data permits the device to calculate (by linear interpolation) volume or mass between strapping table entries.

PACTware™ software and a DTM (Device Type Manager) is supplied free of charge with the device. This software permits the user to easily configure the device with a computer. It has a conversion table function with a large number of tank shapes.

1.3 Product family

LevelWave LR01 (10 GHz) for liquids in storage and process applications



This 10 GHz 2-wire FMCW radar level transmitter measures distance, level, volume, mass and flow rate of liquids and pastes. It is ideal for corrosive products with its PP or PTFE antenna options. It features unique PP and PTFE antennas for aggressive products. The device is able to measure distances up to 30 m / 98.4 ft in process conditions up to +250°C / +482°F and 40 barg / 580 psig.

The device agrees with SIL2 requirements for safety-related systems (as per IEC 61508). Output options include HART®, FOUNDATION™ fieldbus and PROFIBUS PA industrial communication protocols.

LR54 Free Space Radar (24 GHz) for liquids in basic process applications



Designed for basic liquid applications, this market entry 24 GHz 2-wire FMCW radar transmitter provides accurate readings even in fast moving processes, in closed tanks or in the open air like rivers or dams. Its proven PP Drop antenna is insensitive to condensation.

The LR54 can measure in process conditions with temperatures up to +130°C / +266°F and pressures up to 16 barg / 232 psig. The antenna options permit to measure distances up to 100 m / 328 ft. The device can be installed in high nozzles (≤ 1 m / 3.28 ft) when it is fitted with antenna extensions.

LR74 Free Space Radar (24 GHz) for agitated and corrosive liquids



This 24 GHz FMCW radar level transmitter is designed for liquids in harsh environment like tanks with agitators containing corrosives or in non-Ex applications with extremely high process temperatures, like molten salt in solar plants (+700°C / +1292°F). For toxic and dangerous products, the use of a Metaglas® second sealing barrier is recommended.

The PTFE and PEEK Drop antennas have optional flange plate protection for corrosive media. Heating and cooling systems prevent from crystallization inside the Metallic Horn antennas. The device measures distances up to 100 m / 328 ft and can be installed in high nozzles (≤ 1 m / 3.28 ft) when fitted with antenna extensions. Standard process conditions up to +200°C / 392°F; 100 barg / 1450 psig (higher on request).

LR75 Free Space Radar (80 GHz) for liquids in narrow tanks with internal obstructions



The small beam angle and negligible dead zone of this 80 GHz FMCW radar level transmitter makes it the premium choice for liquids in small and narrow tanks with internal obstructions like agitators or heating coils, as well as tanks with long nozzles. It can even measure through tank roofs made of non-conductive material (e.g. plastic, fiberglass or glass). The flush-mounted PEEK Lens antenna (no tank intrusion) is insensitive to deposit.

There is an extensive choice of process connections starting from $\frac{3}{4}$ ". Flanges have an optional PEEK plate protection for corrosive tank contents. The LR75 operates in process conditions with temperatures up to +150°C / +302°F and pressures up to 40 barg / 580 psig. It measures distances up to 100 m / 328 ft and a 112 mm / 4.4" extension is available for high nozzles.

LR64 Free Space Radar (24 GHz) for solids from granulates to rocks



By combining high signal dynamics and FMCW radar technology, this market-entry 24 GHz radar device measures accurately and reliably the level of solids like stone, plastic granulates or coffee beans. No need for expensive antenna aiming kits or purging systems; the proven Drop antenna design minimizes scaling and is not affected by the angle of repose.

It operates in process conditions with temperatures up to +130°C / +266°F and pressures up to 16 barg / 232 psig. The antenna options permit the device to measure distances up to 100 m / 328 ft.

LR65 Free Space Radar (80 GHz) for powders and dusty atmosphere



Accurate continuous level measurement of fine powders has to deal with a series of issues like dust, low-reflective media, build-up and uneven surfaces. The specific algorithms and high signal dynamics of this 80 GHz FMCW radar transmitter are the key to provide reliable and accurate readings despite these difficult conditions. Thanks to the small beam angle of the flush-mounted Lens antenna, this powerful device handles high and narrow silos even in the presence of internal obstructions.

The LR65 operates in process conditions with temperatures up to +200°C / +392°F and pressures up to 40 barg / 580 psig. It offers an extensive choice of threaded ($\geq 1\frac{1}{2}$ ") and flanged ($\geq \text{DN}50 / 2$ ") process connections. The antenna options permit the device to measure distances up to 100 m / 328 ft. A 112 mm / 4.4" extension is available for high nozzles.

1.4 Measuring principle

A radar signal is emitted via an antenna, reflected from the product surface and received after a time t . The radar principle used is FMCW (Frequency Modulated Continuous Wave).

The FMCW-radar transmits a high frequency signal whose frequency increases linearly during the measurement phase (called the frequency sweep). The signal is emitted, reflected on the measuring surface and received with a time delay, t . Delay time, $t=2d/c$, where d is the distance to the product surface and c is the speed of light in the gas above the product.

For further signal processing the difference Δf is calculated from the actual transmitted frequency and the received frequency. The difference is directly proportional to the distance. A large frequency difference corresponds to a large distance and vice versa. The frequency difference Δf is transformed via a Fast Fourier Transform (FFT) into a frequency spectrum and then the distance is calculated from the spectrum. The level results from the difference between the tank height and the measured distance.

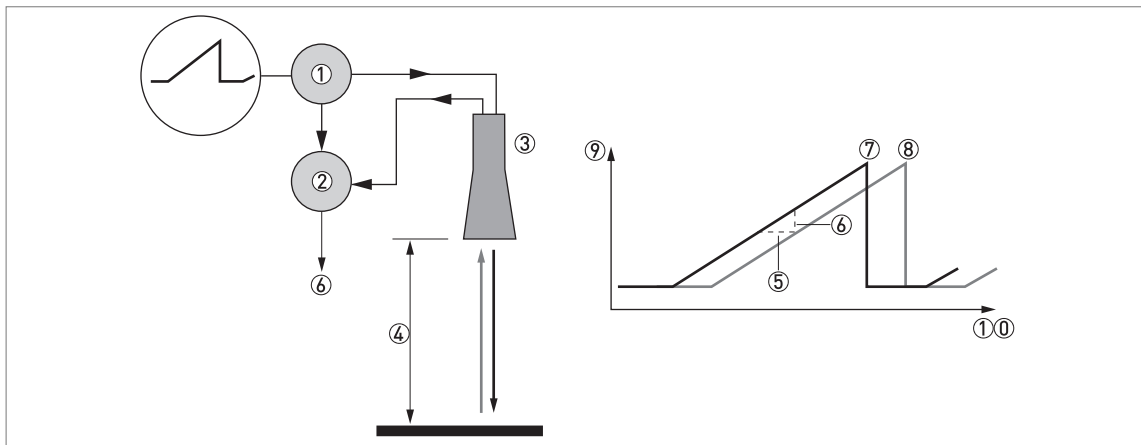

Figure 1-1: Measuring principle of FMCW radar

- ① Transmitter
- ② Mixer
- ③ Antenna
- ④ Distance to product surface, where change in frequency is proportional to distance
- ⑤ Differential time delay, Δt
- ⑥ Differential frequency, Δf
- ⑦ Frequency transmitted
- ⑧ Frequency received
- ⑨ Frequency
- ⑩ Time

Measurement modes

"Direct" mode

If the dielectric constant of the liquid is high ($\epsilon_r \geq 1.4$), the level signal is the reflection on the surface of the liquid.

"TBF Auto" mode

If the dielectric constant of the liquid is low (ϵ_r 1.4...1.5, for long-distance measurement), you must use "TBF Auto" mode to measure level correctly. "TBF Auto" is an automatic mode that lets the device make a selection between "Direct" mode and "TBF" mode. If the device finds a large radar reflection above the "tank bottom area" (the bottom 20% of the tank height), the device will use "Direct" mode. If the device finds a large radar reflection in the "tank bottom area", the device uses TBF mode. This mode can be used only in tanks with flat bottoms or in stilling wells with a reference plate at the bottom.

"Full TBF" mode

TBF = Tank Bottom Following. If the dielectric constant of the liquid is very low ($\epsilon_r < 1.4$), you must use "TBF Full" mode to measure level correctly. The device uses the radar reflection on the bottom of the tank (the signal goes through the liquid). This mode can be used only in tanks with flat bottoms or in stilling wells with a reference plate at the bottom.

2.1 Technical data

- *The following data is provided for general applications. If you require data that is more relevant to your specific application, please contact us or your local sales office.*
- *Additional information (certificates, special tools, software,...) and complete product documentation can be downloaded free of charge from the website.*

Measuring system

Measuring principle	2-wire loop-powered level transmitter; FMCW radar
Frequency range	K-band (24...26 GHz)
Max. radiated power (EIRP)	< -41.3 dBm according to ETSI EN 302 372 (TLPR) and ETSI EN 302 729 (LPR)
Application range	Level measurement of liquids, pastes and slurries
Primary measured value	Distance and reflection
Secondary measured value	Level, volume and mass

Design

Construction	The measurement system consists of a measuring sensor (antenna) and a signal converter
Options	Integrated LCD display [-20...+70°C / -4...+158°F]; if the ambient temperature is not in these limits, then this condition can stop the display
	Straight antenna extensions (length 105 mm / 4.1") Max. extension length, Metallic Horn antenna: 1050 mm / 41.3" Max. extension length, Drop antenna: 525 mm / 20.7"
	Antenna purging system (supplied with a 1/8 NPTF connection)
	Heating / cooling system (with or without the antenna purging system) – only for DN50/2" Metallic Horn antenna (min. DN80/3" flange), DN80/3" Metallic Horn antenna (min. DN150/6" flange), and DN100/4" Metallic Horn antenna (DN200/8" flange)
	PTFE flange plate protection and extension protection (PTFE protective layer for antenna extensions)
	PEEK flange plate protection
	Weather protection
Max. measuring range (antenna)	Metallic Horn, DN40 (1½"): 15 m / 49.2 ft
	Metallic Horn, DN50 (2"): 20 m / 65.6 ft
	Metallic Horn, DN65 (2½"): 25 m / 82 ft – for level chambers
	Metallic Horn, DN80 (3"): 50 m / 164 ft
	Metallic Horn, DN100 (4"): 80 m / 262.5 ft
	Metallic Horn, DN150 (6") and DN200 (8"): 100 m / 328.1 ft
	PTFE or PEEK Drop, DN80 (3"): 50 m / 164 ft
	PTFE Drop, DN100 (4"): 80 m / 262.5 ft
	PTFE Drop, DN150 (6"): 100 m / 328.1 ft
Refer also to "Measuring accuracy" on page 18	
Min. tank height	0.2 m / 8"

Recommended minimum blocking distance	Antenna extension length + antenna length + 0.1 m / 4"
Min. distance for reflection measurement	1 m / 3.3 ft
Beam angle (antenna)	Metallic Horn, DN 40 (1.5"): 17°
	Metallic Horn, DN 50 (2"): 16°
	Metallic Horn, DN 65 (2.5"): not applicable. This antenna option is for level chambers.
	Metallic Horn, DN 80 (3"): 9°
	Metallic Horn, DN 100 (4"): 8°
	Metallic Horn, DN150 (6"): 6°
	Metallic Horn, DN200 (8"): 5°
	PTFE Drop, DN80 (3"): 8°
	PTFE Drop, DN100 (3"): 7°
	PTFE Drop, DN150 (6"): 4°
PEEK Drop, DN80 (3"): 9°	
Display and user interface	
Display	Backlit LCD display
	128 × 64 pixels in 64-step greyscale with 4-button keypad
Interface languages	English, French, German, Italian, Spanish, Portuguese, Chinese (simplified), Japanese, Russian, Czech, Polish and Turkish

Measuring accuracy

Resolution	1 mm / 0.04"
Repeatability	±1 mm / ±0.04"
Accuracy	Standard: ±2 mm / ±0.08", when distance ≤ 10 m / 33 ft; ±0.02% of measured distance, when distance > 10 m / 33 ft. For more data, refer to <i>Measuring accuracy</i> on page 18.
Reference conditions acc. to EN 61298-1	
Temperature	+15...+25°C / +59...+77°F
Pressure	1013 mbara ±50 mbar / 14.69 psia ±0.73 psi
Relative air humidity	60% ±15%
Target	Metal plate in an anechoic chamber

Operating conditions

Temperature	
Ambient temperature	-40...+80°C / -40...+176°F Ex: see supplementary operating instructions or approval certificates
Relative humidity	0...99%
Storage temperature	-40...+85°C / -40...+185°F
Process connection temperature (higher temperature on request)	Metallic Horn antenna: -50...+200°C / -58...+302°F (the process connection temperature must agree with the temperature limits of the gasket material. Refer to "Materials" in this table.) Ex: see supplementary operating instructions or approval certificates
	Drop antenna (PTFE): -50...+150°C / -58...+302°F (the process connection temperature must agree with the temperature limits of the gasket material. Refer to "Materials" in this table.) Ex: see supplementary operating instructions or approval certificates
	Drop antenna (PEEK): -50...+200°C / -58...+392°F (the process connection temperature must agree with the temperature limits of the gasket material. Refer to "Materials" in this table.) Ex: see supplementary operating instructions or approval certificates
Pressure	
Process pressure	Drop antenna (PTFE): -1...40 barg / -14.5...580 psig
	Drop antenna (PEEK): Standard: -1...40 barg / -14.5...580 psig
	Metallic Horn antenna: Standard: -1...40 barg / -14.5...580 psig; Option: -1...100 barg / -14.5...1450 psig
	Subject to the process connection used and the process connection temperature. For more data, refer to <i>Guidelines for maximum operating pressure</i> on page 22.
Other conditions	
Dielectric constant (ϵ_r)	Direct mode: ≥ 1.4 TBF mode: ≥ 1.1
Ingress protection	IEC 60529: IP66 / IP68 (0.1 barg / 1.45 psig)
	NEMA 250: NEMA type 4X - 6 (housing) and type 6P (antenna)
Maximum rate of change	60 m/min / 196 ft/min

Installation conditions

Process connection size	The nominal diameter (DN) should be equal to or larger than the antenna diameter.
	If the nominal diameter (DN) is smaller than the antenna, either: – provide the means to adapt the device to a larger process connection on the tank (for example, a plate with a slot), or – use the same process connection, but remove the antenna from the device before installation and fit it from inside the tank.
Process connection position	Make sure that there are not any obstructions directly below the process connection for the device. For more data, refer to the handbook..
Dimensions and weights	For dimensions and weights data, refer to <i>Dimensions and weights</i> on page 26.

Materials

Housing	Standard: Polyester-coated aluminium
	Option: Stainless steel (1.4404 / 316L) – non-Ex devices only. Ex approvals will be available in the second quarter of 2020.
Wetted parts, including antenna	Metallic Horn antenna: Stainless steel (1.4404 / 316L)
	Standard for Drop antenna: PTFE; PEEK
	Options for PTFE Drop antenna: PTFE flange plate protection and PTFE protective layer for antenna extensions Options for PEEK Drop antenna: PEEK flange plate protection
Process connection	Stainless steel (1.4404 / 316L) – a PTFE or PEEK flange plate protection option is also available for the Drop antenna
Gaskets (and O-rings for the sealed antenna extension option)	PTFE Drop antenna: FKM/FPM (-40...+150°C / -40...+302°F); Kalrez® 6375 (-20...+150°C / -4...+302°F); EPDM (-50°C...+150°C / -58...+302°F) ①
	PEEK Drop antenna: FKM/FPM (-40...+200°C / -40...+392°F); Kalrez® 6375 (-20...+200°C / -4...+392°F); EPDM (-50°C...+150°C / -58...+302°F) ①
	Metallic Horn antenna: FKM/FPM (-40...+200°C / -40...+392°F); Kalrez® 6375 (-20...+200°C / -4...+392°F); EPDM (-50°C...+150°C / -58...+302°F)
Feedthrough	Standard: PEI (-50...+200°C / -58...+392°F – max. range) The feedthrough temperature limits must agree with the temperature limits of the gasket material and antenna type
	Option: Metaglas® (-30...+200°C / -22...+392°F – max. range) The feedthrough temperature limits must agree with the temperature limits of the gasket material and antenna type
Cable gland	Standard: none
	Options: Plastic (Non-Ex: black, Ex i-approved: blue); nickel-plated brass; stainless steel; M12 (4-pin connector)
Weather protection (Option)	Stainless steel (1.4404 / 316L)

Process connections

Thread	G 1½ (ISO 228); 1½ NPT (ASME B1.20.1)
Flange version	
EN 1092-1	Low-pressure flanges: DN50...200 in PN01; Standard flanges: DN50...200 in PN16 (Type B1); DN40...200 in PN40 (Type B1); DN40...150 in PN63 or PN100 (Type B1); others on request Optional flange facings for standard flanges: Types A, B2, C, D, E and F
ASME B16.5	Low-pressure flanges: 2" ... 8" in 150 lb (max. 15 psig); Standard flanges: 1½" ... 8" in 150 lb RF or 300 lb RF; 1½" ... 4" in 600 lb RF; 3" ... 4" in 900 lb RF; 1½" ... 2" in 900/1500 lb RJ; others on request Optional flange facings for standard flanges: FF (Flat Face) and RJ (Ring Joint)
JIS B2220	40...200A in 10K RF; others on request
Other	Others on request

Electrical connections

Power supply	Terminals output – Non-Ex / Ex i: 12...30 V DC; min./max. value for an output of 21.5 mA at the terminals
	Terminals output – Ex d: 16...36 V DC; min./max. value for an output of 21.5 mA at the terminals
Maximum current	21.5 mA
Current output load	Non-Ex / Ex i: $R_L [\Omega] \leq ((U_{\text{ext}} - 12 \text{ V}) / 21.5 \text{ mA})$. For more data, refer to <i>Minimum power supply voltage</i> on page 20.
	Ex d: $R_L [\Omega] \leq ((U_{\text{ext}} - 16 \text{ V}) / 21.5 \text{ mA})$. For more data, refer to <i>Minimum power supply voltage</i> on page 20.
Cable entry	Standard: M20×1.5; Options: ½ NPT; 4-pin male M12 connector
Cable gland	Standard: none
	Options: M20×1.5 (cable diameter: 7...12 mm / 0.28...0.47"); others are available on request
Cable entry capacity (terminal)	0.5...3.31 mm ² (AWG 20...12)

Input and output

Current output	
Output signal	Standard: 4...20 mA
	Options: 3.8...20.5 mA acc. to NAMUR NE 43; 4...20 mA (reversed); 3.8...20.5 mA (reversed) acc. to NAMUR NE 43
Output type	Passive
Resolution	±5 µA
Temperature drift	Typically 50 ppm/K
Error signal	High: 21.5 mA; Low: 3.5 mA acc. to NAMUR NE 43
HART®	
Description	Digital signal transmitted with the current output signal (HART® protocol) ②
Version	7.4
Load	≥ 250 Ω
Digital temperature drift	Max. ±15 mm / 0.6" for the full temperature range
Multi-drop operation	Yes. Current output = 4 mA. Enter Program mode to change the polling address (1...63).
Available drivers	FC475, AMS, PDM, FDT/DTM
PROFIBUS PA (pending)	
Type	PROFIBUS MBP interface that agrees with IEC 61158-2 with 31.25 kbit/s; voltage mode (MBP = Manchester-Coded, Bus-Powered)
Function blocks	1 × Transducer Block Level (TB-Level), 1 × Physical Block (PB), 4 × Analog Input Block (AI), 1 × Totalizer Function Block (TOT)
Device power supply	9...32 V DC – bus powered; no additional power supply required
Polarity sensitivity	No
Basic current	18 mA
FOUNDATION™ fieldbus (pending)	
Physical layer	FOUNDATION™ fieldbus protocol that agrees with IEC 61158-2 and FISCO model; galvanically isolated

Communication standard	H1
ITK version	6.3
Function blocks	1 × Enhanced Resource Block (RB), 1 × Customer Level Transducer Block (LEVELTB), 1 × Customer Converter Transducer Block (CONVTB), 1 × Customer Diagnosis Transducer Block (DIAGTB), 4 × Analog Input Block (AI), 1 × Digital Input (DI), 1 × Integrator Block (IT), 1 × Proportional Integral Derivate Block (PID), 1 × Arithmetic Block (AR)
	Analog Input Block: 10 ms
	Digital Input Block: 20 ms
	Integrator Block: 15 ms
	Proportional Integral Derivate Block: 25 ms
Device power supply	Not intrinsically safe: 9...32 V DC
	Intrinsically safe: 9...24 V DC
Basic current	18 mA
Maximum error current FDE	25.5 mA (= basic current + error current = 18 mA + 7.5 mA)
Polarity sensitivity	No
Minimum cycle time	250 ms
Output data	Level, distance, volume, ullage volume, mass, ullage mass
Input data	None
Link Active Scheduler	Supported
NAMUR NE 107 data	Supported with FF field diagnosis (FF-891)

Approvals and certification

CE	The device meets the essential requirements of the EU Directives. The manufacturer certifies successful testing of the product by applying the CE marking. For more data about the EU Directives and European Standards related to this device, refer to the EU Declaration of Conformity. This document is supplied with the device. You can also download this document free of charge from the website.
Vibration resistance	EN 60068-2-6 and EN 60721-3-4 (1...9 Hz: 3 mm / 10...200 Hz: 1g, 10g shock ½ sinus: 11 ms)
Explosion protection	
ATEX (EU Type Approval)	II 1/2 G Ex ia IIC T6...T3 Ga/Gb;
	II 1/2 D Ex ia IIIC T85°C...T*°C Da/Db; ③
	II 1/2 G Ex db ia IIC T6...T3 Ga/Gb;
	II 1/2 D Ex ia tb IIIC T85°C...T*°C Da/Db ③
ATEX (Type Approval)	II 3 G Ex ic IIC T6...T3 Gc;
	II 3 D Ex ic IIIC T85°C...T*°C Dc ③
IECEX	Ex ia IIC T6...T3 Ga/Gb;
	Ex ia IIIC T85°C...T*°C Da/Db; ③
	Ex db ia IIC T6...T3 Ga/Gb;
	Ex ia tb IIIC T85°C...T*°C Da/Db; ③
	Ex ic IIC T6...T3 Gc;
	Ex ic IIIC T85°C...T*°C Gc ③

cQPSus	Division ratings
	XP-IS, Class I, Div 1, GPS ABCD, T6...T3;
	DIP, Class II, III, Div 1, GPS EFG, T85°C...T*°C; ③
	IS, Class I, Div 1, GPS ABCD, T6...T3;
	IS, Class II, III, Div 1, GPS EFG, T85°C...T*°C; ③
	NI, Class I, Div 2, GPS ABCD, T6...T3;
	NI, Class II, III, Div 2, GPS FG, T85°C...T*°C ③
	Zone ratings
	Class I, Zone 1, AEx db ia [ia Ga] IIC T6...T3 Gb (US) – antenna suitable for Zone 0; Ex db ia [ia Ga] IIC T6...T3 Gb (Canada) – antenna suitable for Zone 0;
	Class I, Zone 0, AEx ia IIC T6...T3 Ga (US); Ex ia IIC T6...T3 Ga (Canada);
Zone 20, AEx ia IIIC T85°C...T*°C Da (US); Ex ia IIIC T85°C...T*°C Da (Canada); ③	
Zone 21, AEx ia tb [ia Da] IIIC T85°C...T*°C Db (US) – antenna suitable for Zone 20 Ex ia tb [ia Da] IIIC T85°C...T*°C Db (Canada) – antenna suitable for Zone 20 ③	
NEPSI - pending	Ex ia IIC T3~T6 Ga/Gb;
	Ex d ia IIC T3~T6 Ga/Gb;
	Ex iaD 20/21 T85...T* IP6X; ④
	Ex iaD 20/21 tD A21 IP6X T85°C...T*°C ③
Other standards and approvals	
Electromagnetic compatibility	EU: Electromagnetic Compatibility directive (EMC)
Radio approvals	EU: Radio Equipment directive (RED)
	FCC Rules: Part 15
	Industry Canada: RSS-211
Electrical safety	EU: Agrees with the safety part of the Low Voltage directive (LVD)
	USA and Canada: Agrees with NEC and CEC requirements for installation in ordinary locations
NAMUR	NAMUR NE 21 Electromagnetic Compatibility (EMC) of Industrial Process and Laboratory Control Equipment
	NAMUR NE 43 Standardization of the Signal Level for the Failure Information of Digital Transmitters
	NAMUR NE 53 Software and Hardware of Field Devices and Signal Processing Devices with Digital Electronics
	NAMUR NE 107 Self-Monitoring and Diagnosis of Field Devices
CRN	Pending. This certification is applicable for all Canadian provinces and territories. For more data, refer to the website.
Construction code	Option: NACE MR 0175 / MR 0103 / ISO 15156; ASME B31.3

① Kalrez® is a registered trademark of DuPont Performance Elastomers L.L.C.

② HART® is a registered trademark of the HART Communication Foundation

③ T*°C = 150°C or 200°C. For more data, refer to the related Ex approval certificate.

④ T* = 150°C or 200°C. For more data, refer to the related Ex approval certificate.

2.2 Measuring accuracy

Use these graphs to find the measuring accuracy for a given distance from the transmitter.

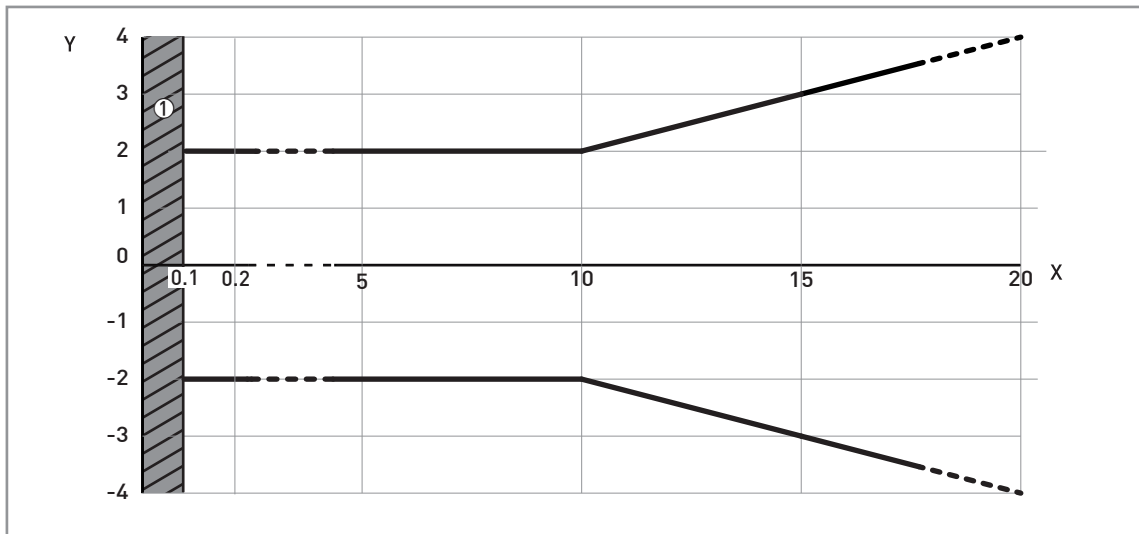

Figure 2-1: Measuring accuracy (graph of measuring accuracy in mm against measuring distance in m)

X: Measuring distance from the thread stop or flange facing of the process connection [m]

Y: Measuring accuracy [+yy mm / -yy mm]

① Minimum recommended blocking distance = antenna extension length + antenna length + 100 mm

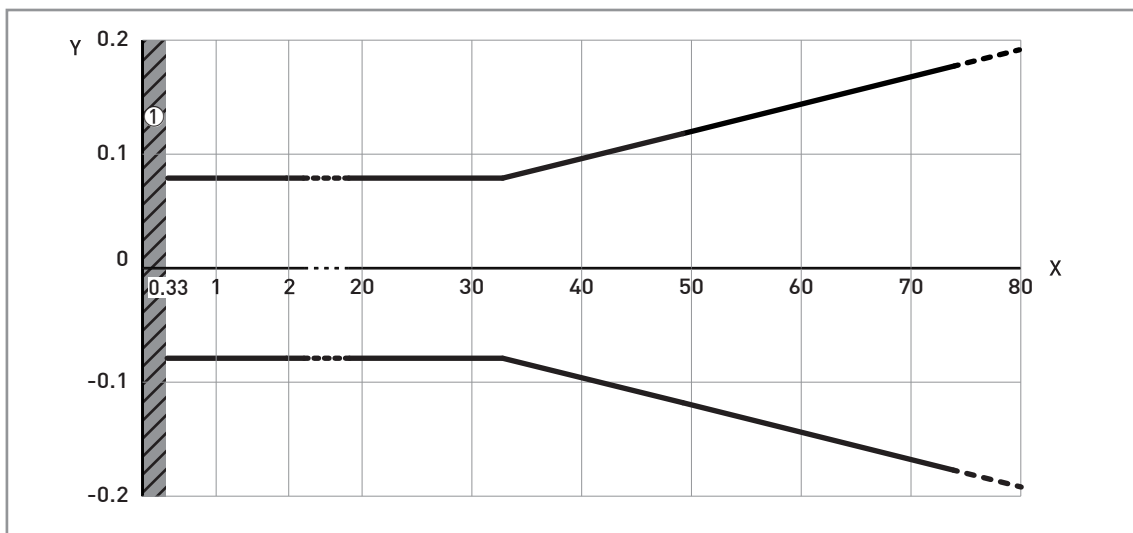

Figure 2-2: Measuring accuracy (graph of measuring accuracy in inches against measuring distance in ft)

X: Measuring distance from the thread stop or flange facing of the process connection [ft]

Y: Measuring accuracy [+yy inches / -yy inches]

① Minimum recommended blocking distance = antenna extension length + antenna length + 3.94"

To calculate the accuracy at a given distance from the antenna, refer to Technical data on page 11 (measuring accuracy).

2.3 Minimum power supply voltage

Use these graphs to find the minimum power supply voltage for a given current output load.

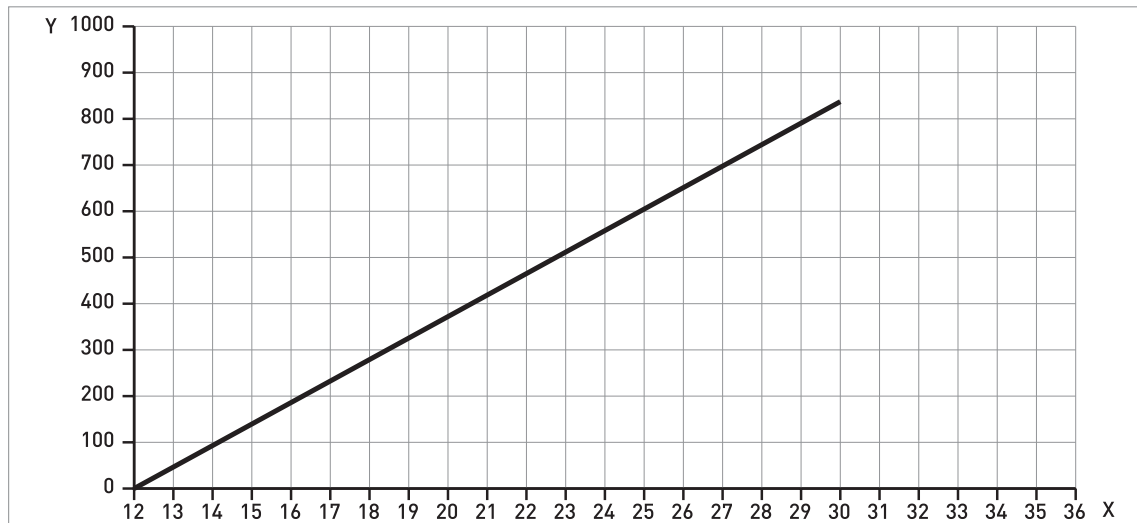

Figure 2-3: Minimum power supply voltage for an output of 21.5 mA at the terminals (Non-Ex and Hazardous Location approval (Ex i / IS))

X: Power supply U [V DC]

Y: Current output load R_L [Ω]

Hazardous Location (Ex d / XP/NI) approved devices

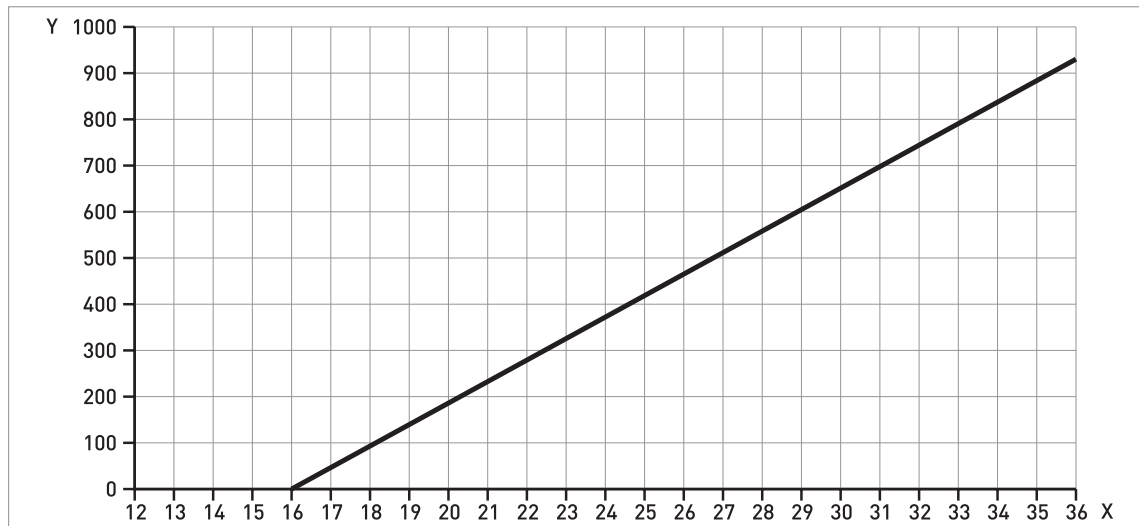

Figure 2-4: Minimum power supply voltage for an output of 21.5 mA at the terminals (Hazardous Location approval [Ex d / XP/NI])

X: Power supply U [V DC]

Y: Current output load R_L [Ω]

2.4 Guidelines for maximum operating pressure

Make sure that the devices are used within their operating limits.

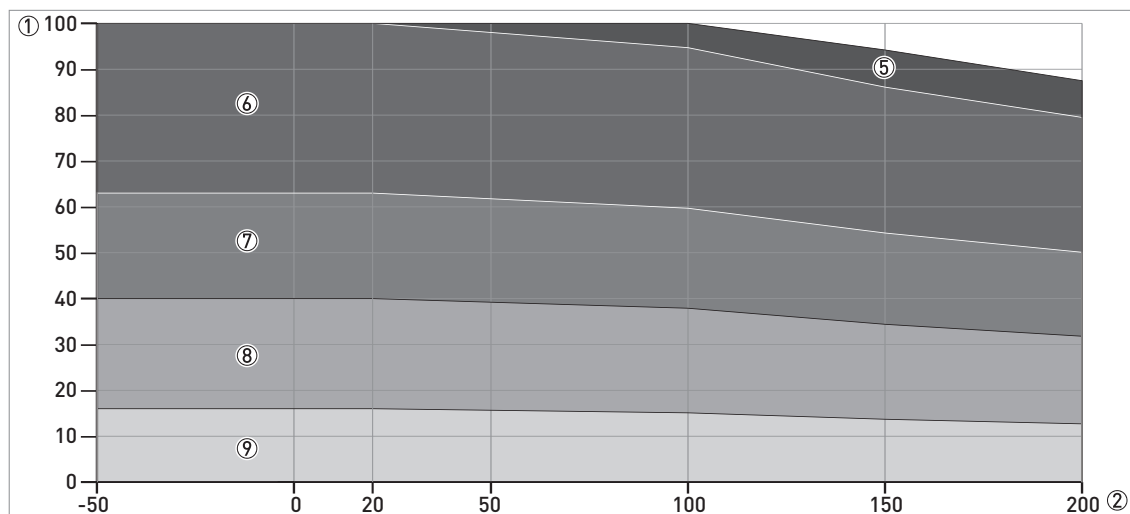

Figure 2-5: Pressure / temperature de-rating (EN 1092-1), flange and threaded connection, in °C and barg

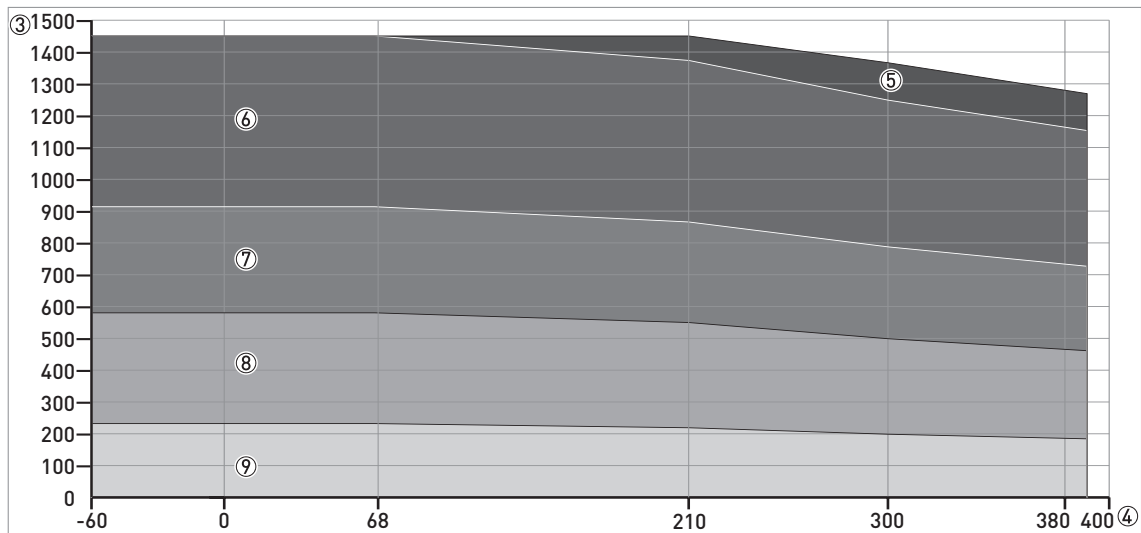

Figure 2-6: Pressure / temperature de-rating (EN 1092-1), flange and threaded connections, in °F and psig

- ① Process pressure, p [barg]
- ② Process connection temperature, T [°C]
- ③ Process pressure, p [psig]
- ④ Process connection temperature, T [°F]
- ⑤ Threaded connection, G (ISO 228-1)
- ⑥ Flange connection, PN100
- ⑦ Flange connection, PN63
- ⑧ Flange connection, PN40
- ⑨ Flange connection, PN16

CRN certification (pending)

There is a CRN certification option for devices with process connections that agree with ASME standards. This certification is necessary for all devices that are installed on a pressure vessel and used in Canada.

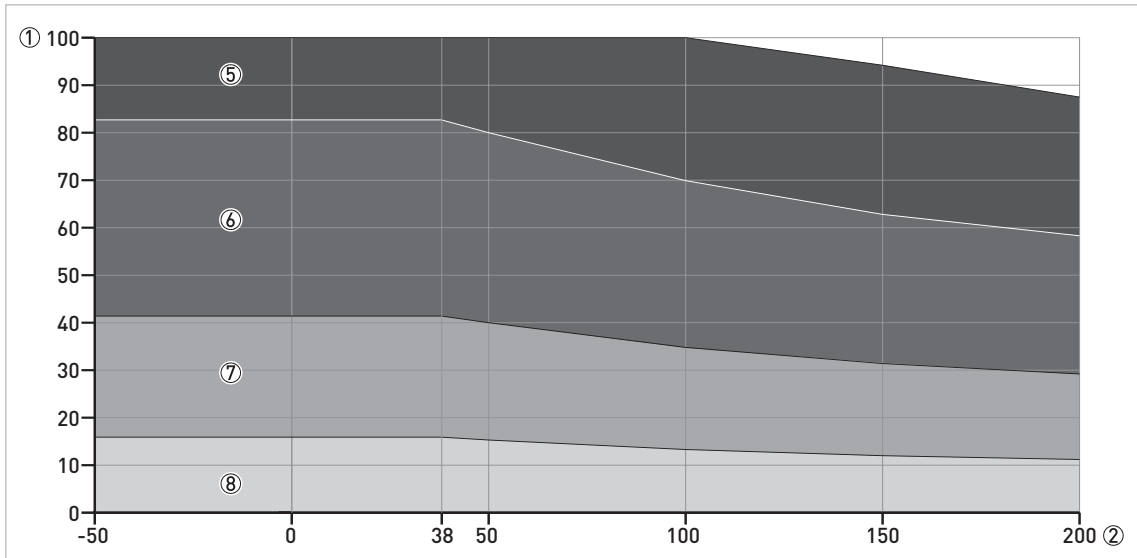

Figure 2-7: Pressure / temperature de-rating (ASME B16.5), flange and threaded connections, in °C and barg

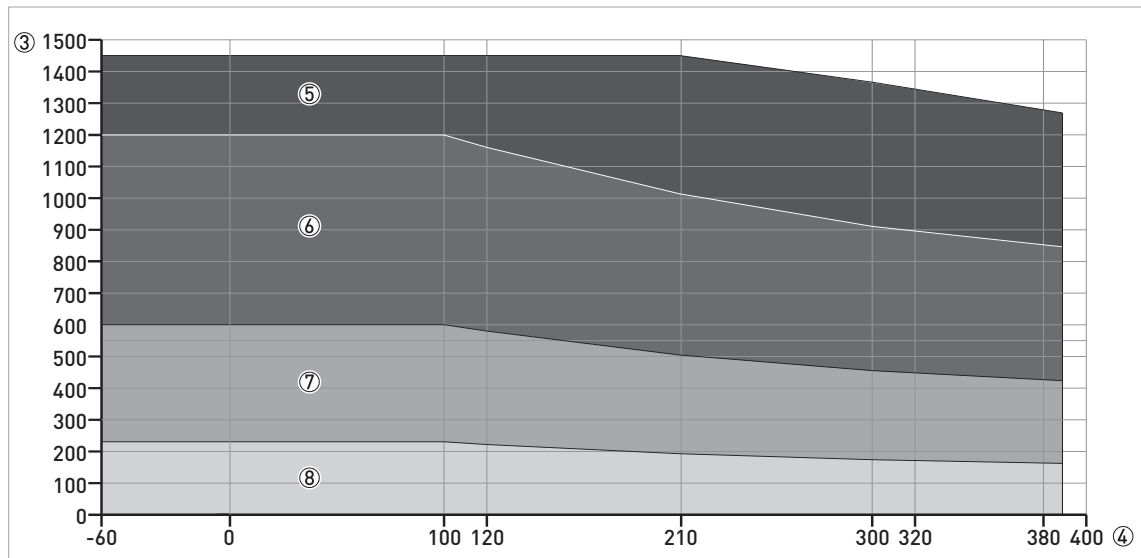

Figure 2-8: Pressure / temperature de-rating (ASME B16.5), flange and threaded connections, in °F and psig

- ① Process pressure, p [barg]
- ② Process connection temperature, T [°C]
- ③ Process pressure, p [psig]
- ④ Process connection temperature, T [°F]
- ⑤ Flange connection, Class 900 and Class 1500. Threaded connection, NPT (ASME B1.20.1).
- ⑥ Flange connection, Class 600
- ⑦ Flange connection, Class 300
- ⑧ Flange connection, Class 150

2.5 Dimensions and weights

Metallic Horn antennas with threaded connections

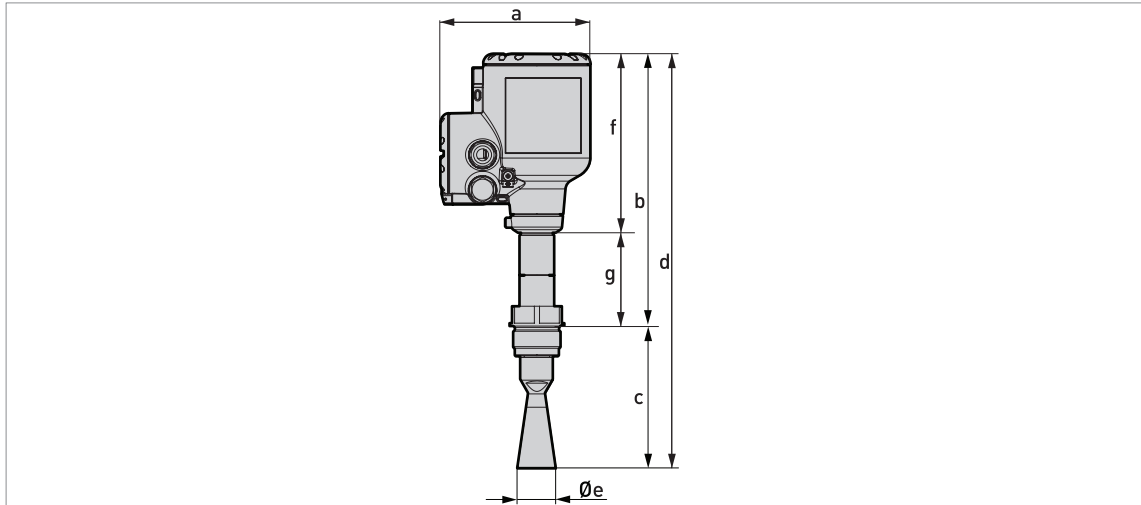

Figure 2-9: Metallic Horn antennas with G or NPT threaded connections

- *The diameter of the outer sheath of the cable must be 7...12 mm or 0.28...0.47".*
- *Cable glands for cQPSus-approved devices must be supplied by the customer.*
- *A weather protection cover is available as an accessory with all devices.*

Metallic Horn antennas with threaded connections: Dimensions in mm

Horn antenna version	Dimensions [mm]						
	a	b	c	d	Øe	f	g
DN40/1½"	151	283	143 ①	426 ①	39	179	104
DN50/2"	151	283	157 ①	440 ①	43	179	104
DN65/2½"	151	283	232	515	65	179	104
DN80/3"	151	283	267 ①	550 ①	75	179	104
DN100/4"	151	283	335 ①	618 ①	95	179	104
DN150/6"	151	283	490 ①	773 ①	140	179	104
DN200/8"	151	283	662 ①	945 ①	190	179	104

① This is the dimension without the antenna extension option. A maximum of 10 antenna extensions are available. Each antenna extension is 105 mm long.

Metallic Horn antennas with threaded connections: Dimensions in inches

Horn antenna version	Dimensions [inches]						
	a	b	c	d	Øe	f	g
DN40/1½"	5.94	11.14	5.63 ①	16.77 ①	1.54	7.05	4.09
DN50/2"	5.94	11.14	6.18 ①	17.32 ①	1.69	7.05	4.09
DN65/2½"	5.94	11.14	9.13	20.27	2.56	7.05	4.09
DN80/3"	5.94	11.14	10.51 ①	21.65 ①	2.95	7.05	4.09
DN100/4"	5.94	11.14	13.19 ①	24.33 ①	3.74	7.05	4.09
DN150/6"	5.94	11.14	19.29 ①	30.43 ①	5.51	7.05	4.09
DN200/8"	5.94	11.14	26.06 ①	37.20 ①	7.48	7.05	4.09

① This is the dimension without the antenna extension option. A maximum of 10 antenna extensions are available. Each antenna extension is 4.1" long.

Metallic Horn antenna versions with standard flange connections

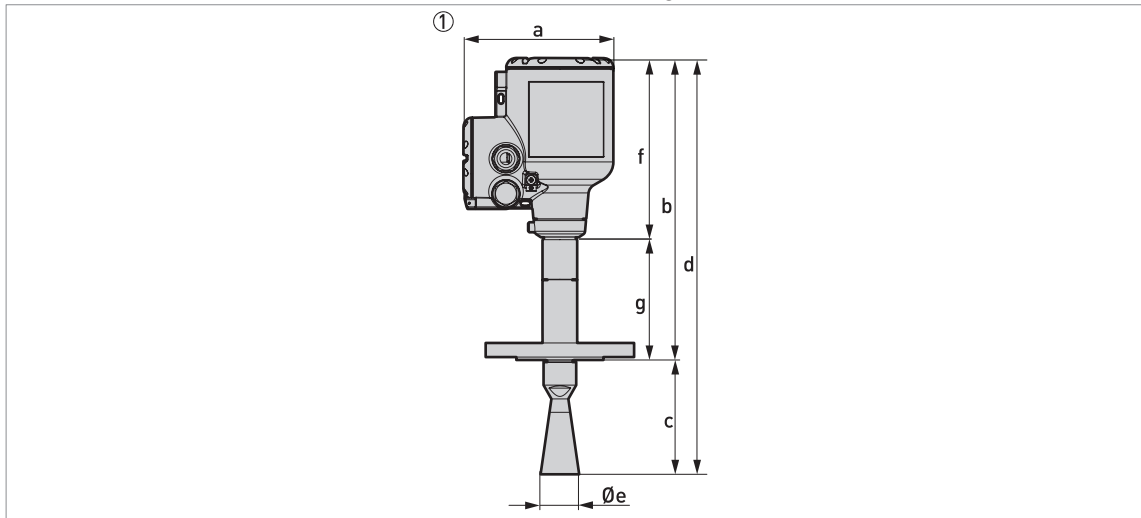

Figure 2-10: Metallic Horn antennas with standard flange connections

① Metallic Horn antenna with a flange connection

- *The diameter of the outer sheath of the cable must be 7...12 mm or 0.28...0.47".*
- *Cable glands for cQPSus-approved devices must be supplied by the customer.*
- *A weather protection cover is available as an accessory with all devices.*

Metallic Horn antennas with standard flange connections: Dimensions in mm

Horn antenna version	Dimensions [mm]						
	a	b	c	d	Øe	f	g
DN40/1½"	151	303	115 ①	418 ①	39	179	123
DN50/2"	151	303	129 ①	432 ①	43	179	123
DN65/2½"	151	303	204	507	65	179	123
DN80/3"	151	303	239 ①	542 ①	75	179	123
DN100/4"	151	303	307 ①	610 ①	95	179	123
DN150/6"	151	303	462 ①	765 ①	140	179	123
DN200/8"	151	303	634 ①	937 ①	190	179	123

① This is the dimension without the antenna extension option. A maximum of 10 antenna extensions are available. Each antenna extension is 105 mm long.

Metallic Horn antennas with standard flange connections: Dimensions in inches

Horn antenna version	Dimensions [inches]						
	a	b	c	d	Øe	f	g
DN40/1½"	5.94	11.93	4.52 ①	16.46 ①	1.54	7.05	4.84
DN50/2"	5.94	11.93	5.08 ①	17.01 ①	1.69	7.05	4.84
DN65/2½"	5.94	11.93	8.03	19.96	2.56	7.05	4.84
DN80/3"	5.94	11.93	9.41 ①	21.34 ①	2.95	7.05	4.84
DN100/4"	5.94	11.93	12.09 ①	24.02 ①	3.74	7.05	4.84
DN150/6"	5.94	11.93	18.19 ①	30.11 ①	5.51	7.05	4.84
DN200/8"	5.94	11.93	24.96 ①	36.89 ①	7.48	7.05	4.84

① This is the dimension without the antenna extension option. A maximum of 10 antenna extensions are available. Each antenna extension is 4.1" long.

Metallic Horn antenna versions with low-pressure flange connections

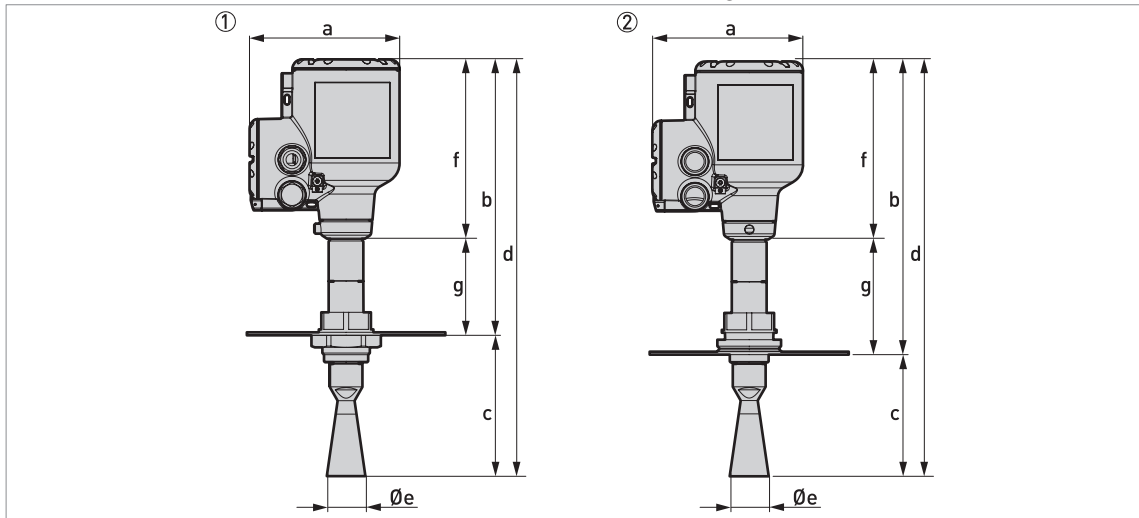

Figure 2-11: Metallic Horn antennas with low-pressure flange connections

- ① Metallic Horn antenna with a low-pressure flange attached to a G threaded connection (ISO 228-1)
- ② Metallic Horn antenna with a low-pressure flange attached to an NPT threaded connection (ASME B1.20.1)

- *The diameter of the outer sheath of the cable must be 7...12 mm or 0.28...0.47".*
- *Cable glands for cQPSus-approved devices must be supplied by the customer.*
- *A weather protection cover is available as an accessory with all devices.*

Metallic Horn antennas with low-pressure flange connections: Dimensions in mm

Horn antenna version	Dimensions [mm]									
	a	b		c	d		Øe	f	g	
		G	NPT		G	NPT			G	NPT
DN40/1½"	151	275	307	140 ①	416 ①	447	39	179	97	129
DN50/2"	151	275	307	154 ①	429 ①	461	43	178	96	128
DN65/2½"	151	275	307	229	504	536	65	178	96	128
DN80/3"	151	275	307	264 ①	539 ①	571	75	178	96	128
DN100/4"	151	275	307	332 ①	607 ①	639	95	178	96	128
DN150/6"	151	275	307	487 ①	762 ①	794	140	178	96	128
DN200/8"	151	275	307	659 ①	934 ①	966	190	178	96	128

① This is the dimension without the antenna extension option. A maximum of 10 antenna extensions are available. Each antenna extension is 105 mm long.

Metallic Horn antennas with low-pressure flange connections: Dimensions in inches

Horn antenna version	Dimensions [mm]									
	a	b		c	d		Øe	f	g	
		G	NPT		G	NPT			G	NPT
DN40/1½"	5.94	10.83	12.09	5.51 ①	16.38 ①	17.60 ①	1.53	7.05	3.82	5.08
DN50/2"	5.94	10.83	12.09	6.06 ①	16.89 ①	18.15 ①	1.69	7.05	3.78	5.04
DN65/2½"	5.94	10.83	12.09	3.02	19.84	21.10 ①	2.56	7.05	3.78	5.04
DN80/3"	5.94	10.83	12.09	10.39 ①	21.22 ①	22.48 ①	2.95	7.05	3.78	5.04
DN100/4"	5.94	10.83	12.09	13.07 ①	23.90 ①	25.16 ①	3.74	7.05	3.78	5.04
DN150/6"	5.94	10.83	12.09	19.17 ①	30.00 ①	31.26 ①	5.51	7.05	3.78	5.04
DN200/8"	5.94	10.83	12.09	25.94 ①	36.77 ①	38.03 ①	7.48	7.05	3.78	5.04

① This is the dimension without the antenna extension option. A maximum of 10 antenna extensions are available. Each antenna extension is 4.1" long.

Drop antennas with threaded connections

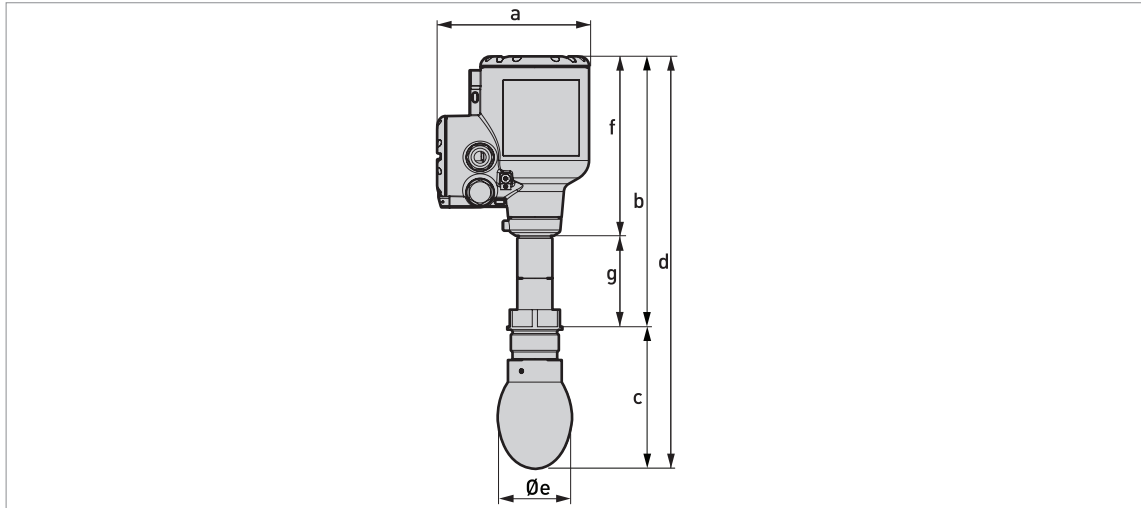

Figure 2-12: Drop antennas with threaded connections

- *The diameter of the outer sheath of the cable must be 7...12 mm or 0.28...0.47".*
- *Cable glands for cQPSus-approved devices must be supplied by the customer.*
- *A weather protection cover is available as an accessory with all devices.*

Drop antennas with threaded connections: Dimensions in mm

Drop antenna version	Dimensions [mm]						
	a	b	c	d	Øe	f	g
DN80/3" PTFE	151	283	139 ①	422 ①	74	179	104
DN80/3" PEEK	151	283	123 ①	406 ①	74	179	104
DN100/4" PTFE	151	283	163 ①	446 ①	94	179	104
DN150/6" PTFE	151	283	221 ①	504 ①	144	179	104

① This is the dimension without the antenna extension option. A maximum of 5 antenna extensions are available. Each antenna extension is 105 mm long.

Drop antennas with threaded connections: Dimensions in inches

Drop antenna version	Dimensions [inches]						
	a	b	c	d	Øe	f	g
DN80/3" PTFE	5.94	11.14	5.47 ①	16.61 ①	2.91	7.05	4.09
DN80/3" PEEK	5.94	11.14	4.84 ①	15.98 ①	2.91	7.05	4.09
DN100/4" PTFE	5.94	11.14	6.42 ①	17.56 ①	3.70	7.05	4.09
DN150/6" PTFE	5.94	11.14	8.70 ①	19.84 ①	5.67	7.05	4.09

① This is the dimension without the antenna extension option. A maximum of 5 antenna extensions are available. Each antenna extension is 4.1" long.

Drop antennas with standard flange connections

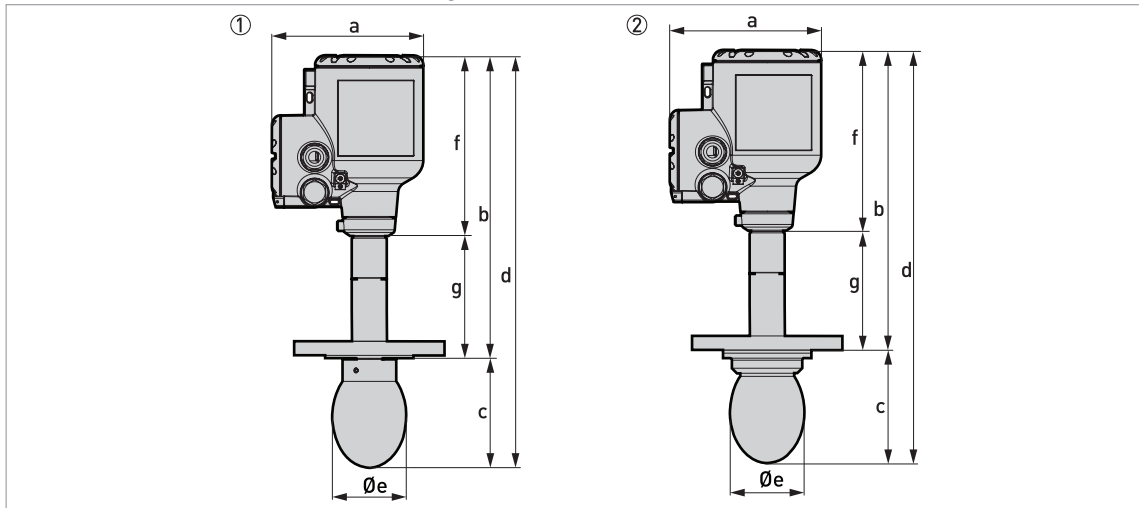

Figure 2-13: Drop antennas with standard flange connections

- ① Drop antenna with a flange connection
- ② Drop antenna with a flange connection and a flange plate protection option

- *The diameter of the outer sheath of the cable must be 7...12 mm or 0.28...0.47".*
- *Cable glands for cQPSus-approved devices must be supplied by the customer.*
- *A weather protection cover is available as an accessory with all devices.*

Drop antennas with standard flange connections: Dimensions in mm

Type of process connection	Drop antenna version	Dimensions [mm]						
		a	b	c	d	Øe	f	g
Standard flange connection	DN80/3" PTFE	151	303	111 ①	414 ①	74	179	124
	DN80/3" PEEK	151	303	95 ①	398 ①	74	179	124
	DN100/4" PTFE	151	303	135 ①	438 ①	94	179	124
	DN150/6" PTFE	151	303	193 ①	496 ①	144	179	124
Standard flange connection with flange protection	DN80/3" PTFE	151	308	106 ①	414 ①	74	179	129
	DN100/4" PTFE	151	308	130 ①	438 ①	94	179	129
	DN150/6" PTFE	151	308	188 ①	496 ①	144	179	129

① This is the dimension without the antenna extension option. A maximum of 5 antenna extensions are available. Each antenna extension is 105 mm long.

Drop antennas with standard flange connections: Dimensions in inches

Type of process connection	Drop antenna version	Dimensions [inches]						
		a	b	c	d	Øe	f	g
Standard flange connection	DN80/3" PTFE	5.94	11.93	4.37 ①	16.30 ①	2.91	7.05	4.88
	DN80/3" PEEK	5.94	11.93	3.74 ①	15.67 ①	2.91	7.05	4.88
	DN100/4" PTFE	5.94	11.93	5.31 ①	17.24 ①	3.70	7.05	4.88
	DN150/6" PTFE	5.94	11.93	7.60 ①	19.53 ①	5.67	7.05	4.88
Standard flange connection with flange protection	DN80/3" PTFE	5.94	12.13	4.17 ①	16.30 ①	2.91	7.05	5.08
	DN100/4" PTFE	5.94	12.13	5.12 ①	17.24 ①	3.70	7.05	5.08
	DN150/6" PTFE	5.94	12.13	7.40 ①	19.53 ①	5.67	7.05	5.08

① This is the dimension without the antenna extension option. A maximum of 5 antenna extensions are available. Each antenna extension is 4.1" long.

Drop antennas with low-pressure flange connections

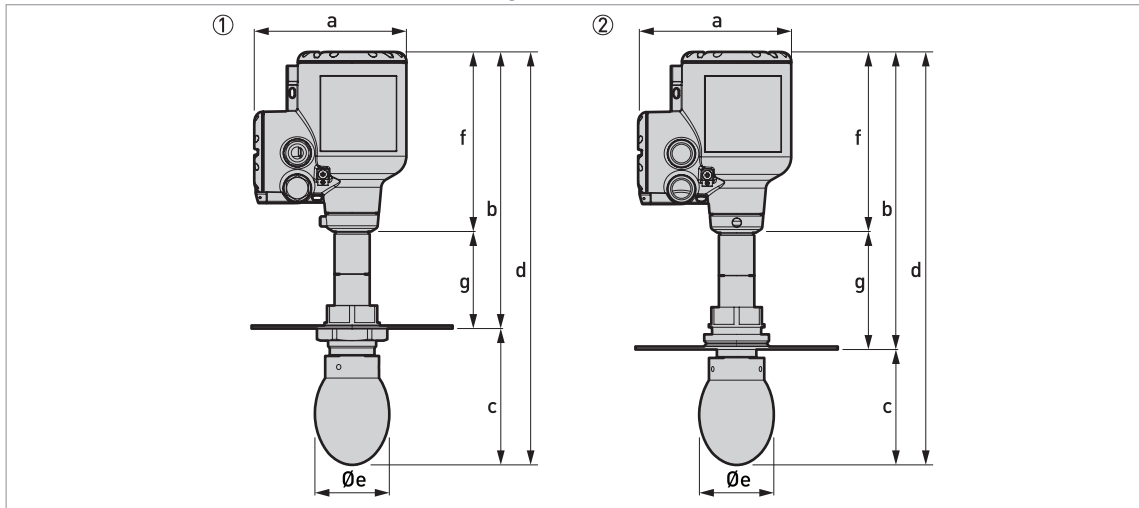

Figure 2-14: Drop antennas with low-pressure flange connections

- ① Metallic Horn antenna with a low-pressure flange attached to a G threaded connection (ISO 228-1)
- ② Metallic Horn antenna with a low-pressure flange attached to an NPT threaded connection (ASME B1.20.1)

- *The diameter of the outer sheath of the cable must be 7...12 mm or 0.28...0.47".*
- *Cable glands for cQPSus-approved devices must be supplied by the customer.*
- *A weather protection cover is available as an accessory with all devices.*

Drop antennas with low-pressure flange connections: Dimensions in mm

Drop antenna version	Dimensions [mm]									
	a	b		c	d		Øe	f	g	
		G	NPT		G	NPT			G	NPT
DN80/3"	151	275	334	135 ①	410 ①	469 ①	74	178	96	128
DN100/4"	151	275	334	158 ①	433 ①	492 ①	94	178	96	128
DN150/6"	151	275	334	217 ①	492 ①	551 ①	144	178	96	128

① This is the dimension without the antenna extension option. A maximum of 5 antenna extensions are available. Each antenna extension is 105 mm long.

Drop antennas with low-pressure flange connections: Dimensions in inches

Drop antenna version	Dimensions [mm]									
	a	b		c	d		Øe	f	g	
		G	NPT		G	NPT			G	NPT
DN80/3"	5.94	10.83	13.15	5.31 ①	16.14 ①	18.46 ①	2.91	7.01	3.78	5.04
DN100/4"	5.94	10.83	13.15	6.22 ①	17.05 ①	19.37 ①	3.70	7.01	3.78	5.04
DN150/6"	5.94	10.83	13.15	8.54 ①	19.37 ①	21.69 ①	5.67	7.01	3.78	5.04

① This is the dimension without the antenna extension option. A maximum of 5 antenna extensions are available. Each antenna extension is 4.1" long.

Purging and heating/cooling system options

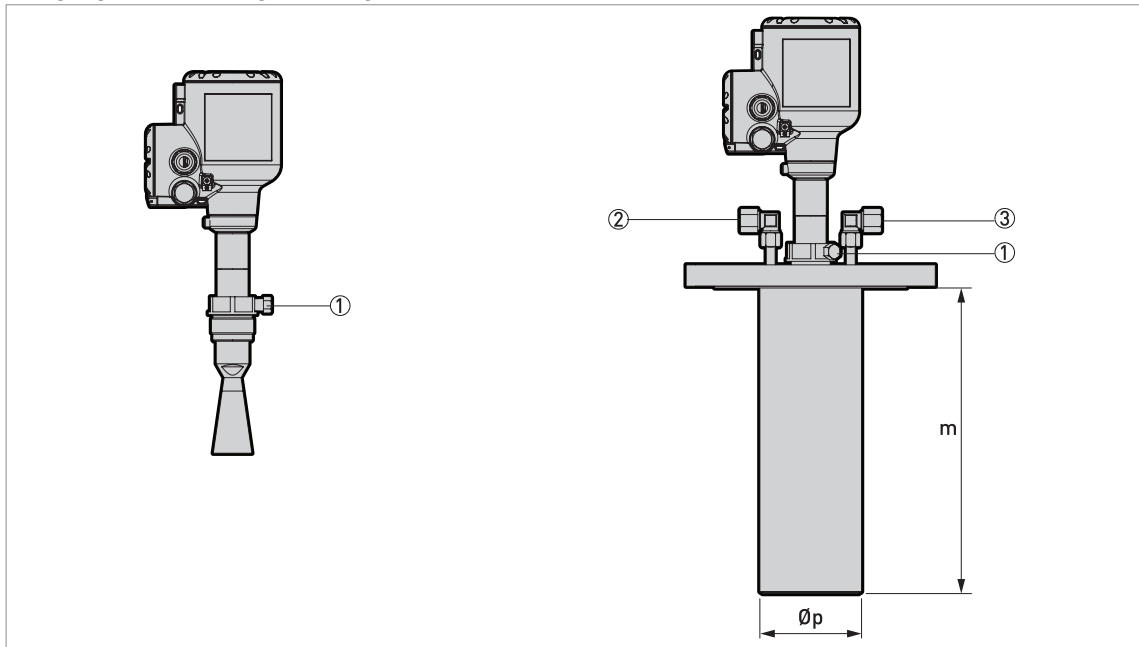

Figure 2-15: Purging and heating/cooling system options

- ① 1/8 NPTF threaded connection for purging system (the plug is supplied by the manufacturer)
- ② G 1/2 threaded connection for the heating/cooling system outlet (the plug is supplied by the manufacturer)
- ③ G 1/2 threaded connection for the heating/cooling system inlet (the plug is supplied by the manufacturer)

Heating / cooling system

This option is available for DN50, DN80 and DN100 Metallic Horn antennas with flange connections only. Flange connections must have a pressure rating of PN16 or PN40 (EN 1092-1), or Class 150 or Class 300 (ASME B16.5). The minimum flange diameter for this option is:

- DN50 Metallic Horn antenna: DN80 or 3"
- DN80 Metallic Horn antenna: DN150 or 6"
- DN100 Metallic Horn antenna: DN200 or 8"

All wetted parts (flange, antenna and heating/cooling jacket) of the heating/cooling system option are made of 316L / 1.4404.

Purging system

This option is available for all Metallic Horn antennas. Flange connections must have a pressure rating of PN16 (EN 1092-1), PN40 (EN 1092-1), Class 150 (ASME B16.5), Class 300 (ASME B16.5), or must be a low-pressure flange (PN01 / 15 psig).

Purging system and heating/cooling system: Dimensions

	Dimensions					
	DN50 / 2"		DN80 / 3"		DN100 / 4"	
	[mm]	[inch]	[mm]	[inch]	[mm]	[inch]
m	157	6.18	267	10.51	336	13.23
Øp	76	2.99	114	4.49	141	5.55

Weather protection option

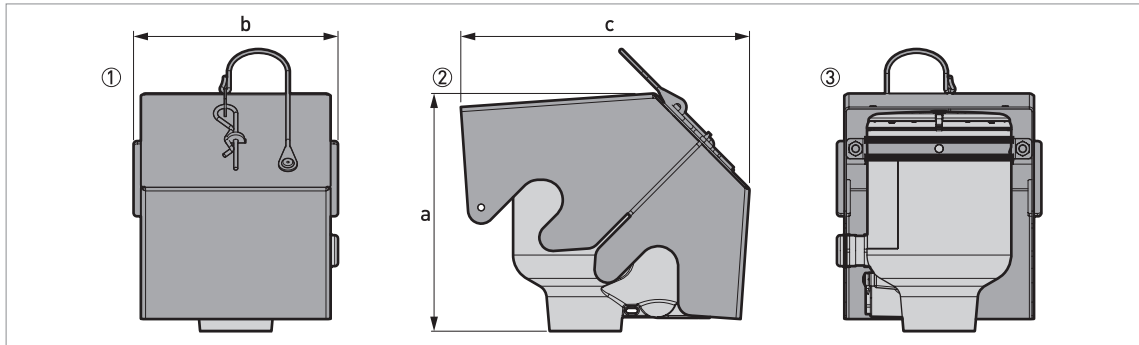

Figure 2-16: Weather protection option

- ① Front view (with weather protection closed)
- ② Left side (with weather protection closed)
- ③ Rear view (with weather protection closed)

Weather protection: Dimensions and weights

	Dimensions						Weights [kg]	
	a		b		c		[kg]	[lb]
	[mm]	[inch]	[mm]	[inch]	[mm]	[inch]		
Weather protection	177	6.97	153	6.02	216	8.50	1.3	2.9

Converter weight

Type of housing	Weights	
	[kg]	[lb]
Compact aluminium housing	3.0	6.6
Compact stainless steel housing	5.4	11.9

Antenna option weights

Antenna options	Min./Max. weights	
	[kg]	[lb]

Standard options, without converter

DN40 / 1.5" Metallic Horn antenna with process connection, standard length ①	2.3...58.7	5...129.1
DN50 / 2" Metallic Horn antenna with process connection, standard length ①	2.3...58.7	5...129.1
DN65 / 2.5" Metallic Horn antenna with process connection, standard length ①	2.5...58.9	5.5...129.6
DN80 / 3" Metallic Horn antenna with process connection, standard length ①	2.5...58.9	5.5...129.6
DN100 / 4" Metallic Horn antenna with process connection, standard length ①	2.6...59	5.7...129.8
DN150 / 6" Metallic Horn antenna with process connection, standard length ①	3...59.4	6.6...130.7
DN200 / 8" Metallic Horn antenna with process connection, standard length ①	3.7...60	8.1...132
DN80 / 3" PTFE Drop antenna with process connection, standard length ①	3.1...59.2	6.8...130.9
DN100 / 4" PTFE Drop antenna with process connection, standard length ①	3.8...60.2	8.4...132.7
DN150 / 6" PTFE Drop antenna with process connection, standard length ①	7.2...63.6	15.8...139.9
DN80 / 3" PEEK Drop antenna with process connection, standard length ①	2.8...59.2	6.2...130.2

Antenna extension options

Straight extension, length 105 mm / 4.13" ②	+0.92	+2.03
Straight extension, length 210 mm / 8.27" ②	+1.84	+4.06
Straight extension, length 315 mm / 12.40" ②	+2.76	+6.08
Straight extension, length 420 mm / 16.54" ②	+3.68	+8.11
Straight extension, length 525 mm / 20.67" ②	+4.60	+10.14
Straight extension, length 630 mm / 24.80" ③	+5.52	+12.17
Straight extension, length 735 mm / 28.94" ③	+6.44	+14.20
Straight extension, length 840 mm / 33.07" ③	+7.36	+16.23
Straight extension, length 945 mm / 37.20" ③	+8.28	+18.25
Straight extension, length 1050 mm / 41.34" ③	+9.20	+20.28

Other options

Flange plate option, DN80 / 3" PTFE Drop antenna	+0.3	+0.66
Flange plate option, DN100 / 4" PTFE Drop antenna	+0.5	+1.10
Flange plate option, DN150 / 6" PTFE Drop antenna	+0.7	+1.54
Flange plate option, DN80 / 3" PEEK Drop antenna	+0.2	+0.44

① Standard length = without antenna extensions

② This option is for Metallic Horn and Drop antennas

③ This option is for Metallic Horn antennas

3.1 Order code

Make a selection from each column to get the full order code.

LR74	4	F	LR74 Free Space Radar- 24 GHz radar (FMCW) level transmitter for agitated and corrosive liquids (up to 100 barg (1450 psig) and 200°C (392°F))
			Regional directives
		1	Europe
		2	China
		3	USA
		4	Canada
		5	Brazil
		6	Australia
		A	Russia
		B	Kazakhstan
		C	Belarus
		W	Worldwide
			Ex approvals
		0	Without
		1	ATEX II 1/2 G Ex ia IIC T6...T3 Ga/Gb + II 1/2 D Ex ia IIIC T85°C...T150°C or T85°C...T200°C Da/Db
		2	ATEX II 1/2 G Ex db ia IIC T6...T3 Ga/Gb + II 1/2 D Ex ia tb IIIC T85°C...T150°C or T85°C...T200°C Da/Db
		3	ATEX II 3 G Ex ic IIC T6...T3 Gc + II 3 D Ex ic IIIC T85°C...T150°C or T85°C...T200°C Dc
		5	NEPSI Ex ia IIC T3~T6 Ga/Gb + Ex iaD 20/21 T85...T150 or T85...T200 ①
		6	NEPSI Ex d ia IIC T3~T6 Ga/Gb + Ex iaD 20/21 tD A21 IP6X T85°C...T150°C or T85°C...T200°C ①
		A	cQPSus IS CL I/II/III DIV 1 GP A-G + CL I Z0 AEx ia/Ex ia IIC T6...T3 Ga + Z20 AEx ia/Ex ia IIIC T85°C...T150°C or T85°C...T200°C Da
		B	cQPSus XP-IS/DIP CL I DIV 1 GP A-G + CL I Z1 AEx db ia/Ex db ia IIC T6...T3 Gb + Z21 AEx ia tb/Ex ia tb IIIC T85°C...T150°C or T85°C...T200°C Db ②
		C	cQPSus NI CL I/II/III DIV 2 GP ABCDFG
		K	IECEX Ex ia IIC T6...T3 Ga/Gb + Ex ia IIIC T85°C...T150°C or T85°C...T200°C Da/Db
		L	IECEX Ex db ia IIC T6...T3 Ga/Gb + Ex ia tb IIIC T85°C...T150°C or T85°C...T200°C Da/Db
		M	IECEX Ex ic IIC T6...T3 Gc + Ex ic IIIC T85°C...T150°C or T85°C...T200°C Dc
		0	Construction
		0	Without
		2	CRN / ASME B31.3 ①
		3	NACE design (MR0175 / MR0103 / ISO 15156)
		4	ASME B31.3
		A	CRN / ASME B31.3 + NACE (MR0175 / MR0103 / ISO 15156) ①
		B	NACE (MR0175 / MR0103 / ISO 15156) + ASME B31.3
LR74	4	F	Order code (complete this code on the pages that follow)

								0	Process conditions (Pressure, temperature, material and remarks) / Process seal
									0 Without
									1 -1...40 barg (-14.5...580 psig) / -40°C...+200°C (-40°F...+392°F) / FKM/FPM
									2 -1...40 barg (-14.5...580 psig) / -50°C...+150°C (-58°F...+302°F) / EPDM
									3 -1...40 barg (-14.5...580 psig) / -20°C...+200°C (-4°F...+392°F) / Kalrez® 6375
									5 -1...40 barg (-14.5...580 psig) / -30°C...+200°C (-22°F...+392°F) / FKM/FPM ④
									6 -1...40 barg (-14.5...580 psig) / -30°C...+150°C (-22°F...+302°F) / EPDM ④
									7 -1...40 barg (-14.5...580 psig) / -20°C...+200°C (-4°F...+392°F) / Kalrez® 6375 ④
									A -1...100 barg (-14.5...1450 psig) / -40°C...+200°C (-40°F...+392°F) / FKM/FPM ⑤
									B -1...100 barg (-14.5...1450 psig) / -50°C...+150°C (-58°F...+302°F) / EPDM ⑤
									C -1...100 barg (-14.5...1450 psig) / -20°C...+200°C (-4°F...+392°F) / Kalrez® 6375 ⑤
									E -1...100 barg (-14.5...1450 psig) / -30°C...+200°C (-22°F...+392°F) / FKM/FPM ⑥
									F -1...100 barg (-14.5...1450 psig) / -30°C...+150°C (-22°F...+302°F) / EPDM ⑥
									G -1...100 barg (-14.5...1450 psig) / -20°C...+200°C (-4°F...+392°F) / Kalrez® 6375 ⑥
									Antennas (antenna type, material, radio approval)
									0 Without
									1 Metallic Horn, DN40 (1.5") / 316L / TLPR ⑦
									2 Metallic Horn, D50 (2") / 316L / TLPR ⑦
									3 Metallic Horn, DN65 (2.5") for BM26 A / 316L / TLPR ⑦
									4 Metallic Horn, DN80 (3") / 316L / LPR ⑦
									5 Metallic Horn, DN100 (4") / 316L / LPR ⑦
									6 Metallic Horn, DN150 (6") / 316L / LPR ⑦
									7 Metallic Horn, DN200 (8") / 316L / LPR ⑦
									E Drop, DN80 (3") / max. +150°C (+302°F) / PTFE / LPR ⑦
									F Drop, DN100 (4") / max. +150°C (+302°F) / PTFE / LPR ⑦
									G Drop, DN150 (6") / max. +150°C (+302°F) / PTFE / LPR ⑦
									K Drop, DN80 (3") / max. +200°C (+392°F) / PEEK / LPR ⑦
									Antenna extension / Flange plate protection
									0 Without
LR74	4	F						0	Order code (complete this code on the pages that follow)

													Extension			
													1	105 mm (4") / 316L		
													2	210 mm (8") / 316L		
													3	315 mm (12") / 316L		
													4	420 mm (17") / 316L		
													5	525 mm (21") / 316L		
													6	630 mm (24") / 316L for Metallic Horn antennas		
													7	735 mm (29") / 316L for Metallic Horn antennas		
													8	840 mm (33") / 316L for Metallic Horn antennas		
													A	945 mm (37") / 316L for Metallic Horn antennas		
	B	1050 mm (41") / 316L for Metallic Horn antennas														
													Flange plate protection			
													D	Without / with flange plate protection		
													Extension with flange and extension protection			
													M	105 mm (4") for PTFE Drop antenna / PTFE		
													N	210 mm (8") for PTFE Drop antenna / PTFE		
													P	315 mm (12") for PTFE Drop antenna / PTFE		
													Process connection: Size / Pressure class / Flange face finish			
													ISO 228 (threaded connection)			
													G	P	0	G 1 1/2 A
													ASME B1.20.1 (threaded connection)			
													G	A	0	1 1/2 NPT
													Low-pressure flange (screwed to G 1½A connection)			
													H	C	7	DN50 PN01
													L	C	7	DN80 PN01
													M	C	7	DN100 PN01
													P	C	7	DN150 PN01
													R	C	7	DN200 PN01
													Low-pressure flange (screwed to 1½ NPT connection)			
													H	1	B	2" 150 lb, 15 psig max.
													L	1	B	3" 150 lb, 15 psig max.
													M	1	B	4" 150 lb, 15 psig max.
													P	1	B	6" 150 lb, 15 psig max.
													R	1	B	8" 150 lb, 15 psig max.
LR74	4	F				0									Order code (complete this code on the pages that follow)	

																			EN 1092-1 flange
																			G G 1 DN40 PN40 – Type B1
																			G H 1 DN40 PN63 – Type B1
																			G K 1 DN40 PN100 – Type B1
																			H E 1 DN50 PN16 – Type B1
																			H G 1 DN50 PN40 – Type B1
																			H H 1 DN50 PN63 – Type B1
																			H K 1 DN50 PN100 – Type B1
																			L E 1 DN80 PN16 – Type B1
																			L G 1 DN80 PN40 – Type B1
																			L H 1 DN80 PN63 – Type B1
																			L K 1 DN80 PN100 – Type B1
																			M E 1 DN100 PN16 – Type B1
																			M G 1 DN100 PN40 – Type B1
																			M H 1 DN100 PN63 – Type B1
																			M K 1 DN100 PN100 – Type B1
																			P E 1 DN150 PN16 – Type B1
																			P G 1 DN150 PN40 – Type B1
																			P H 1 DN150 PN63 – Type B1
																			P K 1 DN150 PN100 – Type B1
																			R E 1 DN200 PN16 – Type B1
																			R G 1 DN200 PN40 – Type B1
LR74	4	F		0															Order code (complete this code on the pages that follow)

											ASME B16.5 flange											
											G	1	A	1½" 150 lb RF								
											G	2	A	1½" 300 lb RF								
											G	3	A	1½" 600 lb RF								
											G	4	M	1½" 900 lb RJ								
											G	5	M	1½" 1500 lb RJ								
											H	1	A	2" 150 lb RF								
											H	2	A	2" 300 lb RF								
											H	3	A	2" 600 lb RF								
											H	4	M	2" 900 lb RJ								
											H	5	M	2" 1500 lb RJ								
											L	1	A	3" 150 lb RF								
											L	2	A	3" 300 lb RF								
											L	3	A	3" 600 lb RF								
											L	4	A	3" 900 lb RF								
											M	1	A	4" 150 lb RF								
											M	2	A	4" 300 lb RF								
											M	3	A	4" 600 lb RF								
											M	4	A	4" 900 lb RF								
											P	1	A	6" 150 lb RF								
											P	2	A	6" 300 lb RF								
											R	1	A	8" 150 lb RF								
											R	2	A	8" 300 lb RF								
																						JIS B2220 flange
																						G
H	U	P	50A JIS 10K RF																			
L	U	P	80A JIS 10K RF																			
M	U	P	100A JIS 10K RF																			
P	U	P	150A JIS 10K RF																			
R	U	P	200A JIS 10K RF																			
											Alternative flange facing (avail. by special request)											
														EN 1092-1 flange								
											2			Type B2 (surface roughness must be specified in the order)								
											3			Type C (Tongue)								
											4			Type D (Groove)								
											5			Type E (Spigot)								
											6			Type F (Recess)								
											7			Type A (Flat Face)								
LR74	4	F		0			0					Order code (complete this code on the pages that follow)										

																			ASME B16.5 flange
																			B FF (Flat Face)
																			M RJ (Ring Joint)
																			Calibration certificate
																			0 Without: Accuracy ±2 mm (±0.08")
																			1 Calibration certificate ±2 mm (±0.08") up to 10 m (32.81 ft), 2 points
																			2 Calibration certificate ±2 mm (±0.08") up to 10 m (32.81 ft), 5 points
																			3 Calibration certificate ±2 mm (±0.08") up to 10 m (32.81 ft), 5 points specified by the customer min. ≥ 400 mm (16")
																			Options
																			0 Without
																			1 Heating / Cooling system with G 1/2 connections ⑧
																			2 Purging system with 1/8 NPTF connection ⑨
																			3 Heating / Cooling + purging systems ⑧
																			Accessories / Tag plate
																			0 Without
																			1 Weather protection
																			3 Stainless steel Tag plate (18 characters max.)
																			6 Weather protection + Stainless steel Tag plate (18 characters max.)
LR74	4	F	0									0							Order code

- ① Pending
- ② DIP = Dust Ignition Proof.
- ③ This housing option has Ex ia and Ex ic approvals. The Ex d approval for this option is pending.
- ④ METAGLAS® dual process seal for Metallic Horn and Drop antennas
- ⑤ For Metallic Horn antennas
- ⑥ METAGLAS® dual process seal for Metallic Horn antennas
- ⑦ LPR = You can install the antenna in a closed tank or outdoors (but the antenna must point down and not be near sensitive installations (e.g. a radio astronomy station)). TLPR = You must install the antenna in a closed tank.
- ⑧ Only for Metallic Horn antennas. Heating / Cooling system: ≥DN80 (≥3") flange for DN50 (2") Horn antenna, ≥DN150 (≥6") flange for DN80 (3") Horn antenna or ≥DN200 (≥8") flange for DN100 (4") Horn antenna
- ⑨ Only for Metallic Horn antennas

ADDITIONAL PRODUCTS

These product lines offer a broad range of measurement and instrument products, including solutions for pressure, flow, analytical, temperature, positioning, controlling and recording.

For a list of these offerings, visit our website at:
www.schneider-electric.com

Schneider Electric Systems USA, Inc. Global Customer Support
38 Neponset Avenue Inside U.S.: 1-866-746-6477
Foxboro, MA 02035 Outside U.S.: 1-508-549-2424
United States of America <https://pasupport.schneider-electric.com>
<http://www.schneider-electric.com>

Copyright 2019 Schneider Electric Systems USA, Inc.
All rights reserved.

Foxboro and Schneider Electric are trademarks of Schneider Electric Systems USA, Inc., its subsidiaries, and affiliates. All other trademarks are the property of their respective owners.

