

SRP981 Pneumatic Positioner



The SRP981 Positioner is for operation of pneumatic valve actuators with pneumatic control signals. It is used to reduce the adverse effects of valve friction, for higher thrust and shorter positioning time.

FEATURES

- Independent adjustment of stroke range and zero
- Adjustable amplification and damping
- Split range up to 4-fold possible
- Supply pressure up to 6 bar (90 psig)
- Low vibration effect in all directions
- Mounting according to IEC 534, part 6 (NAMUR)
- Rotation adapter for angles up to 120°
- Certificate No. 90/20226(E2) Lloyd's Register of Shipping for use on vessels
- Modular system of additional equipment
 - Electrical limit switches
 - Electrical position transmitter
 - Booster
 - Connection manifold

CONTENTS

| CHP. | CONTENTS | PAGE |
|----------|---|-----------|
| 1 | GENERAL | 3 |
| 1.1 | Identification | 3 |
| 1.2 | Method of operation. | 4 |
| 1.3 | Additional equipment. | 5 |
| 2 | MOUNTING | 6 |
| 2.1 | Dimensions | 6 |
| 2.1.1 | Positioner. | 6 |
| 2.1.2 | Options | 6 |
| | Built-in limit switch, Model Code R, T, U, V | |
| | Position transmitter, Model Code W | |
| 2.1.3 | Additional parts | 7 |
| | Booster relays, Connection manifolds, | |
| | Connection manifolds with gauges | |
| 2.2 | Attachment to diaphragm actuators | |
| | according to IEC 534-6 (NAMUR) | 8 |
| 2.2.1 | Dimensions | 8 |
| 2.2.2 | Determining the mounting side | 9 |
| 2.2.3 | Attachment to diaphragm actuators. | 9 |
| 2.3 | Attachment kit for rotary actuators. | 10 |
| 2.3.1 | Dimensions | 10 |
| 2.3.2 | Attachment to rotary actuators | 11 |
| 2.3.3 | Reversing the direction of rotation. | 12 |
| 3 | ELECTRICAL CONNECTIONS (of options) . | 13 |
| 3.1 | Limit switches | 13 |
| 3.2 | Position transmitter 4-20 mA | 13 |
| 3.2.1 | Direct power supply | 13 |
| 3.2.2 | Supply with Power Supply Unit | 13 |
| 4 | COMMISSIONING | 14 |
| 4.1 | Setting the amplification | 14 |
| 4.2 | Setting of zero and stroke | 14 |
| 4.3 | Setting the damping. | 15 |
| 4.4 | Subdivision of the input range (split range) | 15 |
| 4.5 | Determining of the rotation angle factor U_{ϕ} | 15 |
| 4.6 | Determination of the stroke factor U_x | 16 |
| 4.6.1 | Stroke factor ranges of the range springs | 16 |
| 4.6.2 | Characteristics of the range springs | 17 |
| 4.7 | Manual bypass switch | 17 |
| 5 | MAINTENANCE | 18 |
| 5.1 | Basic adjustment of the | |
| | single acting positioner | 18 |
| 5.2 | Basic adjustment of the | |
| | double acting positioner. | 19 |
| 5.3 | Cleaning the throttle | 20 |
| 6 | REPLACING SUBASSEMBLIES | 20 |
| 6.1 | Replacing the amplifier | 20 |
| 6.2 | Replacing the amplifier diaphragm | |
| | in the single acting positioner | 21 |
| 6.3 | Replacing the amplifier diaphragm | |
| | in the double acting positioner. | 22 |

| CHP. | CONTENTS | PAGE |
|-----------|--|-----------|
| 7 | Option "Built-in limit switch" | 23 |
| 7.1 | Method of operation. | 23 |
| 7.2 | Electrical connections | 23 |
| 7.3 | Arrangement of connection | 23 |
| 7.4 | Commissioning | 23 |
| 7.5 | Adjusting the switching points | 24 |
| 7.6 | Maintenance | 24 |
| 7.7 | Safety requirements | 24 |
| 7.8 | Subsequent installation or exchange. | 25 |
| 8 | Option "El. Position transmitter" | 26 |
| 8.1. | Method of operation. | 26 |
| 8.2 | Electrical connections | 26 |
| 8.3 | Arrangement of connection | 26 |
| 8.4 | Maintenance | 26 |
| 8.5 | Adjusting the measuring range | 27 |
| 8.6 | Conversion from normal direction of action | |
| | in reverse direction of action | 27 |
| 8.7 | Subsequent installation or exchange. | 28 |
| 9 | SAFETY REQUIREMENTS | 29 |
| 9.1 | Accident prevention | 29 |
| 9.2 | Electrical safety | 29 |
| 9.2.1 | General requirements | 29 |
| 9.2.2 | Connection requirements | 29 |
| 9.2.3 | Explosion protection | 29 |
| 9.2.4 | EMV and CE | 29 |
| 10 | TROUBLE SHOOTING | 30 |



1 GENERAL

The pneumatic positioner is used for the actuation of pneumatic actuators by means of pneumatic controllers with a continuous output of 0.2 - 1 bar or 3 - 15 psi or split ranges.

The positioner and actuator form a control loop with the command variable w_s (output signal y of the master controller), the correcting variable y_s and the linear position x_s of the actuator.

In this manner disturbances such as gland friction and medium forces are compensated.

In addition the positioning force of the actuator is increased by means of an output pressure of max. 6 bar.

The pneumatic positioner can be mounted on both diaphragm actuators and rotary actuators.

For actuators with spring resetting a single acting positioner is used, for actuators without spring resetting a double acting positioner is used.

The double acting positioner operates with two opposing control pressures.

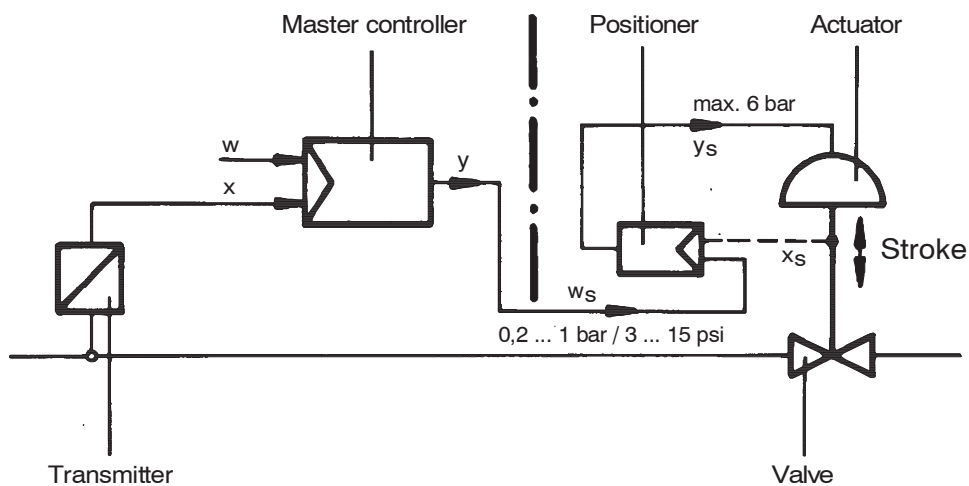

Fig. 1: Control circuit with single acting positioner

1.1 Identification

Nameplate

Example:

Single acting positioner

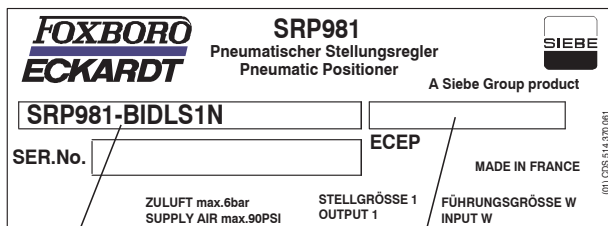

Instr. specification, Model Code

No. for customized version

Example:

Double acting positioner

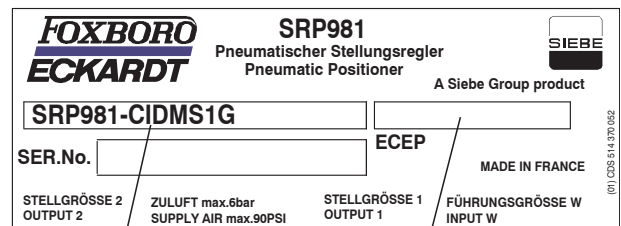

Instr. specification, Model Code

No. for customized version

1.2 Method of operation

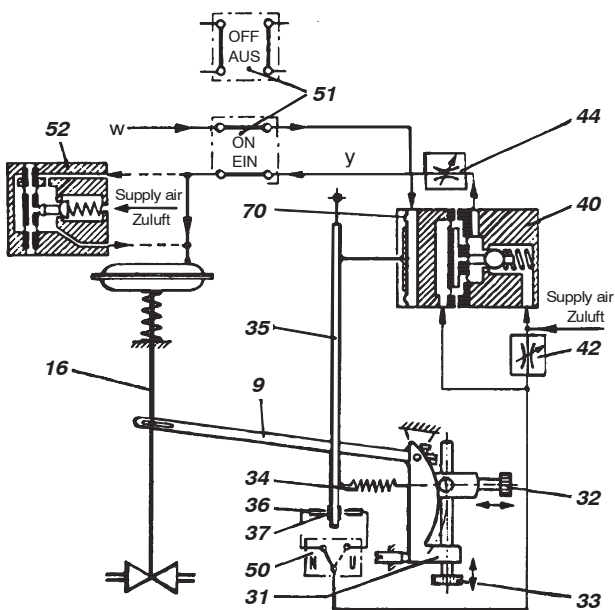

Fig. 4: Single acting positioner with additional booster 52

The positioner functions in accordance with the force balance principle:

The input signal w (0.2 ... 1 bar) acts on the input diaphragm 70¹⁾. The stroke of the input diaphragm is transferred to the flapper lever 35. The resulting axial variation of the nozzle 36 and the flapper 37 varies the dynamic pressure at the nozzle. In the single acting positioner, this pressure acts on an amplifier 40, the output pressure y of which causes a linear movement in a diaphragm actuator without spring resetting²⁾.

In the case of the double acting positioner this pressure acts on a dual amplifier 41, the opposed output pressures y_1 and y_2 of which cause a linear movement in a diaphragm actuator without spring resetting. This linear movement is picked up from the actuator spindle 16 by means of the feedback lever 9 of the positioner and transferred to the stroke factor lever 31.

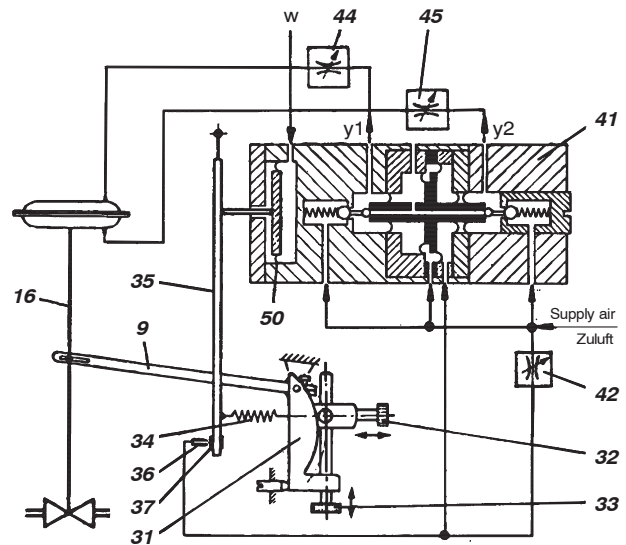

Fig. 5: Double acting positioner

The stroke factor lever 31 is connected to the flapper lever 35 by means of a range spring 34.

A force balance is created on the flapper lever 35 when the torque generated at the input diaphragm 70 coincides with the countertorque produced on the range spring 34 by the linear position. This ensures that the actuating position is always proportional to the input signal.

Dynamic matching of the actuator (sensitivity, stability) is possible by means of the throttling screw 42 and the damping throttles 44, or 44 and 45 in the case of the double acting positioner. The stroke range and zero are set by means of the zero screw 32 and the stroke factor screw 33.

The changeover plate 50 is used in the case of the single acting positioner to set either an increasing or decreasing control pressure for an increasing input signal.

- 1) If the single acting positioner is fitted with a bypass switch 51, and if this switch is set to the "OFF" position, the input signal w is supplied direct to the actuator, in other words the positioner has no effect.
- 2) A booster 52 can be installed in order to increase the air output capacity and reduce the positioning time.

1.3 Additional equipment

Single acting pneumatic positioners can be supplied with two built-in gauges for displaying the command variable **10** (input) and correcting variable **11** (output).

The air output capacity can be significantly increased by means of additional single acting and double acting boosters **52**; the positioning time is thereby shortened to between one quarter and one seventh.

A bypass switch **51** can only be installed with single acting positioners.

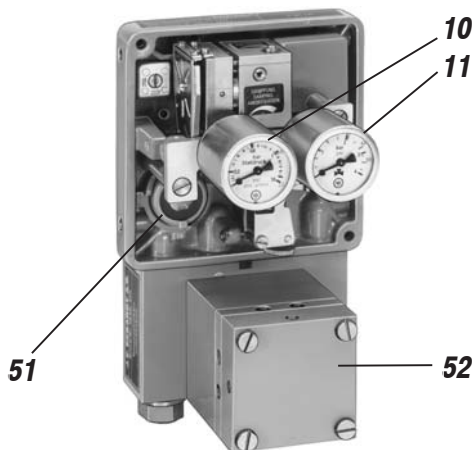

Fig. 6: Single acting pneumatic positioner with built-in gauges and booster

If 1/4-18NPT connections are desired, the connection manifolds Model Code LEXG-BN resp. -CN must be used. The connection manifold Model Code LEXG-CN is required for 10 mm piping. The connection manifold Model Code LEXG-BN is required for piping up to 12 mm.

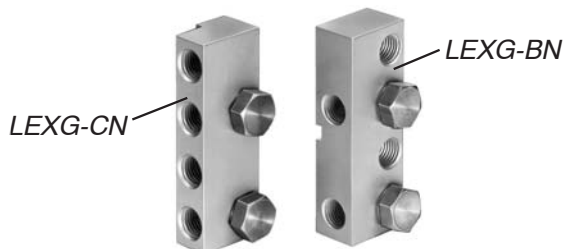

Fig. 7: Connection manifolds

If a display of the control pressure, input signal or supply air pressure is desired for single acting and double acting positioners, the connection manifold **53** with gauges (Model Code LEXG-JN, -KN, -LN, -MN or -NN) can be used.



Fig. 8: Connection manifold with gauges

The positioner can be matched to nearly all operating situations, such as a split range up to 4 ways, very long and very short strokes and angles of rotation of special cams, by means of a total of 5 range springs. The standard range spring fitted is the 420 494 019. Other range springs are available (Code FESG-FN, see page 16).

An attachment kit (Model Code EBZG-PN, -NN, -JN, -ZN or -RN) for rotary movement is required for attachment to rotary actuators and rotary armatures.



Fig. 9: Housing of the attachment kit for rotary movement

The Inductive limit switch **57** (Code R, T, U) and the limit switch with two microswitches (Code V) in addition enables end position signalling.

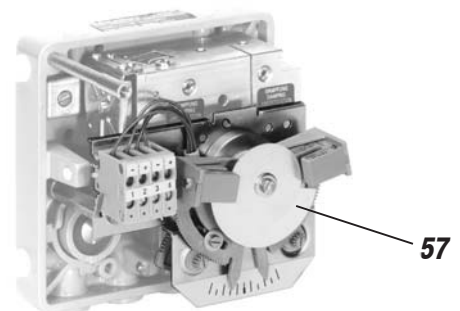

Fig. 10: Positioner with limit switches

The position transmitter 4-20 mA **58** (Model Code W) signals the stroke or angle of rotation via a standard electrical signal of 4 to 20 mA.

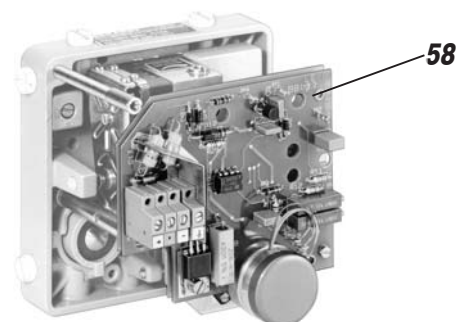
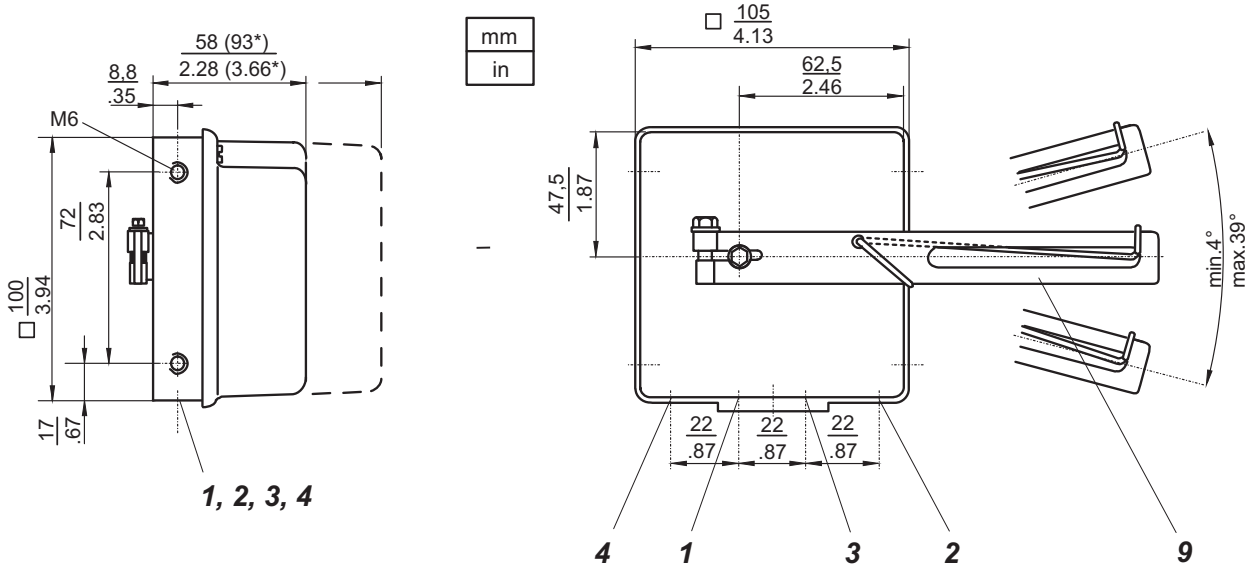

Fig. 11: Positioner with position transmitter 4-20 mA

2 MOUNTING

2.1 Dimensions

2.1.1 Positioner



Front view

Code L

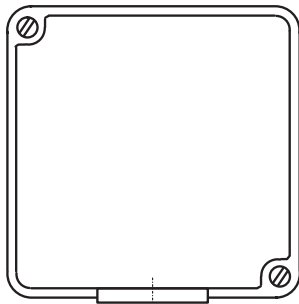

Code M, N

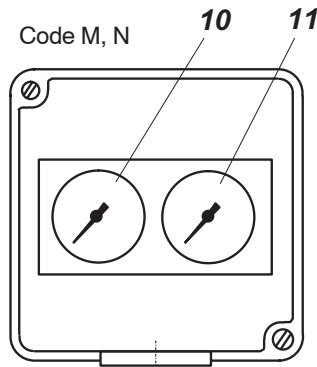

- 1 Female thread G 1/8 for supply air
- 2 Female thread G 1/8 for input (w)
- 3 Female thread G 1/8 for output I (y1)
- 4 Female thread G 1/8 for output II (y2) (only on double acting positioner)
- 9 Feedback lever
- 10 Gauge for input
- 11 Gauge for output

* Dimension with built-in gauges (optional, only on single acting positioner)

2.1.2 Options

“Built-in limit switch”,
Model Code R, T, U, V

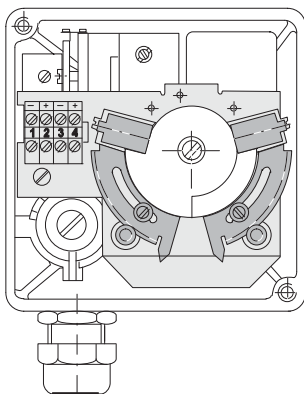

“Position transmitter”,
Model Code W

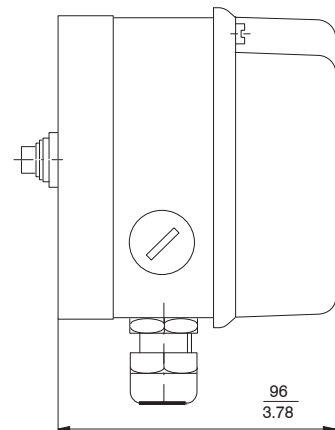
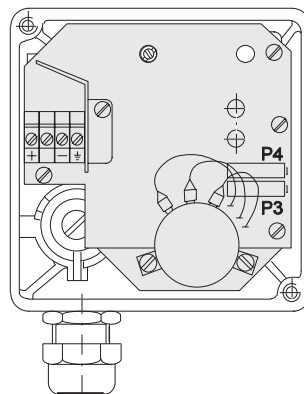

2.1.3 Additional parts

Connection manifold 1/4-18NPT with staggered connections, Code LEXG-BN

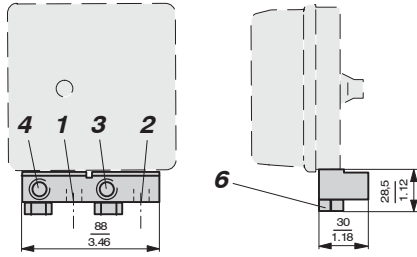

Connection manifold 1/4-18NPT with connections same level, Code LEXG-CN

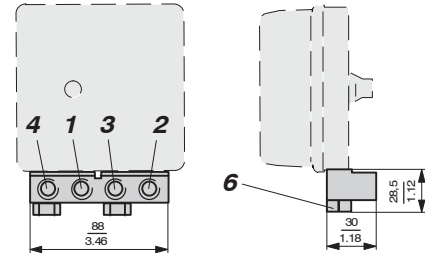

Booster relay single acting, Code VKXG-FN

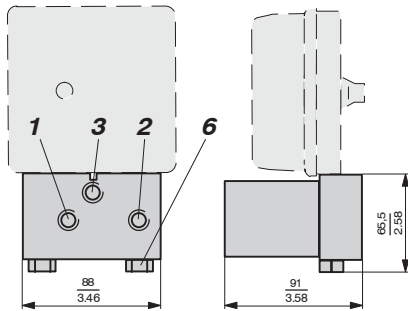

Booster relay double acting, Code VKXG-GN

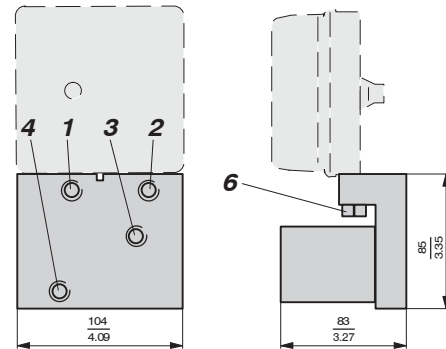

Booster relay single acting with doubled output capacity, Code VKXG-HN

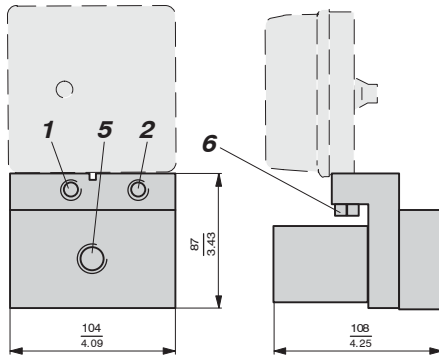

- 1 Female thread 1/4-18 NPT for supply air
- 2 Female thread 1/4-18 NPT for input (w)
- 3 Female thread 1/4-18 NPT for output I (y1)
- 4 Female thread 1/4-18 NPT for output II (y2)
- 5 Female thread 1/2-14 NPT for output I (y1)
- 6 Fixing screws 17 mm A/F

mm
in

Connection manifold 1/4-18NPT with gauges Code LEXG-JN, -KN, -LN, -MN, -NN
Connection manifold 1/4-18NPT for gauges Code LEXG-RN, -SN, -TN

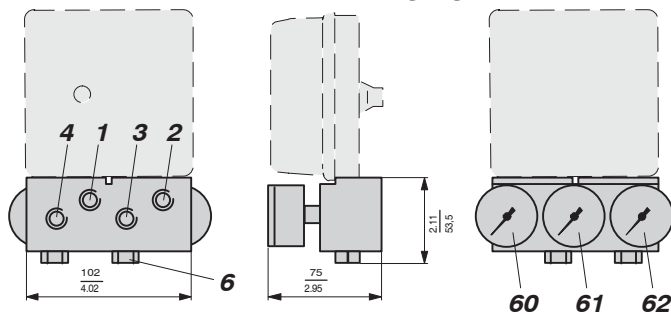

| Connecting manifold Code LEXG | 60 Gauges for | 61 Gauges for | 62 Gauges for | Version of action |
|-------------------------------|---------------|---------------|----------------|-------------------|
| -JN (-RN*) | without | Output (y) | Supply air | single |
| -KN (-RN*) | Input (w) | without | Supply air | single |
| -LN (-RN*) | Input (w) | Output (y) | Supply air | single |
| -MN (-SN*) | Supply air | Output I (y1) | Output II (y2) | double |
| -NN (-TN*) | Input (w) | Output I (y1) | Output II (y2) | double |

*) Connection manifold for gauges; without gauges

2.2 ATTACHMENT KIT FOR DIAPHRAGM ACTUATORS FOR STROKE MOVEMENTS

2.2.1 Dimensions

Attachment to casting yoke
according to IEC 534-6 (NAMUR)
Code EBZG-GN

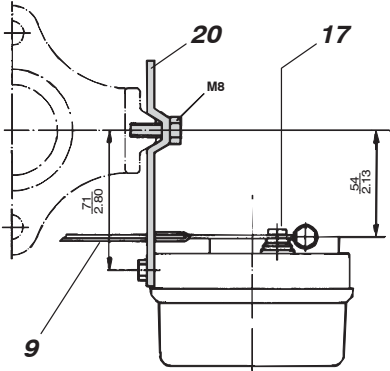

Attachment to pillar yoke
according to IEC 534-6 (NAMUR)
Code EBZG-FN

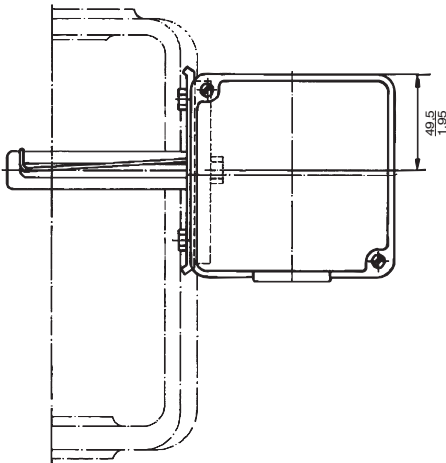
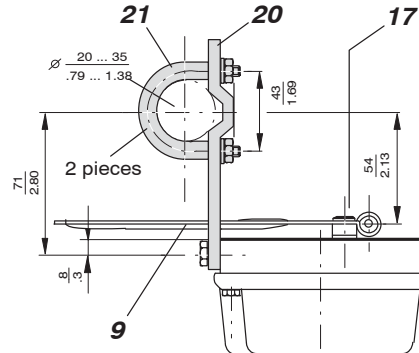

Feedback lever
Code EBZG-AN, -FN, -GN
Code EBZG-BN (extended version)

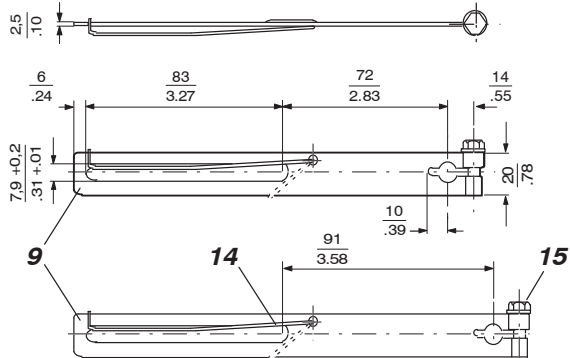

Mounting bracket
according to IEC 534-6 (NAMUR)
for Code EBZG-GN, FN

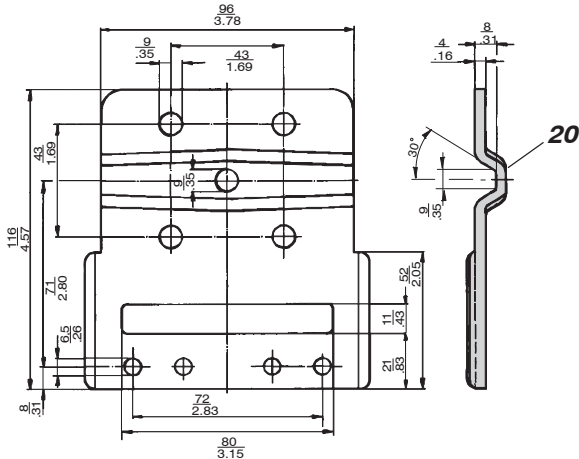

| |
|----|
| mm |
| in |



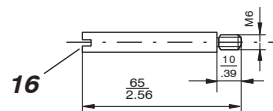





Carrier bolt
for attachment to valve stem



2.2.2 Determining the mounting side

Single acting diaphragm actuators

Check whether the actuator is in the safety position required by the process (Does the actuator open or close with spring force?). The mounting side is selected from the table below in accordance with the direction of action and the required direction of movement of the spindle for an increasing input signal.

| Actuator closes with spring force | Changeover plate setting | Actuator opens with spring force | Changeover plate setting |
|---|---|---|---|
|  |  |  |  |
|  |  |  |  |

The arrow indicates the direction of movement of the spindle for an increasing input signal.

The direction of action of the input signal can be set on the changeover plate **50** (see page 31):

- N = normal direction of action
(increasing input signal produces increase in control pressure to the actuator)
- U = reverse direction of action
(increasing input signal produces decrease in control pressure to the actuator)

Double acting diaphragm actuators

With double acting positioners the changeover plate **50** (see page 31) always stays in the "N" setting. The assignment of the input signal to the direction of movement of the actuator spindle is determined by the selection of the mounting side for the positioner and the piping of the positioner outputs to the actuator:

If the actuator spindle is to travel out with an increasing input signal, output y1 is connected on the top of the actuator and output y2 is connected on the bottom. The positioner is mounted on the right-hand side.

If the actuator spindle is to retract with an increasing input signal, output y1 is connected on the bottom of the actuator and output y2 is connected on the top. The positioner is mounted on the left-hand side.

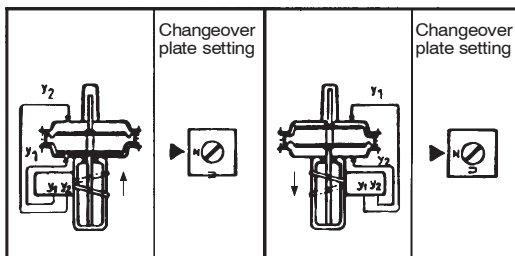

The arrow indicates the direction of movement of the spindle with an increasing input signal.

2.2.3 Attachment to diaphragm actuators

The positioner is attached using the attachment kit for diaphragm actuators according to DIN IEC 534-6 on the right-hand or left-hand side of the actuator.

- Screw carrier bolt **14** into the actuator coupling. (see page 8).
- Screw the attachment plate **20** to the positioner using two M6 socket head screws.
- Fasten the positioner with attachment plate **20** to the diaphragm actuator.
For FOXBORO ECKARDT-diaphragm actuators with casting yokes:
Fasten the attachment plate **20** using M8 screw to the threaded hole of the casting yoke (see page 8). This ensures that the feedback lever **9** is horizontal at a 50 % stroke.
For diaphragm actuators with pillars:
Fasten attachment plate **20** using two U-bolts **21** in such a manner that the feedback lever **9** loosely attached on the shaft **17** of the positioner and the carrier bolt **16** is horizontal at a 50 % stroke (see page 8).
- Set the actuator to a linear position of 0 %.
Attach the feedback lever **9** on the shaft **17** of the positioner and the carrier bolt **16** in such a manner that the compensating spring **14** is above the carrier bolt **16**, when the mounting side is on the right, and below the carrier bolt **16** when the mounting side is on the left (see Fig. 17).
- Press the stroke factor lever **31** against the stop bolt **30**, and create a friction-type connection between the feedback lever **9** and the shaft of the positioner by tightening the Allen screw **15** (A/F 10). See page 31.
- With single acting diaphragm actuators connect positioner output y1 to the diaphragm actuator; with double acting diaphragm actuators connect outputs y1 and y2.
- Connect command variable w (input).
- Connect supply air of min. 1.4 bar to max. 6 bar, but do not exceed the maximum permissible operating pressure of the diaphragm actuator.
- Screw on the housing cover in such a way that the air vent of the attached device faces downwards (see mark 'M' in Fig. 17).

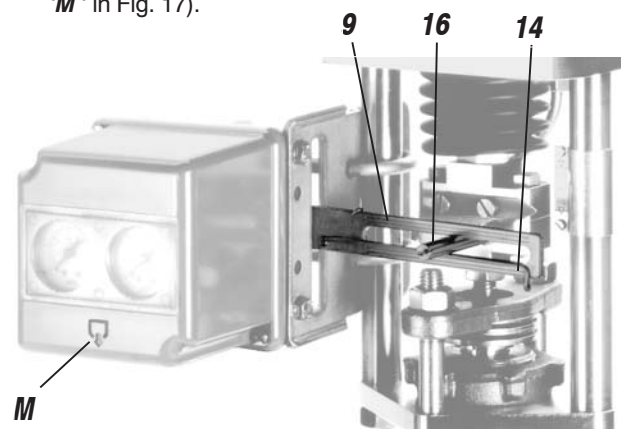
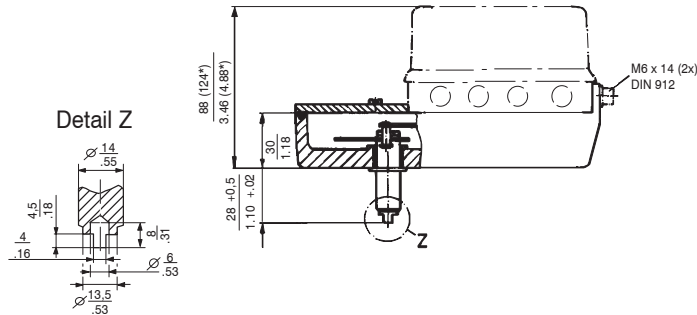

Fig. 17: Pillar yoke, mounting side left

2.3 ATTACHMENT KIT FOR ROTARY ACTUATORS

2.3.1 Dimensions

With shaft
(according to VDI/VDE 3845)
Code EBZG-ZN



Housing dimensions
Attachment kit with shaft
resp. without flange
Code EBZG-NN

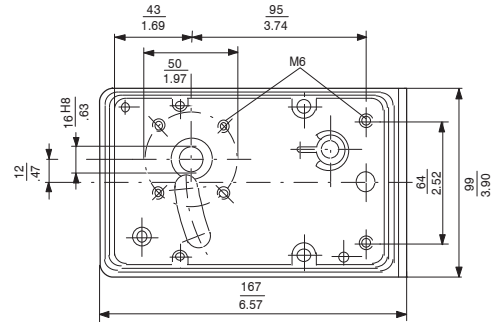

Without flange
Code EBZG-NN, -PN

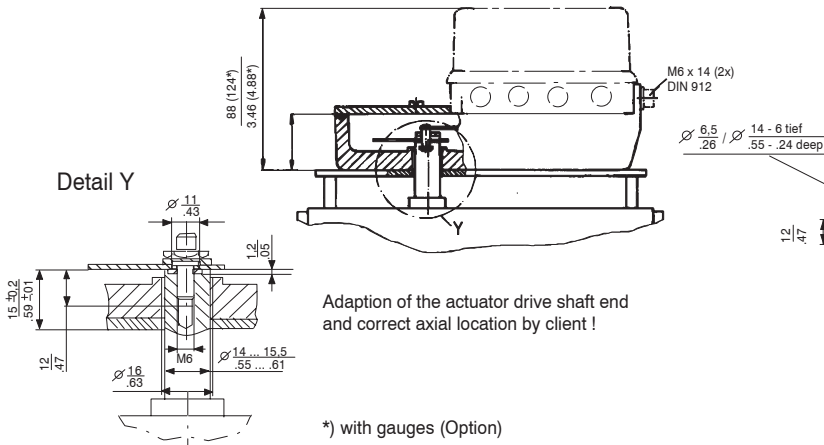

Housing dimensions
Attachment kit without flange
Code EBZG-PN

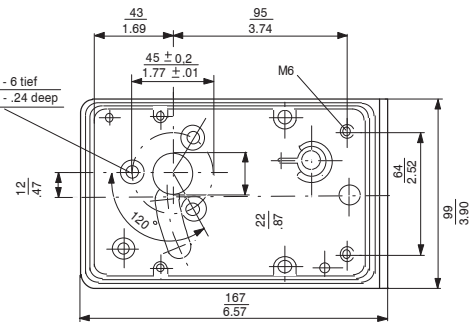

With flange
Code EBZG-JN

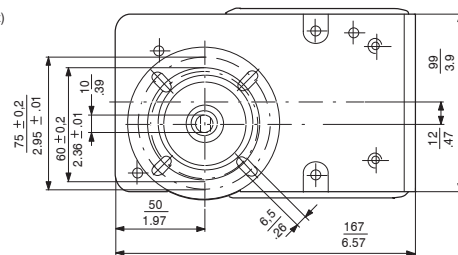
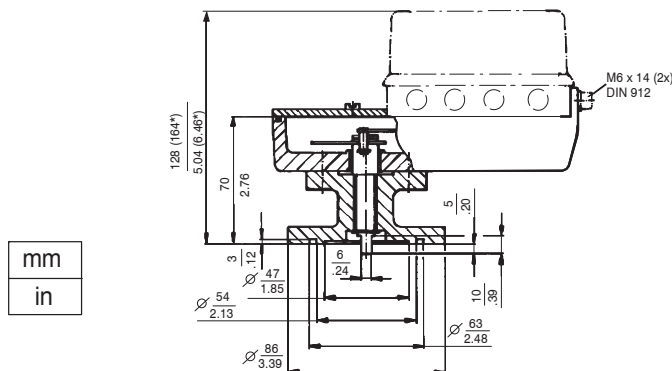

Rotation angle max 120°; torque requirement 14 Nm

Attachment kit for rotary actuators

For attachment of the positioner to rotary actuators or rotary armatures an attachment kit is required. The linear cam enables sensing of rotation angles up to 120°, whilst the equal percentage and the inverse equal percentage cams sense rotation angles up to 90° (linear characteristic between 70° and 90°).

2.3.2 Attachment to rotary actuators

- a) Remove the transparent cover plate from the housing of the attachment kit 26.
- b) Mount the housing of the attachment kit on the rotary actuator or the armature; use the mounting hardware supplied by the actuator manufacturer if necessary.

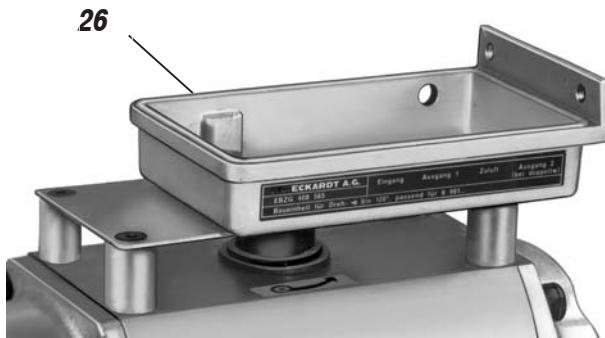

Fig. 19: Rotary actuator with attachment kit for rotary actuators

- c) Move the actuator into the desired starting position (rotation angle = 0°).
- d) Mount the cam 24 in accordance with the direction of rotation of the actuator (see Fig. 20).
The linear cam is fastened to the actuator drive shaft in such a manner that the dimension for x or y (Fig. 16) is 2 mm, whereas in the case of the inverse equal percentage cam the dimension x ≈ 17.5 mm and the dimension y ≈ 21.5 mm.
In the case of the inverse equal percentage cam the dimension x ≈ 18 mm and y ≈ 23 mm.
When employing the equal percentage and the inverse equal percentage cams, the range spring 420 493 013 supplied in the accessory bag must be installed in the positioner.

A = Mounting position for actuator rotation ↺

B = Mounting position for actuator rotation ↻

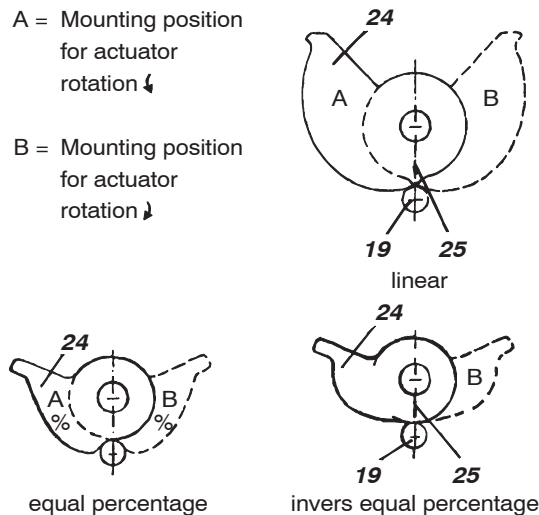

Fig. 20: Mounting position of the cams

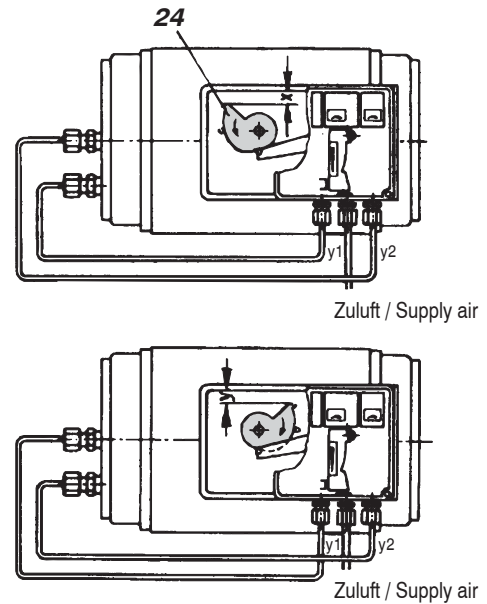

Fig. 21: Rotary actuator with attachment kit for rotary movement and double acting positioner. For direction of rotation see arrow on cam

- e) Fasten the feedback lever 9 for the rotary actuator onto the shaft of the positioner 17 as shown in Fig. 22.

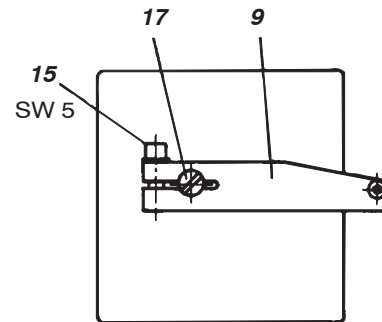

Fig. 22: Attaching the feedback lever to the positioner

- f) Mount the positioner on the housing of the attachment kit 26. Attach the spring 18 to the feedback lever 9 and the cam follower 19 against the cam (see Fig. 23).



Fig. 23: Attachment of the positioner

Screw the positioner to the housing of the attachment kit (see Fig. 25). With the linear cam and the inverse equal percentage cam check whether the mark **25** points to the centre of the cam follower **19** (see Fig. 20); adjust if necessary.

With the equal percentage cam check whether the cam follower lies directly ahead of the start of the cam lobe; adjust if necessary.

- g) Final mounting of the feedback lever **9** on the shaft of the positioner is performed at a stroke of 0 %, i. e. a rotation angle of 0°. First loosen the 5 mm A/F Allen screw of the feedback lever **9** through the hole **29** (see Fig. 24 and 25), then press the stroke factor lever **31** against the stop screw **30** and tighten the Allen screw firmly.
- h) With single acting actuators connect positioner output y1 with the actuator; with double acting actuators connect y1 and y2 with the actuator. Connect the chamber in which the pressure is to built up with an increasing input signal to y1.
- i) Connect command variable w (input).
- k) Connect supply air of min. 1.4 bar to max. 6 bar, but do not exceed the maximum permissible operating pressure of the actuator.

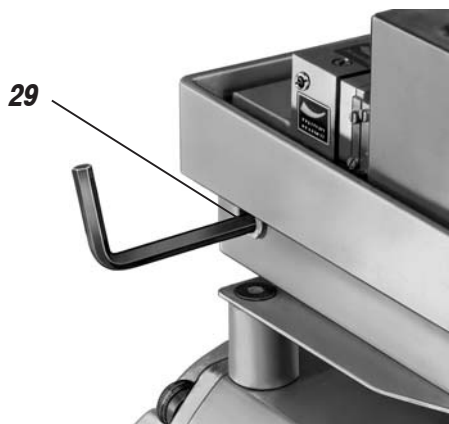

Fig. 24: Tightening the feedback lever

Note !

If the actuator moves to an end position, the mounting position of the cam does not coincide with the direction of rotation of the actuator. In this case install the cam **24** in the reverse position.

- l) Affix the red pointer **27** on the headed screw **28** in such a manner that 0° is indicated when the rotary actuator is in its starting position (w = 0).
- m) Attach the transparent cover plate.

2.3.3 Reversing the direction of rotation

Single acting actuator: Move the changeover plate **50** to the "U" setting and reverse the cam **24**.

Double acting actuators: Exchange the positioner outputs and reverse the cam (see Fig. 21). The changeover plate **50** remains in the "N" setting!

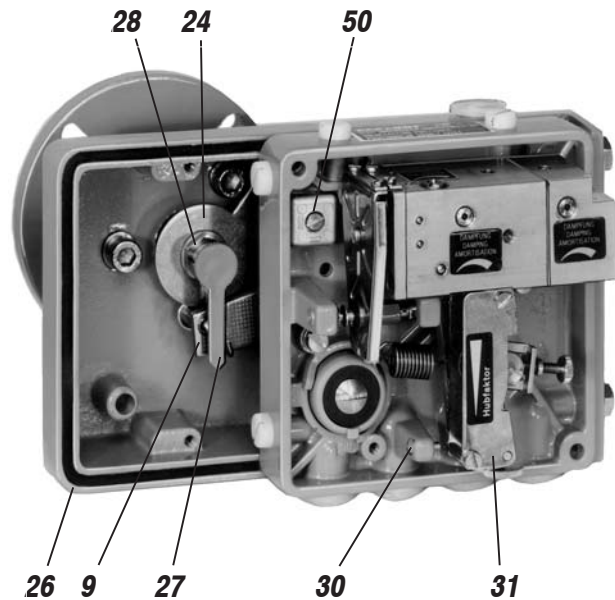

Fig. 25: Attachment kit for rotary movement and positioner

3 ELECTRICAL CONNECTIONS (of options)

Electrical connections are available for pneumatic positioners with the auxiliary equipment limit switch or position transmitter 4-20mA.

Upon installation, the installation requirements of DIN VDE 0100 resp. DIN VDE 0800 as well as locally applicable requirements, must be observed.

In addition, the requirements of VDE 0165 must be observed for systems associated with hazardous areas.

Further important instructions are contained in page 29 (Safety requirements, Explosion protection).

If an earth connection or potential equalization is required, the appropriate connections must be set up.

The unit must be operated in a fixed position.

The cable feeds in through a screwed gland Pg 13.5. This is suitable for line diameters of 6 to 12 mm.

The electrical connections are suitable for wire cross-sections of up to 2.5 mm².

3.1 Option “Built-in limit switches”

Connection terminals see page 23.

3.2 Option “Position transmitter”

Model Code W

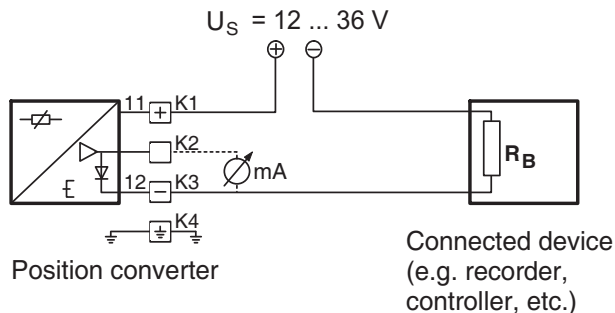

Connection terminals

- K1 (+) } Power supply
- K3 (-) }
- K2 (+) } Test of the output signal without interruption.
- K3 (-) } A low load ampere meter ($R_i \leq 10 \Omega$) can be used.
- K4 \perp Earth connection

3.2.1 Direct power supply

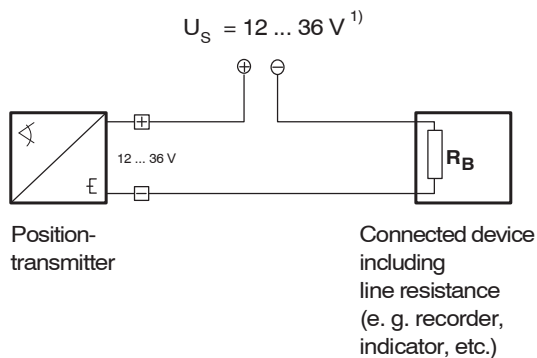

The max. load impedance R_{Lmax} is calculated per:

$$R_{Bmax} = (U_S - 12 V) / 0.02 A \text{ [Ohm]}$$

Load characteristic for direct supply

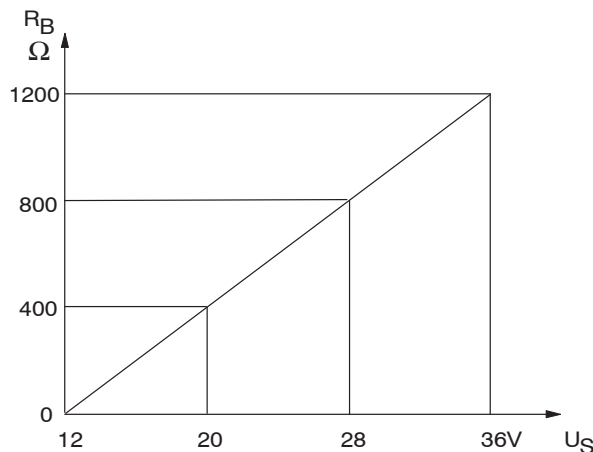

3.2.2 Supply with Power Supply Unit

For intrinsically safe applications, FOXBORO ECKARDT-Power Supply Units are available.

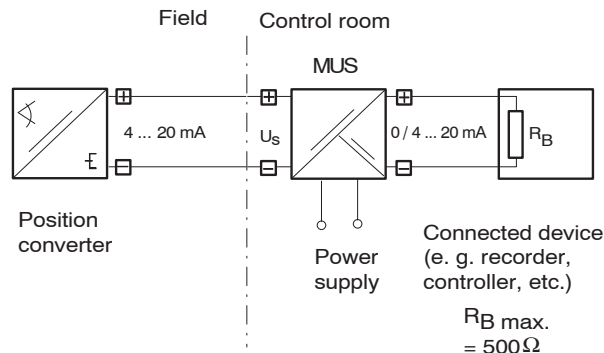

1) For explosionproof instruments observe the electrical limits, see Product Specifications PSS EVE0101 A.

4 COMMISSIONING

Before commissioning pneumatic positioners must be matched to the stroke or rotation angle of the actuator and the input signal range.

The supply air connected should be min. 1.4 bar and max. 6 bar, but should not exceed the maximum operating pressure of the diaphragm actuator.

4.1 Setting the amplification

The amplification and thus the sensitivity of the positioner are set by means of the throttling screw **42**. The throttling screw is screwed in right in the factory, i. e. it is set to maximum amplification.

This amplification varies with the supply air pressure, as shown in the following table:

| Supply air | Max. amplification | |
|------------|--------------------------|--------------------------|
| | Single acting positioner | Double acting positioner |
| 1.4 bar | approx. 150 | approx. 100 |
| 4 bar | approx. 90 | approx. 150 |
| 6 bar | approx. 60 | approx. 180 |

The linear amplification is indicated. These values are based on the built-in range spring FES 420 494 019.

From the basic setting the amplification can be matched to the dynamic requirements of the control system (counter-clockwise rotation of the throttling screw **42** results in less amplification).

Note!

The zero must be reset following each change of amplification.

In order to ensure reliable pressure reduction in the actuator, the throttling screw **42** should not be opened beyond the listed maximum values (with 6 bar max. ¼ ro). A limiting screw **43** is therefor incorporated.

The basic setting at the factory permits a maximum opening of the throttling screw **42** of approx. 1 turn.

4.2 Setting of zero and stroke

Before commencing settings press the flapper lever **35** several times alternately to the left and right in order to align the flappers correctly.

- Set the minimum value of command variable w (start of stroke)
- Turn the zero screw **39** until the actuator just begins to move from its end position.
- Set the maximum value of command variable w (end of stroke).
- Turn the stroke factor screw **40** until the actuator precisely reaches its end position.

Recheck the zero and stroke settings.

Note:

When the stop screw **20** is correctly positioned (see 5.1 or 5.2) and the feedback lever is correctly mounted (see 2.2.3 d / e) there is no interaction between the adjustments of zero and stroke.

If the stroke cannot be adjusted with the existing spring, the correct spring can be approximately determined in accordance with the following criteria:

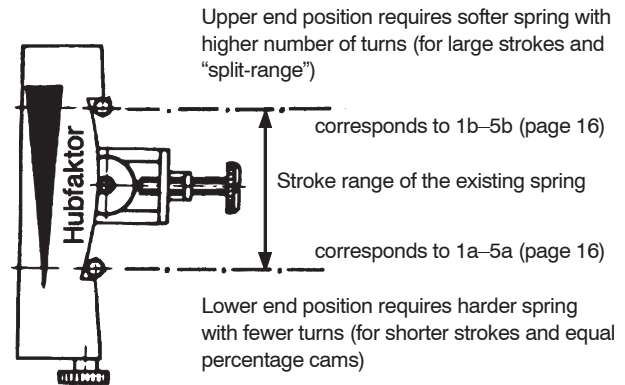

There are 5 differently rated springs available for matching to the stroke and input signal range. The particular spring **34** required can be determined precisely from the stroke factor U_x .

4.3 Setting the damping

The air output capacity of the positioner can be reduced by means of the damping throttle **44** (see page 31).

Double acting positioners are equipped with a damping throttle **44** for output y1 and a damping throttle **45** for output y2.

In its normal setting the damping throttle is approximately flush with the amplifier housing. The air output capacity is reduced by a factor of approximately 2.5 when the damping throttle is turned right in.

A reduction of the air output capacity should only be undertaken for very small actuator volumes, since the control system would otherwise be too sluggish.

4.4 Subdivision of the input range (split range)

If several actuators are to be controlled by the same command variable, and a complete stroke is to be made in only one specific subrange of this command variable at a time, each actuator must be provided with a positioner, on which the zero and stroke range must be set to the desired sub-range of the command variable.

In the case of positioners which are attached to FOXBORO ECKARDT valves, 4-way subdivision is possible with sub-ranges of 0.2 bar.

The range springs required can be selected on the basis of the stroke factor range or the spring graph (see page 16).

If the zero point must be elevated to **greater than 0.6 bar** as the result of the subdivision of the input range, the setting should be performed as follows:

- Shut off supply air.
- Remove tension from the range spring **34** by turning the zero screw **32**.
- Loosen the A/F 10 screw of the feedback lever and turn the stroke factor lever **31** away from the stop screw **30**. This applies pretension to the range spring **34** (see Fig. 31). In this position retighten the screw of the feedback lever.
- Connect supply air.
- Set the minimum value of command variable w (start of stroke).

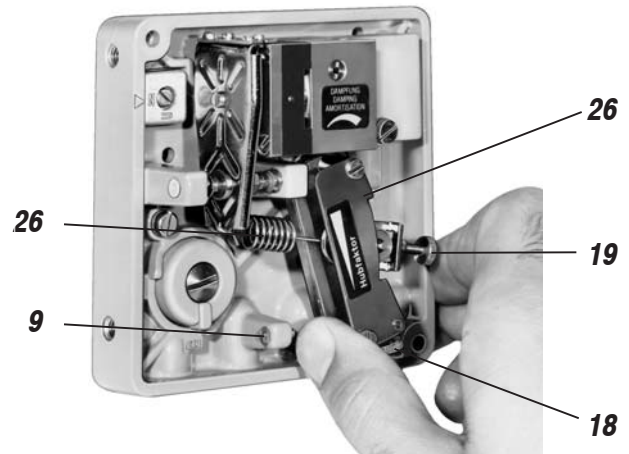

Fig. 31: Pretension of the range spring

- Turn the zero screw **32** until the actuator begins to move away from its end position. If this is not possible, the pre-tension of the range spring must be increased as described under c).
- Set the maximum value of command variable w (end of stroke).
- Turn the stroke factor screw **33** until the actuator reaches its end position precisely.

Note!

At this setting the zero and stroke range are mutually dependent. Settings e) to h) should therefore be repeated as often as necessary until both settings are correct.

Furthermore it should be noted that the deflection of the stroke factor lever **31** from the starting position may not exceed a maximum of 39 degrees, since the stroke factor lever might otherwise touch the housing cover before reaching its end position.

4.5 Determining of the rotation angle factor U_φ

In conjunction with the attachment kit for rotary actuators (Code P, M, J, Z, R) the rotation angle factor U_φ can be determined as follows:

$$U_\varphi = \frac{\varphi}{\Delta w} = \frac{\text{Rotation angle } [\angle^\circ]}{\text{Input signal range [bar]}}$$

The rotation angle factors U_φ of the individual range springs are given in the table on page 16. The rotation angles are also taken into account in the graph of the range springs (see page 16).

4.6 Determination of the stroke factor U_x

The stroke factor U_x is the ratio of the entire range of the output variable (stroke x) to the entire range of the input variable (command variable w).

For FOXBORO ECKARDT diaphragm actuators PA200 to PA700 / 702 :

$$U_x = \frac{x}{\Delta w} = \frac{\text{Stroke in mm}}{\text{Input signal range in bar}}$$

For FOXBORO ECKARDT diaphragm actuator (1500 cm²) and other manufacturers ($l_0 = 117.5$ mm):

$$U_x = \frac{x}{\Delta w} \times \frac{l_0}{l_s}$$

l_s = Feedback lever length in mm (for FOXBORO ECKARDT-actuator 1500 cm²: $l_s = 122.5$ mm)

l_0 = Standard feedback effective length

The stroke factor can be used to determine for each application whether or with which spring the desired setting can be made.

Five different range springs are available for matching to the stroke and input signal range.

4.6.1 Stroke factor ranges of the range springs

The stroke factor U_x determined as described in 4.6 should lie within the ranges of the respective range springs indicated in the following table, as close as possible to the lower value.

| Range spring | | | | Cam 1) | | Stroke factor ranges | | Remarks |
|--------------|-------------|-----------|-------------|-------------------------------------|----------------------------------|----------------------------------|--------------------------|----------|
| Ident No. | old ID | Colour | linear | Equal perc. and inverse equal perc. | Stroke factor U_x mm bar | Stroke range ²⁾ mm | | |
| | | | max. 120° | max. 90° | | | | |
| 1 | 420 493 013 | FES 627/1 | yellow | 1.7 ... 4.7 (max. 7) | 2.4 ... 8 (max. 10) | 10 ... 30 (max. 42) | 8 ... 34 | 3) |
| 2 | 420 494 019 | FES 628/1 | green | 3.5 ... 9.5 (max. 14) | 5 ... 15 (max. 20) | 22 ... 60 (max. 84) | 17 ... 68 | built-in |
| 3 | 502 558 017 | FES 612/1 | - without - | 5.8 ... 14.5 (max. 21.75) | 8.2 ... 24 (max. 28) | 35 ... 90 (max. 130) | 28 ... 105 | 3) |
| 4 | 420 496 011 | FES 715/1 | gray | 8.4 ... 21.5 (max. 32.75) | 12 ... 35 (max. 43) | 50 ... 140 (max. 190) | 40 ... 158 ⁴⁾ | 3) |
| 5 | 420 495 014 | FES 629/1 | blue | 11.5 ... 27.5 (max. 41.5) | - | 70 ... 180 (max. 250) | 55 ... 200 ⁴⁾ | 3) |

1) For equal percentage and inverse equal percentage cams the rotation angle factors are a function of their corresponding rotation angles.

2) For feedback effective length $l_s = 117.5$ mm and $\Delta w = 0.8$ bar

3) Included in FESG-FN (Id No. 407 083 013)

4) Theoretical value

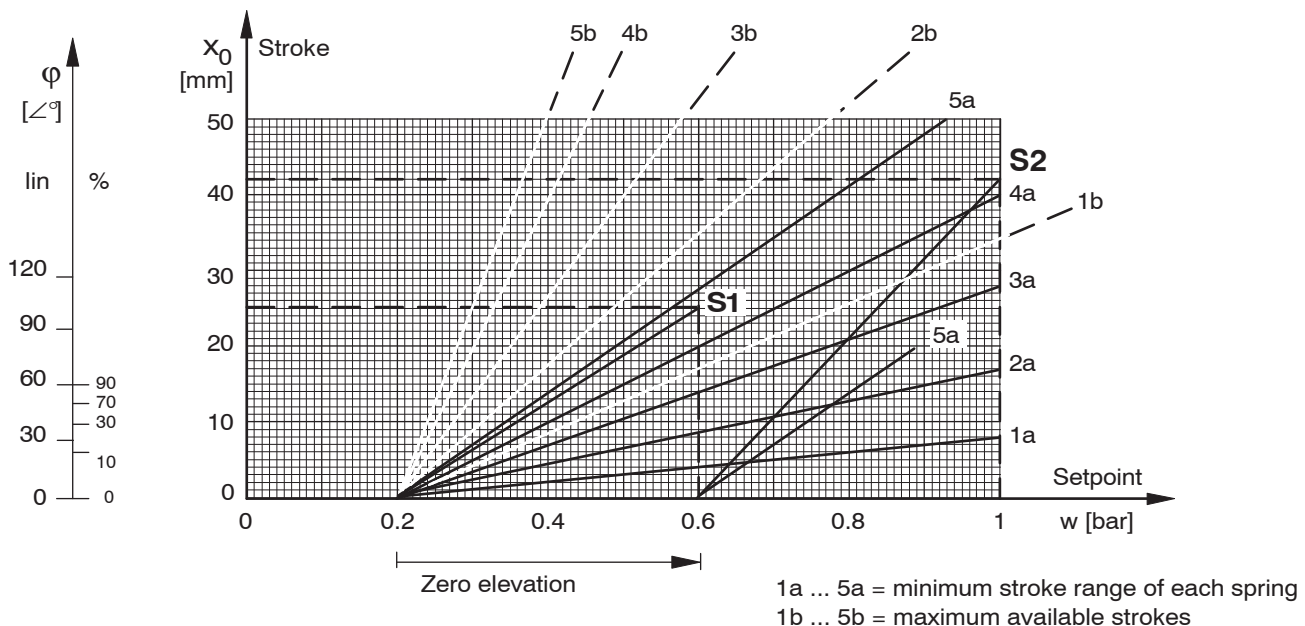

1a ... 5a = minimum stroke range of each spring

1b ... 5b = maximum available strokes

4.6.2 Characteristics of the range springs

The stroke x_0 is based on the FOXBORO ECKARDT- standard feedback lever effective length $l_0 = 117.5$ mm.

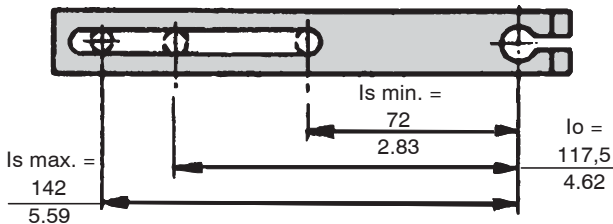

Fig. 33: Feedback lever

If another length (l_s) is used, the actual stroke x_s must be converted to the stroke x_0 :

$$x_0 = \frac{117,5 \times x_s}{l_s} \text{ [mm]}$$

Selection of measuring spring and setting of span

Determination of suitable spring for split range:

- Enter desired setpoint value w for travel start in the diagram field.
- Determine x_0 if l_s unequal 117.5 mm.
- Enter intersection w/x_0 .
- Connect points determined at a) and c). This results in a straight line.
- If the straight line does not run through the origin, move this parallel here.
- Use the spring the characteristic line (a) of which is located directly below the presently determined characteristic line.

Example: Split-range-operation

(shown in graph)

Valve 1:

$w = 0.2 \dots 0.6$ bar
 $x_s = 30$ mm (stroke range)
 $l_s = 140$ mm

$$x_0 = \frac{117,5 \times 30}{140} = 25,2 \text{ mm}$$

Intersection $w = 0.6$ bar with $x_0 = 25.2$ mm → **S1**

Selected: spring 4 (FES 420 496 011, grey), because the characteristic curve, based on the begin of the determined straight line, lies directly beneath of them.

Valve 2:

$w = 0.6 \dots 1.0$ bar
 $x_s = 50$ mm (stroke range)
 $l_s = 140$ mm

$$x_0 = \frac{117,5 \times 50}{140} = 42 \text{ mm}$$

Intersection $w = 1.0$ bar with $x_0 = 42$ mm → **S2**

Selected: spring 5 (FES 420 495 014, blue), because the characteristic curve, based on the begin of the determined straight line, lies directly beneath of them.

4.7 Manual bypass switch

The single acting pneumatic positioner can also be supplied with a bypass switch **51** (see page 31) if it is intended for use with actuators with a signal range of 0.2 ... 1 bar.

In the "ON" position the actuating signal of the master controller is supplied via the positioner; in the "OFF" position it is connected direct to the actuator.

Note!

The bypass switch may only be operated in the normal direction of a action (changeover plate **50** in position N, see page 31), i. e. when the "OFF" position is set.

It should also be noted that the stored pressure in the actuator chamber may have a feedback effect on the preceding controllers when the "OFF" position is set, and could overload them. The pressure in the actuator chamber should therefore be reduced accordingly before the changeover. The spring range of the actuator should not exceed the maximum signal value of the master controller, in order to ensure that the valve can open and close fully.

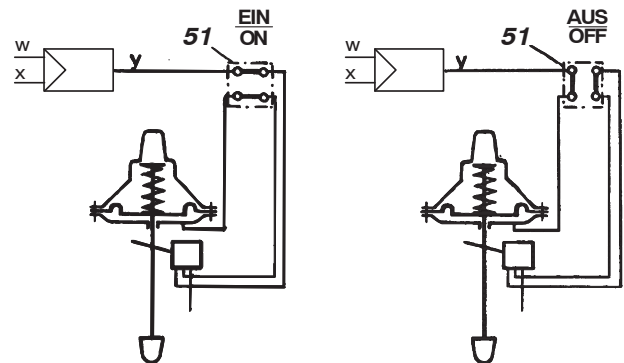

Fig. 34: Bypass circuit

5 MAINTENANCE

5.1 Basic adjustment of the single acting positioner

A basic adjustment is only required when the device has been disassembled or subassemblies have been exchanged. All settings performed in order to match the positioner to the actuator are described in chapter 4 Commissioning, page 14.

The following tools are required for the basic adjustment:

- 1 screw driver
- 1 set spanner A/F 7
- 1 feeler gauge 0.6 mm
- 2 pressure test gauges 1.6 bar
- 1 signal generator 0.6 bar

If adjustments are made with the device attached, the feedback lever on the shaft of the positioner must be loosened.

- a) Set the changeover plate **50** to "N".
 - b) Turn the throttling screw **42** clockwise as far as its stops (maximum amplification).
 - c) Unhook the range spring **34** from the flapper lever **35**.
 - d) Check that the flappers **37** are aligned concentrically with the nozzles **36**. If necessary loosen the mounting bolts of the amplifier on the rear of the positioner and align the amplifier accordingly.
 - e) Press the flapper lever **35** several times alternately to the left and right, so that the ball-guided flappers are parallel to the nozzles.
 - f) Press the flapper lever **35** to the left. Set the clearance between the right-hand nozzle and the right-hand flapper to 0.6 mm with the aid of a feeler gauge by turning the hexagonal nut **56** A/F 7. Then secure the nut against further turning.
 - g) Connect the positioner as shown in the test circuit in Fig. 35. Connect supply air of 1.4 bar.
 - h) Press the flapper lever **38** to the left. If the output y does not rise to the level of the supply air pressure, either leaks are present or the flapper is not correctly aligned (repeat e)).
- i) Hook the range spring **34** onto the flapper lever **35** and connect $w \approx 0.6$ bar.
The following procedure must be observed in order to achieve a no-feedback adjustment of the zero and stroke settings:
 - k) Press the stroke factor lever **31** against the stop screw **30**.
 - l) Set the stroke factor screw **33** to a high stroke factor (approx. 2 mm before the upper stop).
 - m) Turn the zero screw **32** until the output pressure $y \approx 0.6$ bar, and make a note of this value.
 - n) Set the stroke factor screw **33** to a low stroke factor (approx. 2 mm before the lower stop).
The output pressure y may not vary by more than ± 150 mbar as compared with the setting described in m).
 - o) In case of excessive deviations the stop screw **30** should be adjusted.
Whenever the stop screw **30** is adjusted, the settings described in l) to n) should be repeated until the deviation is less than ± 150 mbar.
 - p) Secure the stop screw **30** with sealing paint.

Return the changeover plate **50** to its original position. Re-attach the positioner or fasten the feedback lever back onto the shaft of the positioner see chapter 4, page 14.

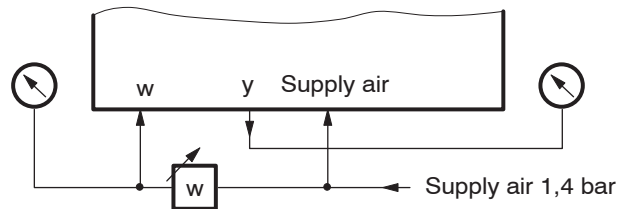

Fig. 35: Test circuit

5.2 Basic adjustment of the double acting positioner

A basic adjustment is only required when the device has been disassembled or subassemblies have been exchanged. All settings performed in order to match the positioner to the actuator are described in chapter 4 Commissioning, page 14.

The following tools are required for the basic adjustment:

- 1 screw driver
- 1 set spanner A/F 7
- 1 feeler gauge 0.6 mm
- 3 pressure test gauge (2 x 6 bar, 1 x 1.6 bar)
- 1 signal generator 0.6 bar

If adjustments are made with the device attached, the feedback lever on the shaft of the positioner must be loosened.

- a) Set the changeover plate **50** to "N".
- b) Turn the throttling screw **42** clockwise as far as it stops (maximum amplification).
- c) Unhook the range spring **34** from the flapper lever **35**.
- d) Check that the flappers **37** are aligned concentrically with the nozzles **36**. If necessary loosen the mounting bolts of the amplifier on the rear of the positioner and align the amplifier accordingly.
- e) Press the flapper lever **35** several times alternately to the left and right, so that the ball-guided flappers are parallel to the nozzles.
- f) Press the flapper lever **35** to the left. Set the clearance between the right-hand nozzle and the right-hand flapper to 0.6 mm with the aid of a feeler gauge by turning the hexagonal nut **56** A/F 7. Then secure the nut against further turning.
- g) Connect the positioner as shown in the test circuit in Fig. 36. Connect supply air of 1.4 bar.
- h) Press the flapper lever **35** to the left and the right. The pressures y_1 and y_2 should vary in opposite directions between 0 bar and the supply air pressure.
- i) Hook the range spring **34** onto the flapper lever **35** and connect $w \approx 0.6$ bar.
- k) Set the zero screw **32** until the pressures y_1 and y_2 are equal.

- l) Set the adjusting screw **47** so that the pressures y_1 and y_2 are approx. 4.2 bar (70 % of the supply air pressure).
If necessary repeat the settings described in k) and l) alternately.
- m) Connect supply air of 1.4 bar. Set the zero screw **32** so that the pressures y_1 and y_2 are equal. They should be approximately 0.7 bar (50 % of the supply air pressure).
(Check measurement only.)
The following procedure must be observed in order to achieve a no-feedback adjustment of the zero and stroke settings:
 - n) Press the stroke factor lever **31** against the stop screw **30**.
 - o) Set the stroke factor screw **33** to a high stroke factor (approx. 2 mm before the upper stop).
 - p) Turn the zero screw **32** until the output pressures y_1 and y_2 are equal.
 - r) Set the stroke factor screw **33** to a low stroke factor (approx. 2 mm before the lower stop).
The output pressures y_1 and y_2 may not vary by more than ± 150 mbar as compared with the setting described in p).
 - s) In case of excessive deviations the stop screw **30** should be adjusted.
Whenever the stop screw **30** is adjusted, the settings described in o) to r) should be repeated until the deviation is less than ± 150 mbar.
 - t) Secure the stop screw **30** with sealing paint.

Reattach the positioner or fasten the feedback lever back onto the shaft of the positioner see chapter 4, page 14.

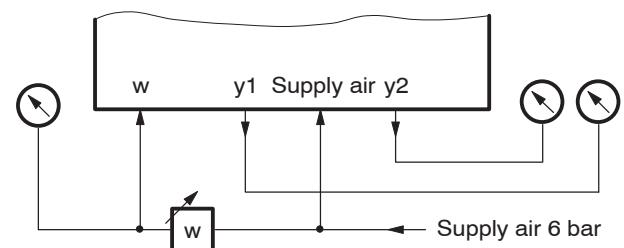

Fig. 36: Test circuit

5.3 Cleaning the throttle

- a) Remove the limiting screw **43**.
- b) Pull the throttling screw **42** down out of the limiting screw.
- c) Place the throttling screw **42** in a solvent (e. g. benzene) and blow through it carefully. It is better still to clean it in an ultrasonic bath.
- d) Turn the throttling screw **42** right in again as far as its stop (clockwise).
- e) Turn the limiting screw **43** right in clockwise as far as its stop, then back again counterclockwise by about half a turn.
- f) Secure the limiting screw **43** with sealing paint.

6 REPLACING SUBASSEMBLIES

6.1 Replacing the amplifier

- a) Remove the housing cover.
- b) Unhook the range spring **34** from the flapper lever **35**.
- c) Unscrew and remove the amplifier **40** or dual amplifier **41**. The two mounting bolts are accessible from the rear of the positioner.
- d) Install a new amplifier. Do not forget the O-rings between the amplifier and the base plate (air baffle). Before tightening the mounting bolts align the amplifier in such a way that the flappers **37** are concentrically aligned with the nozzles **36**.
- e) Hook the range spring **34** onto the flapper lever **35**.
- f) Perform a basic adjustment (see 5.1 or 5.2).

6.2 Replacing the amplifier diaphragm in the single acting positioner

- Remove the amplifier (see 6.1)
- Dismantle the amplifier.
Remove the screw **54**. Remove the two screws **56**.
Remove the strip **55** and flapper lever **35**.

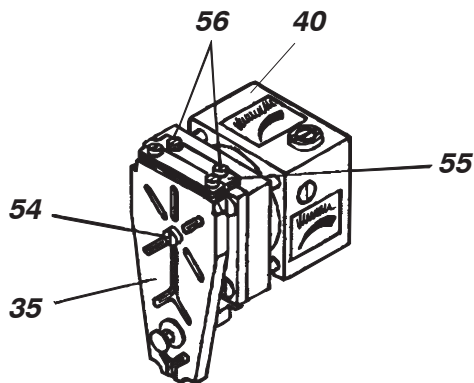

Fig. 37: Amplifier

When the four screws **63** are removed, the amplifier can be dismantled into the following components and subassemblies:

- 64** housing block A
- 65** pipe
- 66** spring
- 67** diaphragm disk subassembly
- 68** amplifier diaphragm
- 69** housing block B
- 70** input diaphragm subassembly
- 71** cover

- Reassemble the amplifier:
Reassemble the components and subassemblies in the correct position in the sequence specified. Replace faulty parts.

Put housing block **A 64** with the open side facing upwards. Insert pipe **65** in the hole in the housing block **A 64**. Place spring **66** in position in the diaphragm disk subassembly **67**. Insert diaphragm disk subassembly **67** in housing block **64** so that the pipe **65** passes through the holes in the diaphragm disk subassembly **67**. Place amplifier diaphragm **68** on the diaphragm disk subassembly **67** (with the projection facing downwards), pipe **65** should be inserted in the hole of the amplifier diaphragm **68**.

Place housing block **B 69** in its correct position, so that the pipe **65** is inserted in the relevant hole in housing block **B 69**. Press housing block **B 69** against housing block **A 64**.

Note:

When these two components are pressed together housing block **B 69** should be planeparallel with housing block **A 64**.

If not, why are they misaligned?

(Is pipe **65** in its correct position in the holes of housing block **A 64** and housing block **B 69**?)

Insert input diaphragm subassembly **70** in housing block **B 69**. Install cover **71** in the right way round (threaded holes on the amplifier setting side), and screw the amplifier together.

Tighten the four screws **63** uniformly.

- Screw on the flapper lever **35** again.
- Install the amplifier (see 6.1)
- Perform a basic adjustment (see 5.1)

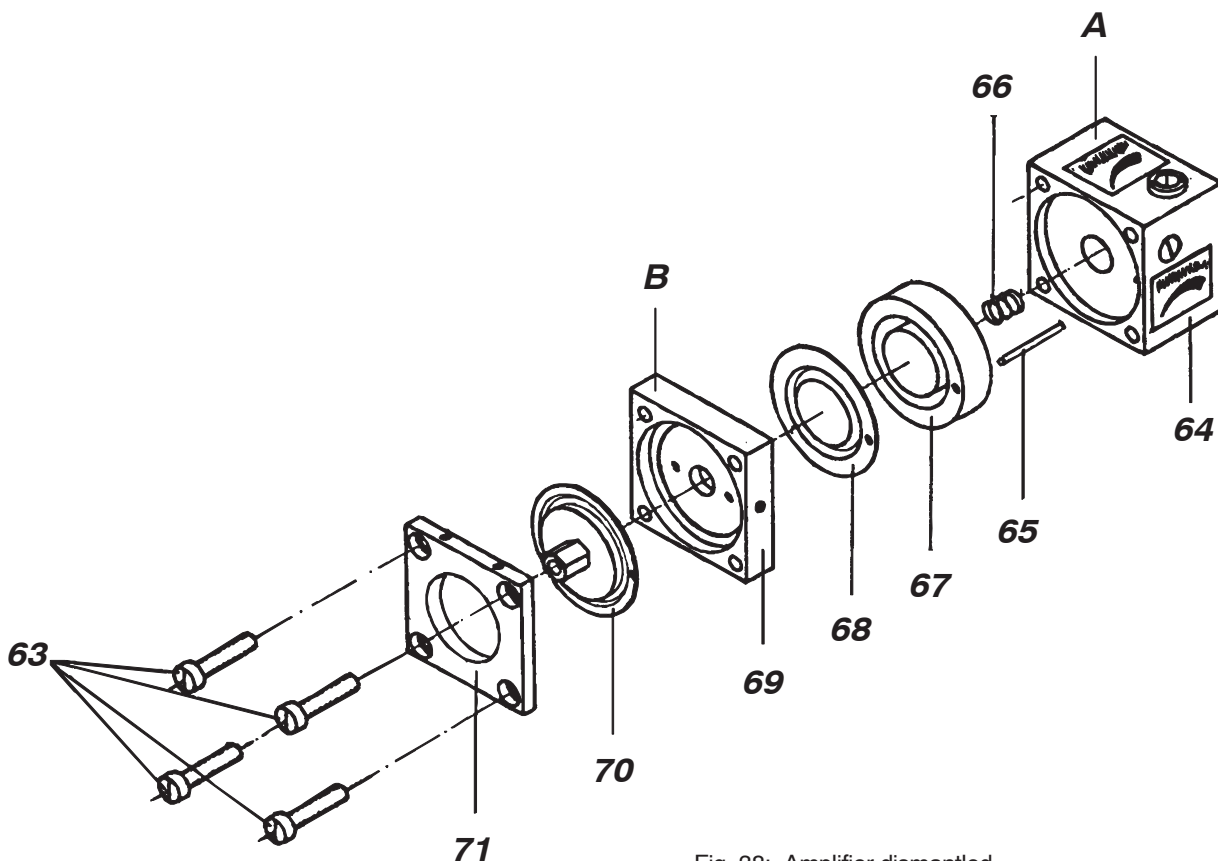

Fig. 38: Amplifier dismantled

6.3 Replacing the amplifier diaphragm in the double acting positioner

Remove the dual amplifier **54** (see 6.1)

Replace the input diaphragm

- a) Remove screw **54**.
- b) Remove two screws **56**, the strip **55** and the flapper lever **35**.

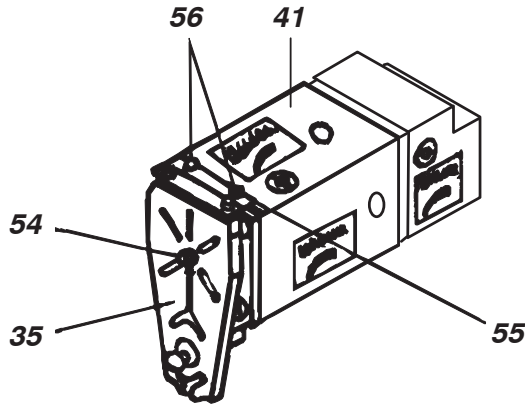

Fig. 39: Dual amplifier

- c) Remove four screws **72** and the cover **71**.
- d) Remove and replace the input diaphragm subassembly **70**.
- e) Reassemble the input diaphragm in the reverse order.

Replace the diaphragm assembly

- a) Remove four screws **73** and housing block A **74**.
- b) Remove spring washer **75**.
- c) Through the holes **76**, the diaphragm assembly **77** can be pressed out of the housing block B **78**, for example by means of a small screwdriver. The diaphragm assembly is a self-contained component, and should not be dismantled further.

- d) Insert the new diaphragm assembly **77** in its correct position in housing block B **78**.

Important note:

The pipe **79** passes through the first disk **80** and is inserted in a hole in the second disk **81**.

If the two disks **80** and **81** are not absolutely flush when the diaphragm assembly is pressed together by hand, the pipe is not in its correct position in the hole. In this case disk **81** should be turned until the pipe is correctly inserted in the hole.

- e) Install housing block A **74** in its correct position and screw on with the four screws **73**.
- f) Measure the gap between the housing blocks **74** and **78** with the aid of a feeler gauge.
- g) The spring washer **75** selected should have a wire diameter which corresponds to the gap measured as described in f), or which is no more than 0.1 mm smaller in diameter.
- h) Remove the four screws **73** again and remove housing block A **74**.
Install the spring washer **75** selected, replace housing block A **74** in its correct position, and tighten the screws **73** firmly and uniformly. Align the spring washer so that it does not project over the edges of the housing blocks **74** and **78**.

Reinstall the amplifier (see 6.1) and perform basic adjustment (see 5.2).

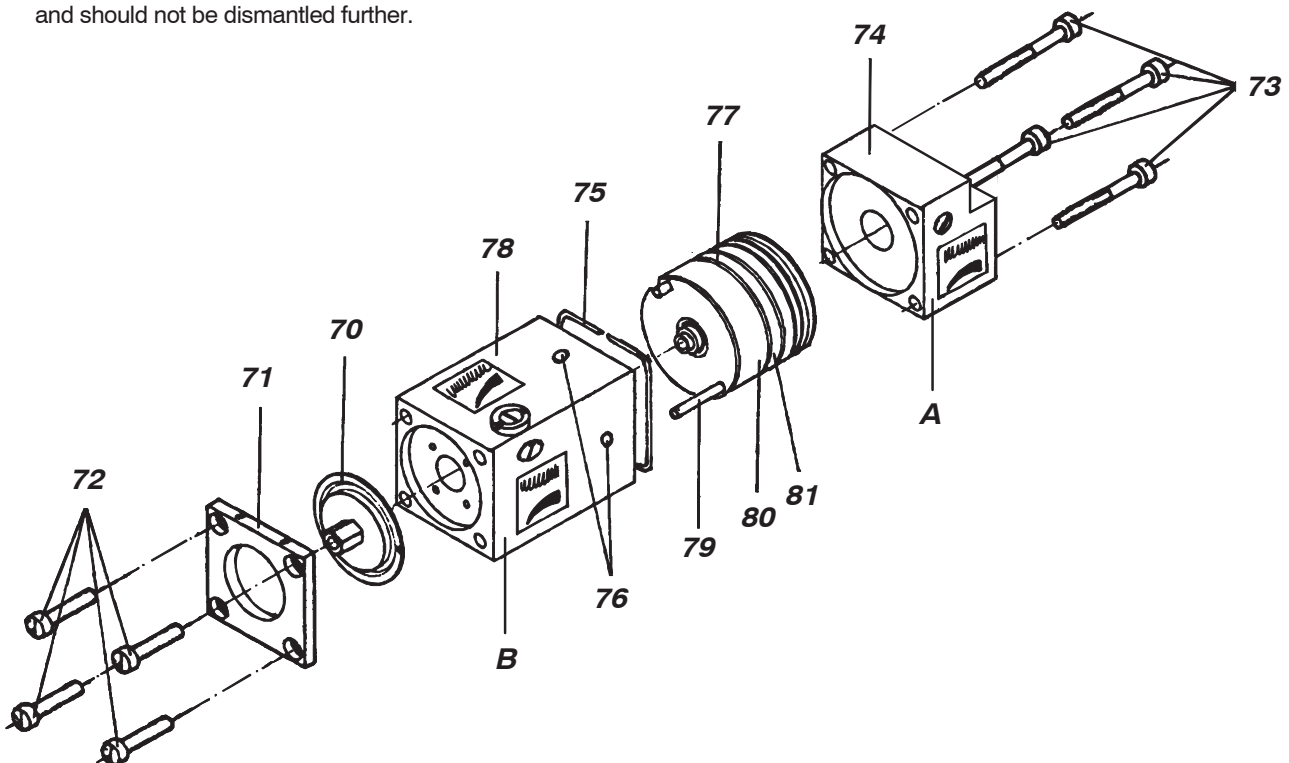

Fig. 39: Dual amplifier dismantled

7 Option “Limit switch”

The limit switches are additional equipment either installed in the factory or updated. They are constructed either with inductive switches or micro switches and signal exceeding or deceeding of a stroke or rotating movement of actuators.

7.1 Method of operation

Stroke or rotation angles of the actuators are transferred to the control vanes via a deviating mechanism to the control vanes which either dampen an oscillator circuit or switch a mechanical contact depending on the version.

The inductive limit switches are supplied with power via a separately mounted switch amplifier. The current signal is transferred into a switch output.

In the three-wire version an integrated switch amplifier supplies a switch signal; direction of reaction PNP closing function.

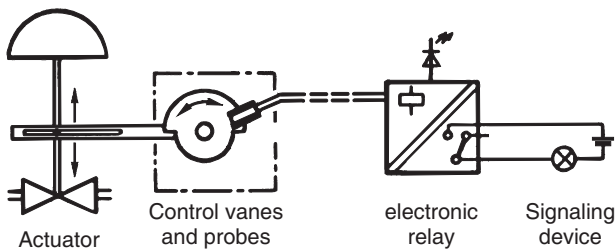

Fig. 41: Functional schematic (acc. to DIN 19324 / NAMUR)

We recommend the following switch amplifiers:

Separating switch amplifier with relay output
 Pepperl+Fuchs GmbH type numbers:
 Normal version WE 77/Ex2
 Safety version WE 77/Ex-SH-03

For further information see above documentation.

7.4 Start-up

The switching functions may be freely selected and set. The control vanes may be adjusted as desired in order to reach the wanted switching behavior. The illustration here shows the four basic settings and adjacent the respective switch behavior (gray=immersed vane).

The examples are based on the following setting: Mounting left = feedback lever right; transmission is selected so that at stroke x from 0 to 100% the guidance shaft travels through a rotary angle of 180°. Illustrated in resting position x = 0%.

2-wire technique: if control vane is immersed the initiator power circuit becomes high-ohmic.

3-wire technique: if control vane is immersed the contact is closed against plus.

Micro switch: Contact opens during passing of the control vanes.

7.2 Electrical connection

Grounding conductor connection following installation in the SRP981 - see page 13.

7.3 Arrangement of connection

The connection cable is guided through the cable gland Pg 13.5 (cable diameter 6...12 mm) and connected to the terminal bar (see page 24).

The terminals are tied up as follows:

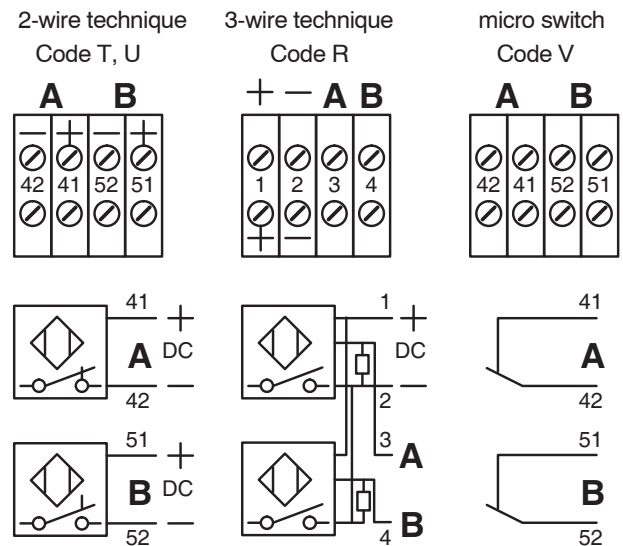

The terminals are suited for cable cross-sections of up to 2.5 mm² (fine-strand).

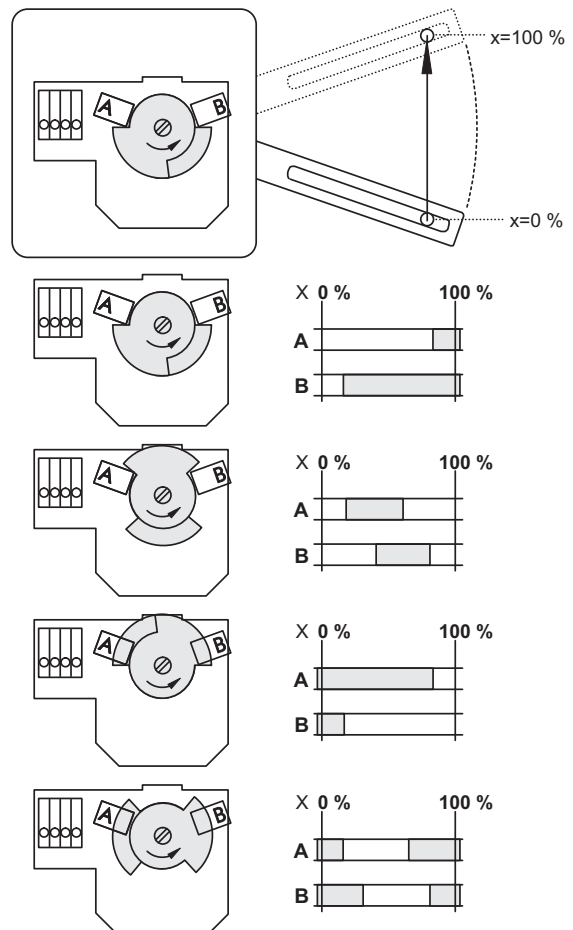

7.5 Setting Limit Values

The switching points are dependent on the setting of the control vanes **83**, on the settings of the probes **A** and **B** and on the ratio setting.

To **set the control vanes** loosen the screw **82** on the drive shaft and align the control vanes in accordance with the illustrations on page 23.

During loosening and/or tightening this screw hold control vanes tightly to avoid damaging pinion and tooth segment.

Adjust the probes as follows:

- a) Move the actuator to the position to be signalled
- b) Loosen locking screw **86** and adjust the switching points by turning adjustment screws **87**.
- c) Then retighten locking screws.

To **set the transformation** the ratio of the rotation angle of the control vanes can be set continuously by turning the spindle screw **85** of the adapter. Turn clockwise to increase the ratio and counter-clockwise to reduce it.

Screw on housing cover with the air vent facing downwards when the device is mounted.

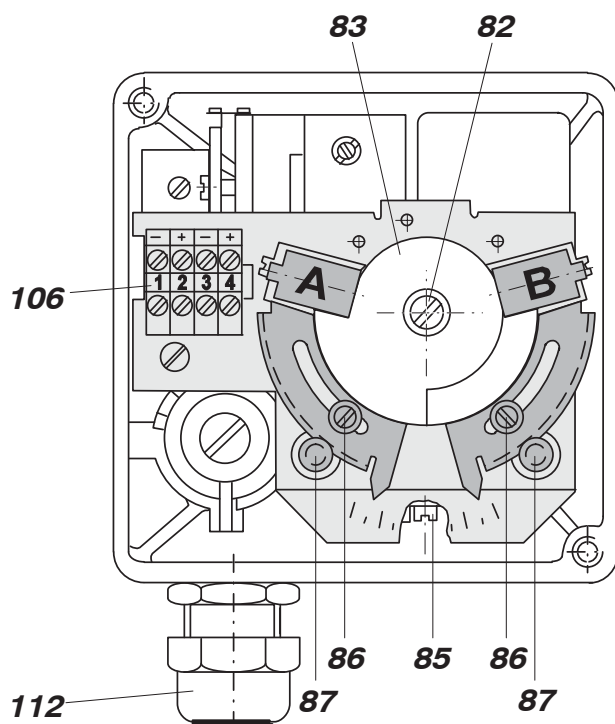

7.6 Maintenance

No maintenance is required.

7.7 Safety requirements

see page 29.

7.8 Subsequent installation or exchange

For subsequent installation there are kits available in appropriate versions - see PSS EVE0101A. Safety requirements indicated on page 29 are to be absolutely observed!

The kit includes the following parts:

- 108** Adapter for transferring the rotary movement to the control vane
- 107** Hexagonal bolts for mounting plate
- 119** Mounting plate with probes, adjusting devices, terminals
- 111** Bolts for housing cover
- 112** Cable gland
- 112a** Screw plug
- 117** Frame with sealing

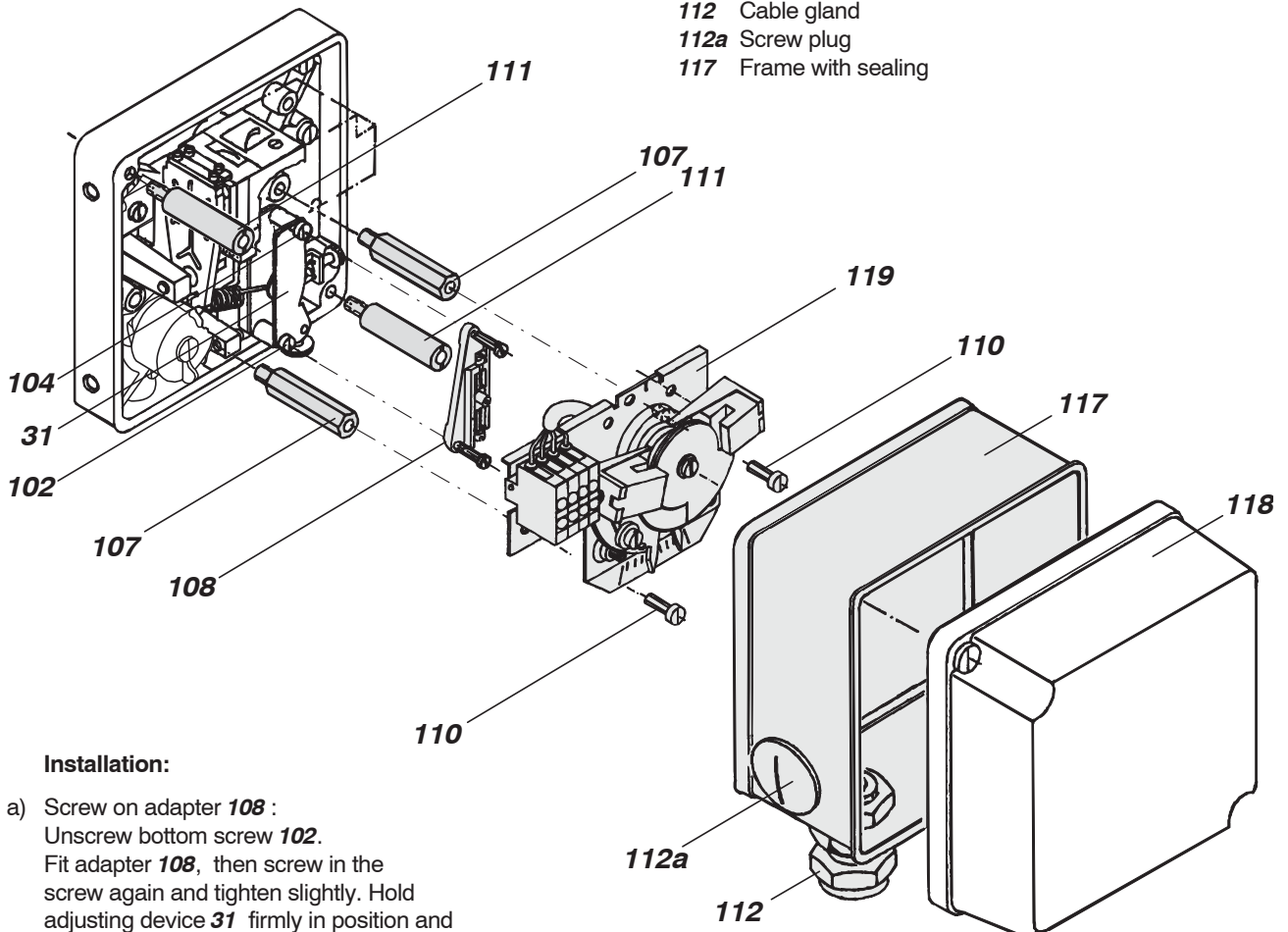

Installation:

- a) Screw on adapter **108** :
Unscrew bottom screw **102**.
Fit adapter **108**, then screw in the screw again and tighten slightly. Hold adjusting device **31** firmly in position and unscrew top screw **104**. Install adapter **108** and tighten the screw again. Tighten screws **102** and **104**.
- b) Insert two hexagonal bolts **107** (8 mm A/F): Release screw **121**, attach gasket to long hexagonal bolt and insert instead of screw **121**.
In case of single-acting positioners release screw **122**, transfer gasket to short hexagonal post and insert instead of screw **122**.
In case of double-acting positioners release screw **123**, transfer gasket to medium length hexagonal post and insert instead of screw **123**.
- c) Screw mounting plate **119** to the two hexagonal bolts **107** with the two screws **110** (if necessary, adjust the adjusting devices so that the right-hand mounting hole is accessible). Be careful to ensure that the driving pin of the adapter engages in the slot in the gear segment.
- d) Screw the two bolts **111** into the female threads to secure the housing cover. When the positioner is installed, these will be the female threads in the top left-hand corner and in the bottom right-hand corner.
- e) Secure cable gland **112** and screw plug **112a** to frame **117** with the enclosed nuts.
Fit the frame with the rubber seal facing the positioner and cable gland **112** at the terminals.
- f) Screw on the housing cover with the air vent facing downwards when the device is mounted.

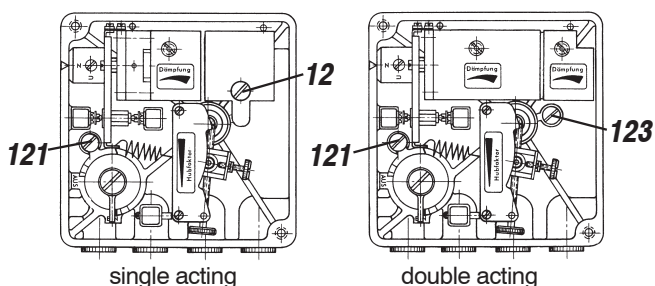

8 Option “El. Position Transmitter”

The electrical position transmitter is additional equipment either installed in the factory or up-dated. It converts the stroke or rotary movement of an actuator into an electrical standard signal 4...20 mA.

8.1 Function

The stroke or rotary angle of an actuator are transmitted to the position controller with a built-in electrical position converter via control lever. The angle setting is converted proportionately into a voltage with a potentiometer. This voltage is then converted into the electric standard signal 4 ... 20 mA. Adaption to the stroke of the actuator takes place internally. The start and end of the measuring range are set with trim potentiometers.

8.2 Electrical Connections

Grounding cable connection following installation in the SRP981 - see page 13.

8.3 Arrangement of connection

The cable is inserted through the Pg 13.5 cable gland **112** (suitable for lead diameters 6...12 mm) and is connected at the terminal block **106** .

The terminals are suitable for wire cross-sections of up to 2.5 mm².

Cable gland **112** and screw plug **112a** are interchangeable.

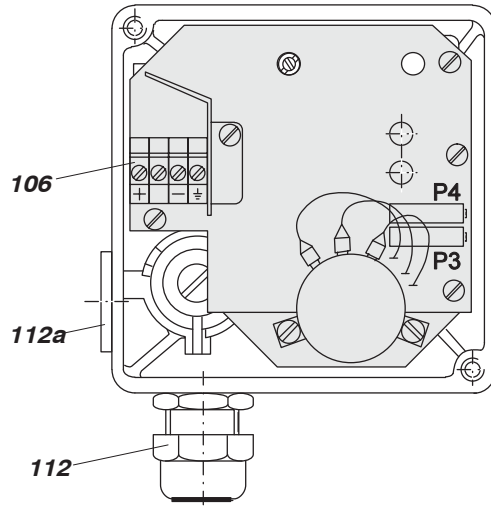

The terminals are connected as follows:

- K1 Auxiliary energy (+)
- K2 Uninterrupted signal current measurement with a low resistance ampmeter ($R_i \leq 10 \text{ Ohm}$)
- K3 Auxiliary energy (-)
- K4 Protective earth connection

The power supply ($U_s = \text{DC } 12...36 \text{ V}$) originates from the signal circuit in two wire connection.

The maximum permissible load impedance R_{Bmax} is calculated with the following equation:

$$R_{Bmax} = (U_s - 12 \text{ V}) / 0.02 \text{ A} \quad [\text{Ohm}]$$

$U_s = \text{Supply voltage in V}$

8.4 Maintenance

No maintenance is required.

8.5 Start-up (continued on next page)

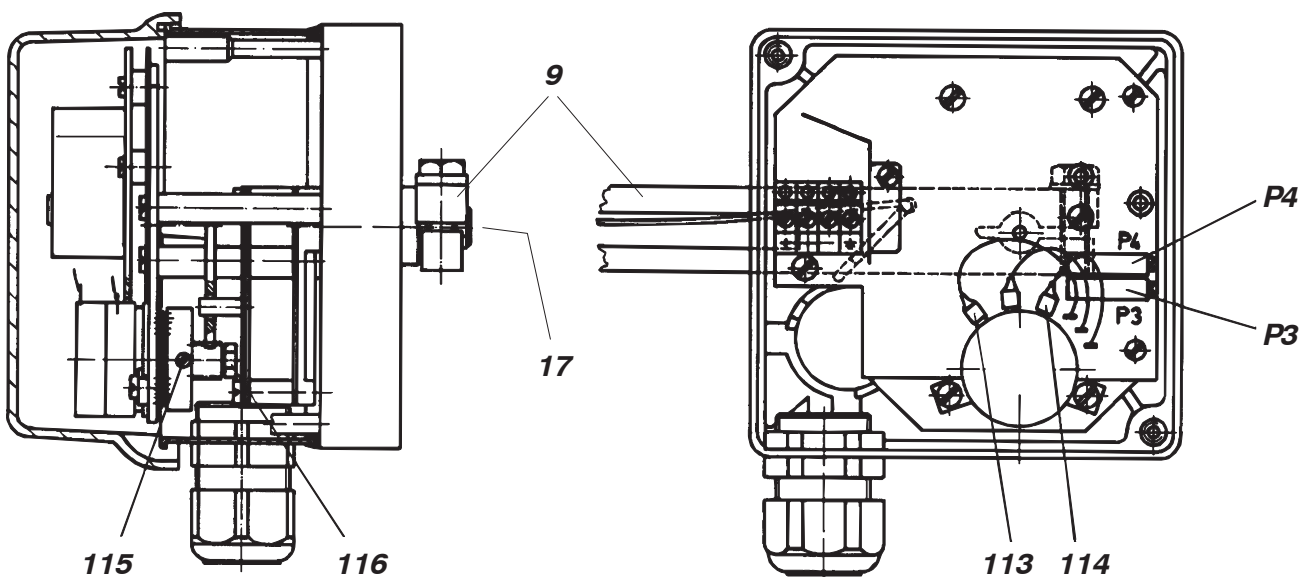

Fig. 49: Adjusting the start and end of the measuring range

8.5 Adjusting the measuring range

Start of measuring range

Bring the actuator to the starting position. With potentiometer **P4**, adjust the measuring range start 4 mA.

End of measuring range

Bring the actuator to the end position and set potentiometer **P3** to the measuring range end value 20 mA.

If you wish to make a greater adjustment to **P3**, check the setting of **P4** again and correct if necessary. Next adjust **P3** again.

Adjusting the mechanical zero

(Only necessary if adjustment is not possible as described above.)

Turn potentiometer **P4** counterclockwise to the lowest value and set potentiometer **P3** to the highest value.

Bring the actuator to the starting position.

Undo screw **115**. Set the mechanical zero point by turning the hexagon screw **116** with a set spanner A/F 4 to a starting value of between 3.5 and 3.8 mA.

Tighten screw **115** again.

Adjust start and end of measuring range as described above.

8.6 Conversion from normal direction of action in reverse direction of action

Set potentiometer **P4** to the lowest value by turning it counterclockwise and set potentiometer **P3** to the maximum value.

Swap around connections **113** and **114**.

Start of measuring range

Bring the actuator to its end position.

Undo screw **115**. Set the mechanical zero point to a starting value of between 3.5 and 3.8 mA by turning the hexagon screw **116** with a set spanner A/F 4.

Tighten screw **115** again.

With potentiometer **P4**, adjust the measuring range start 4 mA.

End of measuring range

Bring the actuator to the starting position.

Set potentiometer **P3** to the measuring range end value 20 mA.

In the event of a greater adjustment to **P3**, check the setting of **P4** again and correct it if necessary, then check the setting of **P3** again.

Important in the case of Ex version:

The conversion from "normal" to "reverse" must be certified by a recognized expert or carried out by the manufacturer.

Attachment side, left:

rising output signal with retracting drive spindle.

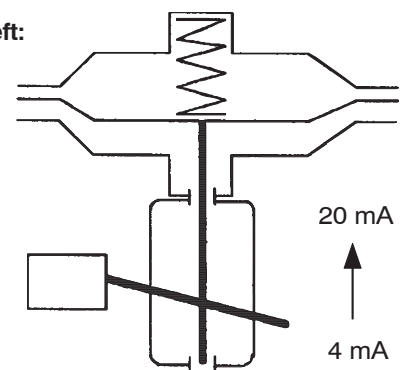

Attachment side, right:

rising output signal with extending drive spindle.

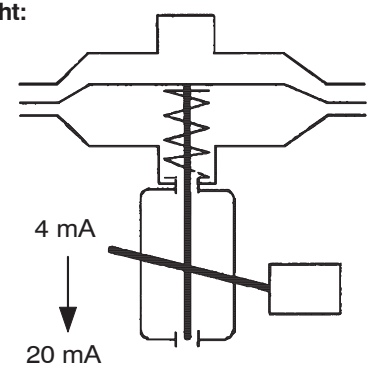

Attachment side, left:

Falling output signal with retracting drive spindle.

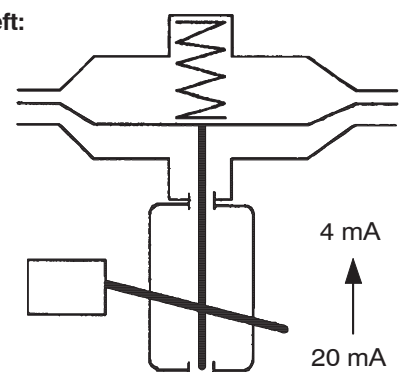

Attachment side, right:

Falling output signal with extending drive spindle.

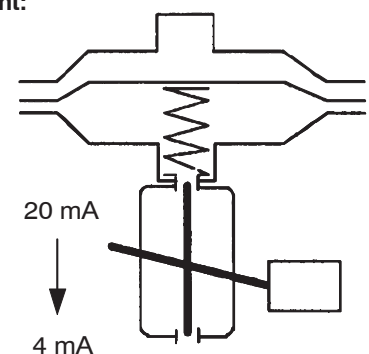

8.7 Subsequent installation or exchange

For subsequent installation there are kits available, see PSS EVE0101A. Safety requirements indicated in page 29 are to be absolutely observed!

Kit components:

- 101** Driver plate for transmitting the rotary motion
- 105** Support Ø 7 mm for converter plate
- 109** Converter plate with 2 fillister head screws **110** and one lock washer **120**
- 111** Support for cover
- 112** Cable screw connection
- 112a** Screw plug
- 117** Frame with rubber seal

Adjusting the measuring ranges (see Fig. 49)

- Bring actuator to starting position.
- Connect control lever **9** non-positively with position controller shaft **17**.
- Unscrew cover **118** and frame **117**.
Turn potentiometer **P4** counterclockwise to the lowest value and set potentiometer **P3** to the maximum value.
- Remove screw **115**.
Set the mechanical zero point to a starting value of between 3.5 and 3.8 mA by turning the hexagon screw **116** with an open-end spanner A/F 4.
- Re-tighten screw **115**.

Adjusting the start and end of measuring range see page 27.

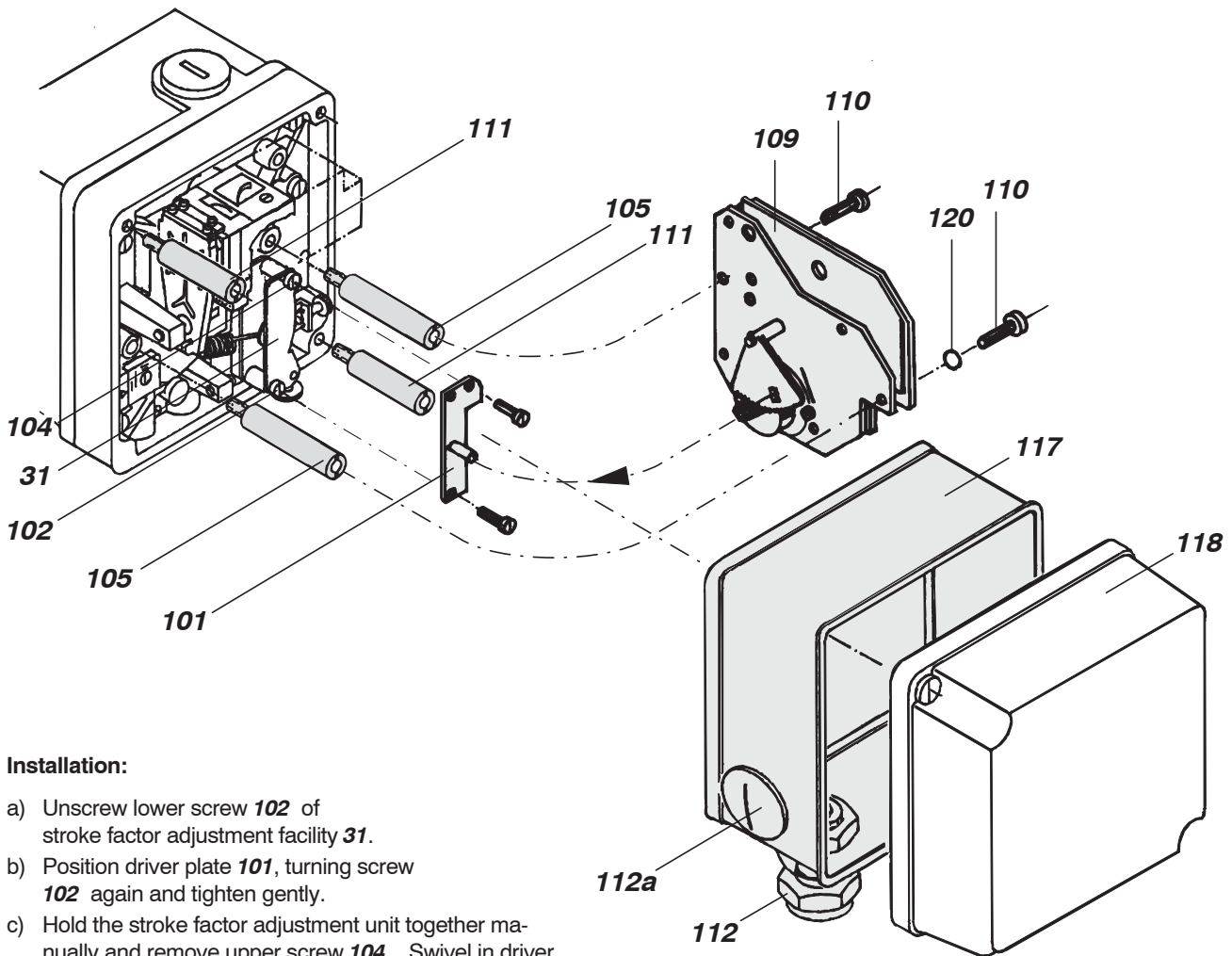

Installation:

- a) Unscrew lower screw **102** of stroke factor adjustment facility **31**.
- b) Position driver plate **101**, turning screw **102** again and tighten gently.
- c) Hold the stroke factor adjustment unit together manually and remove upper screw **104**. Swivel in driver plate and return screw. Tighten screws **102** and **104**.
- d) Screw in the 2 supports **105** Ø 7 mm as follows: Longer support left, shorter support right.
- e) Secure converter plate **109** with screws **110** and a lockwasher **120** (left screw) to the two supports so that the pin on the driver plate **101** engages into the slot on the tooth segment.
- f) Screw two supports **111** into the female thread for securing the cover. In installation position, these are the female threads in the top left corner and in the bottom right corner.
- g) Secure cable screw connection **112** and screw plug **112a** to frame **117** using the nuts supplied. Position the frame so that the rubber seal faces towards the position controller and so that the cable screw connection **112** is next to the terminals.
- h) Screw on cover **118** so that the ventilation slot is at the **bottom** when the unit is attached.

9 SAFETY REQUIREMENTS

9.1 Accident prevention

This device complies with the regulations for the prevention of accidents **Power-Driven Work Aids (VBG 5)** of 1st October 1985.

9.2 Electrical safety

9.2.1 General requirements

This device with the equipment **Inductive limit switches**, Model Code R, T, U or **Position transmitter 4-20 mA**, Model Code W satisfies the conditions for safety class III according to EN 61010-1 (IEC 1010-1).

With the equipment **Two micro switches**, Model Code V it satisfies the conditions for safety class II, pollution degree 2, overvoltage category II according to EN 61010-1 (IEC 1010-1).

Any work on electrical parts must be done by qualified personnel if any power supply is connected to the instrument.

9.2.2 Connection requirements

The device has to be used for its designated purpose, it has to be connected in accordance with the electrical connection (see page 13). The national requirements need to be considered (for Germany DIN VDE 0100 and DIN VDE 0800).

The device has to be operated with safety extra-low voltage SELV or SELV-E.

Internal safety precautions may be rendered ineffectual if the instrument is not operated in accordance with the Master Instruction.

Limitation of power supplies for fire protection have to be observed due to EN 61010-1, appendix F (resp. IEC 1010-1).

Devices with position transmitter 4 ... 20 mA: For electromagnetic compatibility EMV, the ground connection must be made (CE).

9.2.3 Explosion protection

Only if ordered accordingly, with **Inductive limit switches**, Model Code T or U or with **Position transmitter 4-20 mA**, Model Code W,

Technical data for explosion protection see Product Specification PSS EVE0101 A.

For installations in contact with explosive atmospheres, all relevant national regulations and installation conditions must be observed, e. g. in the Federal Republic of Germany ElexV and DIN VDE 0165.

Attention:

When repairing explosion-proof equipment, observe the national regulations.

Use only original spare parts when making repairs.

The following applies to the Federal Republic of Germany: Repairs involving parts required for explosion protection must either be carried out by the manufacturer or by authorized personnel and confirmed by certificate.

9.2.4 EMC and CE

Remarks according Electromagnetic compatibility EMC and CE marking see Product Specification PSS EVE0101 A.

10 TROUBLE SHOOTING

| Fault | Possible cause | Remedy |
|---|--|--|
| Actuator does not react to the applied input signal nor to a change in the input signal | pneumatic connections switched | check connections |
| | feedback lever loose | tighten feedback lever (see 2.2.3) |
| | positioner mounted on the wrong side | check mounting side with the table in chapter 2.2.2 |
| | changeover plate in the wrong position | check position with table in section 2.2.2 |
| | amplifier defective | change amplifier (see 6.1) |
| Output pressure does not attain the full value | supply pressure too low | check supply air |
| | flappers not parallel to nozzles | align flappers (see 5.1 d, e or 5.2 d, e) |
| | pre-throttle in amplifier blocked | clean pre-throttle (see 5.3) |
| | filter in supply connection blocked | change filter |
| Actuator runs to the end position | positioner mounted on the wrong side | check mounting side with table in chapter 2.2.2 |
| | feedback lever loose | tighten feedback lever (see 2.2.3) |
| | pneumatic connections switched (double-acting version) | check connections (see 2.2.2 and 2.2.3) |
| Unstable behaviour - positioner circuit oscillates | amplification too high | reduce amplification (see 4.1) |
| | gland friction on valve too great | loosen gland slightly or renew |
| | for piston actuators: static friction on cylinder too great | reduce amplification (see 4.1) |
| | Stroke range cannot be set | range spring unsuitable |
| Stroke range cannot be set | positioner does not exhaust pressure completely | check supply air (max. 6 bar) |
| | | check amplification (see 4.1) |
| | | adjust distance between nozzle and flapper (see 5.1 e, f and 5.2 e, f) |

Detail: Nozzles / flappers system

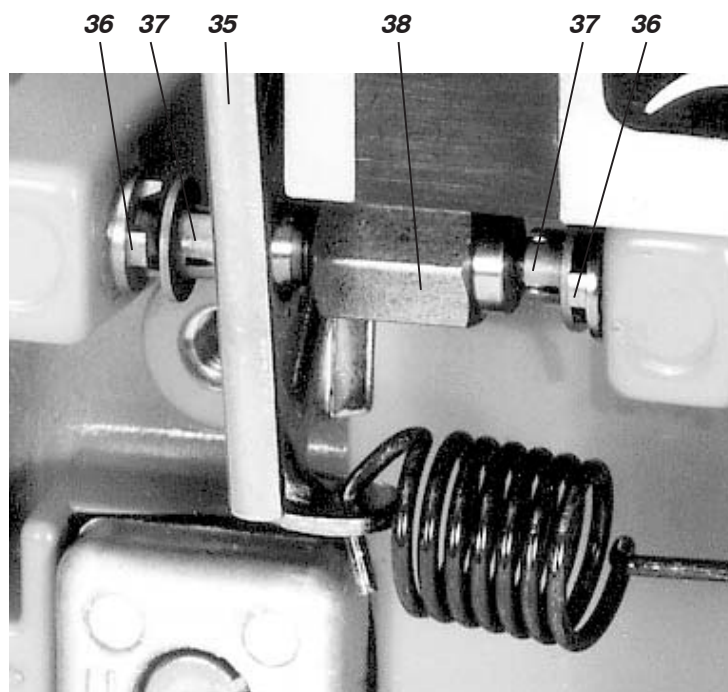

Single acting positioner SRP981

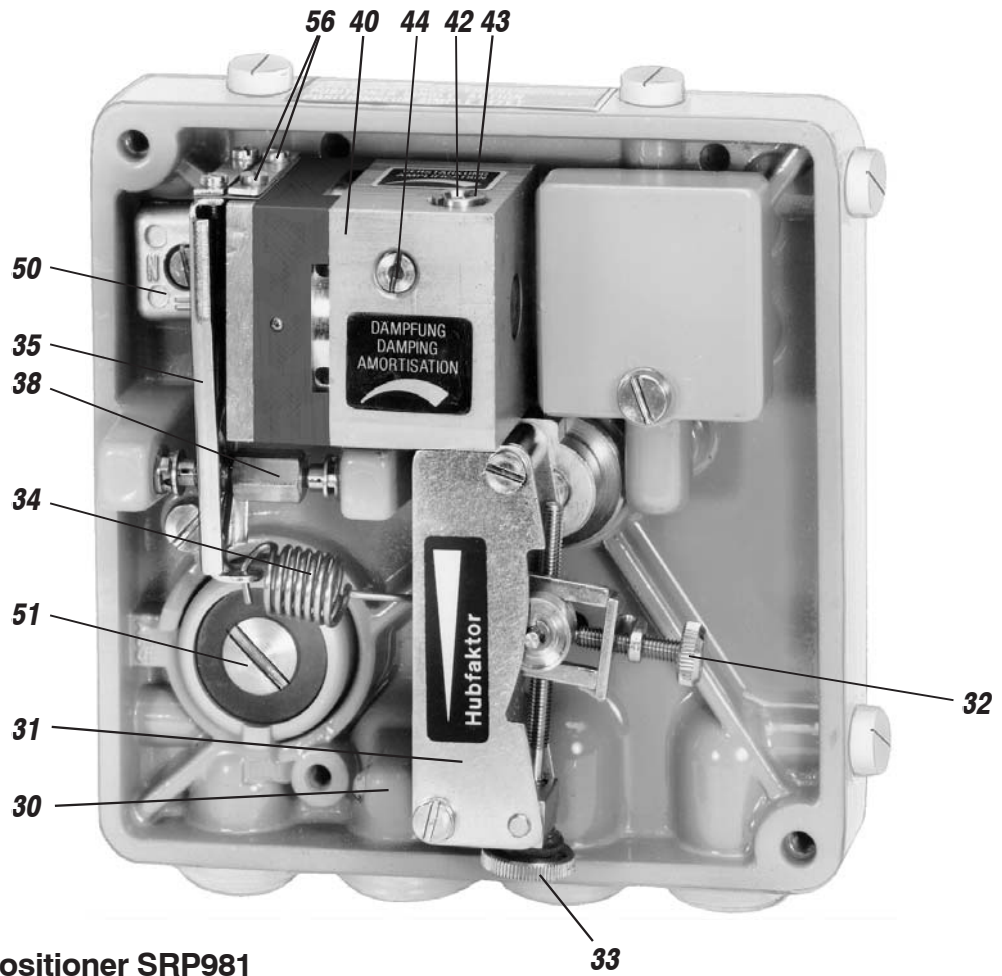

Double acting positioner SRP981

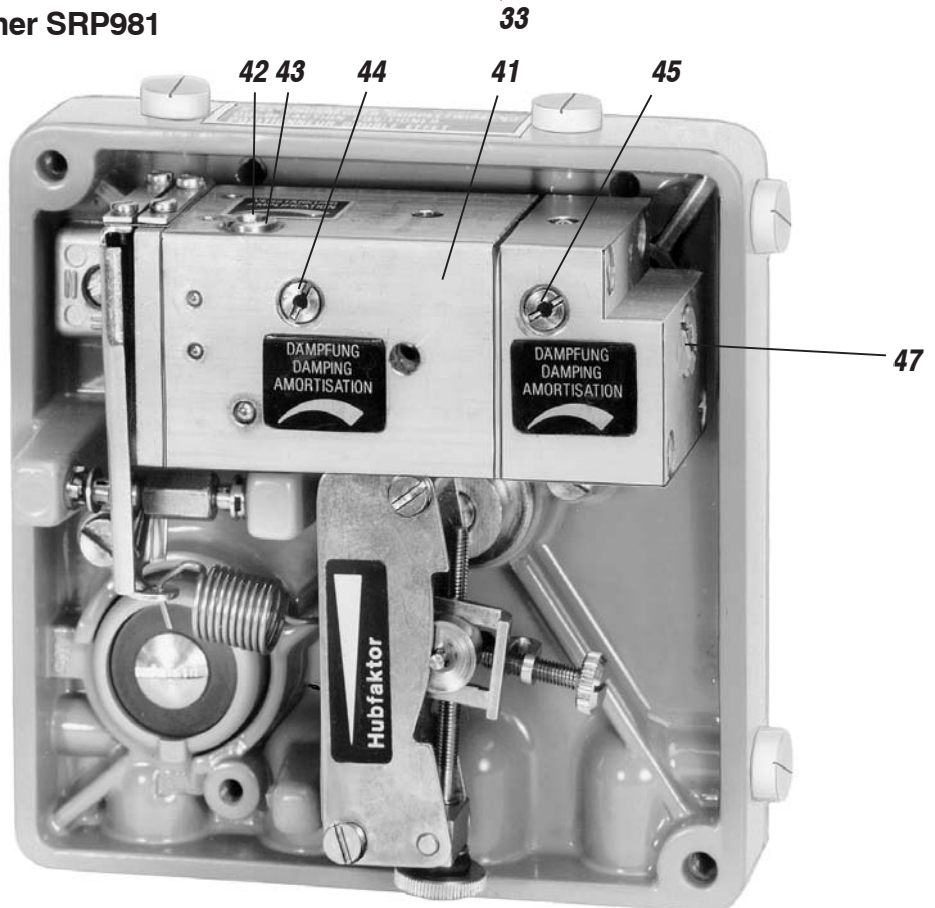

Subject to alterations - reprinting, copying and translation prohibited. Products and publications are normally quoted here without reference to existing patents, registered utility models or trademarks. The lack of any such reference does not justify the assumption that a product or symbol is free.

FOXBORO ECKARDT GmbH
Postfach 50 03 47
D-70333 Stuttgart
Tel. # 49(0)711 502-0
Fax # 49(0)711 502-597

DOKT 535 781 027