

**SRI990      Analog Positioner**  
**SRI990-T    Electrical Position Transmitter**

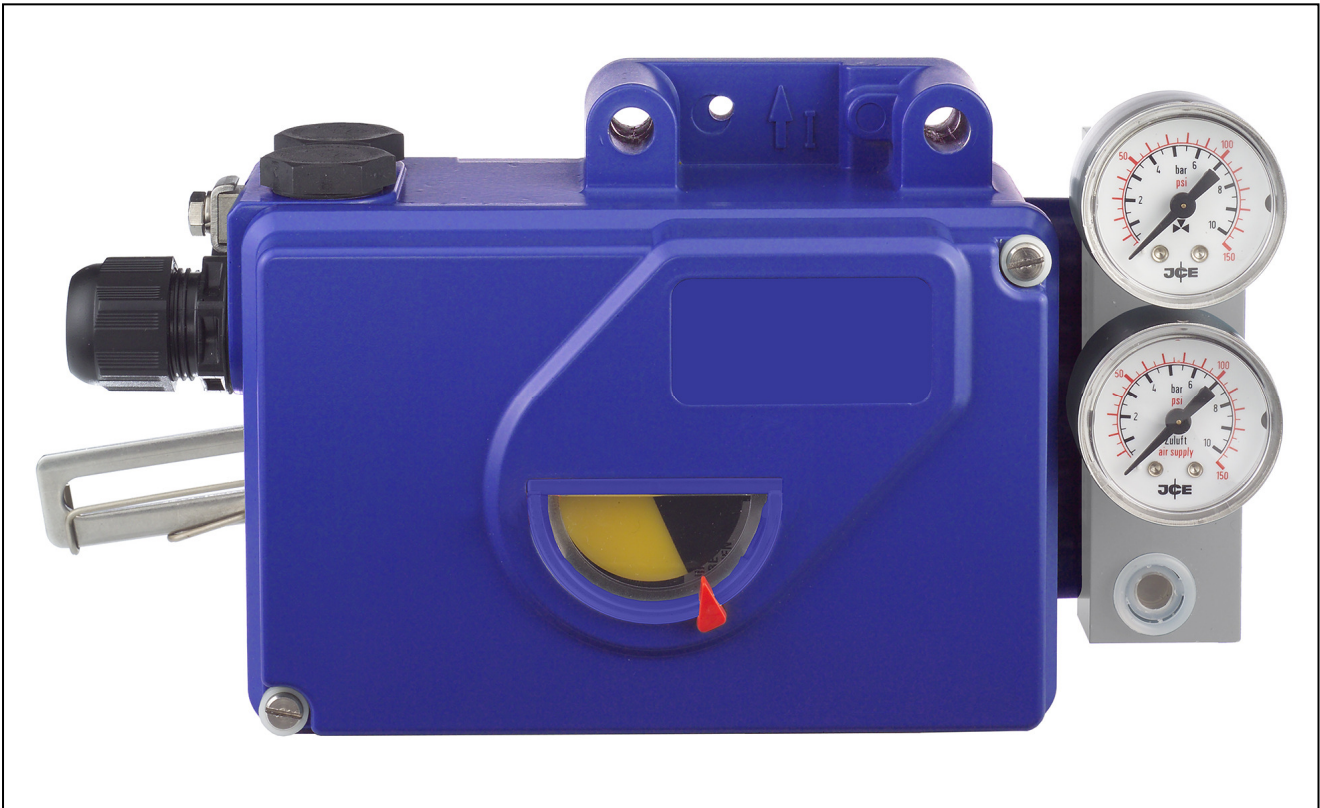

The analog Positioner **SRI990** with analog input 4 to 20 mA is designed to operate pneumatic valve actuators. It offers an easy adjustment by means of switches and potentiometers. The modular structure of this positioner series enables conversion from an analog to an “intelligent” positioner by easy exchanging the electronics. In version “Electrical Position Transmitter” **SRI990-T**, the device includes the option Position Transmitter, but no controller and no pneumatic components. The position of actuator / valve is given as a 4 - 20 mA output signal. Further versions see next page.

**FEATURES**

- Configuration by means of switches and potentiometers
  - Load 300 Ω
  - Low air consumption
  - Stroke 8 to 260 mm (0.3 to 10.2 inch)
  - Angle range up to 95 degree
  - Supply air pressure up to 6 bar (90 psig), with spool valve up to 7 bar (105 psig)
  - Single acting or double acting
  - Mechanical travel indicator
  - Position transmitter 4 - 20 mA as option
  - Attachment to stroke actuators directly or according to IEC 534 part 6 (NAMUR)
  - Attachment to rotary actuators according to VDI/VDE 3845
  - Protection class IP 66 and NEMA 4X
  - Explosion protection: II 2 G Ex ib/ia IIB/IIC T4/T6 according to ATEX or “Intrinsic Safety” according to CU TR
- Additional equipments (compatible to SRD991):
- Integrated inductive limit switches, independent of device electronics
- Accessories (compatible to SRD991):
- Gauge attachment for supply air and outputs
  - Booster relay
  - SRI990 can be upgraded to a SRD991 by exchange of the electronic motherboard

*Equipment should be installed, operated, serviced, and maintained only by qualified personnel.  
No responsibility is assumed by Schneider Electric for any consequences arising from the use of this material.*

## TABLE OF CONTENTS

CHAP: CONTENT	PAGE	CHAP: CONTENT	PAGE
1	METHOD OF OPERATION.....	3	
1.1	General .....	3	
1.2	Block diagram .....	3	
1.3	Operation .....	3	
1.4	Safety Requirements.....	4	
2	LABELS .....	5	
3	DESIGN .....	6	
3.1	Pneumatic accessories .....	7	
4	MOUNTING TO LINEAR ACTUATORS .....	8	
4.1	NAMUR Mounting (left hand).....	8	
4.2	NAMUR Mounting (right hand) .....	10	
4.3	Direct Mounting.....	12	
5	MOUNTING TO ROTARY ACTUATORS .....	14	
6	PNEUMATIC CONNECTIONS .....	16	
7	ELECTRICAL CONNECTION.....	17	
8	START-UP .....	18	
8.1	General .....	18	
	Setting of -		
8.2	- Direction of rotation of feedback shaft.....	19	
8.3	- Input Signal Range.....	20	
	- Split Range .....	20	
8.4	- Gain (G) .....	21	
8.5	- Zero (ZERO) and Span (S).....	21	
8.6	- Damping (D) .....	21	
8.7	- Travel indicator .....	21	
8.8	Start-up of Position Transmitter (4-20 mA) for transmitter SRI990-xIQxxx.....	22	
8.9	Basic adjustment of electronics .....	22	
8.10	Pneumatic test .....	22	
9	DECOMMISSIONING.....	23	
10	Diagnosis .....	23	
11	MAINTENANCE .....	24	
11.1	General .....	24	
11.2	Supply filter replacement.....	24	
11.3	Removal of the electronics unit.....	24	
11.3.1	Conversion of positioner .....	24	
11.4	Replacement of mechanical and pneumatic units .....	25	
11.4.1	Amplifier replacement .....	25	
11.4.2	Preamplifier replacement .....	25	
11.4.3	IP-module replacement.....	25	
11.4.4	Feedback unit replacement .....	25	
12	OPTION "Limit switch" .....	26	
13	SYSTEM CONFIGURATION .....	27	
	DIMENSIONS.....	28	

## 1 METHOD OF OPERATION

### 1.1 General

The intelligent positioner SRI990 **1** and the pneumatic actuator **2** form a control loop with the set point value  $w$  (from master controller or control system), the output pressure  $y$  and the position  $x$  of the actuator on valve **3**.

The positioner can be attached to both linear actuators and rotary actuators.

The positioner is operated by means of switches and potentiometers.

Actuators with spring force are controlled by a single acting positioner. Actuators without a spring force are controlled by a double acting positioner.

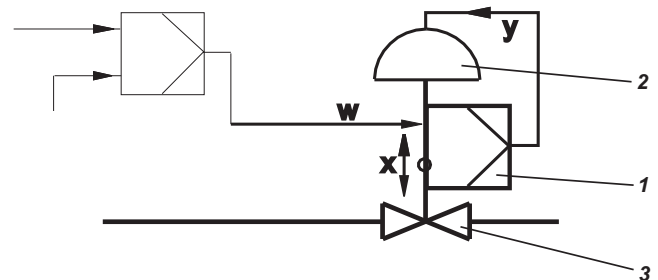

For the supply air, we recommend the FRS02 filter regulator.

### 1.2 Block diagram

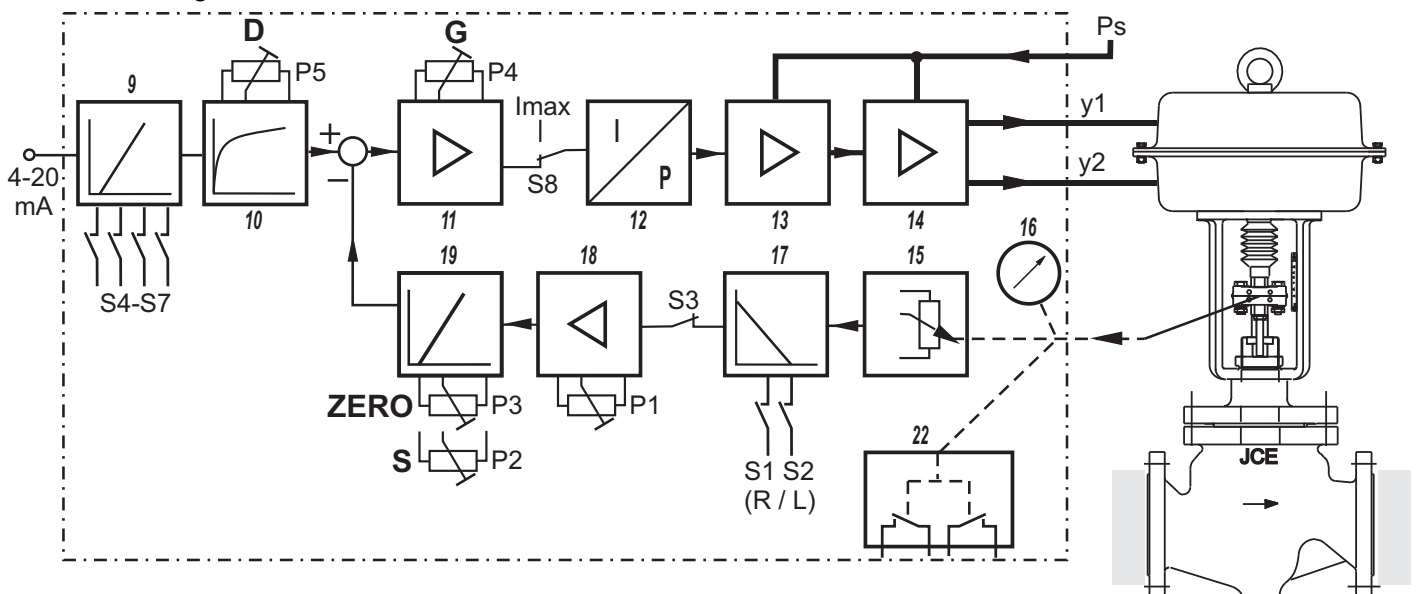

### 1.3 Operation

The supply of the electronics unit is diverted from the current signal 4 to 20 mA at the input.

The current value is measured and is suited in input circuit **9** to the desired input range (control action or split range) via switches S4 - S7. In circuit **10** the signal is provided with an adjustable time constant settable via potentiometer P5.

The resulting internal signal is guided to the analog control circuit **11**, the gain of which is adjustable via potentiometer P4. The output of the control circuit drives the electro-mechanic converter (IP module) **12**, which controls the analog single acting or double acting pneumatic amplifier **14** through the preamplifier **13**. The output of the amplifier **14** is the output pressure  $y$  ( $y_1$ ,  $y_2$ ) to the actuator. The pneumatic amplifiers are supplied with supply air  $P_s$  1.4 to 6 bar (20 to 90 psig).

The position  $x$  of the actuator is measured by the position sensor (conductive plastic potentiometer) **15**. The desired direction of rotation is set in **17** via switches S1 and S2. The SPAN is suited to the stroke / rotation angle range via potentiometer P2, while ZERO is set in **19** via potentiometer P3. With switch S3, potentiometer P1 provides an internal zero adjustment in **18**, carried out by the manufacturer (service function). The resulting feedback signal is guided to control circuit **11**.

The IP module receives its maximum drive current via switch S8, enabling checking of the function of the pneumatic unit.

The position  $x$  of the actuator is independently displayed by the mechanical travel indicator **16**.

The mechanical limit switch **22** (optional) enables independent alarm signals.

## 1.4 Safety requirements

### Accident prevention

This device complies with regulations for the prevention of accidents Power-Driven Work Aids (VGB 5) of 1st October 1985.

In option "limit switch" do not touch control vane during operation - danger of injuries!

### Electrical safety

This instrument satisfies the conditions for safety class III, overvoltage category I acc. to EN 61010-1 or IEC1010-1.

Any work on electrical parts must be done by qualified personnel.

The instrument must be used for its designated purpose and connected in accordance with its connection diagram (see pages 17 and 27).

Locally applicable installation regulations for electrical equipment must be observed, e.g. in the Federal Republic of Germany DIN VDE 0100 resp. DIN VDE 0800.

The instrument contains no built-in fuses.

The instrument must be operated with safe, extra low voltage SELV or SELV-E.

Safety precautions taken with the instrument may be rendered ineffective if the instrument is not operated in accordance with the Master Instructions.

Limitation of power supplies for fire protection must be observed in accordance with EN 61010-1, appendix F or IEC 1010-1.

### Explosion protection

(Only if ordered)

Technical data for explosion protection see Product Specifications Sheet PSS EVE0107 A-(en).

For installations located in explosive atmospheres, all relevant national regulations and installation conditions must be observed, e.g. in the Federal Republic of Germany ExeV and DIN VDE 0165.

Attention:

When repairing explosion-protected equipment, observe the national regulations.

Repairs involving parts must be manufacturer's original parts.

The following applies to the Federal Republic of Germany: Repairs involving parts required for explosion protection must either be carried out by the manufacturer or by authorized personnel and confirmed by certificate.

### EMC and CE

For notes regarding Electromagnetic compatibility EMC and CE labels see Product Specifications Sheet PSS EVE0107 A.

In order to ensure EMC protection, the electronic board must be screwed to the housing.

**2 LABELS**

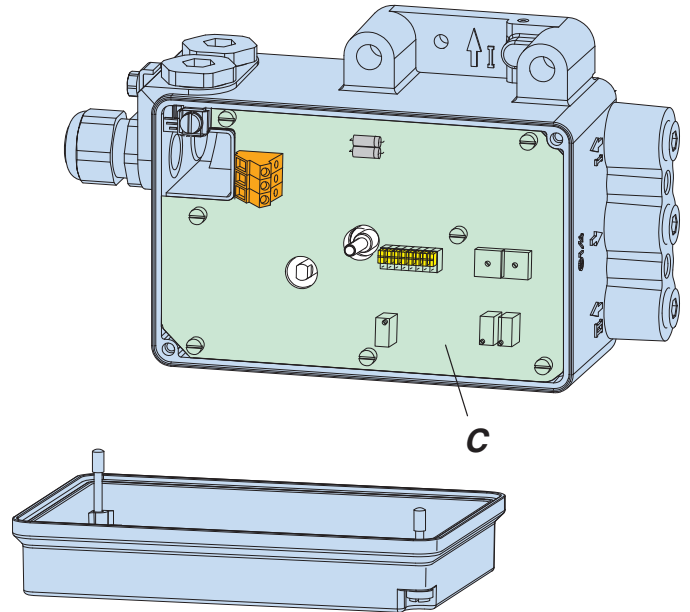
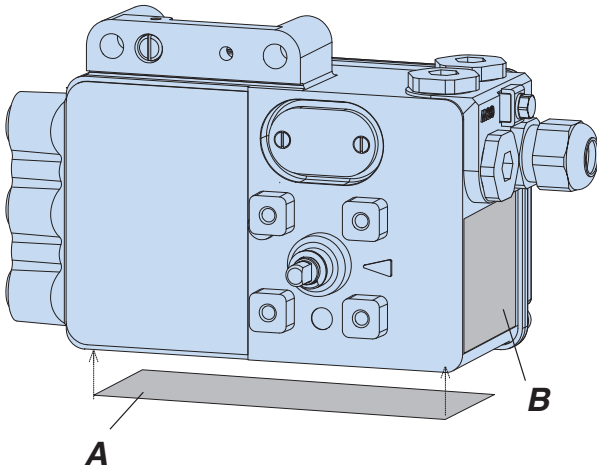

- A** Nameplate
- B** Additional label for options
- C** Imprinted references regarding settings

**Nameplate A (Example)**  
Without Ex-protection

<b>ECKARDT SAS</b>		REV. <b>1.3</b>
<b>SRI990-BIQS7ZZZ</b>		ZUSÄTZLICHE EIN- / AUSGÄNGE ADDITIONAL INPUTS / OUTPUTS
FABR. No SER. No <b>38 / 005729</b>		STELL. UMFORMER POS. TRANSMITTER
ZULUFT / SUPPLY : max. <input type="checkbox"/> 6 / 90 bar / psi		STELLUMF POS.XMTR KLEMME TERMINAL
<input checked="" type="checkbox"/> EINFACH / SINGLE <input type="checkbox"/> DOPPELT / DOUBLE		
EINGANG / INPUT 4...20mA		31 32
		Uop = 12...32V
Tu -40°C ... +80°C		(3)

- SRI990 [ Device specification, Model Code ]
- SER.No [ Serial number ]
- ECEP [ Number for special engineered version ]

**Measurement point label (Example)**  
Directly fixed or attached

○	XXX 7154 / 8085 / 1
---	---------------------

**Nameplate A (Example)**  
Classified intr. safe by ATEX  
Type of protection "Ex ia"

<b>ECKARDT SAS</b>		REV. <b>1.3</b>
<b>SRI990-BIQS7EAA</b>		ZUSÄTZLICHE EIN- / AUSGÄNGE ADDITIONAL INPUTS / OUTPUTS
FABR. No SER. No <b>38 / 005729</b>		STELL. UMFORMER POS. TRANSMITTER
ZULUFT / SUPPLY : max. <input type="checkbox"/> 6 / 90 bar / psi		STELLUMF POS.XMTR KLEMME TERMINAL
<input checked="" type="checkbox"/> EINFACH / SINGLE <input type="checkbox"/> DOPPELT / DOUBLE		
EINGANG / INPUT 4...20mA		31 32
		Uop = 12...32V
PTB 02 ATEX 2206 TYPE A I 636 II 2 G EEx ia/ib IIB / IIC T4 / T6 U <sub>i</sub> I <sub>i</sub> P <sub>i</sub> C <sub>i</sub> L <sub>i</sub> Tu <sub>min.</sub> Tu <sub>max.</sub> siehe Betriebsanleitung/see Instruction Manual		(4)

**Additional label B option "Limit switches" (Example)**

ZUSÄTZLICHE EIN- / AUSGÄNGE ADDITIONAL INPUTS / OUTPUTS ENTREES / SORTIES ADDITIONNELLES							
	ModelCode: x x x U x x GRENZWERTGEBER (INDUKTIVE KONTAKTE) LIMIT SWITCH (INDUCTIVE CONTACTS) VALEURS LIMITES (CAPTEURS INDUCTIFS) SICHERHEITS- AUSFÜHRUNG SECURITY-VERSION VERSION SECURITE <table style="margin-left: auto; margin-right: auto;"> <tr> <td>LS1</td> <td>LS2</td> </tr> <tr> <td>VL1</td> <td>VL2</td> </tr> <tr> <td>41 42</td> <td>51 52</td> </tr> </table>	LS1	LS2	VL1	VL2	41 42	51 52
LS1	LS2						
VL1	VL2						
41 42	51 52						
556729108 (2)							

### 3 DESIGN

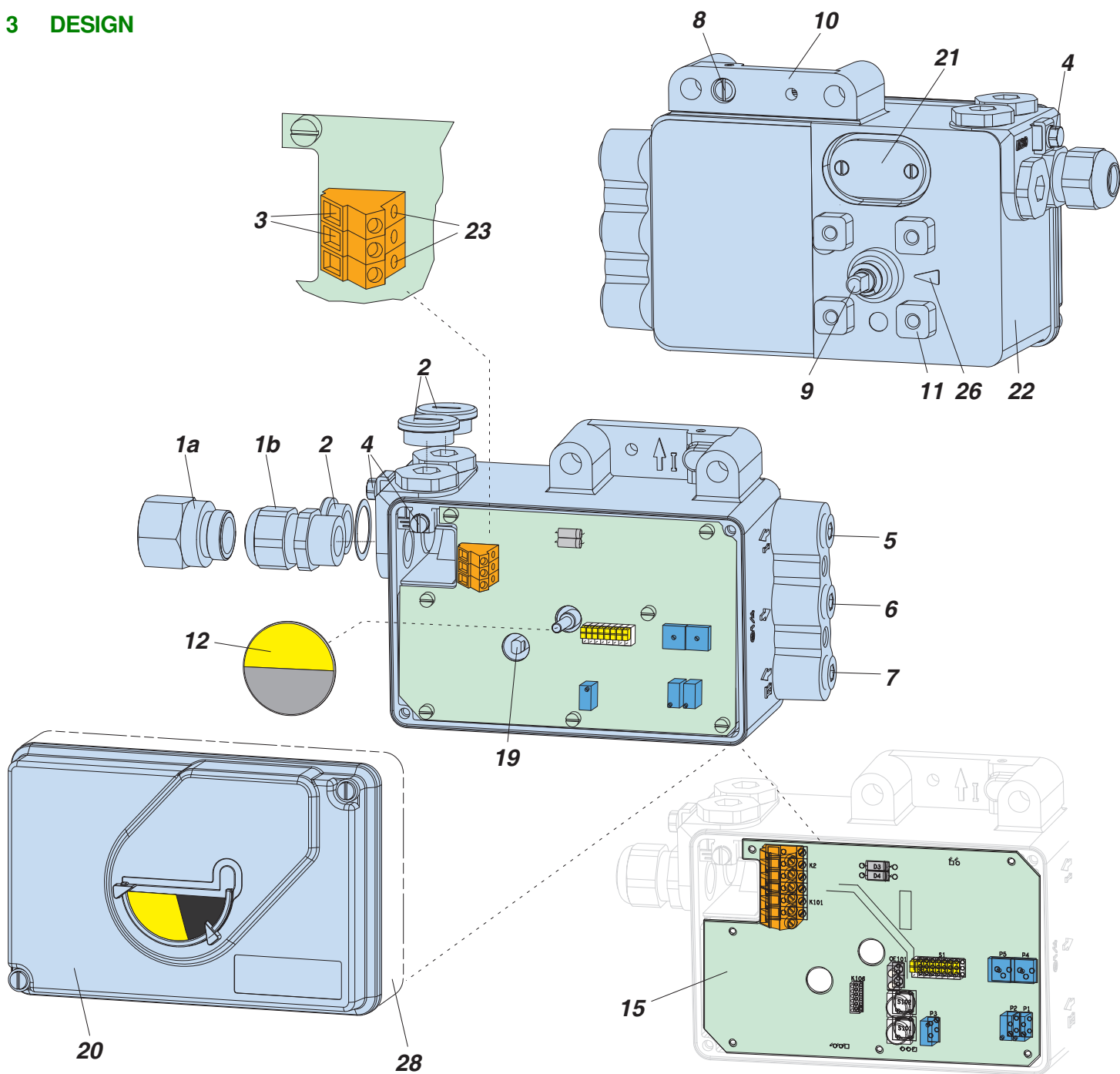

- 1a** Adapter, e.g. 1/2"-14 NPT
- 1b** Cable gland
- 2** Plug, interchangeable with Pos. **1**
- 3** Screw terminals (11 + / 12 -) for input (w)  
- for current measurement (see also Pos. **23**)
- 4** Ground connection
- 5** Female threads G 1/4 for output I (y / y1)
- 6** Female threads G 1/4 for air supply (s)
- 7** Female threads G 1/4 for output II (y2)
- 8** Direct attachment hole for output I (y1)
- 9** Feedback shaft
- 10** Connection manifold for attachment to stroke actuators

- 11** Connection base for attachment to rotary actuators
- 12** Travel indicator
- 15** Main board version "with Position Feedback"
- 19** Fixing shaft for limit switch
- 20** Cover with window to Pos. **12**
- 21** Air vent, dust and water protected
- 22** Data label
- 23** Tip jacks for current measurement, dia. 2 mm  
(integrated in terminals)
- 26** Arrow is perpendicular to shaft 9 at angle 0 degree
- 28** High cover with built-in limit switches, position feedback,  
or Electrical Certification code EDA (Dust)



3.1 Pneumatic Accessories

When mounting, check the proper seating of the O-rings and bolt on the accessories with the two M8 bolts. Unused outputs are closed by means of plastic plugs.

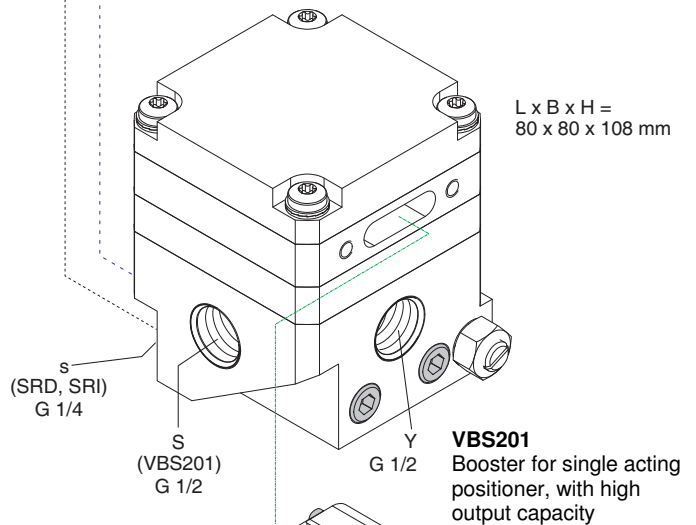
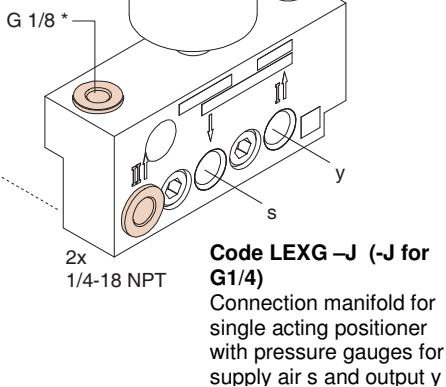
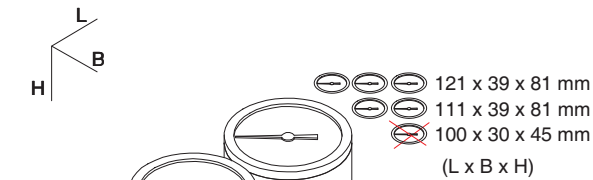
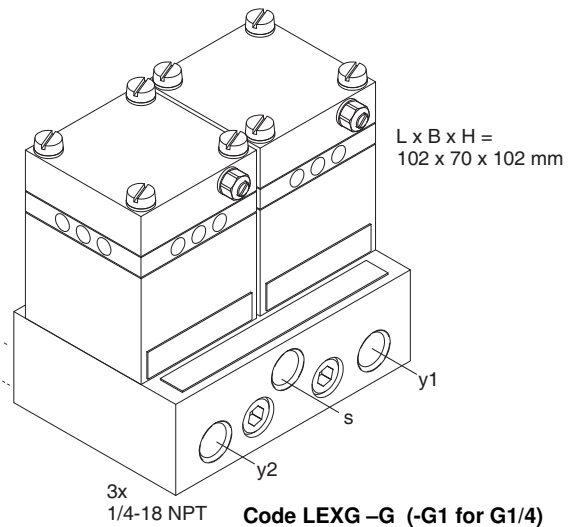
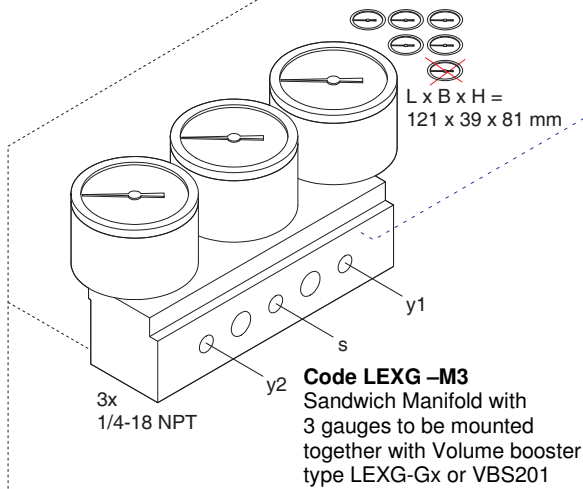
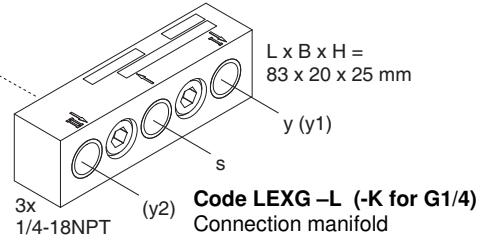
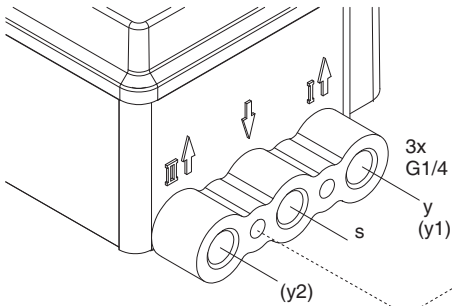

**Code LEXG -M (-M for G1/4)**  
Connection manifold for double acting positioner with pressure gauges for supply air s and output y1 and y2

**Code LEXG -N (-N for G1/4)**  
as -M, M1, but without pressure gauges

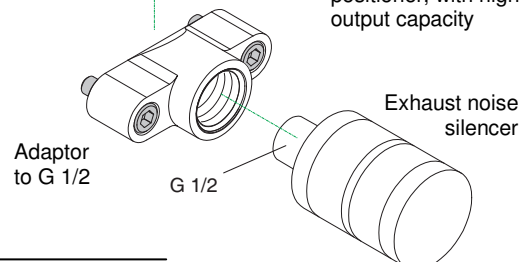

\* Unused threads for pressure are closed by means of lock screw Part No. 425 024 013.

## 4 MOUNTING TO LINEAR ACTUATORS

### 4.1 NAMUR Mounting - left hand -

Applicable to actuators with cast yoke or pillar yoke acc. to NAMUR (DIN IEC 534-6).

Mounting the positioner with pneumatic connections on the left side and electrical connections on the lower right side.

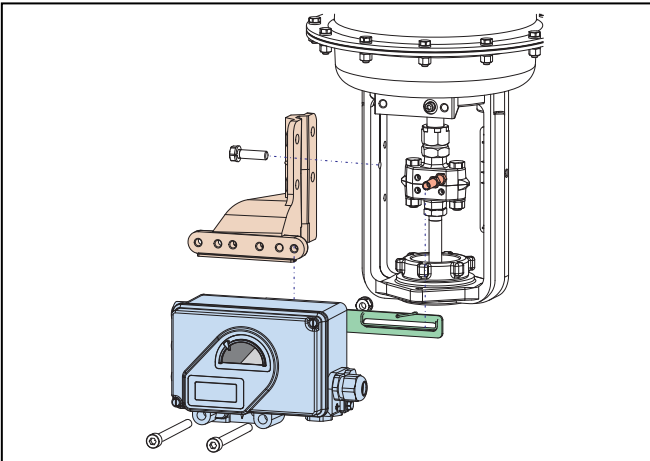

Attachment of the positioner to the actuator is made to the left using the mounting bracket and feedback lever for a NAMUR mount. Use:

Attachment kit EBZG -H for a cast yoke, or  
Attachment kit EBZG -K for a pillar yoke.

- The side outputs I (or I and II, see page 6) are used. The rear output I is closed by means of a lock screw 522 588 013.

Pneumatic connections: Do not use Teflon tape for sealant. The fine fibers could disturb the function of the SRI990. Use only Loctite® #243 for sealant <sup>1)</sup>.

Screw-type glands for electrical connections are positioned on the lower or right side. Any unused threaded holes are closed by plugs.

If housing cover has an air vent, this air vent must face-down when mounted.

#### 4.1.1 Preparation of the positioner

Rotate the shaft stub of shaft **9** so that the flat on the shaft stub is perpendicular to the arrow **26** on the housing (detail see page 13), at mid travel range. Fasten the feedback lever **A** to the shaft by means of spring washer and nut M8.

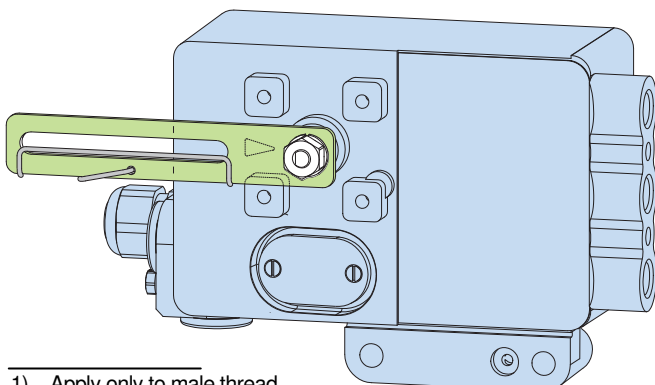

1) Apply only to male thread

#### 4.1.2 Preparation of the actuator

Screw the carrier bolt to the stem connector (see next page) and lock it by means of a counter nut.

A carrier bolt with an adjustable length is used to be able to screw on various coupling pieces.

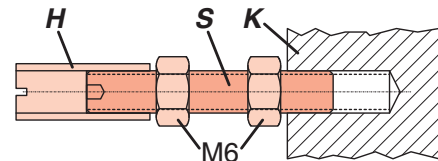

It consists of a stud **S**, which is screwed into the coupling piece **K** (with 3 mm Allen key) and locked with a lock nut M6. The threaded sleeve **H** is screwed onto it and locked with a lock nut M6. Make sure that the bolt is adjusted to the right length!

Fasten the mounting bracket to the left side of the yoke. For a cast yoke use a screw M8 x 30, for a pillar yoke use two U-bolts and four nuts.

#### 4.1.3 Mounting of the positioner

Fasten the positioner to the mounting bracket using two spring washers and two screws M8 x 80.

Note, the carrier bolt **B** is in the slot of the feedback lever **A** and the compensating spring **F** touches the carrier bolt.

Fig.: Feedback lever

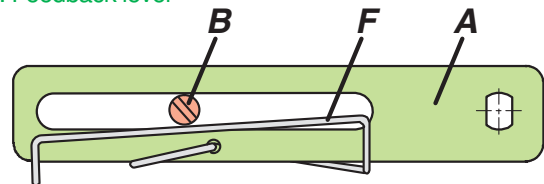

For optimum utilization of the positioner operating range, it is recommended that the arrangement is adjusted according to the following procedure before fixing. At an actuator position in the middle of travel range, the feedback lever position should be perpendicular to the actuator stem. The angle range should be between  $-10^\circ$  to  $+10^\circ$  and  $-45^\circ$  to  $+45^\circ$ .

Fasten the positioner to the mounting bracket so that a suitable angle range is selected.

It is recommended that the pneumatic and electrical connections are made after adjusting the position



4.1.4 NAMUR Mounting Dimensions – left hand –

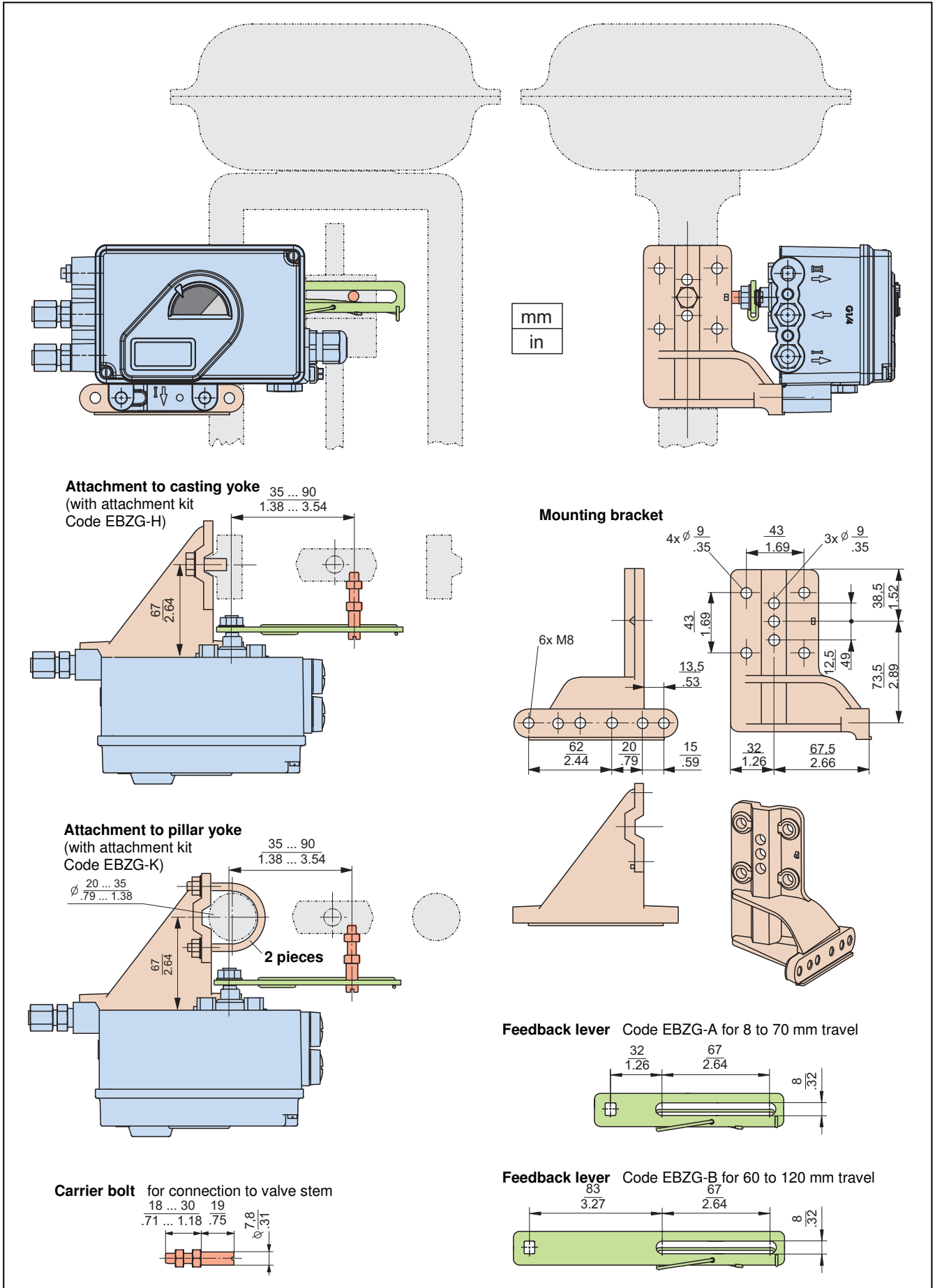

## 4.2 NAMUR Mounting - right hand -

Right-hand mounting is done if for instance left-hand mounting is not possible for structural reasons. Applicable to actuators with cast yoke or pillar yoke acc. to NAMUR (DIN IEC 534-6).

Mounting the positioner with pneumatic connections on the right side and electrical connections on the left side.

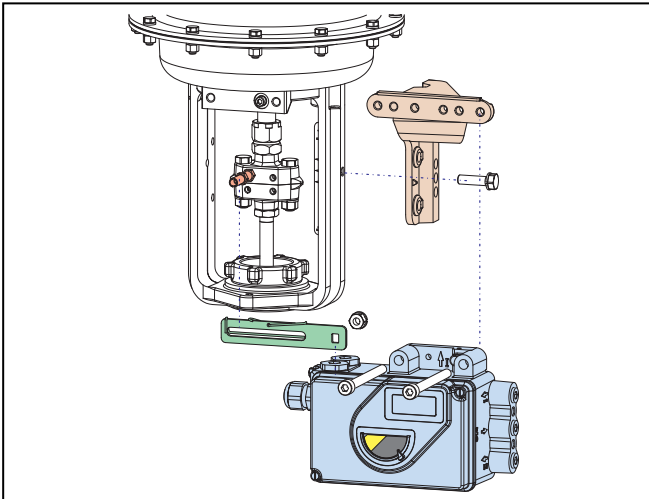

Attachment of the positioner to the actuator is made to the right using the mounting bracket and feedback lever for a NAMUR mount. Use:

attachment kit EBZG -H for a cast yoke, or  
attachment kit EBZG -K for a pillar yoke.

- The side outputs I (or I and II, see page 6) are used. The rear output I is closed by means of a lock screw 522 588 013.

Pneumatic connections: Do not use Teflon tape for sealant. The fine fibers could disturb the function of the SRI990. Use only Loctite® #243 for sealant <sup>1)</sup>.

Screw-type glands for electrical connections are positioned on the left side. Any unused threaded holes are closed by plugs.

If housing cover has an air vent, this air vent must face-down when mounted.

### 4.2.1 Preparation of the positioner

Rotate the shaft stub of shaft **9** so that the flat on the shaft stub is perpendicular to the arrow **26** on the housing (detail see page 13), at mid travel range. Fasten the feedback lever **A** to the shaft by means of spring washer and nut M8.

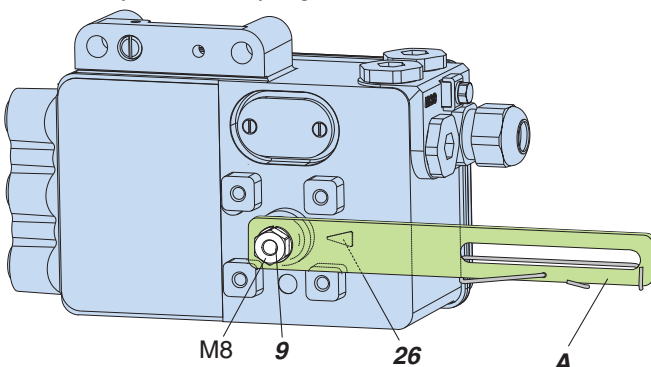

1) Apply only to male thread

### 4.2.2 Preparation of the actuator

Screw the carrier bolt to the stem connector (see page 9) and lock it by means of a counter nut. A carrier bolt with an adjustable length is used to be able to screw on various coupling pieces.

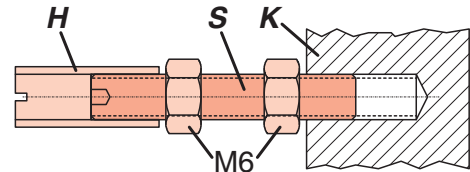

It consists of a stud **S**, which is screwed into the coupling piece **K** (with 3 mm Allen key) and locked with a lock nut M6. The threaded sleeve **H** is screwed onto it and locked with a lock nut M6. Make sure that the bolt is adjusted to the right length! Fasten the mounting bracket to the left side of the yoke. For a cast yoke use a screw M8 x 30, for a pillar yoke use two U-bolts and four nuts.

### 4.2.3 Mounting of the positioner

Fasten the positioner to the mounting bracket using two spring washers and two screws M8 x 80.

Note, the carrier bolt **B** is in the slot of the feedback lever **A** and the compensating spring **F** touches the carrier bolt.

Fig.: Feedback lever

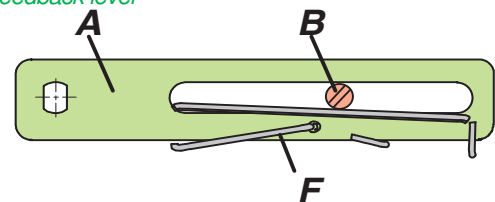

For optimum utilization of the positioner operating range, it is recommended that the arrangement is adjusted according to the following procedure before fixing. At an actuator position in the middle of travel range, the feedback lever position should be perpendicular to the actuator stem. The angle range should be between  $-10^\circ$  to  $+10^\circ$  and  $-45^\circ$  to  $+45^\circ$ .

Fasten the positioner to the mounting bracket so that a suitable angle range is selected.

It is recommended that the pneumatic and electrical connections are made after adjusting the position

4.2.4 NAMUR Mounting Dimensions – right hand

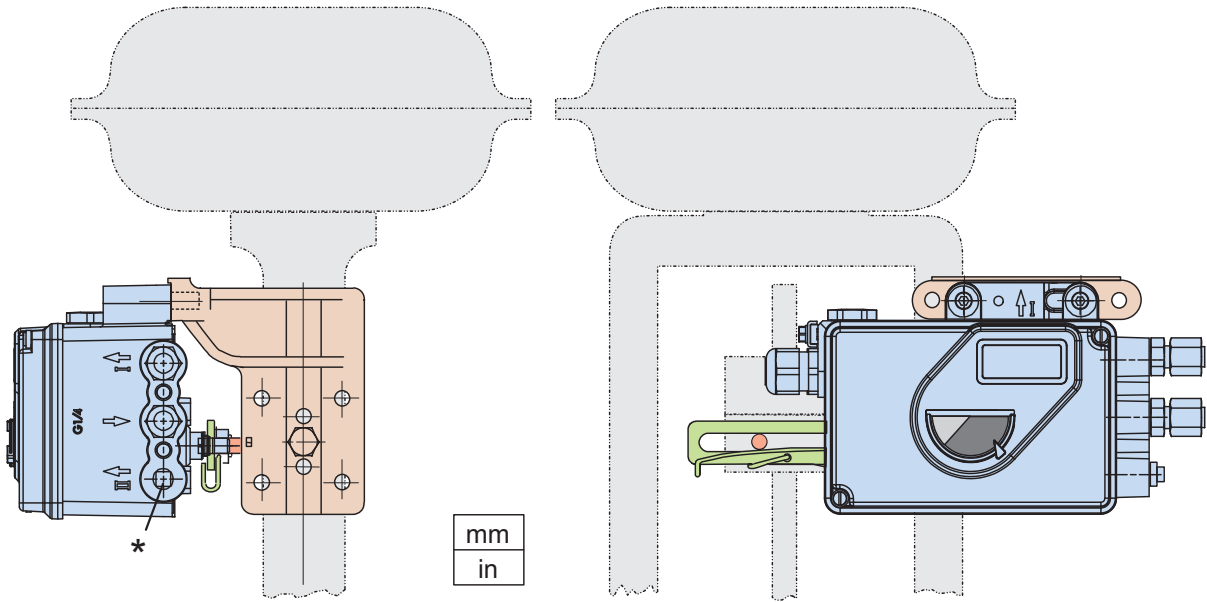

**Attachment to casting joke**  
(with attachment kit EBZG-H)

Mounting bracket, feedback lever and carrier bolt see page 9

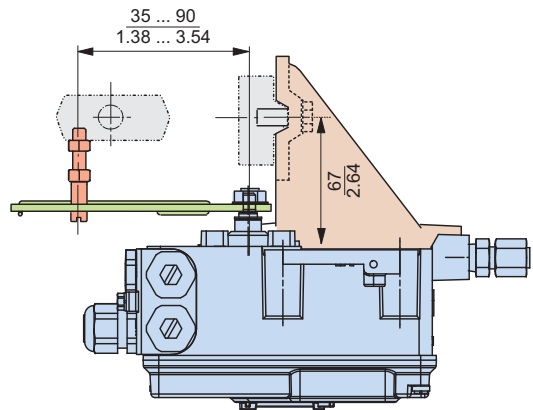

**Attachment to pillar joke**  
(with attachment kit EBZG-K)

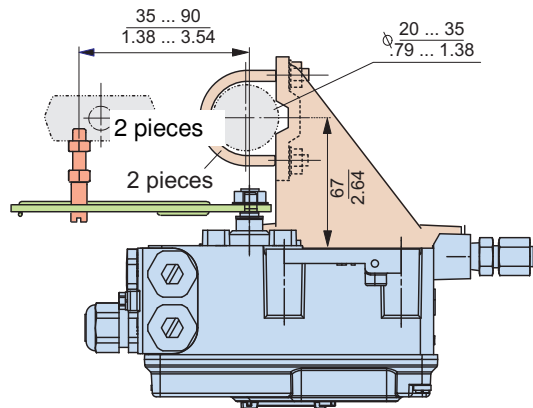

### 4.3 Linear actuator, direct mounting

Actuators with appropriately prepared yoke enable mounting of the SRI990 directly to the actuator yoke.

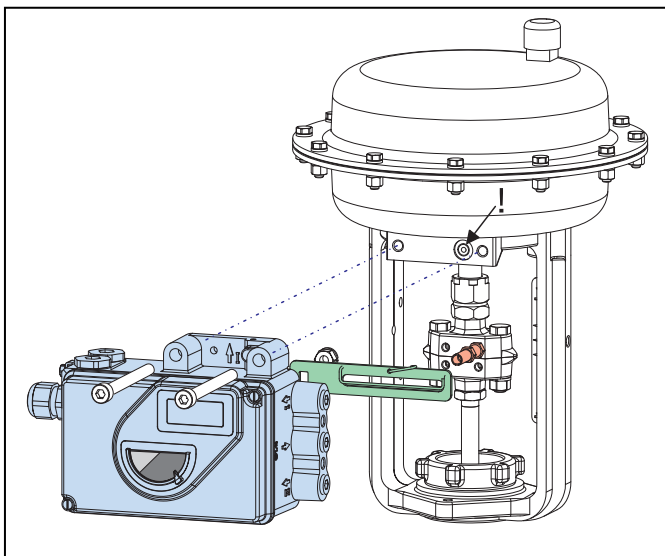

The attachment of the positioner is accomplished by bolting it directly to the actuator yoke using the feedback lever for a direct mount (with attachment kit EBZG -D).

The rear output I and the side outputs I and II are used as follows (see page 6) :

- Actuator single acting, spring force closes:  
The rear output I is used (remove lock screw in hole **D**).  
The side output I is closed by means of a lock screw 522 588 013.
- Actuator single acting, spring force opens:  
The side output I is used.  
The rear output I is closed by means of a lock screw.
- Actuator double acting:  
The rear output I and the side output II is used.  
The side output I is closed by means of a lock screw

Pneumatic connections: Do not use Teflon tape for sealant. The fine fibers could disturb the function of the SRI990. Use only Loctite® #243 for sealant <sup>1)</sup>.

Screw-type glands for electrical connections are positioned on the side. Any idle female threads are closed by means of plugs.

If housing cover has an air vent, this air vent must face down when mounted.

#### 4.3.1 Preparation of the positioner

Rotate the shaft stub of shaft **9** so that the flat on the shaft stub is perpendicular to the arrow **26** on the housing at mid travel range (detail see page 13). Fasten the feedback lever **A** to the shaft by means of spring washer and nut M8.

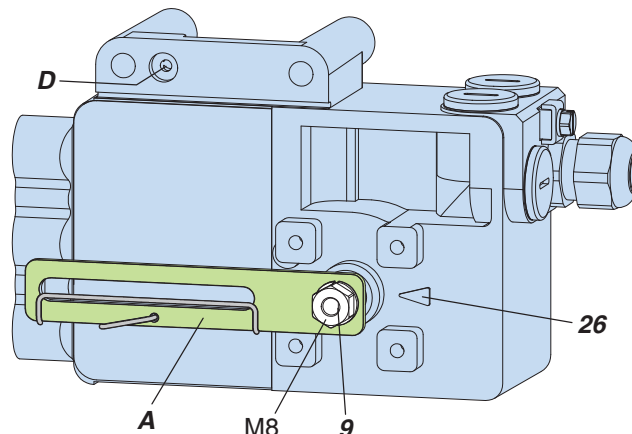

#### 4.3.2 Preparation of the actuator

Screw in the carrier bolt **B** on the coupling piece **K** on the drive spindle **S** at the lower left and lock it by means of a nut M6.

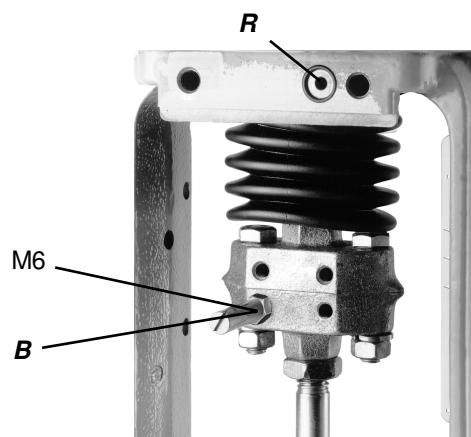

#### 4.3.3 Mounting of the positioner

Fasten the positioner to the upper part of the yoke using 2 spring washers and 2 screws M8 x 80, as shown above. The rear output I of positioner has contact to the air duct **R** in the yoke.

**Attention:** Note the correct position of the O-ring on the yoke for the rear connection 'I' !

Note, the carrier bolt **B** is in the slot of the feedback lever **A** and the compensating spring **F** touches the carrier bolt.

Fig.: Feedback lever

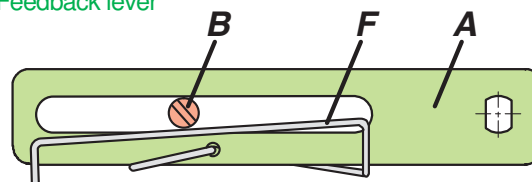

1) Apply only to male thread

4.3.4 Mounting dimensions – direct mounting –

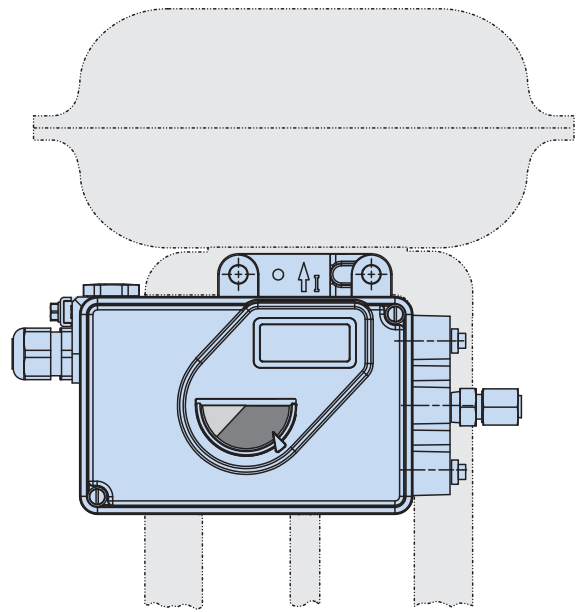
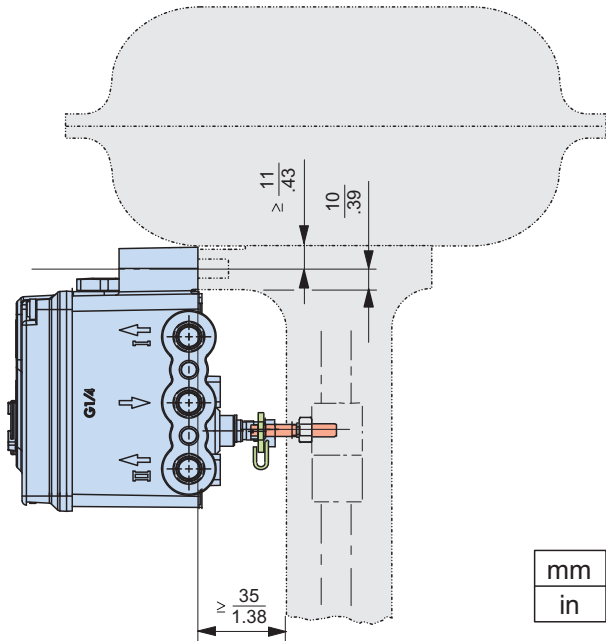

**Feedback lever** Code EBZG-A for 8..70 mm travel

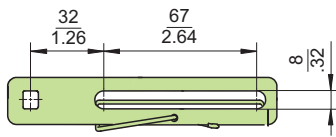

**Feedback lever** FoxPak/FoxTop in Code EBZG-E

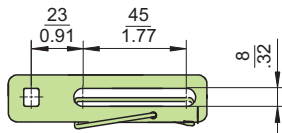

**Carrier bolt** for connection to valve stem

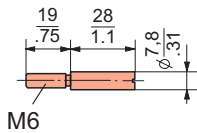

**Detail:** shaft stub 9 is perpendicular to the arrow 26 on the housing (at mid travel range)

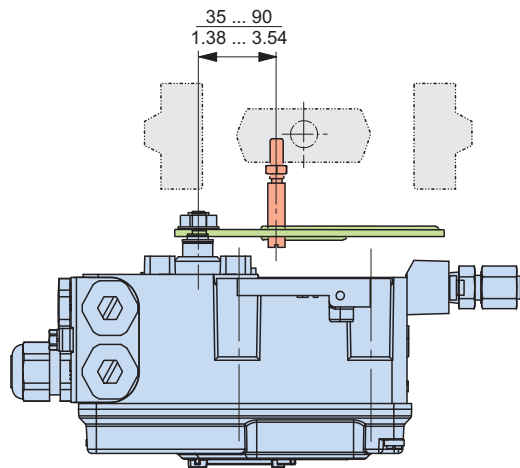
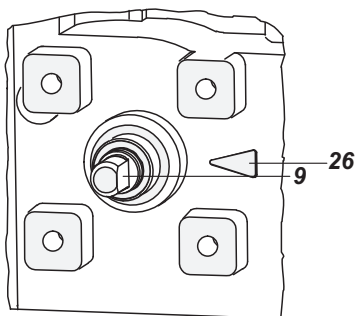

Connection to yoke using the direct connection hole for rear output I (y/y1)

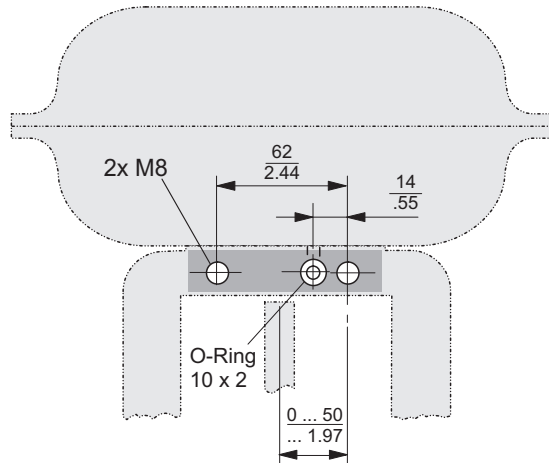





### 5.1.2 Preparation of the actuator

First the rotary adaptor is being prepared:

For attachment to a counter-clockwise or left turning actuator secure the stud screw **4** in the threaded hole “**L**” of the rotary adaptor; hole “**R**” remains open. See Fig. 27.

For attachment to a clockwise or right turning actuator secure the stud screw **4** in the threaded hole “**R**” of the rotary adaptor; hole “**L**” remains open. See Fig. 28.

Now place the rotary adaptor **3** with two washers **5** on the feedback shaft **9** of the positioner against the stop.

Note: Stud screw should always be tightened into flat on feedback shaft **9**.

When the product temperature rises, the drive shaft **1** becomes longer. Therefore, the rotary adaptor **3** must be mounted so that approx. 1 mm (0.04 in.) of clearance results between the drive shaft **1** and the rotary adaptor **3**. This is achieved by placing an appropriate number of washers **5** on the feedback shaft stub **9** before attaching the rotary adaptor. Two washers should result in a clearance of 1 mm.

Now screw and tighten the bolt in the coupling against the flat part of the feedback shaft (do not screw against thread!).

Finally turn the feedback shaft in such a way that the arrow of the coupling points to the arrow of the SRD housing. Beginning and end positions of the actuator drive shaft **1** and feedback shaft **9** are marked in figure 27 (left-rotating actuator) and in figure 28 (right-rotating actuator) by arrows for the respective direction of rotation.

The feedback shaft is now in the normal position corresponding to the failsafe position of the actuator.

### 5.1.3 Mounting of positioner

SRI990 and actuator are in failsafe position.

Attach the SRI on the console in such way that the catch of coupling **3** is guided into the groove of shaft **1**. Use bolt **2** to center and align the positioner to the actuator. Be careful not to shift shafts **1** and **9** and that both shafts are exactly flush.

Fasten the positioner to the bracket by means of 4 lock washers and 4 screws M6 x 12.

Figure 27: Mounting if actuator is left-rotating

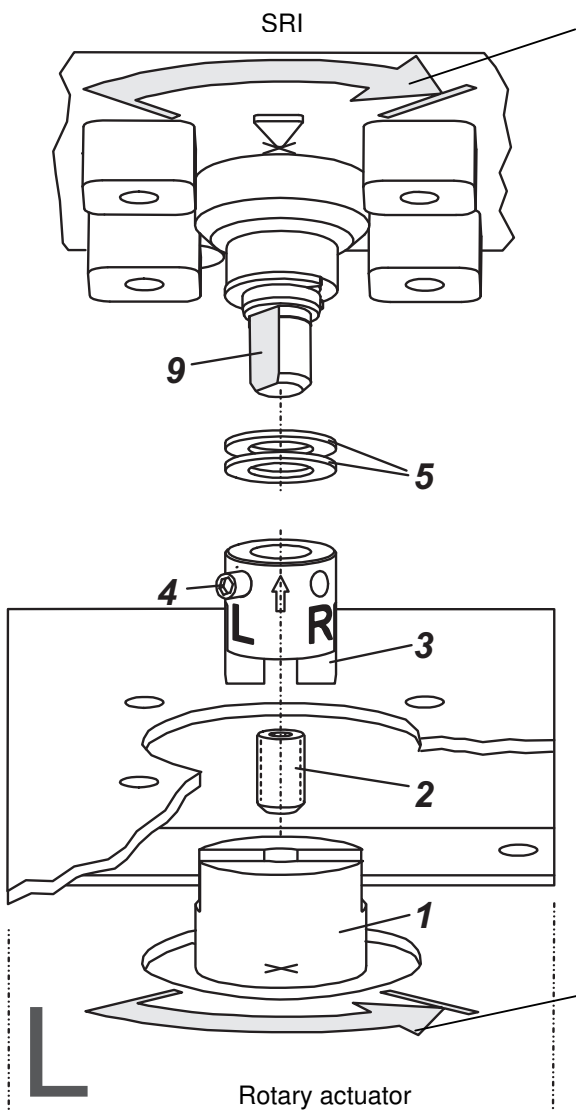
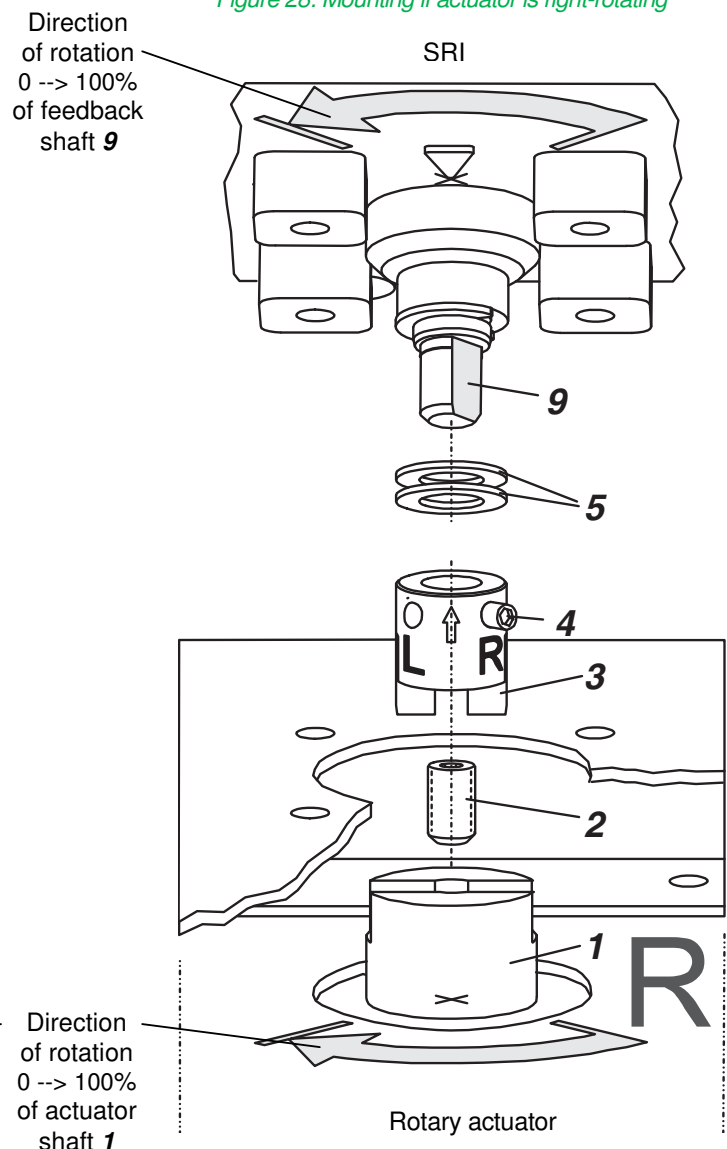
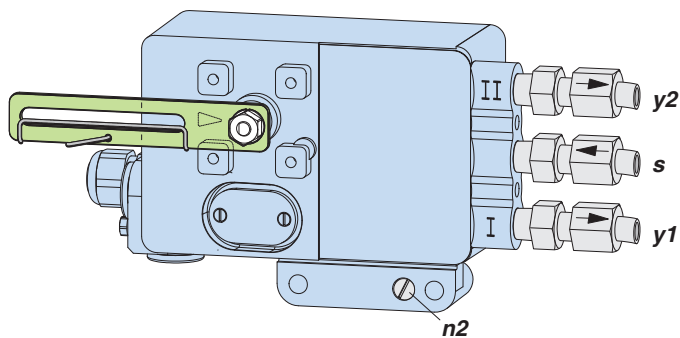
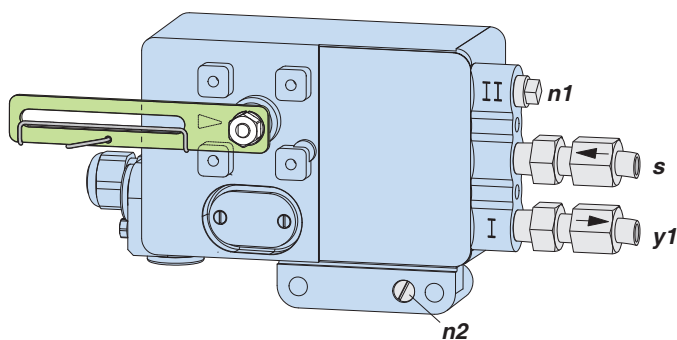
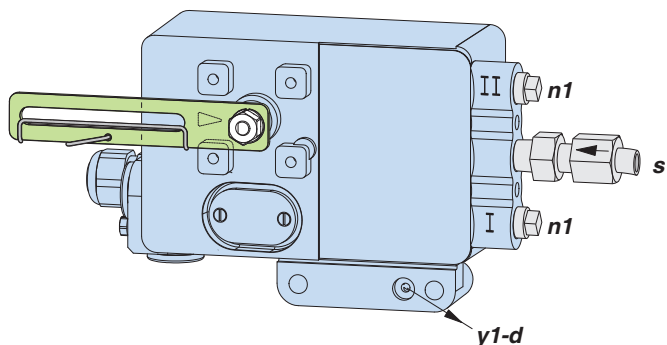

Figure 28: Mounting if actuator is right-rotating



## 6 PNEUMATIC CONNECTIONS



Following alignment and mounting of the positioner to the valve, pneumatic tubing has to be provided.

The connection illustrations depend on the respective version.

Explanation of abbreviations:

S Supply air

y1-d Output 1 for direct mounting, depressurized at currentless electronics. When using this output y1 has to be closed by means of hex. screw.

y1 Output 1, depressurized at currentless electronics. When using this output, y1-d has to be closed by means of sealing screw and O-ring.

y2 Output 2 for double-acting actuator. Full pressure at currentless electronics. Closed at single-acting actuator.

n1 Hex. screw with NPT thread

n2 Sealing screw with O-ring

Air supply. . . . . according to ISO 8573-1

Solid particle size and density . class 2

Oil rate . . . . . class 3

Pressure dew point 10 K under ambient temperature

### 7 ELECTRICAL CONNECTION

The safety requirements on page 4 must be observed!

Unused cable glands should be closed off.

Guide cable through gland **1**. The gland is suitable for cable diameters of 6 to 12 mm (0.24 to 0.47 in). Observe the tightness of the cable entry.

Provide electrical connection of input line at screw terminals marked 11+ and 12-. The terminals are suitable for wire cross-sections of 0.3 to 2.5 mm<sup>2</sup> (22 -14 AWG).

Note: When connecting shielded cable connect the cable shield only to the system! Do not connect the cable shield to the SRI !

Connection to terminals (pos. **3+**, **3-**):

11+ Input w+

12- Input w-

(Options see table below)

The input current can be measured at tip jacks 23+ and 23- (integrated in terminals, underneath the screws). The tip jacks fit plugs with a diameter of 2 mm (0.08 in).

In order to improve EMV protection by integration into local grounding the internal and external grounding conduct connection **4** is available.

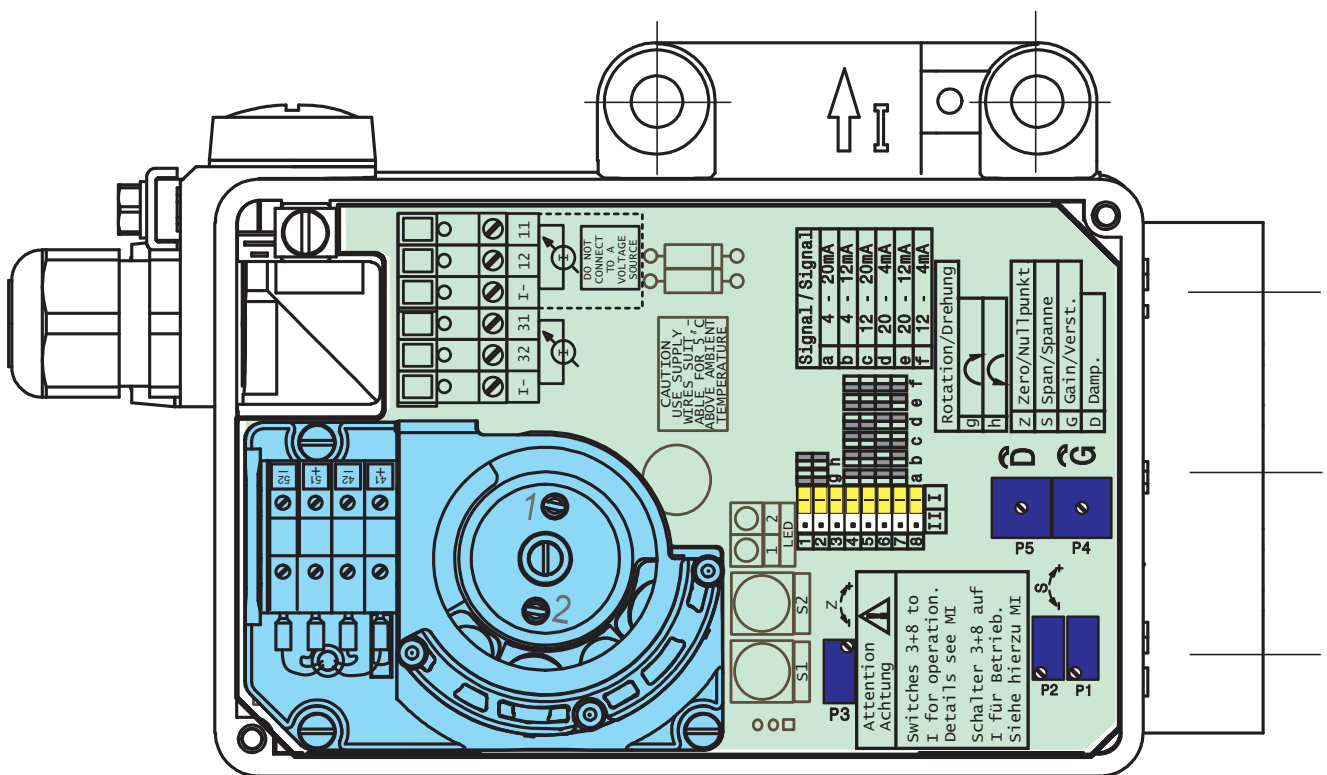

Mark	Signal
11 +	Input W +
12 -	Input W -
<b>Option Position Feedback + Alarm</b>	
31 +	Position Feedback 4 to 20 mA (+)
32 -	Position Feedback 4 to 20 mA (-)

SRI990-xxxT, U, via inductive sensors	
Mark	Signal
41 +	GW1
42 -	GW1
51 +	GW2
52 -	GW2

GW: Binary output, ext. supplied

## 8 START-UP

### 8.1 General

First of all, the nameplate should be checked, especially with respect to references to Ex / non- Ex, input signal, single / double acting.

Before starting the positioner the SRI must be mounted to the actuator; and an input signal 4 to 20 mA or split range must be available. The supply air connection must have sufficient capacity and pressure of 1.4 to 6 bar (20 to 90 psig) and should not exceed the maximum operating pressure of the actuator.

The SRI990 can be adjusted by means of switches and potentiometers when the housing cover is opened.

Attention: Configuration using switches and potentiometers may interfere with operation of the actual process! During configuration, it is recommended that there is no flow through the valve.

At initial start-up various adjustments have to be set. The following procedure is recommended:

- Setting of direction of rotation of feedback lever (chapter 8.2)
- Setting of input signal range e.g. 4 to 20 mA or split range (chapter 8.3)
- Setting of gain (chapter 8.4)
- Setting of zero and span (chapter 8.5)
- Setting of damping (time constant, chapter 8.6)
- The position indicator **12** is attached to the desired position after selection of the transmission at indicator shaft (chapter 8.7)
- If housing cover has an air vent, this air vent must face-down when mounted. When attaching the housing cover make sure that the vent drain points toward the bottom.

#### Settings via switches and potentiometers

For the setting of the SRI990 and the adjustment of various parameters 8 dip switches and 5 potentiometers are available. See electronics imprint as follows:

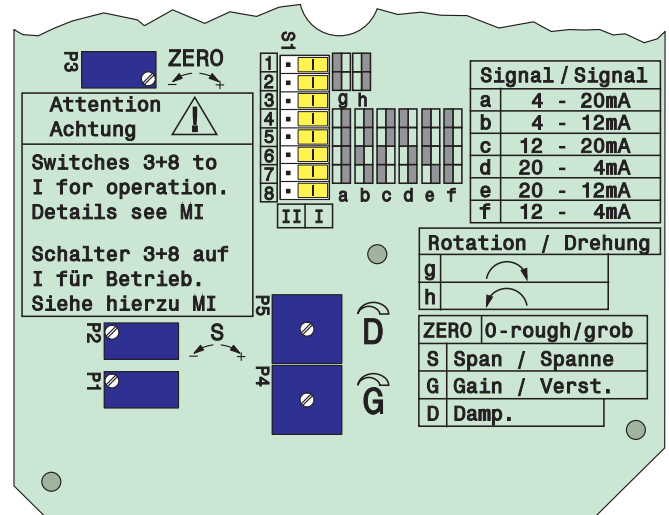

The potentiometers are for the setting of:

- Zero point (ZERO): P3
- Span (S): P2
- Gain (G): P4
- Damping (D): P5
- Electronics alignment: P1<sup>1)</sup>

Single-threaded potentiometers with limited rotation angle to set gain (G) and damping (D) are available, where the actual position is indicated by an arrow. To set zero point (ZERO), span (S) and the electronics alignment<sup>1)</sup> multiple-threaded potentiometers (approx. 30 rotations) without rotation limitation are used.

The switches are for the setting of:

- Direction of rotation of feedback lever (switches 1, 2)
- Electronics adjustment (switch 3)<sup>1)</sup>
- Signal range (switches 4, 5, 6 and 7)
- Pneumatic test (switch 8)

The switch numbers (1 through 8) are imprinted on the electronics. The possible switch position ("I" and "II") are imprinted below switch 8. The switch positions are defined as follows:

Switch Position "I":



Switch Position "II":

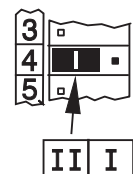

#### Caution!

Switches 3 and 8 must be in position "I" during operation. Prior to resetting switches 1 to 8 it is recommended to shut-off the respective part of the installation since processes are activated influencing and disturbing the current process. Therefore, it is recommended that no medium flows through the valve during configuration.

<sup>1)</sup> Adjustment of electronic board (in workshop), see page 22

## 8.2 Setting of direction of rotation of feedback shaft

If the actuator moves from starting to end position, the direction of rotation of the feedback shaft is to the right or left hand, depending on the mounting method of the positioner selected and on the configuration of the actuator (spring closes/ opens/ double-acting).

For proper functioning this direction of rotation must be set at positioner (via switches 1+2).

The direction of rotation is defined as direction of rotation of the feedback shaft from the starting to the end position looking at the positioner from the front. See following illustration (shown is: left hand mounting, spring closes, direction of rotation L).

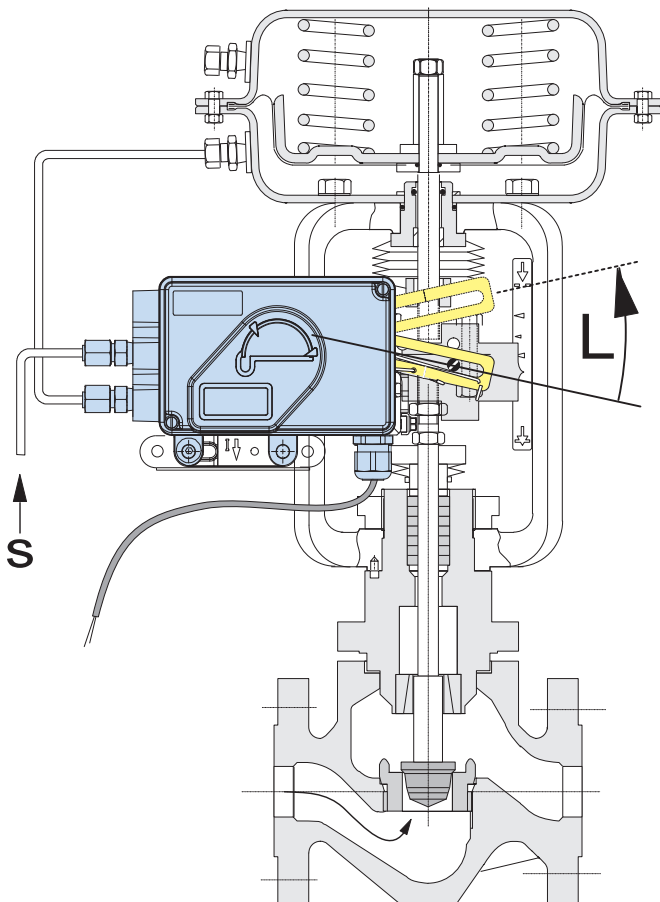

Direction of rotation of feedback shaft of a single-acting **stroke actuator** with spring:

Left hand mounting, direct mounting	Spring in actuator	Right hand mounting
<b>L</b>	Spring closes	<b>R</b>
<b>R</b>	Spring opens	<b>L</b>

Direction of rotation of feedback shaft for a **rotary actuator**

Actuator opens rotating to the left	Actuator opens rotating to the right
<b>L</b>	<b>R</b>

Direction of rotation of feedback shaft of the double-acting actuator is a. o. determined by the mounting side and the tubing of the pneumatic outputs to the actuator. It has to be considered that in a powerless SRI990 the output y1 will become pressureless, and y2 has air supply pressure.

The direction of rotation of the feedback shaft is set via switches 1+2; see the following illustration.

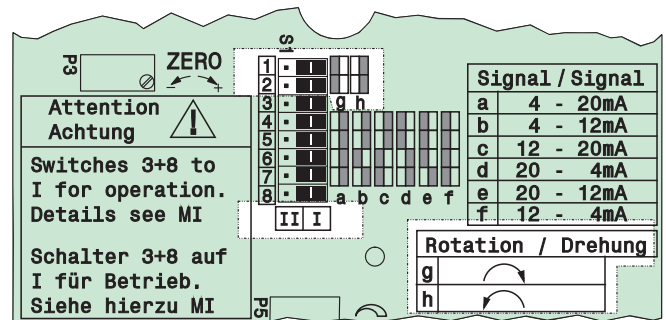

L: left-hand rotating feedback shaft: switch 1+2 on "I"  
 R: right-hand rotating feedback shaft: switch 1+2 on "II"

Remarks: If the direction of rotation is not in the right manner, the actuator moves to the end position with full force, and the positioner cannot control.

### Definitions

**Stroke, stroke range** of the membrane actuator is defined for rotary actuator as **angle, angle range, ...**

**0 % position** is the mechanical impact at actually closed valve (caution if using hand wheel and mechanically adjustable stroke limitation!)

**100 % position** is the mechanical impact at actually open valve

### 8.3 Setting of Input Signal Range

The following input signal ranges can be set via switches 4 to 7:

0 %	100 %	item	S4	S5	S6	S7
4 mA	20 mA	a	I	I	I	I
4 mA	12 mA	b	I	I	II	I
12 mA	20 mA	c	I	I	II	II
20 mA	4 mA	d	II	II	I	I
20 mA	12 mA	e	II	II	II	I
12 mA	4 mA	f	II	II	II	II

The switch positions for the setting of various signal ranges are imprinted on the electronics. See illustration.

For 4 to 20mA the switches 4 to 7 are set to position "I" (as shown). This concludes the setting of the input signal range!

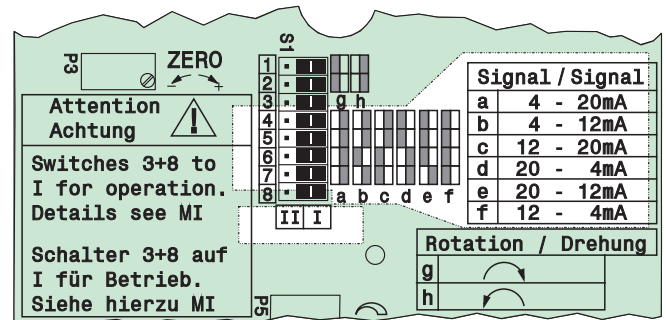

### Split Range

If several positioners are operated at one current loop in sequence with the standard signal 4 to 20 mA, individual valve positions may be allocated to each device, which also may overlap if necessary.

This function is useful if an additional control range is demanded which cannot be covered by one valve only. A valve of smaller nominal size can be applied to the smallest quantities; a parallel mounted valve of bigger nominal size takes on the larger quantities.

Example: Setting the signal range to 12 to 20 mA

It is recommended to shut off current of the positioner prior to resetting of the input signal range (turn-off input signal). The switches 4 and 5 are set to position "I" and switches 6 and 7 to position "II".

The individual switch positions are shown in the following illustration.

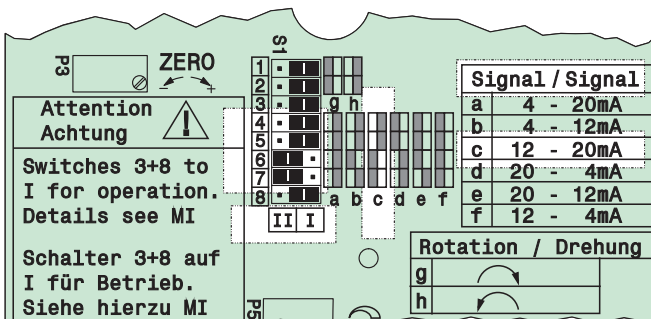

Split range, subdivision of input signal range

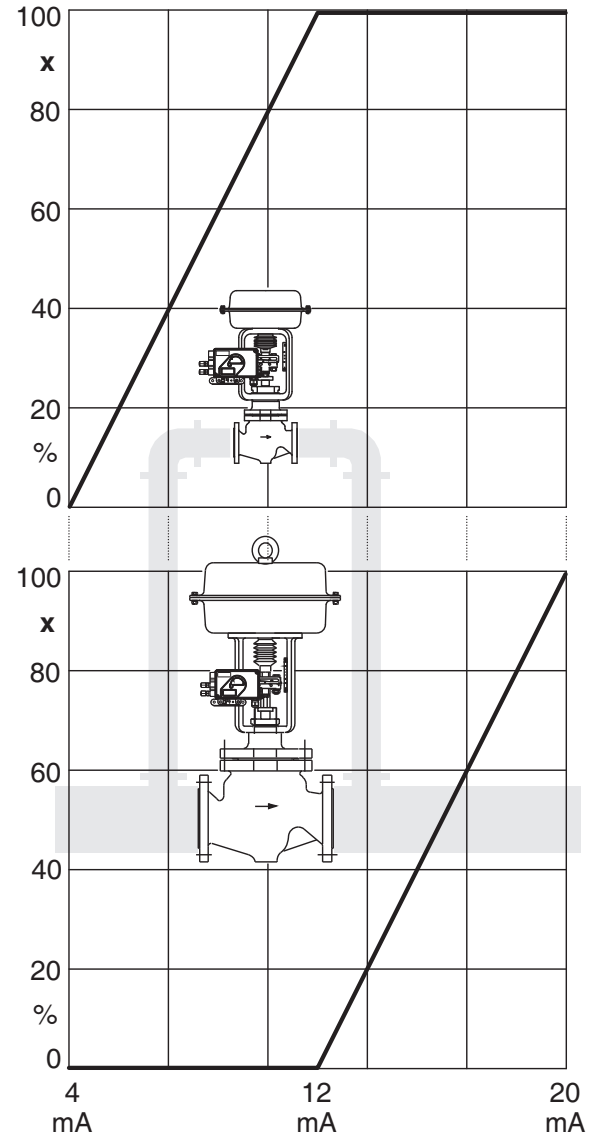

Example: At low current, only the smaller valve positions.  
From approx. 50 %, the large valve is added.



## 8.4 Setting of gain (G)

The loop amplification of the positioner is set via potentiometer P4 for gain (G). The maximum possible gain is thereby determined by the stability behavior of the control loop. It is selected in such a way that the actuator no longer oscillates at constant given input value.

Rotation to the right P4: amplification is increased  
Rotation to the left P4: amplification is reduced

If the positioner control loop oscillates, gain (G) must be reduced. It has to be considered that a change of gain changes the control deviation; therefore, requiring setting of the potentiometer for the position range (zero and span).

## 8.5 Setting of zero (ZERO) and span (S)

Following settings in chapters 8.2 through 8.4 at initial start-up setting of zero point (ZERO) and span (S) are performed as follows:

- Enter starting value of command variable (beginning of stroke).
- Turn potentiometer P3 for zero point (ZERO) until actuator just begins to move from its end position.

Rotation to the right P3: zero point is increased  
Rotation to the left P3: zero point is reduced

- Enter final value of variable (end of stroke)
- Turn potentiometer P2 for span (S) until actuator exactly reaches its end position.

Rotation to the right P2: span is increased  
Rotation to the left P2: span is reduced

These settings influence amplification, therefore adjusting in chapter 8.4 may become necessary.

## 8.6 Setting of damping (D)

Potentiometer P5 for damping (D) influences the dynamic behavior of the actuator at a discontinuous change of the input signal. The input signal is provided with an additional time constant for this purpose. The time constant is only noticeable in the position control loop if the time constant set via potentiometer is larger than the position time of the actuator.

Rotation to the right P5: damping is increased  
Rotation to the left P5: damping is reduced

The effect of the positioning time may be checked by entering input signal jumps. The range limits and the gain are not influenced by a change.

## 8.7 Setting of the travel indicator

The mechanical travel indicator is coupled to the feedback shaft of the positioner by a gear. The gear has two selectable ratios 1 : 2 and 1 : 6.<sup>1)</sup>

### Selection of gear ratio:

For rotation angles of the feedback shaft less than 30° select a ratio 1 : 6. This gear selection amplifies the feedback shaft rotation angle six times and for example, a 20° angle is shown as 120°.

For rotation angles greater than 30° select a ratio of 1 : 2. This gear selection amplifies the shaft rotation angle by a factor of two and for example, a 45° angle is shown as 90°.

For rotary actuators the rotation angle is equal to the rotation angle of the actuator. Consequently, a 90° rotation angle will result in a 180° display angle for the 1 : 2 gear ratio.

For linear actuators the rotation angle is determined by travel span and feedback lever length. In this case, an exact 180° display angle can only be achieved for a 30° rotation angle using a 1 : 6 gear ratio. If any other rotation angle results, either the closed or full open position can be set to be indicated at, for example, 0° or 180°. However, if the closed position is chosen for display, then the full open display position angle is dependent on travel span, feedback lever length and gear ratio. If the full open position is chosen for display, then the closed position angle becomes dependent.

### Setting gear ratio:

Remove travel indicator **12**. Pull out pin **12b** for a ratio 1 : 2 or push in the pin for a ratio 1 : 6. Use a smooth turning operation to free the gears and to set pin **12b** against the stop. See illustration.

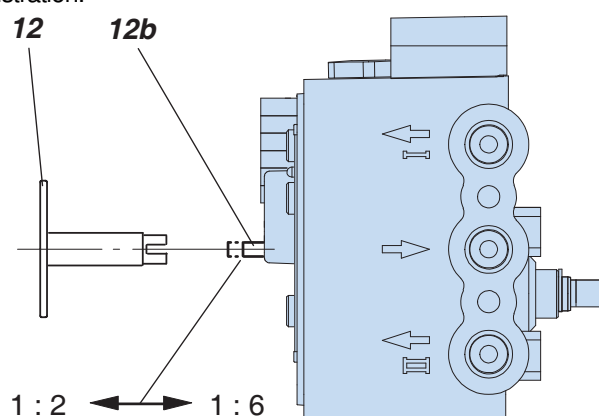

Turn the travel indicator **12** to the desired position, put it on the gear shaft against the stop and pinch the wire ring for secure coupling.

1) The values are rounded for making easier calculations. The exact ratios are 1 : 1.83 and 1 : 6.28 .

## 8.8 Start-Up of Position Transmitter (4-20 mA) for SRI990-xIQxxx

### General

The electrical position transmitter is an accessory installed in the factory. It converts the stroke or rotary movement of an actuator into an electrical standard signal 4 to 20 mA. Attachment and start-up of the unit to the actuator must be performed according QG EVE0107 A. At 50 % stroke, the control lever must be horizontal. The electronic connection of the position transmitter must be assured. Both LEDs then light up.

### Adjusting the start of the measuring range (4 mA)

- Move the actuator to the starting position.
- Press push button S1 "Config output 4 mA" longer than 2 s. During this time LED 1 lights up. After 2 s both LEDs are light up again, the value for 4 mA is stored.

### Adjusting the end of the measuring range (20 mA)

- Move the actuator to the end position.
- Press push button S2 "Config output 20 mA" longer than 2 s. During this time LED 2 lights up. After 2 s both LEDs are light up again, the value for 20 mA is stored.

### Random adjustment of the current values at the end points

- Move the actuator to the end position, where you want to adjust the current.
- Press both buttons simultaneously for about 2 s. Then both LED's are alternating flashing in a slow frequency.
- With push button S2 "Config Output 4 mA" the output current value can be increased. Pressing the buttons for a short moment results in a small change and pressing the button for a longer time results in a fast mode for a bigger change. The value of the current can be freely decreased between about 3.3 and increased up to 22.5 mA.
- Without any additional manipulations of the push button the new value is automatically saved. After a few seconds, the device returns into the normal operating mode, indicated by both LEDs that are then light up again.

### Trouble shooting of the position transmitter

The components of the position transmitter are under constant surveillance by the installed micro controller. Errors are detected and indicated when both LEDs are off or both LEDs are parallel flashing at a fast frequency. In the event of fatal error, e.g. potentiometer not connected, an output current of more than 24 mA will be shown in addition to the error indication given by the LEDs (fast flashing).

In this case check the following:

- If the potentiometer is correctly connected to the electronic board.
- If the potentiometer is within its working span.

When both LED's are off, the supply voltage should be checked (minimum tension, polarity).

## 8.9 Basic adjustment of electronics

**Attention:** Service only

The electronics unit has been sufficiently factory-adjusted; an adjustment at delivery is not required. The potentiometer is secured by means of lacquer against unintentional operation. In the event an adjustment of the electronics becomes necessary (e.g. following exchange of electronics), the procedure is as follows:

- Enter input current 4 mA.
- Switch S3 to "II": positioner control loop is opened.
- Turn potentiometer P1 until actuator just begins to move from its end position.
- Return S3 to "I".

## 8.10 Pneumatic test

**Attention:** Service only

To check the pneumatic parts of the positioner by directly applying current to the IP module (no control).

Procedure: Put switch 8 in position "II" (see illustration).

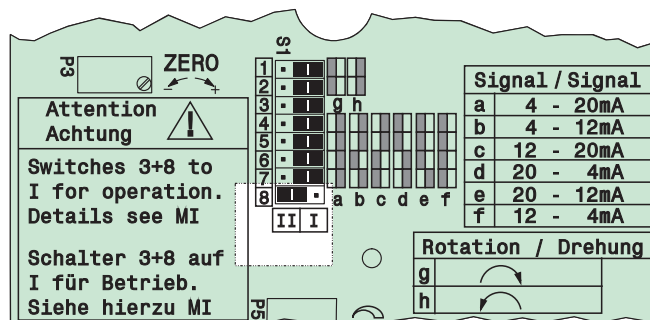

### Attention!

Resetting of switch 8 initiates actions influencing and possibly disturbing the current process! Therefore, no medium should flow through the valve during these settings.

Setting switch 8 to position "II" actuates a pneumatic test, checking the function of the positioner's pneumatic system, including its control. If switch 8 is set from position "I" (condition of operation) to position "II", the pressure in the actuator goes to nearly full air supply pressure. The actuator moves in the direction associated with maximum pressure.

If no reaction is shown, check:

- does air supply exist?
- is plug connected to IP module?

If these items are okay, possibly the electronics, or a pneumatic part, is defective. Exchange see page 24.

During operation, switch 8 must be in position "I" at all times!

## 9 DECOMMISSIONING

Before decommissioning the unit, disconnect supply air and the electrical input signal.

## 10 DIAGNOSTICS

Fault	Possible cause	Solution
Actuator does not react to existing input signal or to changes of input signal	Pneum. connections were interchanged	Check pneum. connections, see page 16
	Electric connections were interchanged	Check electric connections, see page 17
	Wrong setting of zero and span	Check, see page 21
	IP module or pneumatic part defective	Carry out Pneumatic Test, possibly change part, see page 25
Output pressure does not reach full capacity	Direction of rotation interchanged	Change direction of rotation
	Supply air capacity insufficient	Check air supply
	IP module defect	Carry out Pneumatic Test, possibly change module, see page 25
Actuator moves to end position	Filter in air supply connection plugged	Exchange filter, see page 24
	Positioner mounted on wrong side or switch1+2 set faulty (R/L)	Check mounting side as per table page 19
	Pneumatic test still active (switch 8 = "II")	Return switch 8 to "I", see page 22
Unstable behavior, position control circuit oscillates	Pneumatic connections were interchanged (double-acting version)	Check connections, see page 16
	Gain too high	Reduce gain, see page 21
	Friction on valve packing too great	Loosen packing gland slightly or replace
Stroke range cannot be set	Piston actuator: Friction at cylinder too great	Reduce gain, see page 21
	Positioner does not fully decompose pressure	Check air supply (max. 6 bar)
		Check gain, see page 21
Pneumatic test is without effect	Carry out pneumatic test (switch 8 = "II"), see page 22	
	No air supply	Connect air supply
	No input signal	Connect input signal
IP module is not connected, or IP module or a pneumatic part defective	IP module is not connected, or IP module or a pneumatic part defective	Connect IP module, or exchange part (workshop)

## 11 MAINTENANCE

### 11.1 General

The positioner SRI990 requires little maintenance. When replacing components during repair work, the safety requirements on page 4 must be observed!

### 11.2 Supply filter replacement

An obstructed supply filter can be replaced. Unscrew the air supply fitting, remove the filter and exchange the filter with a new one.

### 11.3 Removal of electronics unit

Pull off travel indicator **12**. To remove the electronics unit **40**, loosen the **7** screws at front, see illustration below.

Lift off electronics unit vertically to top. Disconnect plugs **41** and **42** (see page 25) from the board. Do not use tools to remove plugs because components could be damaged. Tight-fitting plugs can be easily removed by tilting them diagonally inward before pulling them off.

Connect plugs **41** and **42** to the new electronics unit **40** and attach the new unit by using the 7 screws at front (attention with the cables).

### 11.3.1 Conversion of positioner

Positioners of the POSYS series have identical mechanical and pneumatic components and accessories. A conversion to either a "digital" or "intelligent" positioner is possible by simply exchanging the electronics unit.

Please refer to TI EVE0102 U for an upgrade.

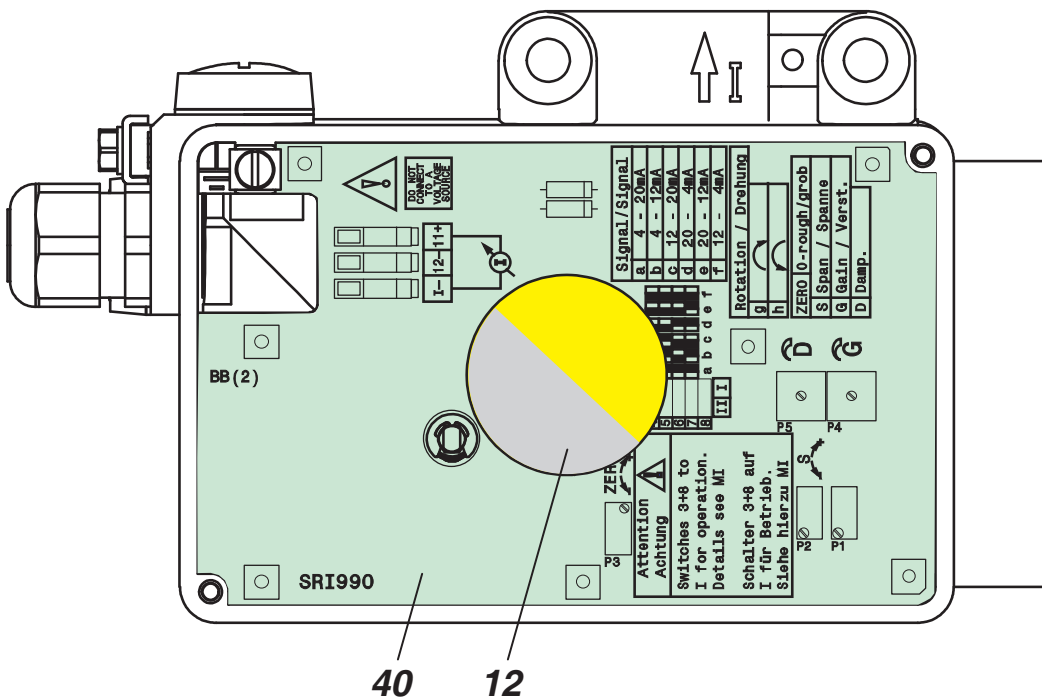

**11.4 Replacement of mechanical and pneumatic units**

First remove the electronics unit **40** (see previous page).

**11.4.1 Amplifier replacement**

Release the pneumatic amplifier **43** from the base plate and replace O-rings between the amplifier and base plate <sup>1)</sup>. Use 3 O-rings for a single-acting amplifier and 5 O-rings for a double-acting amplifier.

If replacing a single-acting amplifier with a double acting, remove sealing screw **44** before installation.

The air capacity throttle screws have to be released until the screw head is even with the amplifier surface ( = no throttling).

**11.4.2 Preampifier replacement**

Unscrew the preampifier **45** from the base plate by removing screws **46** and **47**.

Replace 4 O-rings between preampifier **45** and base plate <sup>1)</sup> and install new preampifier.

**11.4.3 Replacement of IP module**

Remove the IP module **48** from base plate and replace with new IP module. Replace the O-ring between IP module and base plate and install new IP module.

**11.4.4 Replacement of Feedback unit**

First remove feedback lever or rotary adapter from feedback shaft. Now remove retaining ring from feedback shaft **9** (see page 6). Remove screws and pull out complete unit **49** consisting of feedback shaft, gears and position sensor.

Insert new feedback unit **49** and secure with screws. Remember to replace the retaining ring at feedback shaft.

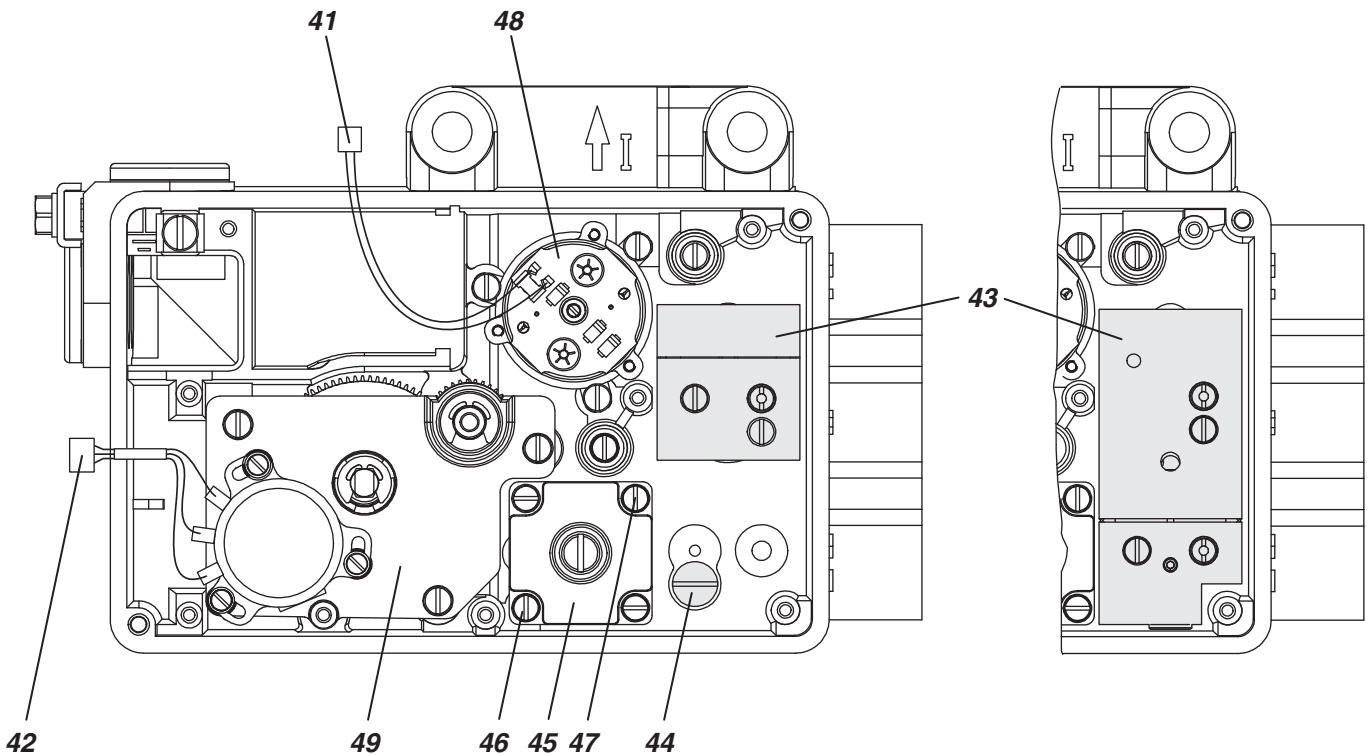

1) The base plate consists of a manifold and air ducts.  
O-rings are required to guarantee sealing of the mounted elements.

## 12 OPTION "Limit switch"

### Mounting

Remove three screws **A** including tooth lock washer from plastic cover.

Attach limit switch **B** so that the flattened shaft end **19** contacts the groove of the limit indicator shaft in the positioner.

Attach limit switch by means of three screws **C** and washers. The feedback shaft at back of positioner should easily be turnable, thereby also moving the vanes of the limit indicator. If this is not the case, loosen screws **3** and flush align the shafts of positioner and limit switch (turn coupling shaft several times). Replace short travel indicator **12** by long travel indicator. Screw high cover **28** (or standard cover with insert frame) on housing.

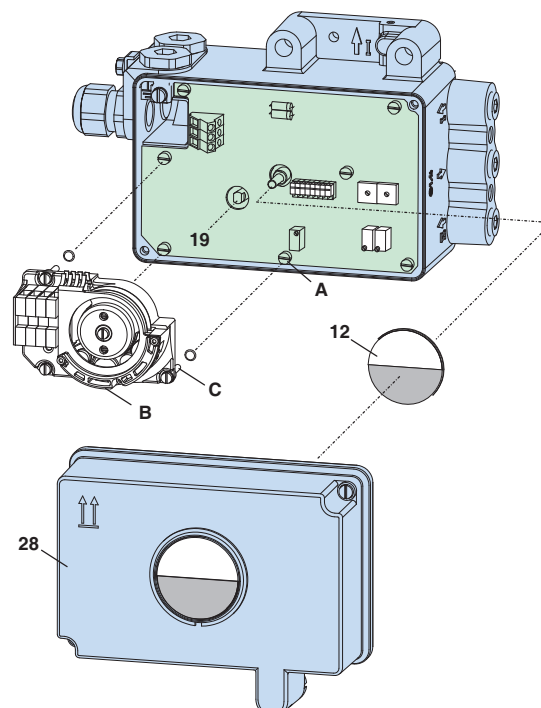

### Switch functions

Feedback lever, feedback shaft and the control vanes are all connected to each other, without an intermediate transmission. The control vanes are therefore moving simultaneously with the same angle rate as the feedback lever. The length of the control vane corresponds with the swing angle of 120°.

Both control vanes are located on different planes. Each control vane can be seen independently from the other, because each has its own sensor.

By adjusting the screws (after loosening the center screw **S**), the control vanes can be adjusted relative to the angle rate, so that e.g. one vane dives into and another dives out of the sensor (see illustration).

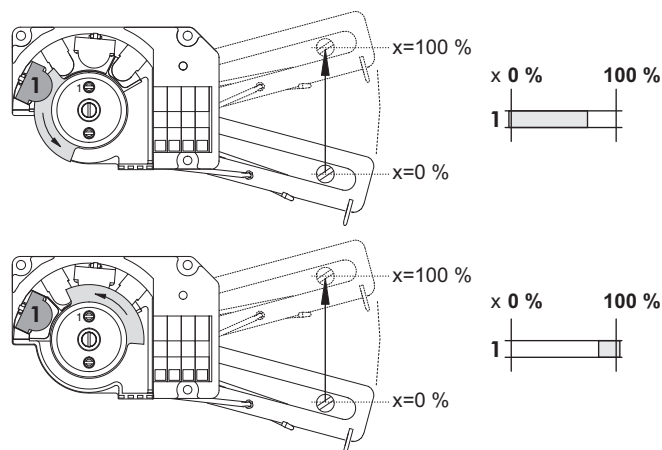

### Setting limit switch trigger points

Do not touch control vanes during operation  
Danger of injuries!

First loosen screw **S** until disc **D** is no longer blocked by bolt **B**. Then turn disc by 90°, until set screws 1 and 2 are accessible.

#### Set trigger point switch GW1:

Turn screw **1** at mark (•), until desired switch behavior is reached.

#### Set trigger point switch GW2:

Turn screw **2** at mark (••), until desired switch behavior is reached.

To fix switch points, turn disc again by 90°, until the bolt catches, then fasten tight the center screw **S**.

Levels of control vanes (illustration without cover)

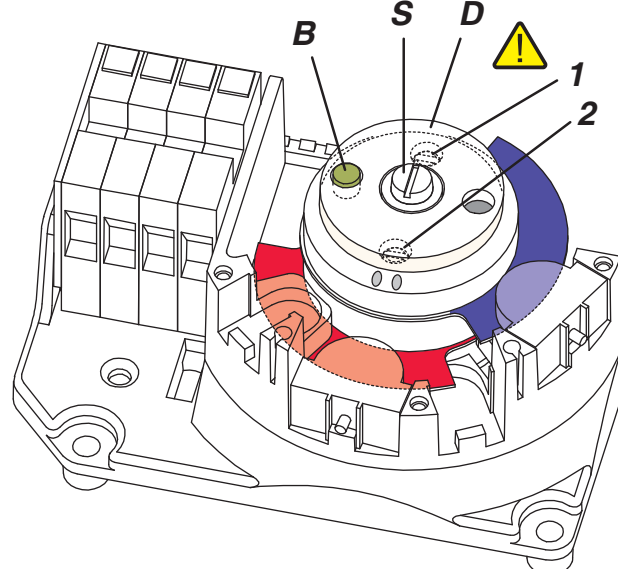



### 13 SYSTEM CONFIGURATION

The safety requirements in page 4 must be observed!

#### 13.1 Non-intrinsically safe operation

The SRI990 can be connected directly to the 4 to 20 mA output of the process control system or controller. Load RL approx. 300 Ohms.

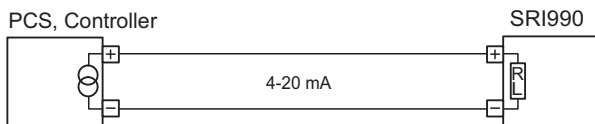

#### 13.2 Intrinsically-safe operation

The SRI990 can be connected directly to an intrinsically safe 4 to 20 mA output of the process control system or controller. If no intrinsically safe output is available, a suitable buffer amplifier or safety barrier with an intrinsically safe output must be connected. During intrinsically safe operation the connection must be checked for conformance to intrinsic safety before commissioning.

*Controller / process control system-output intrinsically safe:*

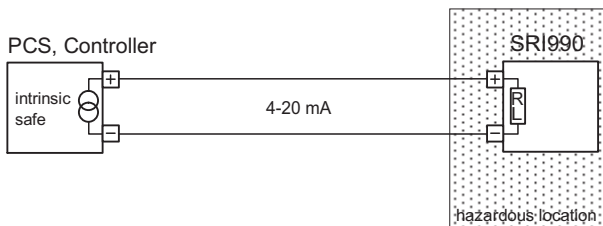

*Controller / process control system-output not intrinsically safe:*

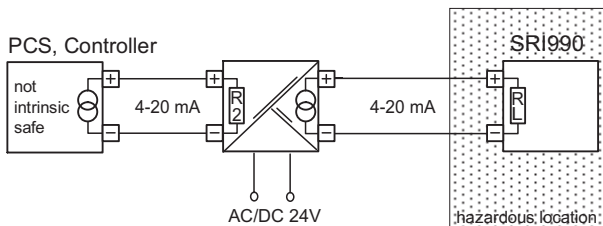

The following devices may be used:

Device	Input Load R2	Drives load at output	drives n *) SRI990
TV928	50 Ohms	600 Ohms	1 pc.
TV228	< 100 Ohms	700 Ohms	2 pcs.
II949	RL+200 Ohms	580 Ohms	1 pc.

\*) For split range

All components connected to the SRI990 in a hazardous location must be Ex-approved. The limits are not to be exceeded in any case. These limits are also valid for connection of other capacitances, inductances, voltages and currents. Additional options may have different limit values than the basic device. See Product Specification Sheet PSS EVE0107 A-(en) and/or Certificate of Conformity.

#### 13.3 Split range

If several actuators are to be controlled from an identical conduct variable and carry out full stroke only in a certain portion of this conduct variable, an individual SRI990 is to be provided for each actuator the zero and span of which can be set to the respectively desired partial range of the conduct variable.

The positioners are electrically switched in series. It is important that the permissible load of the process control system or controller is not exceeded (RL of an SRI990 approx. 300 Ohms). The output voltage (idle voltage) must be >8.5 V per connected positioner. The total line capacitance is not to exceed 1 µF.

*Example: 2-fold split range*

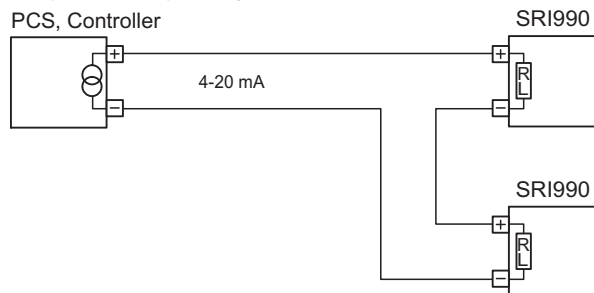

During intrinsically-safe operation, identical conditions as described in chapter 13.2 are valid.

Setting of the positioners is described in page 20.

