

Model 9600A Magnetic Flow Tube for hygienic and sanitary applications



The 9600A magnetic flow tube can be used with IMT30A, IMT31A and IMT33A magnetic flow transmitter.

- ▶ Robust stainless steel housing for hygienic and aseptic operation
- ▶ Fully suitable for CIP and SIP
- ▶ Typical food & beverage and pharmaceutical process connections and insertion lengths

Equipment should be installed, operated, serviced, and maintained only by qualified personnel.

No responsibility is assumed by Schneider Electric for any consequences arising from the use of this material.

1 Product features	3
<hr/>	
1.1 Sanitary and hygienic solution	3
1.2 Options	5
1.3 Measuring principle.....	7
2 Technical data	8
<hr/>	
2.1 Technical data.....	8
2.2 Dimensions and weights	13
2.3 Measuring accuracy	27
3 Model code	29
<hr/>	
4 Notes	31
<hr/>	

1.1 Sanitary and hygienic solution

The **9600A** electromagnetic flow tube is specifically designed to stay clean and sterile in compliance with the most stringent demands prevailing in the food & beverages and pharmaceutical industries. There are no crevices, gaps or blind spots and the flow tube offers full CIP/SIP possibilities. The flow tube is conform FDA food contact material requirements, for all wetted materials and is certified in accordance with EHEDG and 3A.

The flowmeter provides easy installation and commissioning and is available with the flow transmitter separate, or mounted directly on the flow tube. Therefore it can be installed in places difficult to access due to for example high temperatures or vibrations. The transmitter is also available in a stainless steel housing for applications when for example regular cleaning procedures with aggressive cleaning agents, may attack a standard polyurethane coating.

In addition to weld-end connections, this Schneider flow meter offers a large number of other hygienic connections, including DIN 11851, DIN 11864, clamp and SMS.

Because of its high accuracy, a precise measurement of the medium is possible enabling an accurate measurement of flows whether it is required for blending, dosing or batching. Furthermore its accuracy is maintained even in case of pulsating flows. When a medium has a low conductivity for example in case of glucose or fruit concentrates, the device continues to deliver an optimal performance.

Due to its reinforced liner the 9600A is an optimal solution for applications where high temperatures or vacuum impacts can occur. The certified hygienic construction is also available for larger diameters up to DN150, as volumes are increasing and larger pipe sizes are needed with fast increase in the industrial production of beer, wine, milk and other beverages.



Highlights

- Robust stainless steel housing for hygienic and aseptic operation
- PFA liner reinforced with embedded stainless steel grid for vacuum resistance
- High form stability for good accuracy even with high pressures
- Unique L-shaped gasket extends lifetime by preventing protrusion into measurement tube
- Wide choice of the electrode materials, even for extreme chemical applications.
- Simple and effective CIP / SIP
- Typical food and beverages and pharmaceutical process connections and insertion lengths
- Large diameter range DN2.5 up to DN150, to suit any F&B application
- All wetted materials are conform EC 1935/2004 and FDA food contact material regulation.
- Optimal hygienic performance conforming to EHEDG and 3A certification.
- Able to measure at low conductivity $\geq 1 \mu\text{S}/\text{cm}$ (for demin water $\geq 20 \mu\text{S}/\text{cm}$)
- Wide process temperature range $-40\dots 140^\circ\text{C}$ / $-40\dots +284^\circ\text{F}$

Industries

- Food & Beverages
- Pharmaceutical
- Cosmetics

Applications

- Exact blending, dosing and batching
- Beverages including soft drinks, beer, wine and fruits juices
- Milk and other dairy products
- Beverages containing solids (for example yoghurt containing cereals)
- Drugs, caustic sodas, acids, proteins, antibiotics
- CIP media including acids and caustic solutions
- For large-scale production plants with diameter up to DN150

1.2 Options



Reinforced PFA liner

The 9600A has an FDA conform PFA liner with an integrated stainless steel reinforcement that ensures vacuum resistance and long-term dimensional stability. The reinforced PFA liner makes sure that the flowmeter keeps its form stability even at high temperatures and very low pressure or vacuum. Therefore the 9600A remains its accuracy over time.

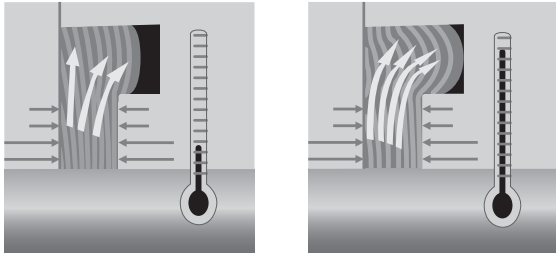

Unique gasket adapter concept

A special sealing concept for stainless steel adapters has been designed with support of TNO, a member of the European EHEDG organization. The sealing concept provides for a smooth and dimensionally stable measuring section between the two process connections. It prevents the gasket from expanding into the measuring tube because during CIP / SIP cleaning procedures, the gasket expands into an expansion chamber. This leads to a sharp sealing at the edge of the pipeline and a perfect transition into the measuring section. In addition, the gasket experiences less stress which results in a longer life time and reduced maintenance.



Hygienic Transmitter housing

The tube can be complemented with an IMT31A transmitter housing made of stainless steel 1.4404. This stainless steel transmitter housing for the Food and Beverage Industry is specially designed to ensure easy cleanability and resistance to regular rinsing with detergents

A mounting angle of 10 degrees avoids pooling and the special EPDM sealing all around, minimises crevices. Furthermore, the display is made entirely of polymer and can be used in "no glass" designated zones.

1.3 Measuring principle

An electrically conductive fluid flows inside an electrically insulated pipe through a magnetic field. This magnetic field is generated by a current, flowing through a pair of field coils.

Inside of the fluid, a voltage U is generated:

$$U = v * k * B * D$$

in which:

v = mean flow velocity

k = factor correcting for geometry

B = magnetic field strength

D = inner diameter of flowmeter

The signal voltage U is picked off by electrodes and is proportional to the mean flow velocity v and thus the flow rate Q . A signal transmitter is used to amplify the signal voltage, filter it and convert it into signals for totalizing, recording and output processing.

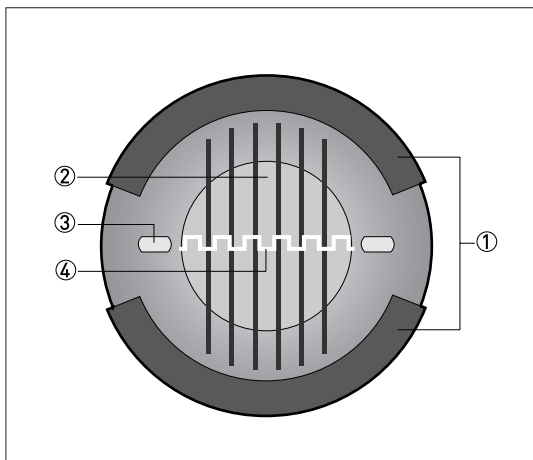

Figure 1-1: Measuring principle

- ① Field coils
- ② Magnetic field
- ③ Electrodes
- ④ Induced voltage (proportional to flow velocity)

2.1 Technical data

- *The following data is provided for general applications. If you require data that is more relevant to your specific application, please contact us or your local sales office.*
- *Additional information (certificates, special tools, software,...) and complete product documentation can be downloaded free of charge from the website.*

Measuring system

Measuring principle	Faraday's law of induction
Application range	Electrically conductive fluids
Measured value	
Primary measured value	Flow velocity
Secondary measured value	Volume flow

Design

Features	Hygienic design
	Stainless steel housing
	Food & beverage and pharmaceutical process connections
Modular construction	The measurement system consists of a flow tube and a signal transmitter. It is available as compact and as separate version.
Compact version	With signal transmitter: IMT30A
	With signal transmitter: IMT31A
	With signal transmitter: IMT33A
Remote version	In wall (W) mount version with signal transmitter: IMT30A
	In wall (W) mount version with signal transmitter: IMT31A
	In field (H) or wall (N) version with signal transmitter: IMT33A H or N
Nominal diameter	DN2.5...150 / 1/10" ...6"
Measuring range	-12...+12 m/s / -40...+40 ft/s

Measuring accuracy

Maximum measuring error	Depending on signal transmitter and DN size.
	IMT30A: down to 0.5% of the measured value ± 1 mm/s.
	IMT31A: down to 0.3% of the measured value ± 1 mm/s for DN10...150 (3/8...6"). down to 0.4% of the measured value ± 1 mm/s for DN2.5...6 (1/10...1/4").
	IMT33A: down to 0.2% of the measured value ± 1 mm/s for DN10...150 (3/8...6"). down to 0.3% of the measured value ± 2 mm/s for DN2.5...6 (1/10...1/4").
	Optional:
	Optimised accuracy for IMT30A and IMT31A. For more details on optimised accuracy, see the concerning signal transmitter documentation.
	The additional typical measuring deviation for the current output is $\pm 10 \mu\text{A}$.
	The maximum measuring error depends on the installation conditions. For detailed information refer to <i>Measuring accuracy</i> on page 27.
Repeatability	$\pm 0.1\%$ of MV, minimum 1 mm/s
Long term stability	$\pm 0.1\%$ of MV

Operating conditions

Temperature	
Process temperature	Separate flow tube: $-40\dots+140^\circ\text{C}$ / $-40\dots+284^\circ\text{F}$
	Compact with IMT33A transmitter: $-40\dots+140^\circ\text{C}$ / $-40\dots+284^\circ\text{F}$
	Compact with IMT30A and IMT31A transmitter: $-40\dots+120^\circ\text{C}$ / $-40\dots+248^\circ\text{F}$ at an ambient temperature $\leq 40^\circ\text{C}$ / 104°F
	For ISO 2852 and Tri-clamp versions: $-40\dots+120^\circ\text{C}$ / $-40\dots+248^\circ\text{F}$
	For Ex versions different temperatures are valid. Please check the relevant Ex documentation for details.
Ambient temperature	$-40\dots+65^\circ\text{C}$ / $-40\dots+149^\circ\text{F}$
	IFC 100 stainless steel version: $-40\dots+60^\circ\text{C}$ / $-40\dots+140^\circ\text{F}$
Storage temperature	$-50\dots+70^\circ\text{C}$ / $-58\dots+158^\circ\text{F}$
Pressure	
Ambient pressure	Atmospheric
Nominal flange pressure	For detailed information refer to <i>Dimensions and weights</i> on page 13.
Vacuum load	0 mbar / 0 psi

Chemical properties	
Physical condition	Electrical conductive liquids
Electrical conductivity	Standard: $\geq 1 \mu\text{S/cm}$
	Water: $\geq 20 \mu\text{S/cm}$
Permissible gas content (volume)	IMT30A: $\leq 3\%$
	IMT31A: $\leq 3\%$
	IMT33A: $\leq 5\%$
Permissible solid content (volume)	IMT30A: $\leq 10\%$
	IMT31A: $\leq 10\%$
	IMT33A: $\leq 70\%$

Installation conditions

Installation	Assure that the flow tube is always fully filled.
	For detailed information refer to the manual of the flow tube and signal transmitter.
Flow direction	Forward and reverse
	Arrow on flow tube indicates positive flow direction.
Inlet run	$\geq 5 \text{ DN}$
Outlet run	$\geq 2 \text{ DN}$
Dimensions and weights	For detailed information refer to <i>Dimensions and weights</i> on page 13.

Materials

Tube housing	DN2.5...15: stainless steel Duplex (1.4462)
	DN25...150: stainless steel AISI 304 (1.4301)
Measuring tube	Stainless steel AISI 304 (1.4301)
Adapters	Stainless steel AISI 316 L (1.4404)
Liner	PFA
Connection box (F-version only)	Standard:
	Aluminum with a standard coating
	Option:
	Stainless steel AISI (1.4408)
Electrodes	Standard:
	Hastelloy® C
	Option:
	Hastelloy® B2, platinum, stainless steel, tantalum, titanium
Gaskets	Standard:
	EPDM
	FDA recommends EPDM gaskets only if medium $\leq 8\%$ fat.
	Option:
	Silicone (non-Ex only)

Process connections

DIN EN 10357 / DIN 11850 row 2 / 11866 row A	DN2.5...150
DIN 11851	DN2.5...150
DIN 11864-2A flange with notch	DN25...150
DIN 32676	DN25...150
ISO 2037	DN2.5...150
ISO 2852	DN2.5...150
SMS 1146	DN2.5...100
Tri Clamp	1/10"...6"
Note: tube diameters < DN10 have DN10 connections, which means the tube diameter is smaller.	

Electrical connections

Signal cable	
Type A (DS)	Standard cable, double shielded. Max. length: 600 m / 1950 ft (dep. on electrical conductivity and measuring tube). See documentation of the transmitter for more information.
Type B (BTS)	Optional cable, triple shielded. Max. length: 600 m / 1950 ft (dep. on electrical conductivity and measuring tube). See documentation of the transmitter for more information.

Approvals and certificates

CE	
This device fulfills the statutory requirements of the EU directives. The manufacturer certifies successful testing of the product by applying the CE mark.	
	For full information of the EU directives and standards and the approved certifications, please refer to the EU Declaration of Conformity or the website of the manufacturer.
Hazardous areas	
ATEX	Please check the relevant Ex documentation for details.
	Compact version with IMT33A 4 transmitter:
	II 2 G, II D, II 2 (1) G
	Remote (F) version:
	II 2 G, II 2 D
FM	In combination with IMT33A 4 or H transmitter:
	Class I, Div. 2, Groups A, B, C and D
	Class II, Div. 2, Groups F and G
	Class III, Div. 2, Groups F and G
	Only available for DN2.5...15
CSA	In combination with IMT33A 4 or H transmitter:
	Class I, Div. 2, Groups A, B, C and D
	Class II, Div. 2, Groups F and G
	Class III, Div. 2, Groups F and G
	Only available for DN2.5...15
Other approvals and standards	
Protection category acc. to IEC 60529	Standard
	IP 66/67, NEMA 4/4X/6
	Option (F version only)
	IP 68 field, NEMA 6P
	IP 68 factory, NEMA 6P
	IP 68 is only available for separate design and with a stainless steel connection box.
	Option IP69 IP 67/69 is available for connection box and IMT31A in stainless steel.
Hygienic	3A approved
	EHEDG
Shock test	IEC 60068-2-27
	30 g for 18 ms
Vibration test	IEC 60068-2-64
	f = 20...2000 Hz, rms = 4.5 g, t = 30 min.

2.2 Dimensions and weights

DIN EN 10357/ DIN 11850 (row 2 or DIN 11866 row A)

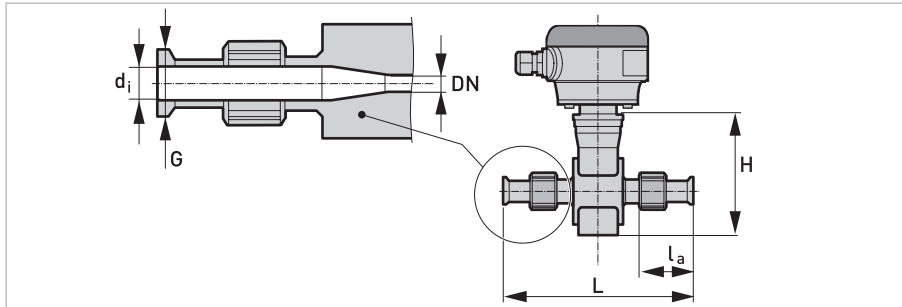

DN2.5...10 screwed adapter with DN10 process connections / DN15 screwed adapter

Nominal size		Dimensions [mm]						Approx. weight [kg]
		Adapter			Flowmeter			
DN	PN	d_i	G	l_a	L	H	W	
2.5...10	40	10	13	32	180	120	44	1.5
15	40	16	19	32	180	120	44	1.5

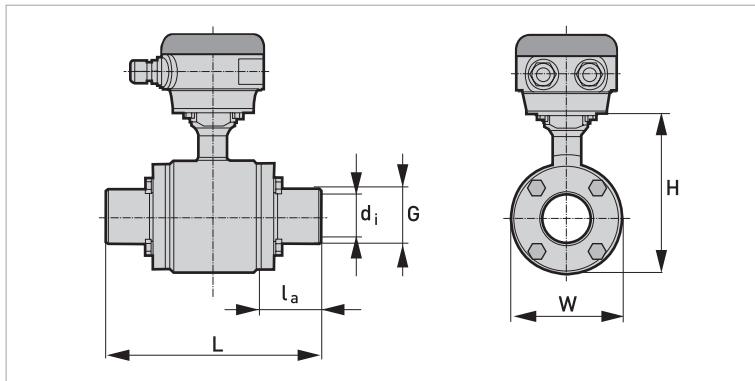

DN25...150 bolted adapter

Nominal size		Dimensions [mm]						Approx. weight [kg]
		Adapter			Flowmeter			
DN	PN	d_i	G	l_a	L	H	W	
25	40	26	29	20.6	132.6	128	89	3
40	40	38	41	61.3	220	153	114	5.3
50	25	50	53	61.3	220	153	114	6.8
65	25	66	70	41.8	220	180	141	10.9
80	25	81	85	66.8	280	191	152	11.2
100	16	100	104	59.3	280	242	203	18.4
125	10	125	129	66.3	319	258	219	29.5
150	10	150	154	64.3	325	293	254	44.3

DIN 11851

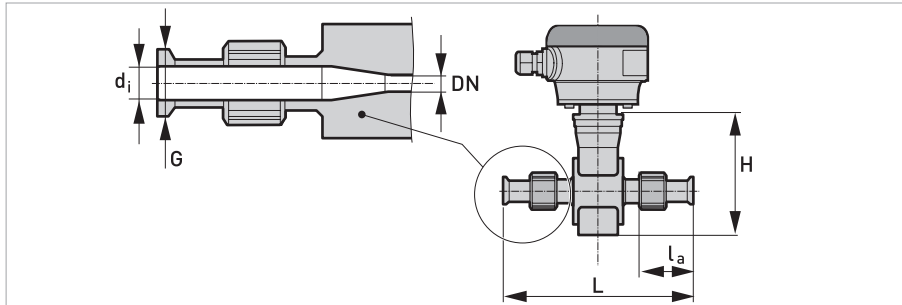

DN2.5...10 screwed adapter with DN10 process connections / DN15 screwed adapter

Nominal size		Dimensions [mm]						Approx. weight [kg]
		Adapter			Flowmeter			
DN	PN	d _i	G	l _a	L	H	W	
2.5...10	40	10	Rd 28 x 1/8"	53.1	214	142	44	1.5
15	40	16	Rd 34 x 1/8"	53.1	214	142	44	1.5

DIN 11851

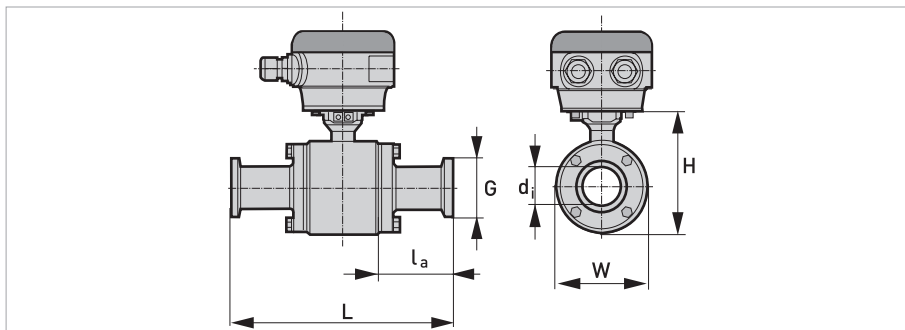

DN25...150 bolted adapter

Nominal size		Dimensions [mm]						Approx. weight [kg]
		Adapter			Flowmeter			
DN	PN	di	G	la	L	H	W	
25	40	26	Rd 52 x 1/6"	49.3	190	128	89	3.2
40	40	38	Rd 65 x 1/6"	91.3	280	153	114	5.5
50	25	50	Rd 78 x 1/6"	93.3	284	153	114	5.3
65	25	66	Rd 95 x 1/6"	77.8	292	180	141	10
80	25	81	Rd 110 x 1/4"	107.8	362	191	152	12.5
100	16	100	Rd 130 x 1/4"	109.3	380	242	203	21.8
125	10	On request						
150	10	On request						

DIN 11864-2A

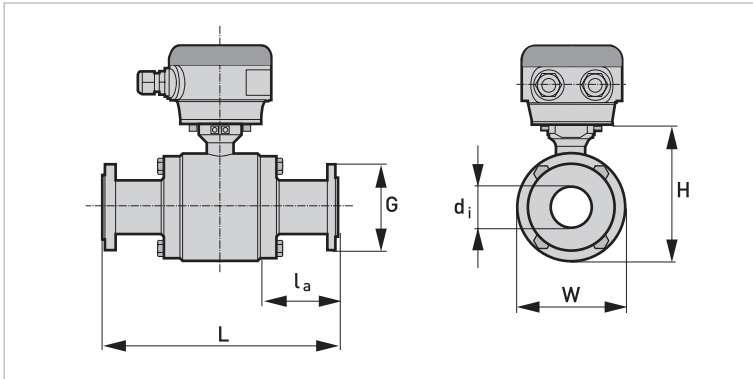

DN25...150 bolted adapter

Nominal size		Dimensions [mm]						Approx. weight [kg]
		Adapter			Flowmeter			
DN	PN	d _i	G	l _a	L	H	W	
25	40	26	70	45.8	183	128	89	4.4
40	25	38	82	83.3	264	153	114	7.5
50	25	50	94	83.3	264	153	114	9
65	25	66	113	63.8	264	180	141	14.5
80	25	81	133	122.8	392	191	152	18.6
100	16	100	159	115.3	392	242	203	28.2
125	10	125	183	121	429	259	219	35
150	10	150	213	127	450	294	254	52

DIN 32676

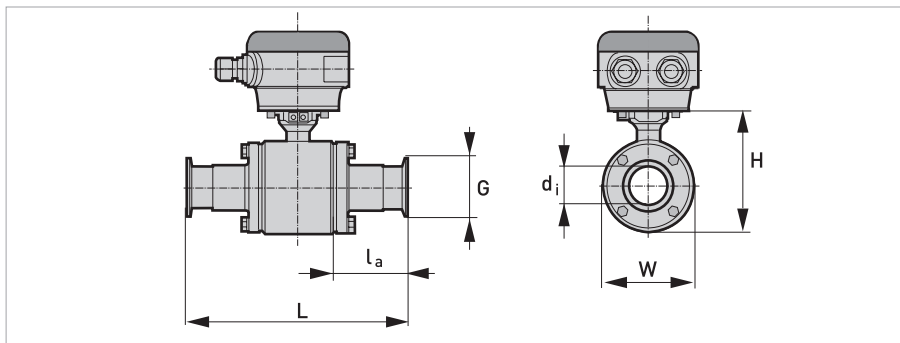

DN25...150 bolted adapter

Nominal size		Dimensions [mm]						Approx. weight [kg]
		Adapter			Flowmeter			
DN	PN	d _i	G	l _a	L	H	W	
25	16	26	50.5	41.8	175	128	89	3.2
40	16	38	50.5	80.8	259	153	114	5.5
50	16	50	64	80.8	259	153	114	5.3
65	16	66	91	67.8	272	180	141	10
80	16	81	106	92.8	332	191	152	12.5
100	16	100	119	85.3	332	242	203	21.8
125	16	125	155	90	366	259	219	30
150	16	150	213	127	450	294	254	45

ISO 2037

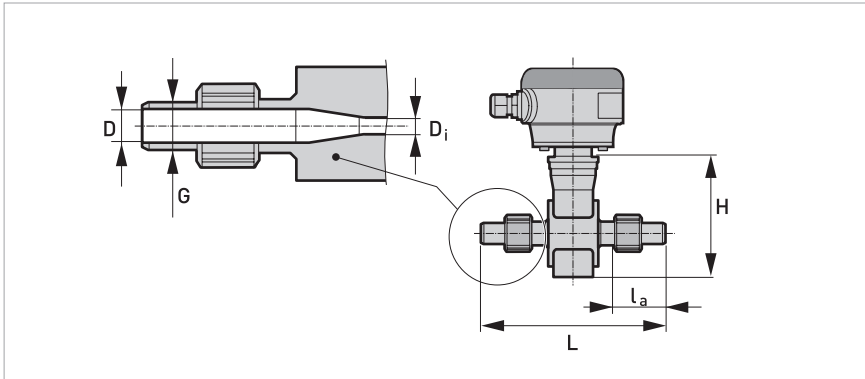

DN2.5...10 screwed adapter with DN10 process connections / DN17.2 screwed adapter

Nominal size		Dimensions [mm]						Approx. weights [kg]
		Adapter			Flowmeter			
DN	PN	d_i	G	l_a	L	H	W	
2.5...12	40	10	15	32	180	142	44	1.5
17.2	40	16	21	32	180	142	44	1.5

ISO 2037

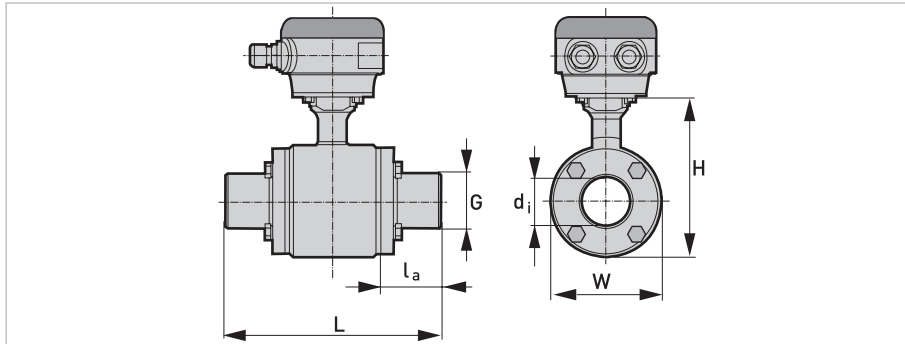

DN25...150 bolted adapter

Nominal size		Dimensions [mm]						Approx. weights [kg]
		Adapter			Flowmeter			
DN	PN	d_i	G	l_a	L	H	W	
25	40	22.6	31	20.6	132.6	128	89	3
38	40	38	43	61.3	220	153	114	5.3
51	25	49	55	61.3	220	153	114	5
63.5	25	60.3	71	41.8	220	180	141	9
76.1	25	72.9	86	66.8	280	191	152	10.8
101.6	16	97.6	105	59.3	280	242	203	18.4
114.3	10	110.3	130	66.3	319	258	219	29.5
139.7	10	135.7	156	64.3	325	293	254	44.3

ISO 2852

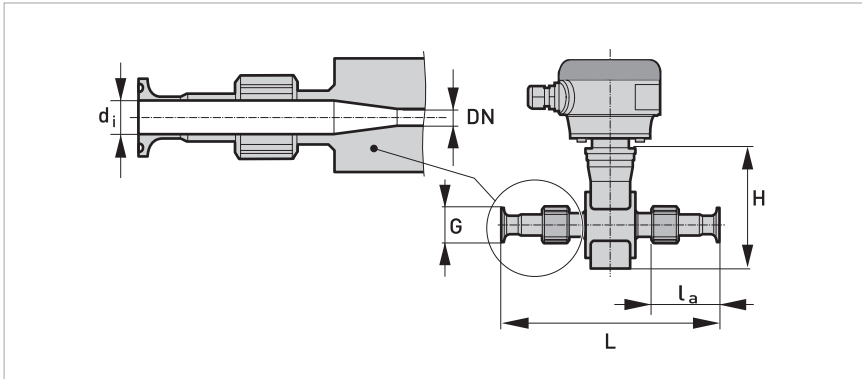

DN2.5...10 screwed adapter with DN10 process connections / DN17.2 screwed adapter

Nominal size			Dimensions [mm]						Approx. weight
DN	[Inch]	PN	Adapter			Flowmeter			
DN	[Inch]	PN	d_i	G	l_a	L	H	W	[kg]
2.5...10	1/10"...3/8"	16	10	34	51.6	219	142	44	1.8
17.2	1/2"	16	16	34	51.6	219	142	44	1.8

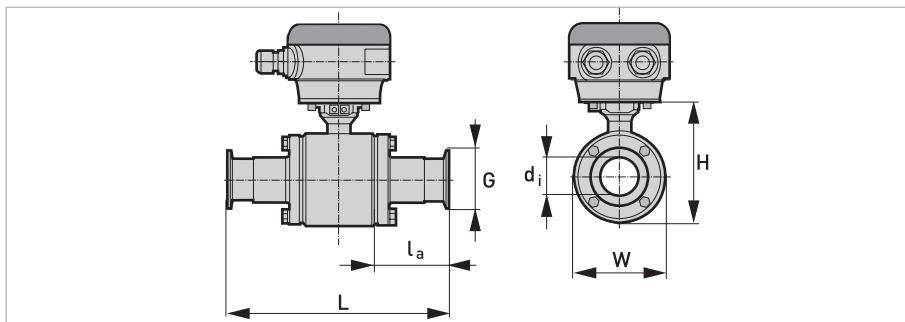

DN25...150 bolted adapter

Nominal size			Dimensions [mm]						Approx. weight [kg]
			Adapter			Flowmeter			
DN	[Inch]	PN	d_i	G	l_a	L	H	W	
25	1"	16	22.6	50.5	41.8	175	128	89	3.3
38	1.5"	16	35.6	50.5	87.8	273	153	114	5.4
50	2"	16	48.6	64	87.8	273	153	114	5.2
63.5	2.5"	10	60.3	77.5	68.3	273	180	141	9.5
76.1	3"	10	72.9	91	93.3	333	191	152	11.2
101.6	4"	8	97.6	119	85.8	333	242	203	19.1
114.3	5"	5	110.3	211	90	366	259	219	30
139.7	6"	5	135.7	246	90	376	294	254	45

Tri Clamp

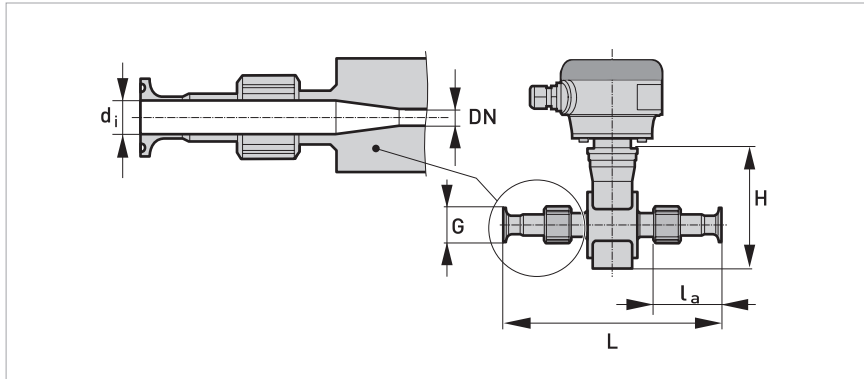

DN1/10...1/2" screwed adapter

Nominal size		Dimensions [inch]						Approx. weight [kg]
		Adapter			Flowmeter			
DN	PN	d_i	G	l_a	L	H	W	
1/10"...3/8"	20	0.37	0.98	1.97	8.5	5.59	1.73	1.5
1/2"	20	0.62	0.98	1.97	8.5	5.59	1.73	1.5

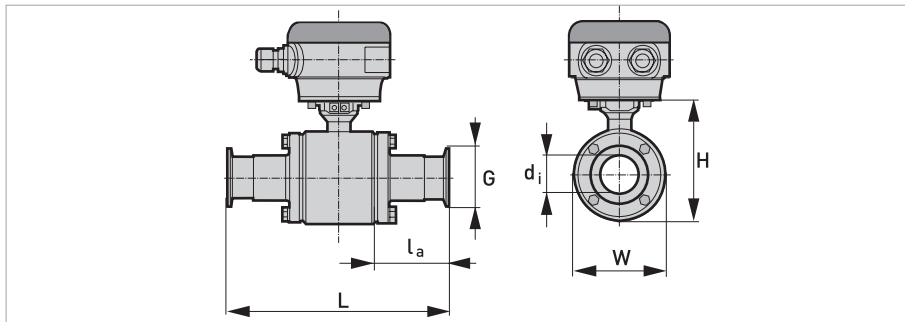

DN1...6" bolted adapter

Nominal size		Dimensions [inch]						Approx. weight [kg]
		Adapter			Flowmeter			
DN	PN	d_i	G	l_a	L	H	W	
1"	20	0.85	1.98	1.02	5.64	5.04	3.5	3.2
1½"	20	1.35	1.98	3.46	10.75	6.02	4.49	5.5
2"	20	1.85	2.52	3.46	10.75	6.02	4.49	5.3
2½"	20	2.35	3.05	2.69	10.75	7.09	5.55	10
3"	20	2.85	3.54	3.68	13.11	7.52	5.98	12.5
4"	12	3.83	4.68	3.38	13.11	9.53	7.99	21.8
5"	-	4.78	5.69	3.54	14.43	10.20	8.62	30
6"	-	5.78	6.57	3.62	14.80	11.57	10.00	45

SMS 1146 Adapter

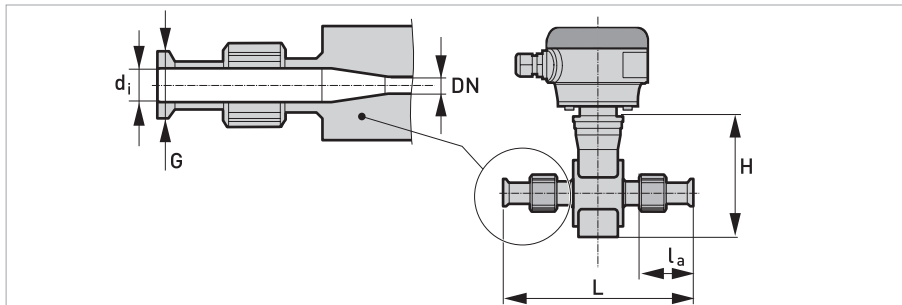

DN2.5...10 screwed adapter with DN10 process connections / DN15 screwed adapter

Nominal size		Dimensions [mm]						Approx. weight [kg]
		Adapter			Flowmeter			
DN	PN	d _i	G	l _a	L	H	W	
2.5	39	10	Rd 40-6	53	226	128	44	2
4	39	10	Rd 40-6	53	226	128	44	2
6	39	10	Rd 40-6	53	226	128	44	2
10	6	10	Rd 40-6	53	226	128	44	2
15	6	10	Rd 40-6	53	226	128	44	2

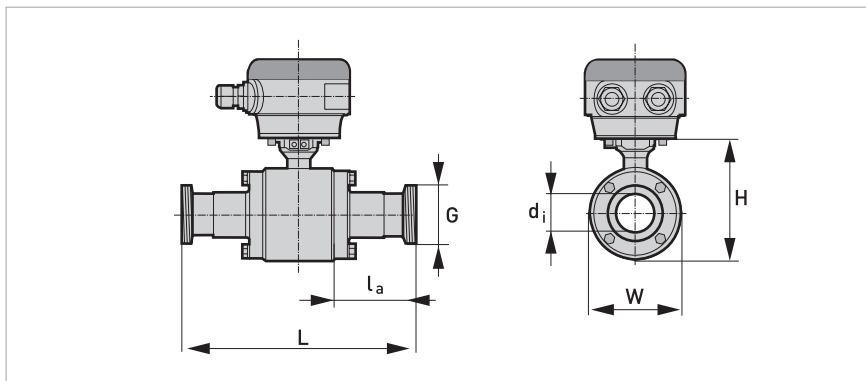

DN25...100 bolted adapter

Nominal size		Dimensions [mm]						Approx. weight [kg]
		Adapter			Flowmeter			
DN	PN	d_i	G	l_a	L	H	W	
25	6	22.6	Rd 40-6	28.1	147.6	128	89	3.2
38	6	35.5	Rd 60-6	54	262	153	114	5.7
51	6	48.6	Rd 70-6	84.3	266	153	114	5.4
63.5	6	60.3	Rd 85-6	69.8	276	180	141	9.9
76	6	72.9	Rd 98-6	99.8	346	191	152	12.1
100	6	97.6	Rd 132-6	44	336	242	203	21.9

2.3 Measuring accuracy

Every electromagnetic flowmeter is calibrated by direct volume comparison. The wet calibration validates the performance of the flowmeter under reference conditions against accuracy limits.

The accuracy limits of electromagnetic flowmeters are typically the result of the combined effect of linearity, zero point stability and calibration uncertainty.

Reference conditions

- Medium: water
- Temperature: +5...+35°C / +41...+95°F
- Operating pressure: 0.1...5 barg / 1.5...72.5 psig
- Inlet section: \geq DN
- Outlet section: \geq DN

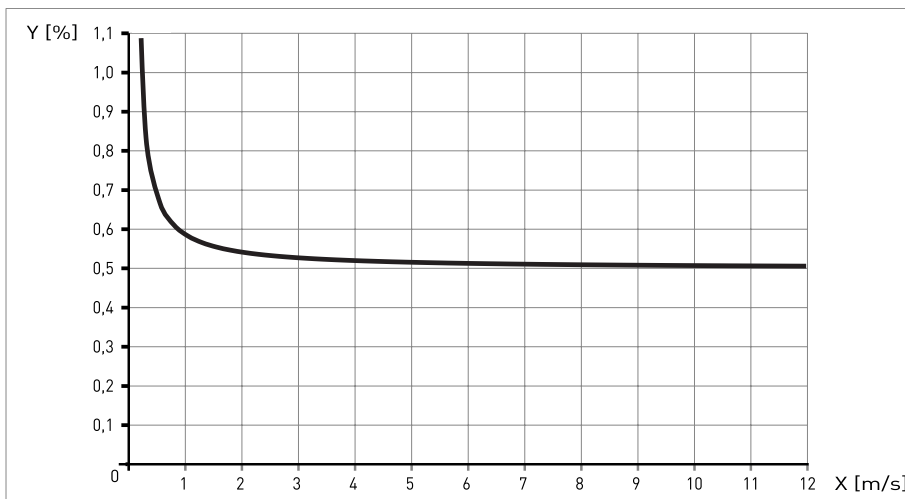

Figure 2-1: Flow velocity vs. accuracy

X [m/s] : flow velocity

Y [%]: deviation from the actual measured value (mv)

Compact with IMT30A	Accuracy	Curve
DN10...150 3/8...6"	0.5% of MV + 1 mm/s	

Optionally for IMT30A; extended calibration at 2 points for optimised accuracy.

For more details on optimised accuracy, see the concerning signal transmitter documentation.

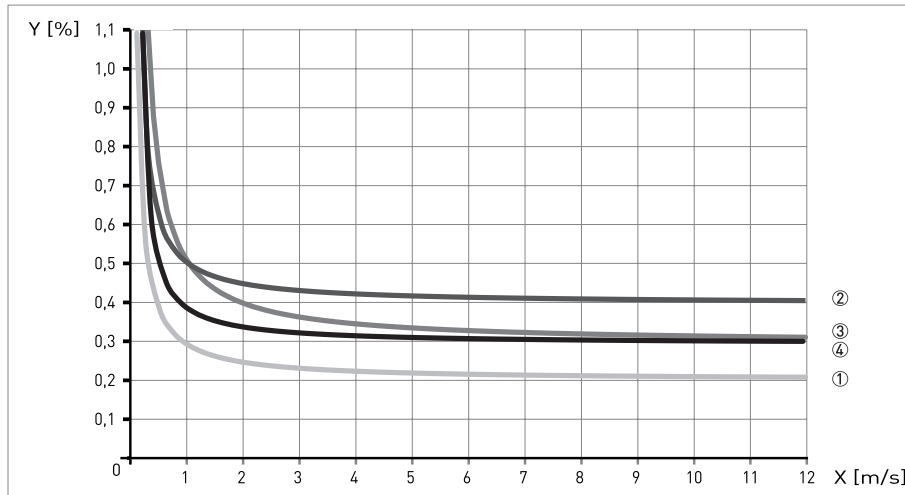

Figure 2-2: Flow velocity vs. accuracy
 X [m/s] : flow velocity
 Y [%]: deviation from the actual measured value (mv)

Compact with IMT33A	Accuracy	Curve
DN2.5...6 1/10...1/4"	0.3% of MV + 2 mm/s	③
DN10...150 3/8...6"	0.2% of MV + 1 mm/s	①

Compact with IMT31A	Accuracy	Curve
DN2.5...6 1/10...1/4"	0.4% of MV + 1 mm/s	②
DN10...150 3/8...6"	0.3% of MV + 1 mm/s	④

*Optionally for IMT31A; extended calibration at 2 points for optimised accuracy.
 For more details on optimised accuracy, see the concerning signal transmitter documentation.*

Model	Description
	Schneider Electric Model 9600A Magnetic Flow Tube
960TA 960SA 960QA 963EA 96HAA 9601A 961HA 9602A 962HA 9603A 9604A 9605A 9606A	Nominal diameter and liner DN 2.5...1/10" - PFA DN 4...1/8" - PFA DN 6... 1/4" - PFA DN 10...3/8" - PFA DN 15...1/2" - PFA DN 25...1 - PFA DN 40...1 1/2" - PFA DN 50...2" - PFA DN 65...2 1/2" - PFA DN 80...3" - PFA DN 100...4" - PFA DN 125...5" - PFA DN 150...6" - PFA
-H -K -L -N -P -S -T -U	Nominal pressure and connection DIN 11851 - dairy screw connection SMS 1145 - dairy screw connection ISO 2852 - clamp connection DIN 32676 - clamp connection Tri CLAMP - clamp connection DIN 11850 - weld-end connection ISO 2037 - weld-end connection DIN 11864-2A - flange connection
0 1 3 5 A C	Ex version Non Ex Ex Zone 1 IMT33A compact [DN 2.5...80] & field [DN 25...80] & IMT31A wall [25...80] Ex Zone 2 (IMT33A compact and field) FM Class I DIV 2 (IMT33A Field [DN 2.5...15]) cCSAus OL (IMT33A compact / field / wall & IMT31A compact / wall) CSA Class I DIV 2
1 2 3 4 5 6 A B C	System design 1 Compact/Integral design with aluminum transmitter housing/ cable connections at the transmitter 2 Compact/Integral design with stainless steel transmitter housing/ cable connections at the transmitter 3 Modular / without 4 Separate design with aluminum connection box / 1/2" NPT cable connections 5 Separate with aluminum connection box / PF 1/2" cable connections 6 Separate design with aluminum connection box / M20 x 1.5 A cable connections A Separate design with stainless steel connection box / 1/2" NPT cable connections B Separate design with stainless steel connection box / PF 1/2" cable connections C Separate design with stainless steel connection box / M20 x 1.5 cable connections
0 3 4 C D E F K L	Transmitter model Without / modular IMT31A (compact design) IMT31A (wall mount version) IMT33A (compact design) IMT33A (field mount version) IMT33A (wall mount version) IMT33A (rack mount version) IMT30A (compact design) (DN 10...150 3/8"...6") IMT30A (wall mount version) (DN 10...150 3/8"...6")
0	Mounting Material Without
0 D	Grounding ring material Without / L-profile O-ring EPDM (aseptical connection) Without / L-profile O-ring silicone (aseptical connection)

Model	Description
	Electrodes (fixed)
1	St.Steel 1.4571 / 316Ti (DN 2,5...15 1/10" ...1/2")
3	Hastelloy C4 (DN 2,5...15 1/10" ...1/2")
4	Hastelloy B2 (DN 2,5...15 1/10" ...1/2")
5	Tantalum (DN 2,5...15 1/10" ...1/2")
6	Titanium
7	Platinum (wetted parts) (DN 2,5...15 1/10" ...1/2")
A	St.Steel 1.4404/316L (DN 25...100 1" ...4")
B	Hastelloy C22 DN 2,5...150 1/10" ...6")
	Protection class / dimension (face-to-face)
0	IP 66 67 / standard
1	IP 68 Filled / standard (with stainless steel connection box)
2	IP 68 Factory / standard (with stainless steel connection box)
	Cable
0	Compact - without / separate DS
1	Separate BTS
2	Separate LIYCY (only for FM / CSA Class 1 DIV 2)
Y	Without
	Cable length
0	Compact - none / separate - 5 m 15 ft
1	10 m 30 ft
2	15 m 45 ft
3	20 m 60 ft
4	25 m 75 ft
5	30 m 90 ft
6	40 m 120 ft
7	50 m 150 ft
8	100 m 300 ft
Y	Without
	Calibration
0	Standard
2	316/1.4401 tag plate (120 x 46 mm)
3	316/1.4401 tag plate (67 x 25 mm)
	Construction requirements
0	Standard
	QA / QC requirements
0	Standard
	Ratio of CT-calibration
0	Standard, R=80



ORDERING INSTRUCTIONS

1. Model Number.
2. Flow Data:
 - a. Maximum, minimum, and normal flow rate.
 - b. Fluid composition and viscosity at operating temperatures.
 - c. Fluid density or relative density (specific gravity).
 - d. Maximum, minimum and normal operating temperatures.
 - e. Maximum, minimum and normal operating pressures.
 - f. Mating pipe schedule.
 - g. Type and location (distance) of upstream disturbance.
3. Calibration Information (analog output only); maximum flow rate 20 mA output.
4. Electric Classification.
5. Optional Selections and Accessories.
6. Customer Tag Data.

FLOWEXPERTPRO SIZING APPLICATION

Website
www.FlowExpertPro.com



App Store (Apple®)



Google Play™ Store
(Android®)



ADDITIONAL PRODUCTS

These product lines offer a broad range of measurement and instrument products, including solutions for pressure, flow, analytical, temperature, positioning, controlling and recording.

For a list of these offerings, visit our website at:

www.se.com

Schneider Electric Systems USA, Inc. Global Customer Support
38 Neponset Avenue Inside U.S.: 1-866-746-6477
Foxboro, MA 02035 Outside U.S.: 1-508-549-2424
United States of America <https://pasupport.schneider-electric.com>
<http://www.se.com>

Copyright 2019 Schneider Electric Systems USA, Inc.
All rights reserved.

The Schneider Electric brand and any trademarks of Schneider Electric SE or its subsidiaries are the property of Schneider Electric SE or its subsidiaries.
All other trademarks are the property of their respective owners.

