

SRI990 Analog Positioner

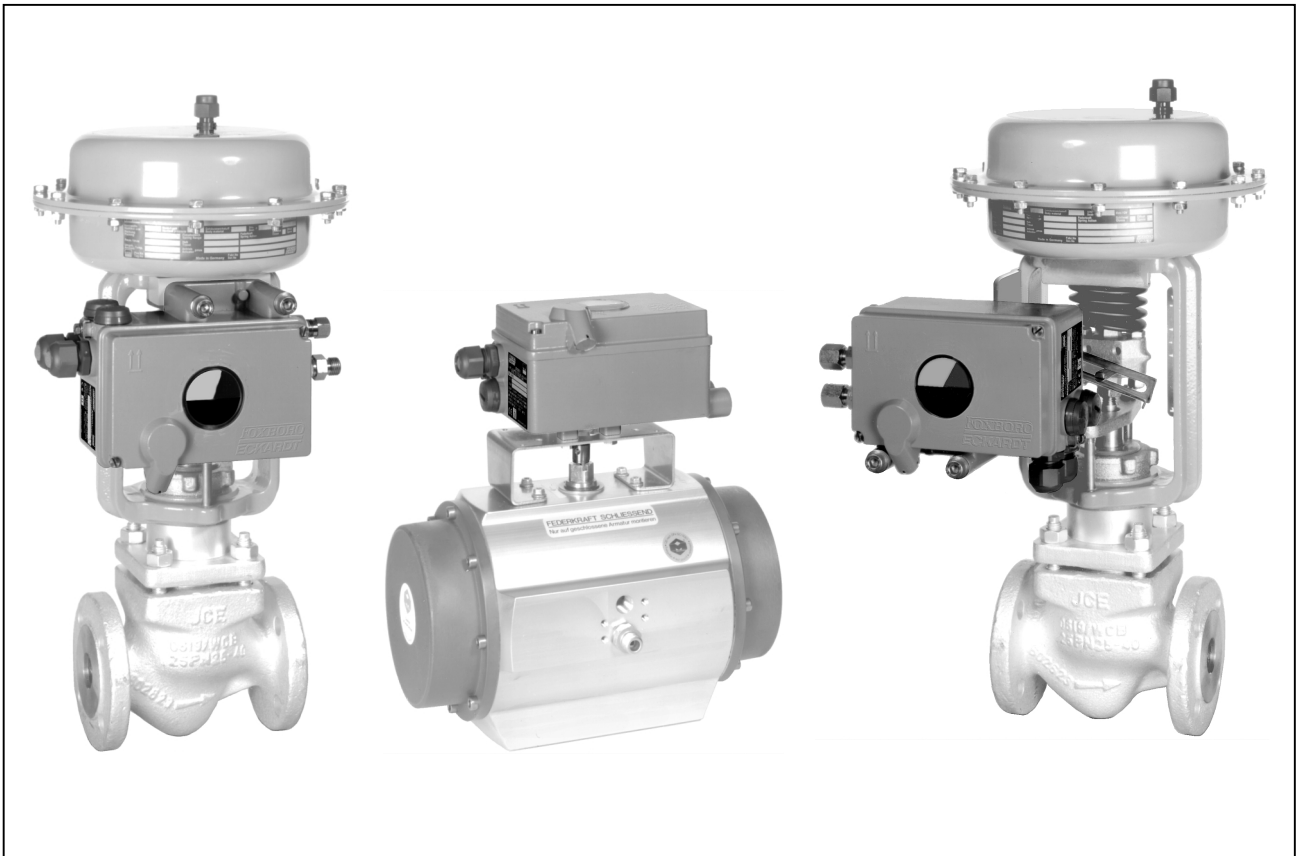

The analog Positioner SRI990 with analog input 4 to 20 mA is designed to operate pneumatic valve actuators. It offers an easy adjustment by means of switches and potentiometers. The modular structure of the POSYS positioner series enables conversion from an analog to a “digital” or “intelligent” positioner by exchanging the electronics.

FEATURES

- Configuration by means of switches and potentiometers
 - Load 300
 - Low air consumption
 - Stroke 8 to 120 mm (0.3 to 4.7 inch)
 - Angle range up to 95 degree
 - Supply air pressure up to 6 bar (90 psig)
 - Single acting or double acting
 - Mechanical travel indicator
 - Reverse polarity protection and interlock diode
 - Attachment to stroke actuators directly or according to IEC 534 part 6 (NAMUR)
 - Attachment to rotary actuators according to VDI/VDE 3845
 - Failsafe position in case of failure of electronics
 - Protection class IP 65 and NEMA 4X
 - Explosion protection: EEx ia IIC according to CENELEC or “Intrinsic safety” according to FM and CSA
- Additional equipments (compatible to SRD991/992):
- Integrated inductive limit switches, independent of device electronics
- Accessories (compatible to SRD991/SRD992):
- Gauge attachment for supply air and outputs
 - Booster relay

TABLE OF CONTENTS

| CHAP: CONTENT | PAGE | CHAP: CONTENT | PAGE |
|-----------------|--|---------------|------|
| 1 | METHOD OF OPERATION | 3 | |
| 1.1 | General | 3 | |
| 1.2 | Block diagram | 3 | |
| 1.3 | Operation. | 3 | |
| 1.4 | Safety Requirements | 4 | |
| 2 | LABELS | 5 | |
| 3 | DESIGN. | 6 | |
| 3.1 | Pneumatic accessories | 7 | |
| 4 | MOUNTING TO LINEAR ACTUATORS | 8 | |
| 4.1 | NAMUR Mounting (left hand) | 8 | |
| 4.2 | NAMUR Mounting (right hand) | 10 | |
| 4.3 | Direct Mounting | 12 | |
| 5 | MOUNTING TO ROTARY ACTUATORS. | 14 | |
| 6 | PNEUMATIC CONNECTIONS. | 16 | |
| 7 | ELECTRICAL CONNECTION | 17 | |
| 8 | START-UP | 18 | |
| 8.1 | General | 18 | |
| | Setting of - | | |
| 8.2 | - Direction of rotation of feedback shaft | 19 | |
| 8.3 | - Input Signal Range. | 20 | |
| | Split Range | 20 | |
| 8.4 | - Gain (G) | 21 | |
| 8.5 | - Zero (ZERO) and Span (S). | 21 | |
| 8.6 | - Damping (D) | 21 | |
| 8.7 | - Travel indicator. | 21 | |
| 8.8 | Air reducing throttles. | 22 | |
| 8.9 | Basic adjustment of electronics. | 22 | |
| 8.10 | Pneumatic test. | 22 | |
| 9 | DECOMMISSIONING | 22 | |
| 10 | TROUBLE-SHOOTING GUIDE | 23 | |
| 11 | MAINTENANCE | 24 | |
| 11.1 | General | 24 | |
| 11.2 | Supply filter replacement | 24 | |
| 11.3 | Removal of the electronics unit. | 24 | |
| 11.3.1 | Conversion of positioner. | 24 | |
| 11.4 | Replacement of mechanical and pneumatic units | 25 | |
| 11.4.1 | Amplifier replacement. | 25 | |
| 11.4.2 | Preamplifier replacement | 25 | |
| 11.4.3 | IP-module replacement | 25 | |
| 11.4.4 | Feedback unit replacement | 25 | |
| 12 | OPTION "Limit switch" | 26 | |
| APPENDIX | | | |
| 13 | SYSTEM CONFIGURATION | 27 | |
| | DIMENSIONS | 28 | |

1 METHOD OF OPERATION

1.1 General

The intelligent positioner SRD991 **1** and the pneumatic actuator **2** form a control loop with the setpoint value w (from master controller or control system), the output pressure y and the position x of the actuator on valve **3**.

The positioner can be attached to both linear actuators and rotary actuators.

Actuators with spring force are controlled by a single acting positioner. Actuators without spring force are controlled by a double acting positioner. The positioner can be operated by means of switches and potentiometers.

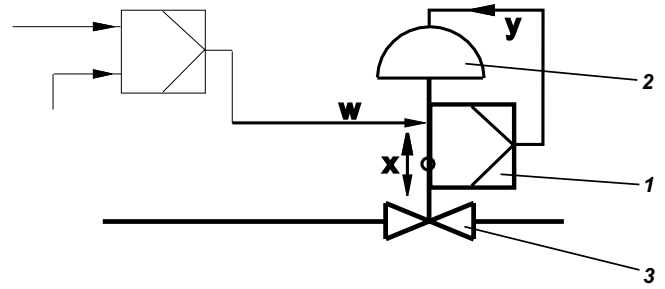

For the supply air, we recommend the FOXBORO ECKARDT FRS923 filter regulator.

1.2 Block diagram

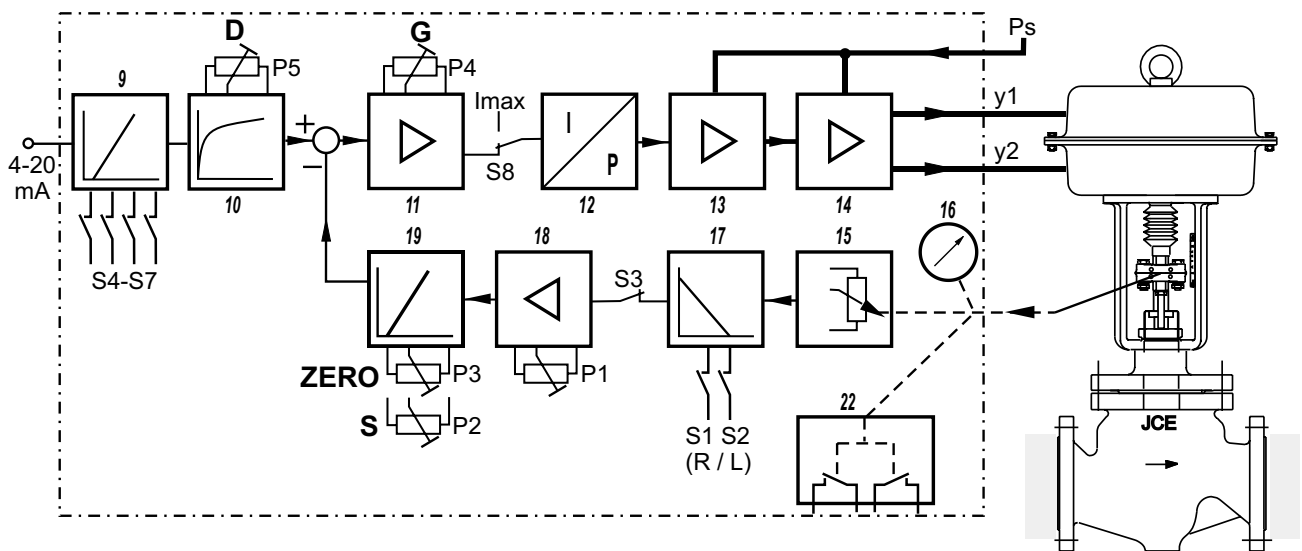

1.3 Operation

The supply of the electronics unit is diverted from the current signal 4 to 20 mA at the input.

The current value is measured and is suited in input circuit **9** to the desired input range (control action or split range) via switches S4 - S7. In circuit **10** the signal is provided with an adjustable time constant settable via potentiometer P5.

The resulting internal signal is guided to the analog control circuit **11**, the gain of which is adjustable via potentiometer P4. The output of the control circuit drives the electro-mechanic converter (IP module) **12**, which controls the analog single acting or double acting pneumatic amplifier **14** through the preamplifier **13**. The output of the amplifier **14** is the output pressure y (y_1, y_2) to the actuator. The pneumatic amplifiers are supplied with supply air P_s 1.4 to 6 bar (20 to 90 psig).

The position x of the actuator is measured by the position sensor (conductive plastic potentiometer) **15**. The desired direction of rotation is set in **17** via switches S1 and S2. The SPAN is suited to the stroke / rotation angle range via potentiometer P2, while ZERO is set in **19** via potentiometer P3. With switch S3 potentiometer P1 provides an internal zero adjustment in **18** carried out by the manufacturer (service function). The resulting feedback signal is guided to control circuit **11**.

The IP module receives its maximum drive current via switch S8 enabling checking of the function of the pneumatic unit.

The position x of the actuator is independently displayed at the mechanical travel indicator **16**.

The mechanical limit switch **22** (optional) enables independent alarm signals.

1.4 Safety requirements

Accident prevention

This device complies with regulations for the prevention of accidents **Power-Driven Work Aids** (VGB 5) of 1st October 1985.

In option "limit switch" do not touch control vane during operation - danger of injuries!

Electrical safety

This instrument satisfies the conditions for safety class III, overvoltage category I according to EN 61010-1 or IEC1010-1.

Any work on electrical parts must be done by qualified personnel if any supply is connected to the instrument.

The instrument must be used for its designated purpose and connected in accordance with its connection diagram (see pages 17 and 27).

Locally applicable installation regulations for electrical equipment must be observed, e.g. in the Federal Republic of Germany DIN VDE 0100 resp. DIN VDE 0800. The instrument contains no built-in fuses.

The instrument must be operated with safety extra low voltage SELV or SELV-E.

Safety precautions taken in the instrument may be rendered ineffectual if the instrument is not operated in accordance with the Master Instructions.

Limitation of power supplies for fire protection must be observed due to EN 61010-1, appendix F or IEC 1010-1.

Explosion protection

(Only if ordered)

Technical data for explosion protection see Product Specifications Sheet PSS EVE0107 A-(en).

For installations located in explosive atmospheres, all relevant national regulations and installation conditions must be observed, e.g. in the Federal Republic of Germany ExeV and DIN VDE 0165.

Attention:

When repairing explosion-protected equipment, observe the national regulations.

Repairs involving parts must be manufacturer's original parts.

The following applies to the Federal Republic of Germany: Repairs involving parts required for explosion protection must either be carried out by the manufacturer or by authorized personnel and confirmed by certificate.

EMC and CE

For notes regarding Electromagnetic compatibility EMC and CE labels see Product Specifications Sheet PSS EVE0107 A-(en).

In order to ensure EMC protection, the electronic board has to be screwed to the housing.

2 LABELS

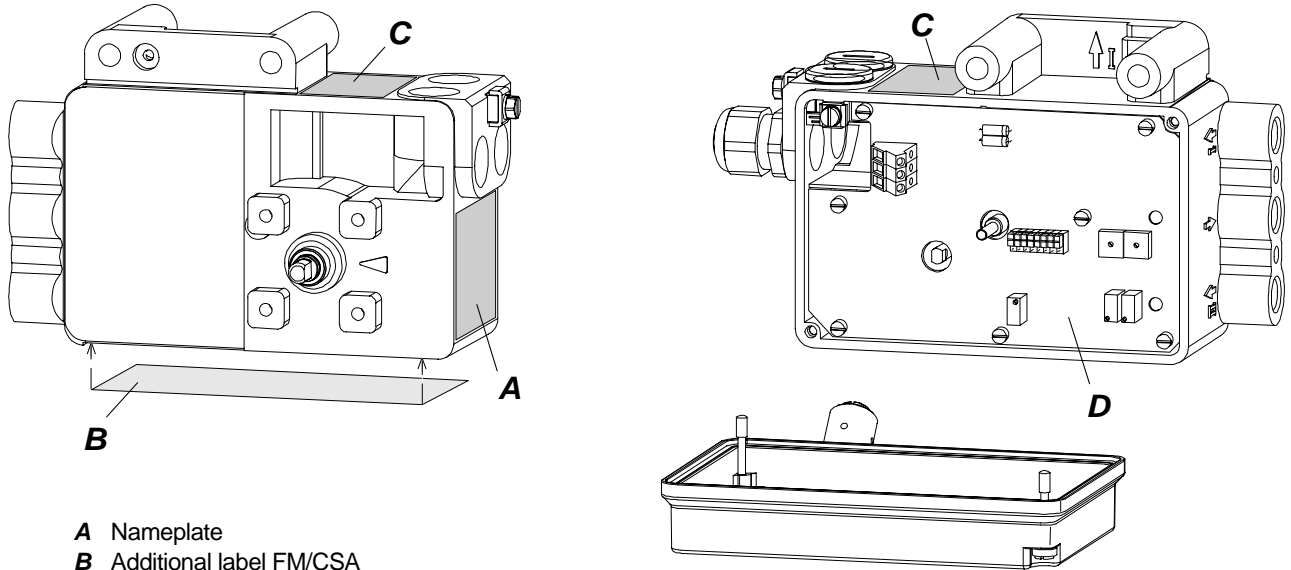

- A Nameplate
- B Additional label FM/CSA
- C Additional label for option "Limit switches"
- D Imprinted references regarding to settings

Nameplate A (Example)
Without Ex-protection

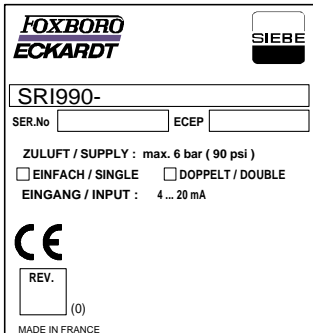

Nameplate A (Example)
Classified intr. safe by CENELEC
Type of protection "EEx ia"

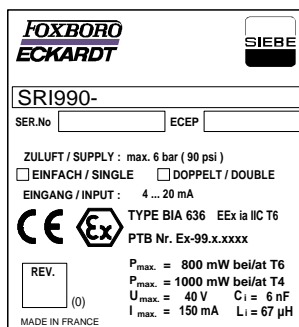

SRI990 [Device specification, Model Code]
SER.No [Serial number]
ECEP [Number for special engineered version]

Additional label B FM/CSA (Example)

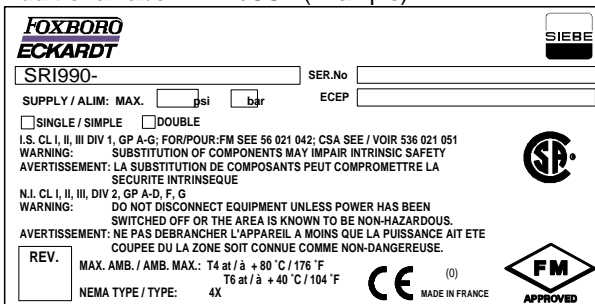

Additional label C at option "Limit switches" (Example)

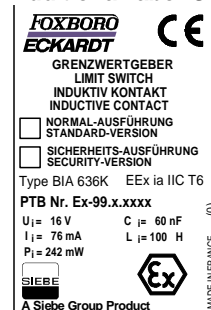

Measurement point label (Example)
Directly fixed or attached

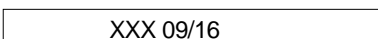

3 DESIGN

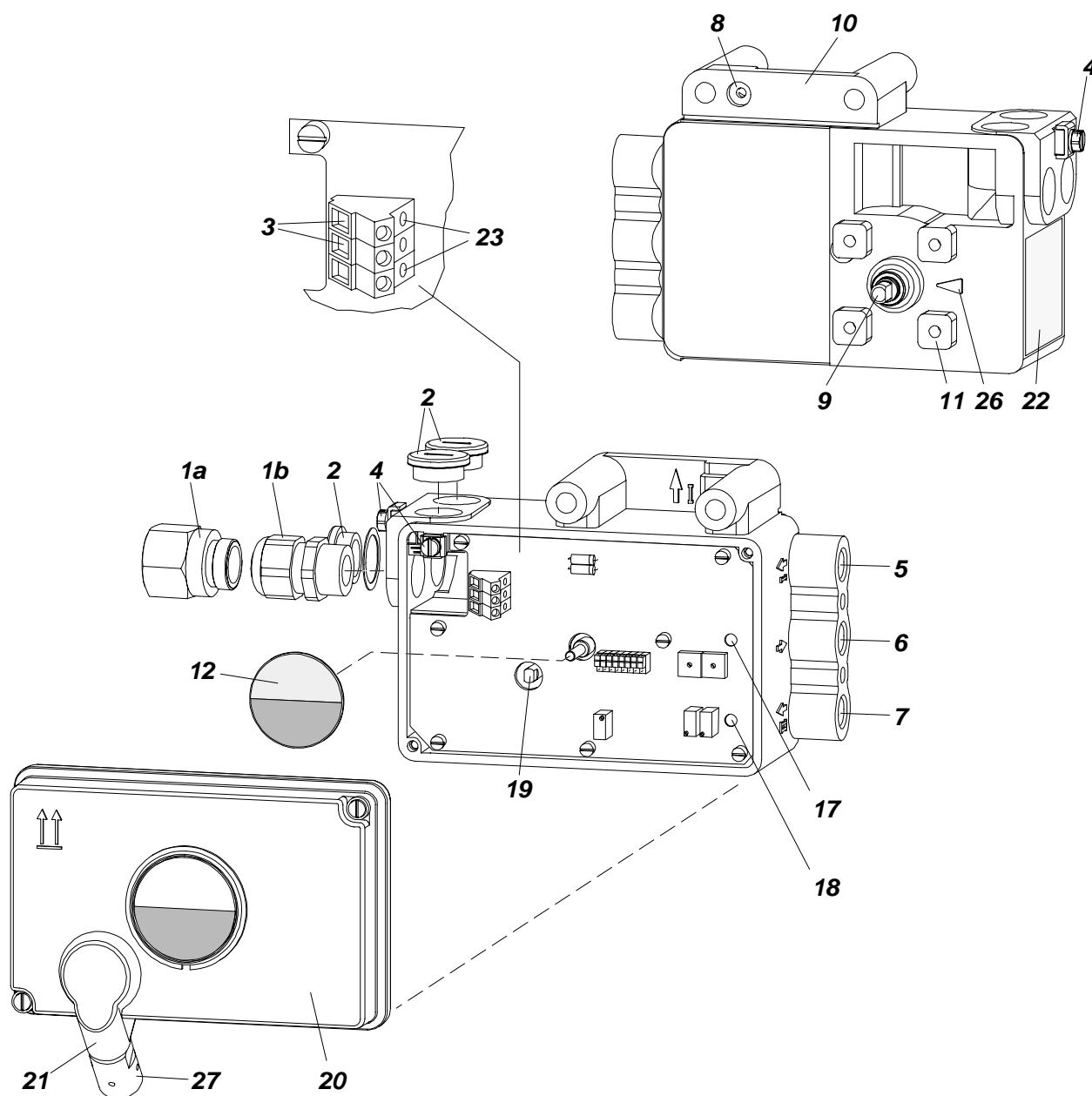

1a Adapter 1/2"-14NPT (see accessories)

1b Cable gland PG 13.5

2 Plug, interchangeable by Pos. 1

3 Screw terminals 11+ 12 for input (w)
I- to measure input current (see also item **23**)

4 Ground connection

5 Female thread 1/4-18 NPT for output I (y1)

6 Female thread 1/4-18 NPT for air supply (s)

7 Female thread 1/4-18 NPT for output II (y2)

8 Direct connection hole for output I (y1)

9 Feedback shaft

10 Connection manifold for mounting to linear actuators

11 Connection base for mounting to rotary actuators

12 Travel indicator

17 Air reducing throttle* for output I

18 Air reducing throttle* for output II

19 Shaft for limit switch connection

20 Cover with window to **12**

21 Air vent, dust and water protected

22 Nameplate

23 Connections for current measurement, 2 mm dia.
(integrated in side of terminals)

26 Arrow points to flat of feedback shaft at angle 0°

27 Ball valve for protection class NEMA 4X

3.1 Pneumatic Accessories

When mounting, check the proper seating of the O-rings and bolt on the accessories with the two M8 bolts. Unused outputs are closed by means of plastic plugs.

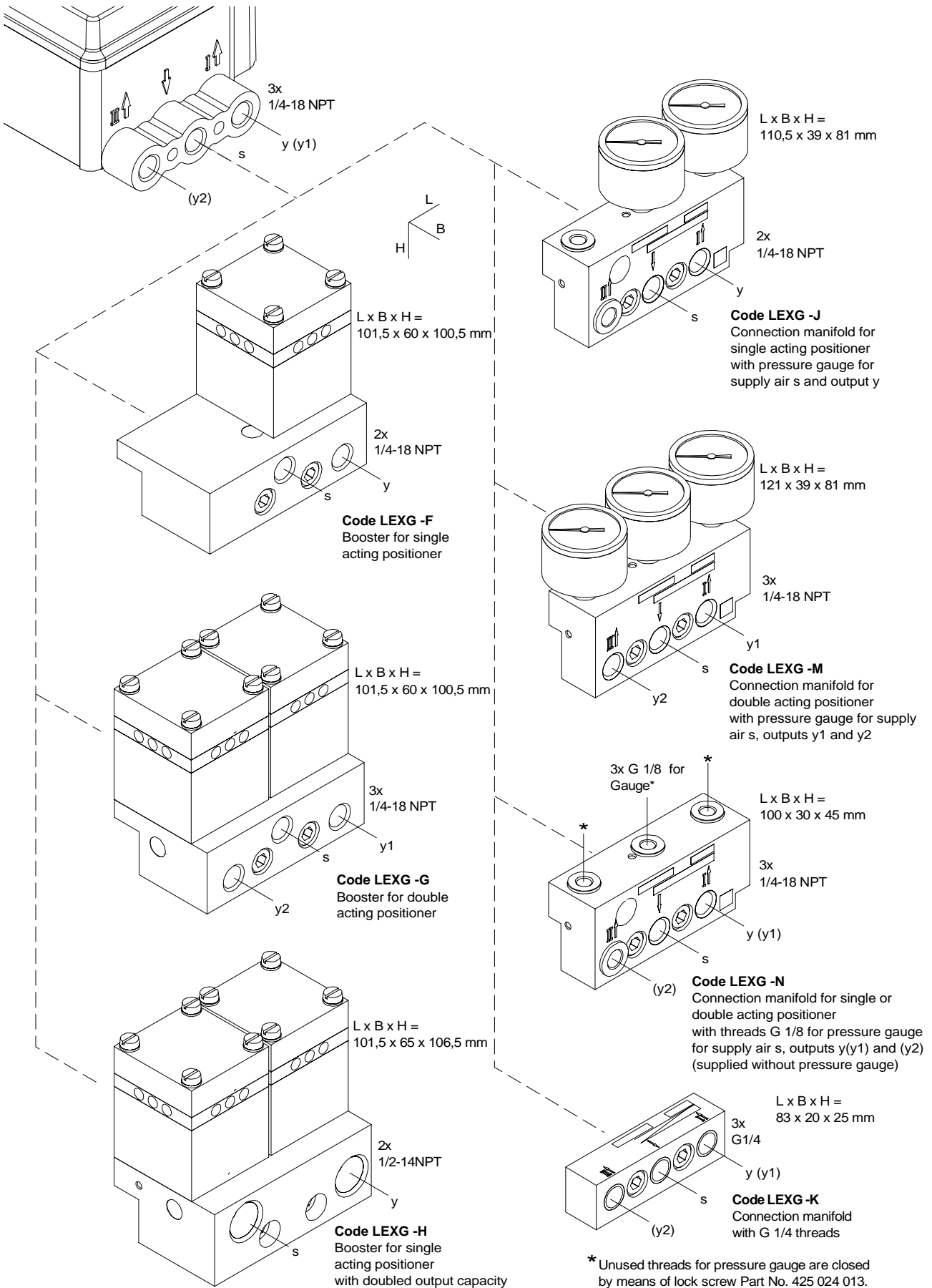

* Unused threads for pressure gauge are closed by means of lock screw Part No. 425 024 013.

4 MOUNTING TO LINEAR ACTUATORS

4.1 NAMUR Mounting - left hand -

Applicable to actuators with cast yoke or pillar yoke acc. to NAMUR (DIN IEC 534-6).

Mounting the positioner with pneumatic connections on the left side and electrical connections on the lower right side.

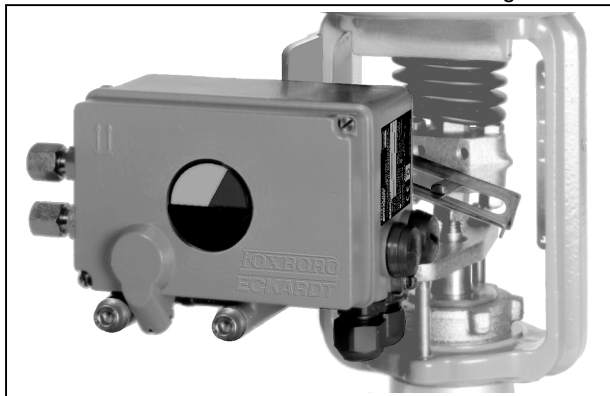

Attachment of the positioner to the actuator is made to the left using the mounting bracket and feedback lever for a NAMUR mount. Use:
attachment kit EBZG -H for a cast yoke, or
attachment kit EBZG -K for a pillar yoke.

- The side outputs I (or I and II, see page 6) are used. The rear output I is closed by means of a lock screw 522 588 013.

Pneumatic connections: Do not use Teflon tape for sealant. The fine fibres could disturb the function of the SRI990. Use only Loctite® #243 for sealant ¹⁾.

Screw-type glands for electrical connections are positioned on the lower or right side. Any unused threaded holes are closed by plugs.

When putting on the housing cover note that the air vent should face-down (see photo above).

4.1.1 Preparation of the positioner

Rotate the shaft stub of shaft **9** so that the flat on the shaft stub is perpendicular to the arrow **26** on the housing (detail see page 13). Fasten the feedback lever **A** to the shaft by means of spring washer and nut M8.

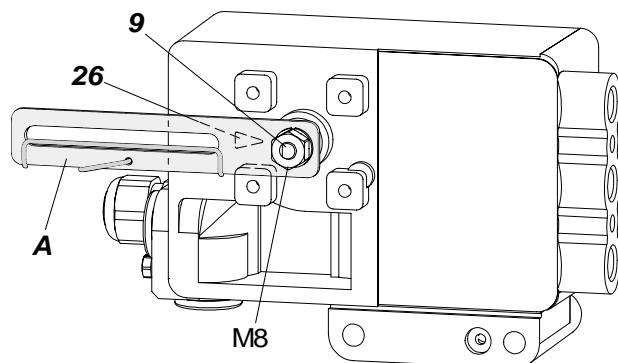

4.1.2 Preparation of the actuator

Screw the carrier bolt to the stem connector (see page 9) and lock it by means of a counter nut.

A carrier bolt with an adjustable length is used to be able to screw on various coupling pieces.

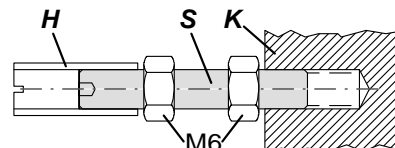

It consists of a stud **S**, which is screwed into the coupling piece **K** (with 3 mm Allen key) and locked with a lock nut M6. The threaded sleeve **H** is screwed onto it and locked with a lock nut M6. Make sure that the bolt is adjusted to the right length!

Fasten the mounting bracket to the left side of the yoke. For a cast yoke use a screw M8 x 30, for a pillar yoke use two U-bolts and two nuts.

4.1.3 Mounting of the positioner

Fasten the positioner to the mounting bracket using two spring washers and two screws M8 x 80.

Note, the carrier bolt **B** is in the slot of the feedback lever **A** and the compensating spring **F** touches the carrier bolt.

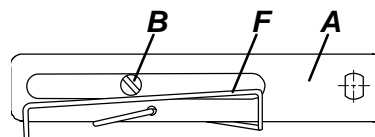

Fig.: Feedback lever

For optimum utilization of the positioner operating range, it is recommended that the arrangement is adjusted according to the following procedure before fixing. At an actuator position in the middle of travel range, the feedback lever position should be perpendicular to the actuator stem and the angle range should be between 10° ... +10° and 30° ... +30°.

Procedure:

Set the actuator to the middle of its travel range by supplying it with an independent pressure. Fasten the mounting bracket so that carrier bolt and the mark on mounting bracket are about the same distance from the valve body. Fasten the positioner to the mounting bracket so that a suitable angle range is selected.

It is recommended that the pneumatic and electrical connections are made after adjusting the position.

1) Apply only to male thread

4.1.4 NAMUR Mounting Dimensions – left hand –

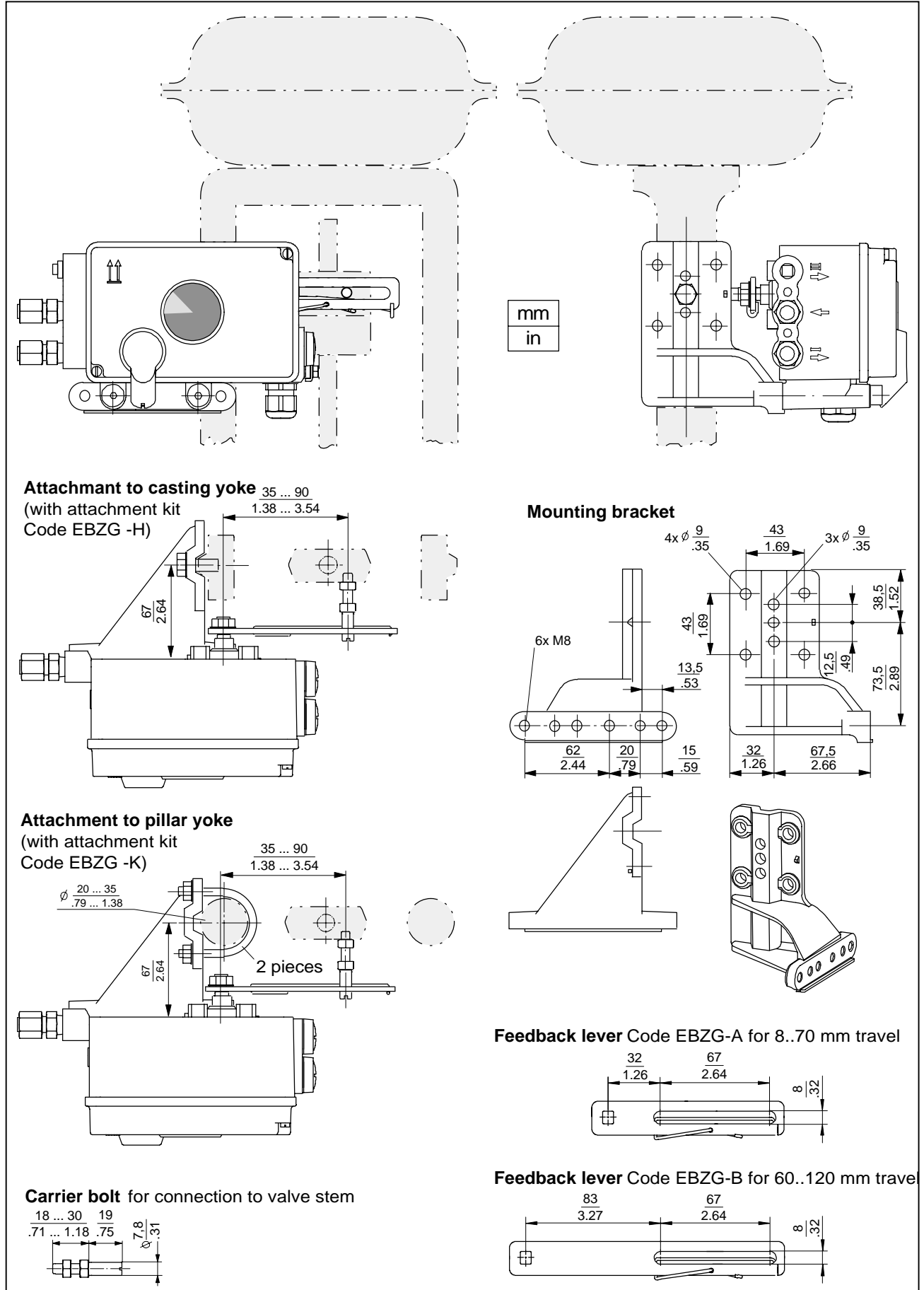

4.2 NAMUR Mounting - right hand -

Right-hand mounting is done if for instance left-hand mounting is not possible for structural reasons. Applicable to actuators with cast yoke or pillar yoke acc. to NAMUR (DIN IEC 534-6).

Mounting the positioner with pneumatic connections on the right side and electrical connections on the left side.

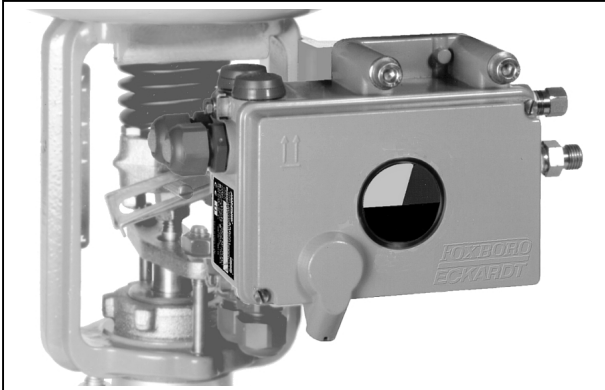

Attachment of the positioner to the actuator is made to the right using the mounting bracket and feedback lever for a NAMUR mount. Use:
attachment kit EBZG -H for a cast yoke, or
attachment kit EBZG -K for a pillar yoke.

- The side outputs I (or I and II, see page 6) are used. The rear output I is closed by means of a lock screw 522 588 013.

Pneumatic connections: Do not use Teflon tape for sealant. The fine fibres could disturb the function of the SRI990. Use only Loctite® #243 for sealant ¹⁾.

Screw-type glands for electrical connections are positioned on the left side. Any unused threaded holes are closed by plugs.

When putting on the housing cover note that the air vent should face-down (see photo above).

4.2.1 Preparation of the positioner

Rotate the shaft stub of shaft **9** so that the flat on the shaft stub is perpendicular to the arrow **26** on the housing (detail see page 13). Fasten the feedback lever **A** to the shaft by means of spring washer and nut M8.

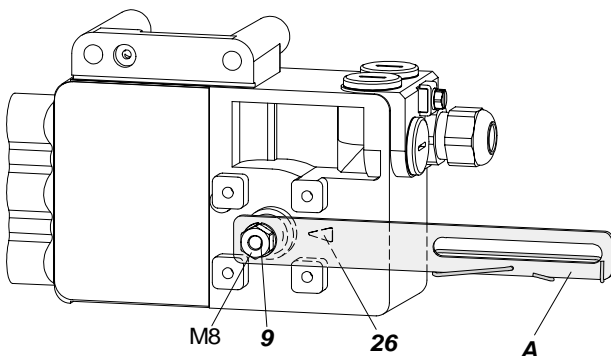

1) Apply only to male thread

4.2.2 Preparation of the actuator

Screw the carrier bolt to the stem connector (see page 9) and lock it by means of a counter nut. A carrier bolt with an adjustable length is used to be able to screw on various coupling pieces.

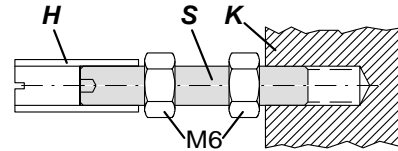

It consists of a stud **S**, which is screwed into the coupling piece **K** (with 3 mm Allen key) and locked with a lock nut M6. The threaded sleeve **H** is screwed onto it and locked with a lock nut M6. Make sure that the bolt is adjusted to the right length!

Fasten the mounting bracket to the left side of the yoke. For a cast yoke use a screw M8 x 30, for a pillar yoke use two U-bolts and two nuts.

4.1.3 Mounting of the positioner

Fasten the positioner to the mounting bracket using two spring washers and two screws M8 x 80.

Note, the carrier bolt **B** is in the slot of the feedback lever **A** and the compensating spring **F** touches the carrier bolt.

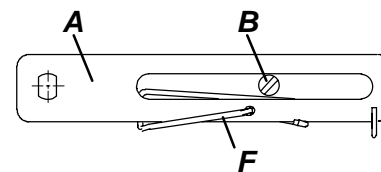

Fig.: Feedback lever

For optimum utilization of the positioner operating range, it is recommended that the arrangement is adjusted according to the following procedure before fixing. At an actuator position in the middle of travel range, the feedback lever position should be perpendicular to the actuator stem and the angle range should be between $10^\circ \dots +10^\circ$ and $30^\circ \dots +30^\circ$.

Procedure:

Set the actuator to the middle of its travel range by supplying it with an independent pressure. Fasten the mounting bracket so that carrier bolt and the mark on mounting bracket are about the same distance from the valve body. Fasten the positioner to the mounting bracket so that a suitable angle range is selected.

It is recommended that the pneumatic and electrical connections are made after adjusting the position.

4.2.4 NAMUR Mounting Dimensions – right hand –

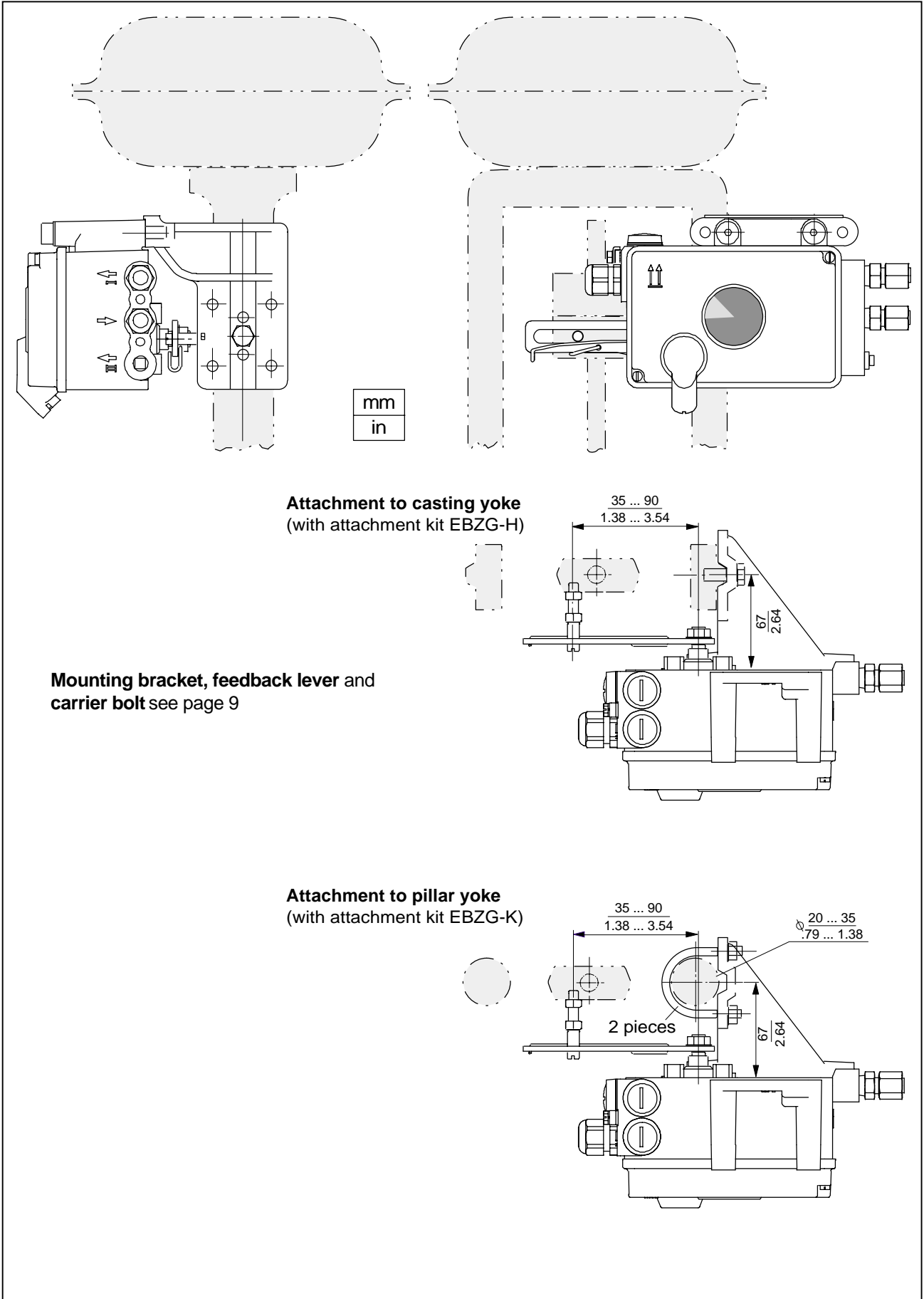

4.3 Direct Mounting

Actuators with appropriately prepared yoke (PA200, PA350) enable mounting of the SRD991 directly to the actuator yoke.



The attachment of the positioner is accomplished by bolting it directly to the actuator yoke using the feedback lever for a direct mount (with attachment kit EBZG -D).

The rear output I and the side outputs I and II are used as follows (see page 6) :

- Actuator single acting, spring force closes:
The rear output I is used (remove lock screw in hole **D**).
The side output I is closed by means of a lock screw 522 588 013.
- Actuator single acting, spring force opens:
The side output I is used.
The rear output I is closed by means of a lock screw.
- Actuator double acting:
The rear output I and the side output II is used.
The side output I is closed by means of a lock screw.

Pneumatic connections: Do not use Teflon tape for sealant. The fine fibres could disturb the function of the SRI990. Use only Loctite® #243 for sealant¹⁾.

Screw-type glands for electrical connections are positioned on the side. Any idle female threads are closed by means of plugs.

When putting on the housing cover note that the air vent should face-down (see photo above).

4.3.1 Preparation of the positioner

Rotate the shaft stub of shaft **9** so that the flat on the shaft stub is perpendicular to the arrow **26** on the housing (detail see page 13). Fasten the feedback lever **A** to the shaft by means of spring washer and nut M8.

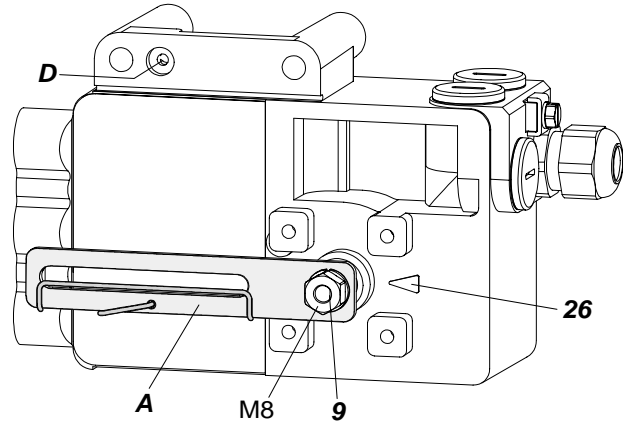

4.3.2 Preparation of the actuator

Screw in the carrier bolt **B** on the coupling piece **K** on the drive spindle **S** at the lower left and lock it by means of a nut M6.

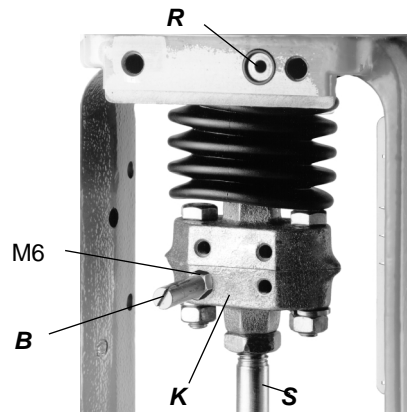

4.3.3 Mounting of the positioner

Fasten the positioner to the upper part of the yoke using 2 spring washers and 2 screws M8 x 80, as shown above. The rear output I of positioner has contact to the air duct **R** in the yoke.

Attention: Note the correct position of the O-ring on the yoke for the rear connection !!

Note, the carrier bolt **B** is in the slot of the feedback lever **A** and the compensating spring **F** touches the carrier bolt.

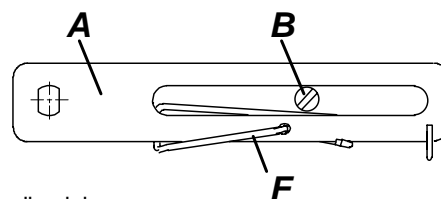
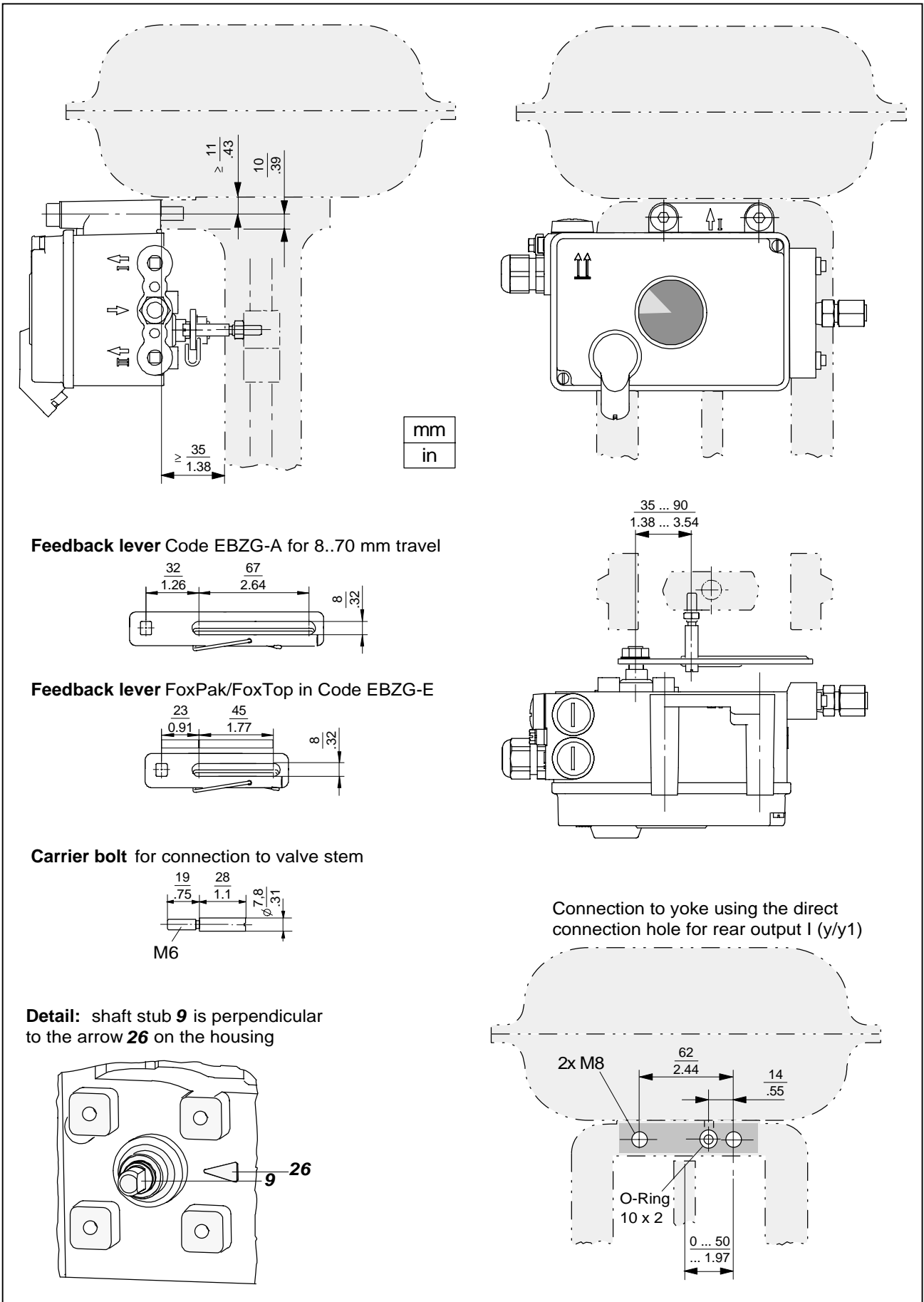

Fig.: Feedback lever

1) Apply only to male thread.

4.3.4 Mounting dimensions – direct mounting –



5 MOUNTING TO ROTARY ACTUATORS

5.1 Type of mount

Applicable to rotary actuators that meet the VDI/VDE 3845 standard for mounting. Installation position of positioner: Mount the positioner so that the pneumatic connections are in the same direction as the longitudinal drive axis of the actuator as shown in the photograph below.

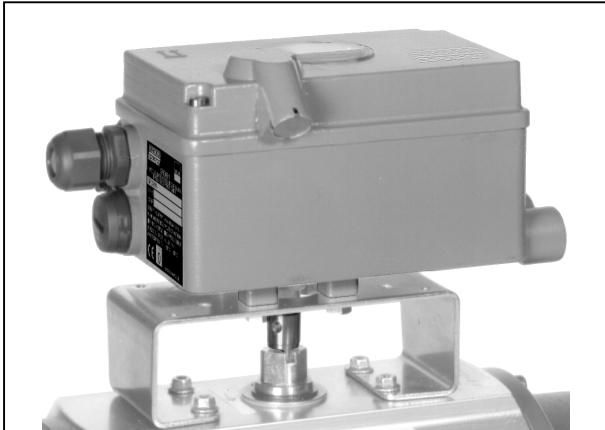

Attention: The feedback shaft **9** of the SRD has no mechanical stop, therefore may spin round. The permissible rotation angle range is between +50 and -50 degrees around the arrow at the housing concerning the flat area of the feedback shaft (also see detail page 13 bottom). Since a rotary actuator has a rotary angle of about 90 degrees the mounting as described in the following must be carried out very precise.

Attachment of the positioner to the actuator is made by using the rotary adaptor kit EBZG -R.

- Either the side outputs I (or I and II) are used and the rear output I is closed by means of the lock screw 522 588 013.

Pneumatic connections: Do not use Teflon tape for sealant. The fine fibres could disturb the function of the SRD. Use only Loctite® #243 for sealant ¹⁾.

Screw-type glands for electrical connections are used as needed. Any unused threaded holes are closed by plugs.

Caution! Prevent accumulation of water in the instrument in this mounting position by sealing cable entry against water. Provide a continuous supply of dry instrument air.

5.1.1 Preparation of positioner

Valve must be in failsafe position²⁾ and the direction of rotation of the actuator drive shaft must be known. These items are extremely important for proper functioning. These items can be checked as follows in case they are not clear:

In the single-acting actuator the force of the installed springs closes. The pressure-less actuator is in failsafe position. Through manually feeding compressed air it can be seen whether the actuator drive shaft rotates to the left or to the right. In the powerless SRD is y1 pressureless.

In the double-acting actuator without spring reset both air chambers are basically equal. Failsafe position can be either "open" or "close". Therefore, indication of the fail- safe position has to be determined by engineering. Then the direction of rotation may be determined by manual feeding of compressed air. In the powerless SRD is y1 pressureless and y2 under pressure.

Bolt **2** is screwed into actuator drive shaft **1** for subsequent centering of the rotary adaptor **3**. The attachment console is mounted to the stroke actuator (see photo).

Attachment diagram for bracket

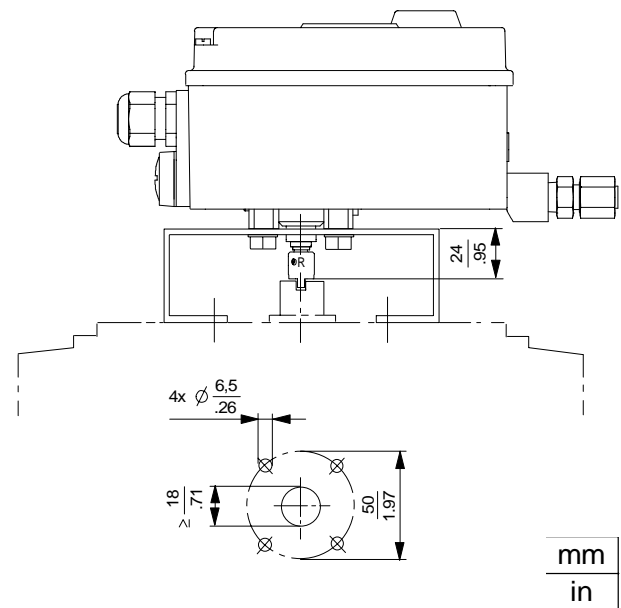

Rotary adaptor

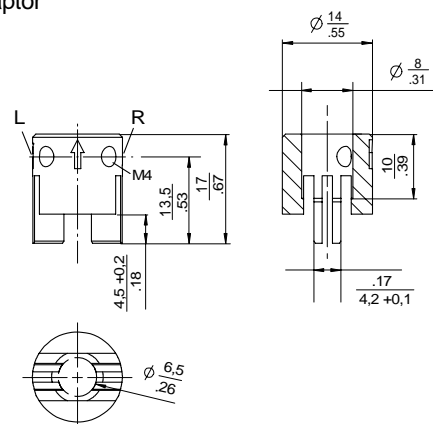

1) Apply only to male thread.
2) Failsafe position: Defined position in case of failure of input signal

5.1.2 Preparation of the actuator

First the rotary adaptor is being prepared:

For attachment to a counter-clockwise or **left** turning actuator secure the stud screw **4** in the threaded hole “**L**” of the rotary adaptor; hole “**R**” remains open. See Fig. 27.

For attachment to a clockwise or **right** turning actuator secure the stud screw **4** in the threaded hole “**R**” of the rotary adaptor; hole “**L**” remains open. See Fig. 28.

Now place the rotary adaptor **3** with two washers **5** on the feedback shaft **9** of the positioner against the stop.

Note :

When the product temperature rises, the drive shaft **1** becomes longer. Therefore, the rotary adaptor **3** must be mounted so that approx. 1 mm (0.04 in.) of clearance results between the drive shaft **1** and the rotary adaptor **3**. This is achieved by placing an appropriate number of washers **5** on the feedback shaft stub **9** before attaching the rotary adaptor. Two washers should result in a clearance of 1 mm.

Now screw and tighten the bolt in the coupling against the flat part of the feedback shaft (do not screw against thread!).

Finally turn the feedback shaft in such a way that the arrow of the coupling points to the arrow of the SRI housing. Beginning and end positions of the actuator drive shaft **1** and feedback shaft **9** are marked in figure 27 (left-rotating actuator) and in figure 28 (right-rotating actuator) by arrows for the respective direction of rotation.

The feedback shaft is now in the normal position corresponding to the failsafe position of the actuator. No shifting of feedback shaft anymore!

5.1.3 Mounting of positioner

SRI and actuator are in failsafe position.

Attach the SRI on the console in such a way that the catch of coupling **3** is guided into the groove of shaft **1**. Use bolt **2** to center and align the positioner to the actuator. Be careful not to shift shafts **1** and **9** and that both shafts are exactly flush.

Fasten the positioner to the bracket by means of 4 lock washers and 4 screws M6 x 12

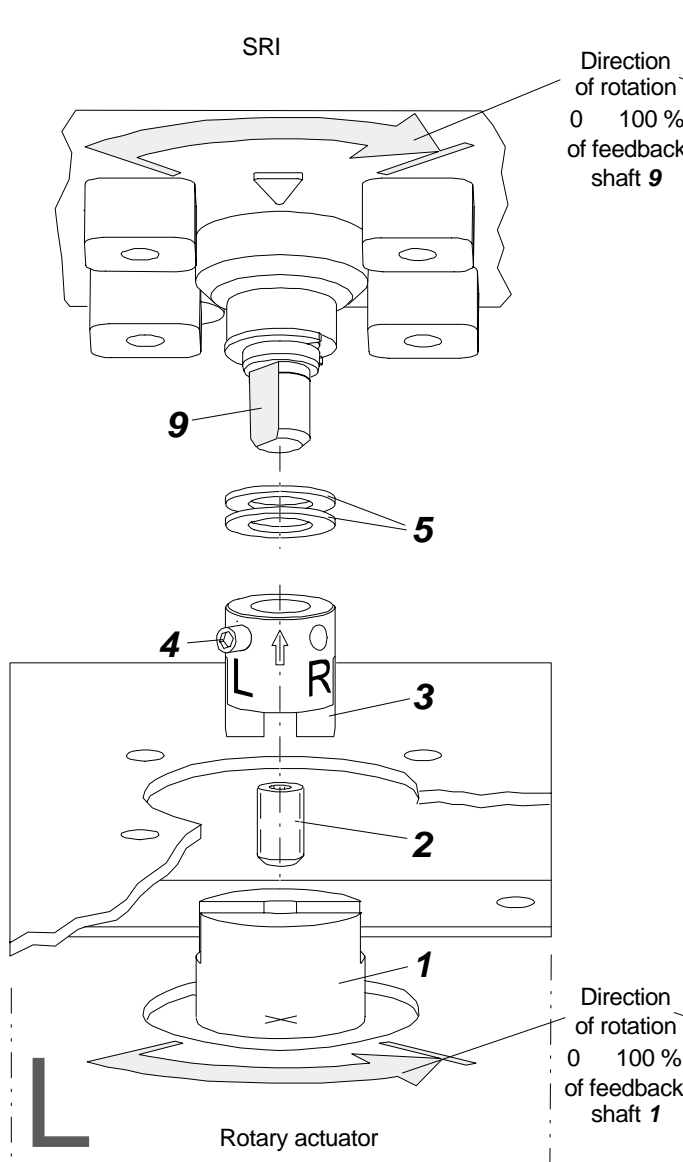

Figure 27: Mounting if actuator is rotating to the left

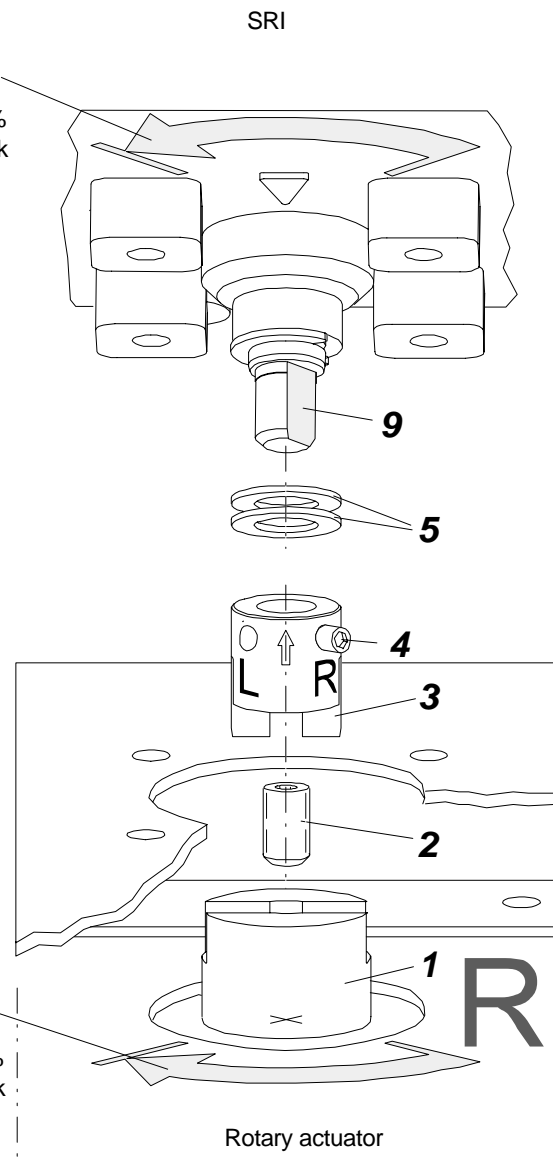
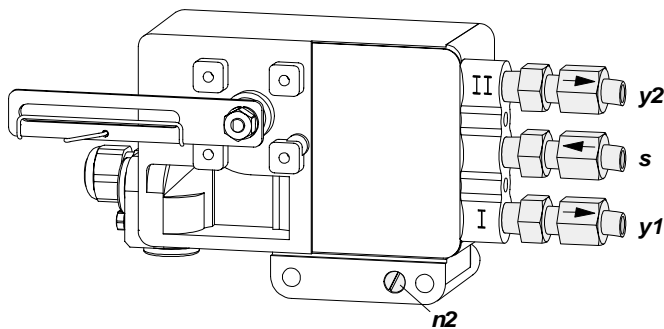
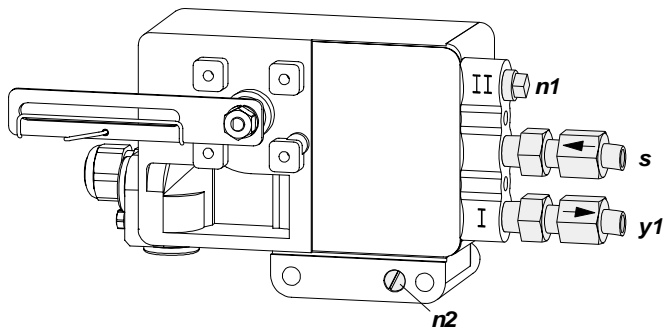
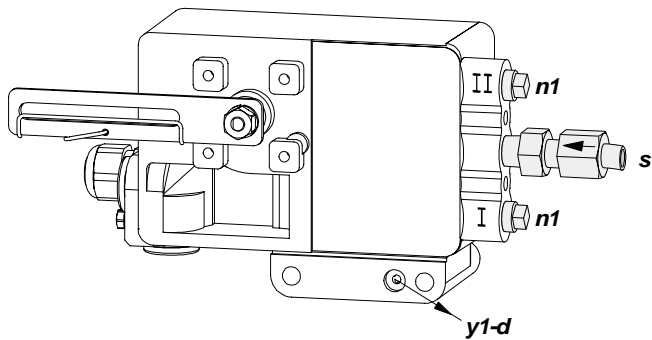

Figure 28: Mounting if actuator is rotating to the right

6 PNEUMATIC CONNECTIONS



Following alignment and mounting of the positioner to the valve, pneumatic tubing has to be provided.

The connection illustrations depend on the respective version.

Explanation of abbreviations:

s Supply air

y1-d Output 1 for direct mounting, depressurized at currentless electronics. When using this output **y1** has to be closed by means of hex. screw.

y1 Output 1, depressurized at currentless electronics. When using this output, **y1-d** has to be closed by means of sealing screw and O-ring.

y2 Output 2 for double-acting actuator. Full pressure at currentless electronics. Closed at single-acting actuator.

n1 Hex. screw with NPT thread

n2 Sealing screw with O-ring

7 ELECTRICAL CONNECTION

The safety requirements on page 4 must be observed!

Unused cable glands should be closed off.

Guide cable through gland **1**. The gland is suitable for cable diameters of 6 to 12 mm (0.24 to 0.47 in). Observe the tightness of the cable entry.

Provide electrical connection of input line at screw terminals **3** marked 11+ and 12-. The terminals are suitable for wire cross-sections of 0.3 to 2.5 mm² (22 -14 AWG).

Note: When connecting shielded cable connect the cable shield **only** to the system! Do not connect the cable shield to the SRI !

Connection to terminals (pos. **3+**, **3-**):

- 11+ Input w+
- 12- Input w-

The input current can be measured at tip jacks 23+ and 23- (integrated in terminals, underneath the screws). The tip jacks fit plugs with a diameter of 2 mm (0.08 in)

In order to improve EMV protection by integration into local grounding the internal and external grounding conduct connection 4 is available.

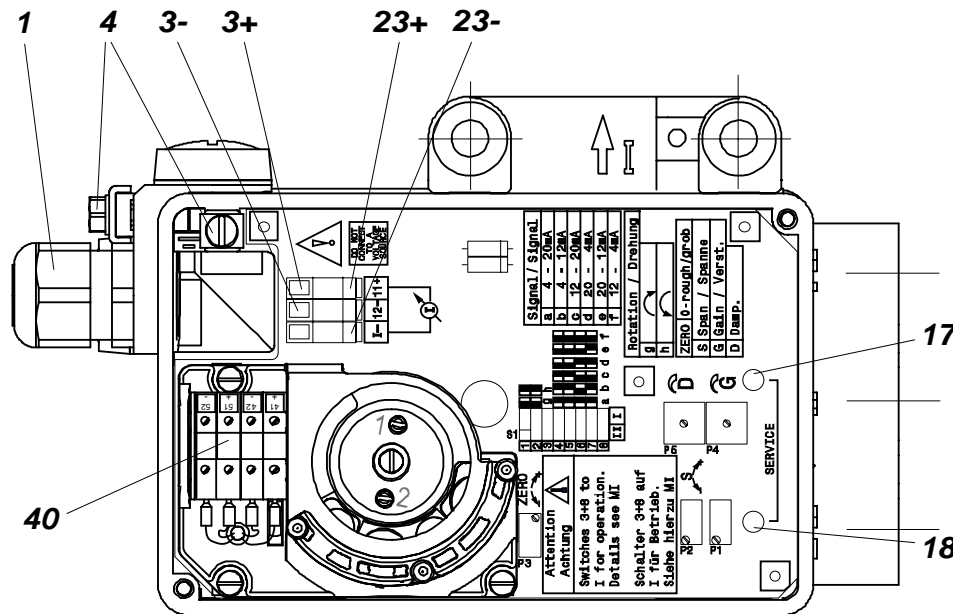

Optional equipment 'limit switch' (see terminals **40**)

| SRI990-xxxT, U via inductive sensor | |
|-------------------------------------|--------|
| Mark | Signal |
| 41 + | GW1 |
| 42 - | GW1 |
| 51 + | GW2 |
| 52 - | GW2 |

GW Binary output ext. supplied

8 START-UP

8.1 General

First of all, the nameplate should be checked, especially with respect to references to Ex / non- Ex, input signal, single / double acting.

Before starting the positioner the SRI has to be mounted to the actuator; an input signal 4 to 20 mA or split range have to be available. The supply air connection must have sufficient capacity and pressure of 1.4 to 6 bar (20 to 90 psig) and should not exceed the maximum operating pressure of the actuator.

The SRI990 can be adjusted by means of switches and potentiometers when the housing cover is opened.

Attention: Configuration using switches and potentiometers may interfere with operation of the actual process! During configuration it is recommended that there is no flow through the valve.

At initial start-up various adjustments have to be set. The following procedure is recommended:

- Setting of direction of rotation of feedback lever (chapter 8.2)
- Setting of input signal range
e.g. 4 to 20 mA or split range (chapter 8.3)
- Setting of gain (chapter 8.4)
- Setting of zero and span (chapter 8.5)
- Setting of damping (time constant, chapter 8.6)
- The position indicator **12** is attached to the desired position after selection of the transmission at indicator shaft (chapter 8.7)
- The air capacity throttles at the pneumatic output (screws **17** and **18** underneath of the SERVICE openings) are factory-set to the operating value and are normally not reset (exception see chapter 8.8).
- When attaching the housing cover make sure that the venting opening points to the bottom.

Settings via switches and potentiometers

For the setting of the SRI990 and the adjustment of various parameters 8 dip switches and 5 potentiometers are available. See electronics imprint as follows:

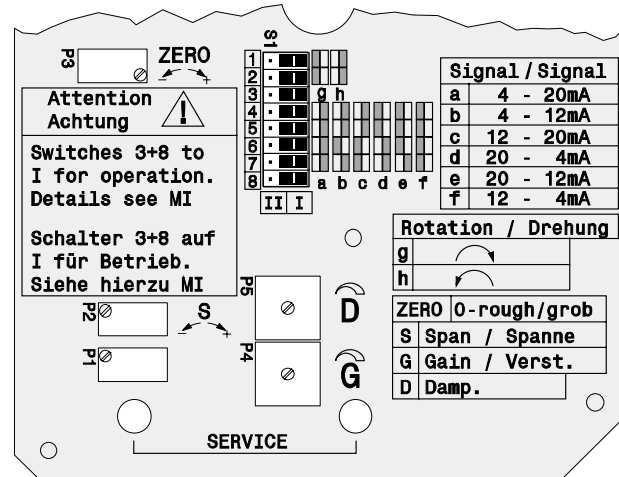

The potentiometers are for the setting of:

- Zero point (ZERO): P3
- Span (S): P2
- Gain (G): P4
- Damping (D): P5
- Electronics alignment: P1¹⁾

Single-threaded potentiometers with limited rotation angle to set gain (G) and damping (D) are available, where the actual position is indicated by an arrow. To set zero point (ZERO), span (S) and the electronics alignment¹⁾ multiple-threaded potentiometers (approx. 30 rotations) without rotation limitation are used.

The switches are for the setting of:

- Direction of rotation of feedback lever (switches 1, 2)
- Electronics adjustment (switch 3)¹⁾
- Signal range (switches 4, 5, 6 and 7)
- Pneumatic test (switch 8)

The switch numbers (1 through 8) are imprinted on the electronics. The possible switch position ("I" and "II") are imprinted below switch 8. The switch positions are defined as follows:

Switch Position "I":

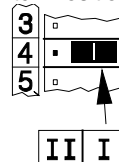

Switch Position "II":

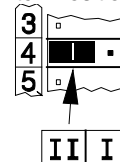

Caution!

Switches 3 and 8 must be during operation in position "I". Prior to resetting switches 1 to 8 it is recommended to shut-off the respective part of the installation since processes are activated influencing and disturbing the current process. Therefore, it is recommended that no medium flows through the valve during configuration.

1) Adjustment of electronic board (in workshop, see page 23)

8.2 Setting of direction of rotation of feedback shaft

If the actuator moves from starting to end position, the direction of rotation of the feedback shaft is to the right or left hand, depending on the mounting method of the positioner selected and on the configuration of the actuator (spring closes/ opens/ double-acting).

For proper functioning this direction of rotation must be set at positioner (via switches 1+2).

The direction of rotation is defined as direction of rotation of the feedback shaft from the starting to the end position looking at the positioner from the front. See following illustration (shown is: left hand mounting, spring closes, direction of rotation L).

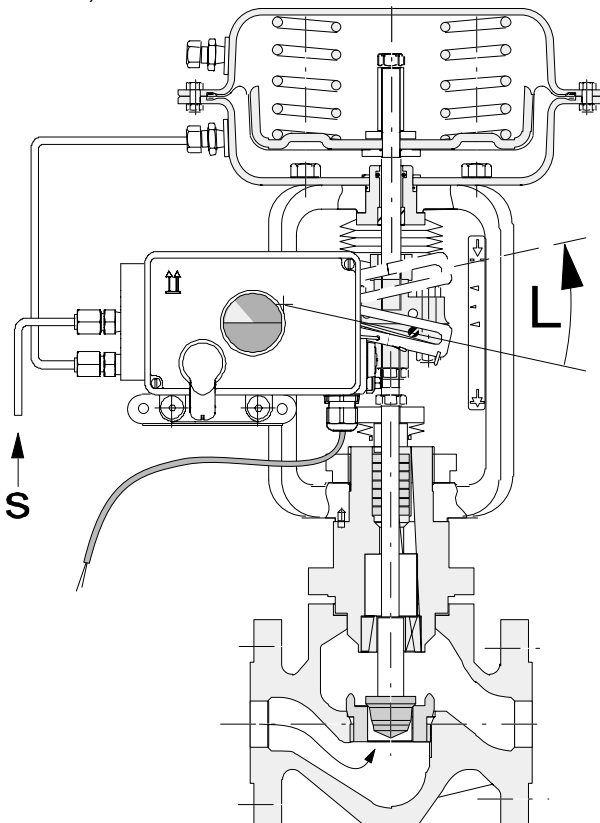

Direction of rotation of feedback shaft of a single-acting **stroke actuator** with spring:

| | | |
|--|--------------------|---------------------|
| Left hand mounting, direct mounting | Spring in actuator | Right hand mounting |
| L | Spring closes | R |
| R | Spring opens | L |

Direction of rotation of feedback shaft for a **rotary actuator**:

| | |
|--|---|
| Actuator opens rotating to the left | Actuator opens rotating to the right |
| L | R |

Direction of rotation of feedback shaft of the double-acting actuator is a. o. determined by the mounting side and the tubing of the pneumatic outputs to the actuator. It has to be considered that in a powerless SRI990 the output y1 will become pressureless and y2 contains air supply pressure.

The direction of rotation of the feedback shaft is set via switches 1+2; see the following illustration.

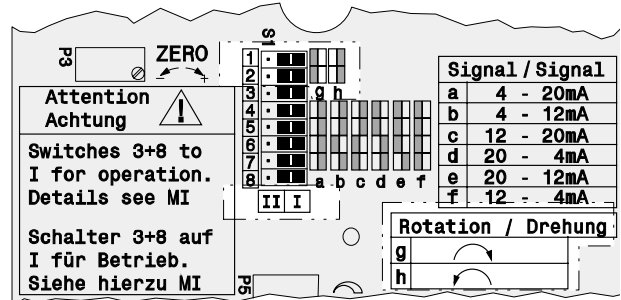

L: left-hand rotating feedback shaft switch 1+2 on "I"
 R: right-hand rotating feedback shaft: switch 1+2 on "II"

Remarks: If the direction of rotation is not in the right manner, the actuator moves to the end position with full force, and the positioner cannot be controlled.

Definitions

Stroke, stroke range of the membrane actuator is defined for rotary actuator as **angle, angle range**.

0 % position is the mechanical impact at actually closed valve (caution if using handwheel and mechanically adjustable stroke limitation!)

100 % position is the mechanical impact at actually open valve.

8.3 Setting of Input Signal Range

The following input signal ranges can be set for the SRI990 via switches 4 to 7:

| 0 % | 100 % | item | S4 | S5 | S6 | S7 |
|-------|-------|------|----|----|----|----|
| 4 mA | 20 mA | a | I | I | I | I |
| 4 mA | 12 mA | b | I | I | II | I |
| 12 mA | 20 mA | c | I | I | II | II |
| 20 mA | 4 mA | d | II | II | I | I |
| 20 mA | 12 mA | e | II | II | II | I |
| 12 mA | 4 mA | f | II | II | II | II |

The switch positions for the setting of various signal ranges are imprinted on the electronics. See illustration.

For 4 to 20mA the switches 4 to 7 are set to position "I" (as shown).

This concludes the setting of the input signal range!

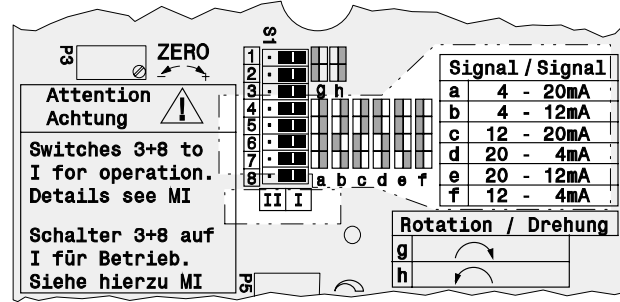

Split Range

If several positioners are operated at one current loop in sequence with the standard signal 4 to 20 mA, individual valve positions may be allocated to each device, which also may overlap if necessary.

This function is useful if an additional control range is demanded which cannot be covered by one valve only. A valve of smaller nominal size can be applied overtaking the smallest quantities; a parallel mounted valve of bigger nominal size takes on the larger quantities.

Example: Setting the signal range to 12 to 20 mA
It is recommended to shut off current of the positioner prior to resetting of the input signal range (turn-off input signal). The switches 4 and 5 are set to position "I" and switches 6 and 7 to position "II".

The individual switch positions are shown in the following illustration.

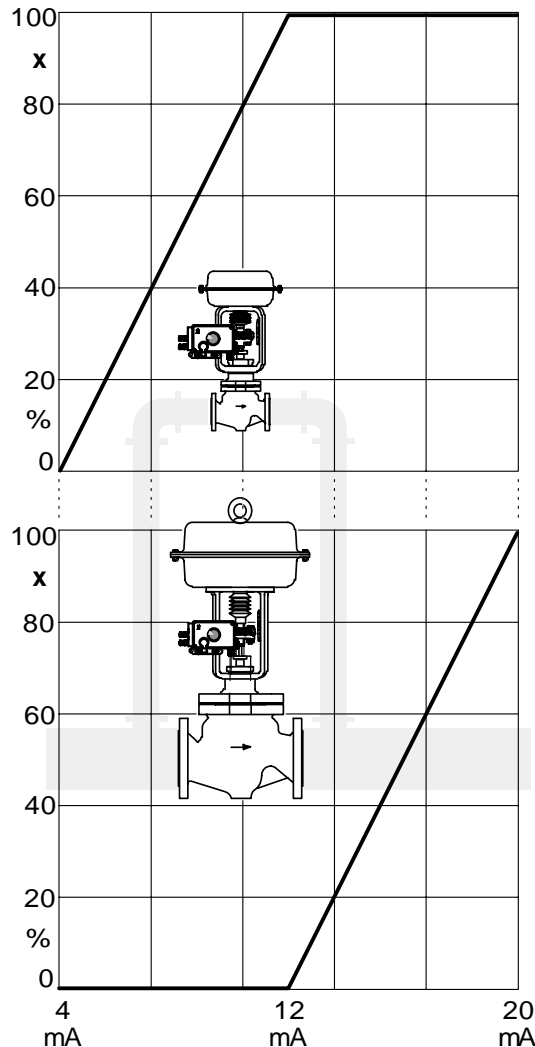
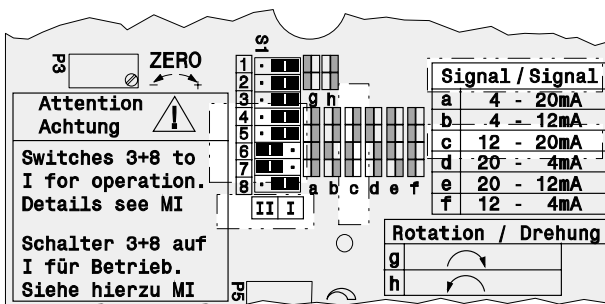

Split range, subdivision of input signal range
Example: At low current, only the smaller valve positions; from approx. 50 % the large valve is added

8.4 Setting of gain (G)

The loop amplification of the positioner is set via potentiometer P4 for gain (G). The maximum possible gain is thereby determined by the stability behavior of the control loop. It is selected in such a way that the actuator no longer oscillates at constant given input value.

Rotation to the right P4: amplification is increased
Rotation to the left P4: amplification is reduced

If the positioner control loop oscillates, gain (G) must be reduced. It has to be considered that a change of gain changes the control deviation, therefore, requiring setting of the potentiometer for the position range (zero and span).

8.5 Setting of zero (ZERO) and span (S)

Following settings in chapters 8.2 through 6.4 at initial start-up setting of zero point (ZERO) and span (S) are performed as follows:

- Enter starting value of command variable (beginning of stroke).
- Turn potentiometer P3 for zero point (ZERO) until actuator just begins to move from its end position.

Rotation to the right P3: zero point is increased
Rotation to the left P3: zero point is reduced

- Enter final value of variable (end of stroke)
- Turn potentiometer P2 for span (S) until actuator exactly reaches its end position.

Rotation to the right P2: span is increased
Rotation to the left P2: span is reduced

These settings influence amplification, therefore adjusting in chapter 8.4 may become necessary.

8.6 Setting of damping (D)

Potentiometer P5 for damping (D) influences the dynamic behavior of the actuator at a discontinuous change of the input signal. The input signal is provided with an additional time constant for this purpose. The time constant is only noticeable in the position control loop if the time constant set via potentiometer is larger than the position time of the actuator.

Rotation to the right P5: damping is increased
Rotation to the left P5: damping is reduced

The effect of the positioning time may be checked by entering input signal jumps. The range limits and the gain are not influenced by a change.

8.7 Setting of the travel indicator

The mechanical travel indicator is coupled to the feedback shaft of the positioner by a gear. The gear has two selectable ratios 1 : 2 and 1 : 6.¹⁾

Selection of gear ratio:

For rotation angles of the feedback shaft less than 30° select a ratio 1 : 6. This gear selection amplifies the feedback shaft rotation angle six times and for example, a 20° angle is shown as 120°.

For rotation angles greater than 30° select a ratio of 1 : 2. This gear selection amplifies the shaft rotation angle by a factor of two and for example, a 45° angle is shown as 90°.

For rotary actuators the rotation angle is equal to the rotation angle of the actuator. Consequently, a 90° rotation angle will result in a 180° display angle for the 1 : 2 gear ratio.

For linear actuators the rotation angle is determined by travel span and feedback lever length. In this case, an exact 180° display angle can only be achieved for a 30° rotation angle using a 1 : 6 gear ratio. If any other rotation angle results, either the closed or full open position can be set to be indicated at, for example 0° or 180°. However, if the closed position is chosen for display, then the full open display position angle is dependent on travel span, feedback lever length and gear ratio. If the full open position is chosen for display, then the closed position angle becomes dependent.

Setting gear ratio:

Remove travel indicator **12**. Pull out pin **12b** for a ratio 1 : 2 or push in the pin for a ratio 1 : 6. Use a smooth turning operation to free the gears and to set pin **12b** against the stop. See illustration.

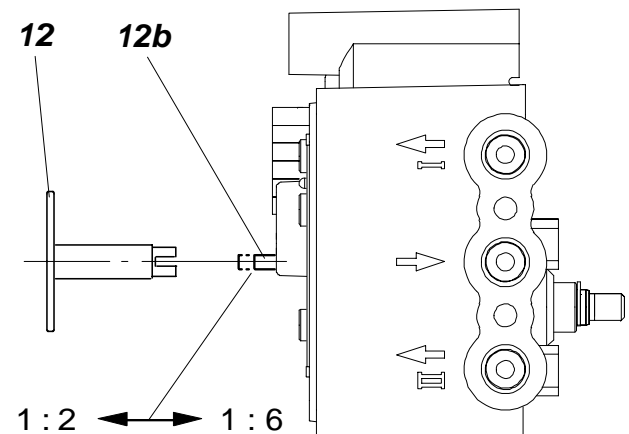

Turn the travel indicator **12** to the desired position, put it on the gear shaft against the stop and pinch the wire ring for secure coupling.

1) The values are rounded for making easier calculations. The exact ratios are 1 : 1.83 and 1 : 6.28 .

8.8 Air reducing throttles

Attention: Service only

Air flow to the actuator may be reduced via air reducing throttles **17** and **18**.

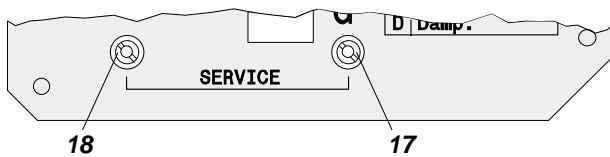

Ex-factory the air capacity is non-throttled; generally, this is the most favorable setting. In the non-throttled condition the screw head is even with the amplifier surface. Since the flatness of the screw heads is not visible in the installed electronics, the basic setting can be restored as follows:

- turn off air supply
- carefully turn air reducing throttle screw clockwise until impact, thereafter 5 complete return rotations (counter-clockwise)
- restart air supply

Reducing of output air capacity (Service only)

Output air capacity may be reduced in exceptional cases only in small volume actuators with a small spring range if after optimization of the control still oscillating tendency exists (amplification of control loop is too high). For this purpose turn air reducing throttle screws **17** and **18** to a maximum of 5 rotations clockwise.

Caution: Amplifier may be damaged if a loud noise can be heard from amplifier resulting from too strong reducing. Immediately turn back throttles significantly!

8.9 Basic adjustment of electronics

Attention: Service only

The electronics unit has been sufficiently factory-adjusted; an adjustment at delivery is not required. The potentiometer is secured by means of lacquer against unintentional operating.

In the event an adjustment of the electronics becomes necessary (e.g. following exchange of electronics) the procedure is as follows:

- Enter input current 4 mA.
- Switch S3 to "II": positioner control loop is opened.
- Turn potentiometer P1 until actuator just begins to move from its end position.
- Return S3 to "I".

8.10 Pneumatic test

Attention: Service only

To check the pneumatic parts of the positioner by directly applying current to the IP module (no control).

Procedure: Put switch 8 in position "II" (see illustration).

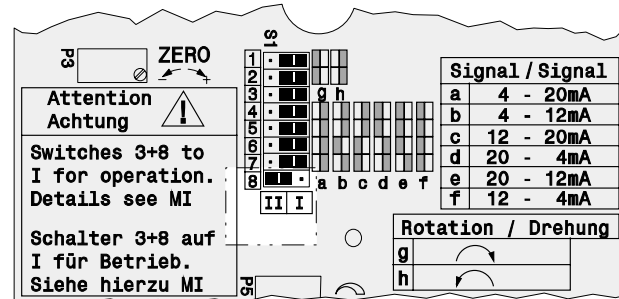

Attention!

Resetting of switch 8 initiates actions influencing and possibly disturbing the current process! Therefore, no medium should flow through the valve during these settings.

Setting switch 8 to position "II" actuates a pneumatic test checking the function of the positioners pneumatic system including its control. If switch 8 is set from position "I" (condition of operation) to position "II", the pressure in the actuator goes to nearly air supply pressure. The actuator moves to the direction associated with maximum pressure.

If no reaction is shown, check:

- does air supply exist?
- is plug connected to IP module?

If these items are okay, possibly the electronics or a pneumatic part are defect. Exchange see page 24.

During operation switch 8 must be in position "I" at all times!

9 DECOMMISSIONING

Before decommissioning the unit, disconnect supply air and the electrical input signal.

10 DIAGNOSIS

| Fault | Possible cause | Solution |
|--|--|---|
| Actuator does not react to existing input signal or to changes of input signal | Pneum. connections were interchanged | Check pneum. connections, see page 16 |
| | Electric connections were interchanged | Check electric connections, see page 17 |
| | Wrong setting of zero and span | Check, see page 21 |
| | IP module or pneumatic part defective | Carry out Pneumatic Test, possibly change part, see page 25 |
| | Direction of rotation interchanged | Change direction of rotation |
| Output pressure does not reach full capacity | Supply air capacity insufficient | Check air supply |
| | IP module defect | Carry out Pneumatic Test, possibly change module, see page 25 |
| | Filter in air supply connection plugged | Exchange filter, see page 24 |
| Actuator moves to end position | Positioner mounted on wrong side or switch 1+2 set faulty (R/L) | Check mounting side as per table page 19 |
| | Pneumatic test still active (switch 8 = "II") | Return switch 8 to "I", see page 22 |
| | Pneumatic connections were interchanged (double-acting version) | Check connections, see page 16 |
| Unstable behaviour, position control circuit oscillates | Gain too high | Reduce gain, see page 21 |
| | Friction on valve packing too great | Loosen packing gland slightly or replace |
| | Piston actuator: Friction at cylinder too great | Reduce gain, see page 21 |
| Stroke range cannot be set | Positioner does not fully decompose pressure | Check air supply (max. 6 bar) |
| | | Check gain, see page 21 |
| | | Carry out pneumatic test (switch 8 = "II"), see page 22 |
| Pneumatic test is without effect | No air supply | Connect air supply |
| | No input signal | Connect input signal |
| | IP module is not connected, or IP module or a pneumatic part defective | Connect IP module, or exchange part (workshop) |

11 MAINTENANCE

11.1 General

The positioner SRI990 requires little maintenance. When replacing components during repair work, the safety requirements on page 4 must be observed!

11.2 Supply filter replacement

An obstructed supply filter can be replaced. Unscrew the air supply fitting, remove the filter and exchange the filter with a new one.

11.3 Removal of electronics unit

Pull off travel indicator **12**. To remove the electronics unit **40**, loosen the 7 screws at front, see illustration below.

Lift off electronics unit vertically to top. Disconnect plugs **41** and **42** (see page 25) from the board. Do not use tools to remove plugs because components could be damaged. Tight-fitting plugs can be easily removed by tilting them diagonally inward before pulling them off.

Connect plugs **41** and **42** to the new electronics unit **40** and attach the new unit by using the 7 screws at front (attention with the cables).

11.3.1 Conversion of positioner

Positioners of the POSYS series consist of identical mechanical and pneumatic components and accessories. A conversion to either a "digital" or "intelligent" positioner is possible by simply exchanging the electronics unit.

Procedure:

- a) exchange electronics unit, see chapter 11.3
- b) mark change on nameplate
- c) start-up - see associated master instructions:

| Device Model Code | Communication | Setpoint | Documentation |
|-------------------|---------------|----------|---------------|
| SRD991-xH | HART | 4-20 mA | MI EVE0105 A |
| SRD991-xE | FOXC0M | 4-20 mA | |
| SRD991-xF | FOXC0M | digital | |
| SRD992 | - | 4-20 mA | MI EVE0106 A |

Reference to explosion-proof devices:

Conversion of the electronics unit has to be considered as change to explosion-proof device, and therefore, only permitted in accordance with country specific regulations. Valid in the Federal Republic of Germany: Conversion to be certified as change according to § 9 ElexV by an authorized expert.

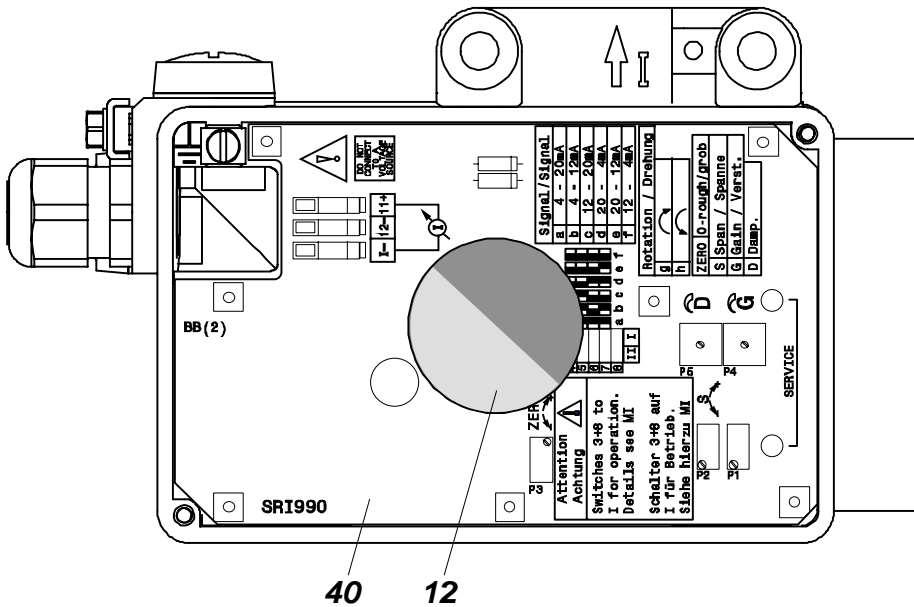

11.4 Replacement of mechanical and pneumatic units

First remove the electronics unit **40** (see preceding page).

11.4.1 Amplifier replacement

Release the pneumatic amplifier **43** from the base plate and replace O-rings between the amplifier and base plate¹⁾. Use 3 O-rings for a single-acting amplifier and 5 O-rings for a double-acting amplifier. If replacing a single-acting amplifier with a double acting, remove sealing screw **44** before installation.

The air capacity throttle screws have to be released until the screw head is even with the amplifier surface (= no throttling).

11.4.2 Preamplifier replacement

Unscrew the preamplifier **45** from the base plate by removing screws **46** and **47**.

Replace 4 O-rings between preamplifier **45** and base plate¹⁾ and install new preamplifier.

11.4.3 Replacement of IP module

Remove the IP module **48** from base plate and replace with new IP module. Replace the O-ring between IP module and base plate and install new IP module.

11.4.4 Replacement of Feedback unit

First remove feedback lever or rotary adapter from feedback shaft. Now remove retaining ring from feedback shaft **9** (see page 6). Remove screws and pull out complete unit **49** consisting of feedback shaft, gears and position sensor.

Insert new feedback unit **49** and secure with screws.

Remember to replace the retaining ring at feedback shaft.

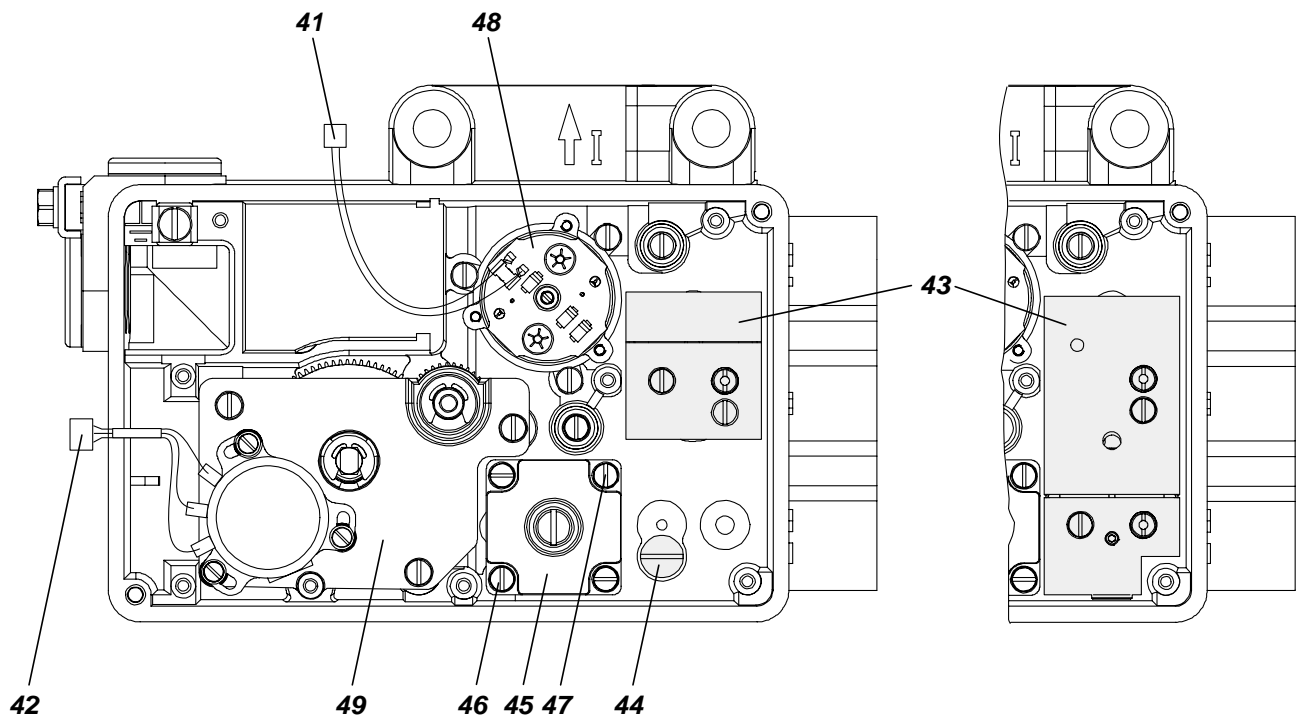

1) The base plate consists of a manifold and air ducts. O-rings are required to guarantee sealing of the mounted elements.

12 OPTION “Limit switch”

Rebuild to this option resp. exchange

Remove three screws **1** including tooth lock washer from plastic cover.

Attach limit indicator **2** so that the flattened shaft end **19** contacts the groove of the limit indicator shaft in the positioner.

Attach limit indicator by means of three screws **3** and washers. The feedback shaft at back of positioner should easily be turnable, thereby also moving the vanes of the limit indicator. If this is not the case, loosen screws **3** and flush-align the shafts of positioner and limit switch (turn coupling shaft several times).

Replace short travel indicator **12** by long travel indicator.

Screw high cover **20** (or standard cover with insert frame) on housing.

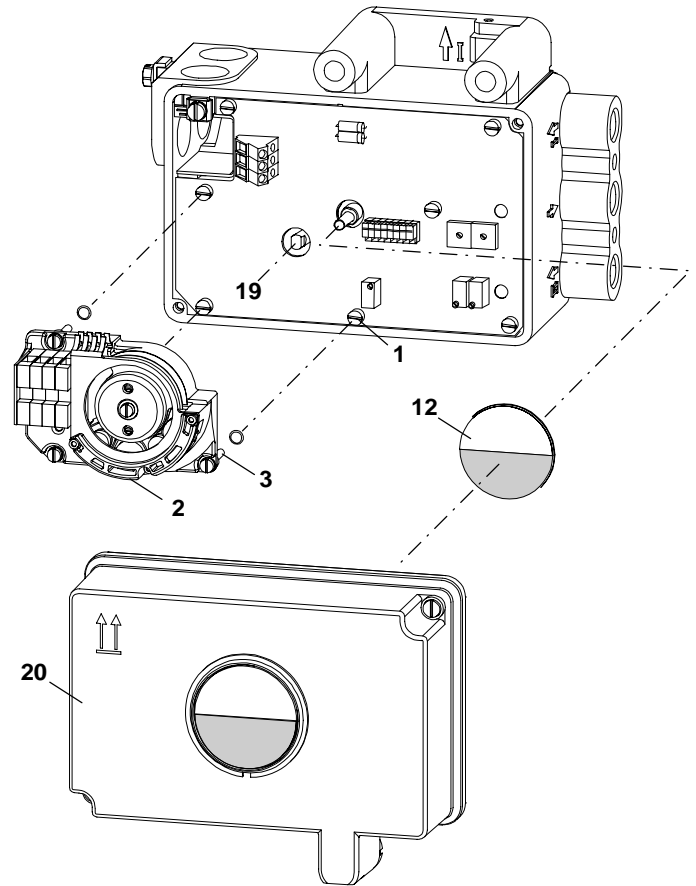

Switch functions

Feedback lever, feedback shaft and the control vanes are all connected to each other, without an intermediate transmission. The control vanes are therefore moving simultaneously with the same angle rate as the feedback lever. The length of the control vane corresponds with the swing angle of 120°.

Both control vanes are located on different planes. Each control vane can be seen independently from the other, because each has its own sensor.

By adjusting the screws (after loosening the center screw **10**), the control vanes can be adjusted relatively to the angle rate, so that e.g. one vane dives into and another dives out of the sensor (see illustration).

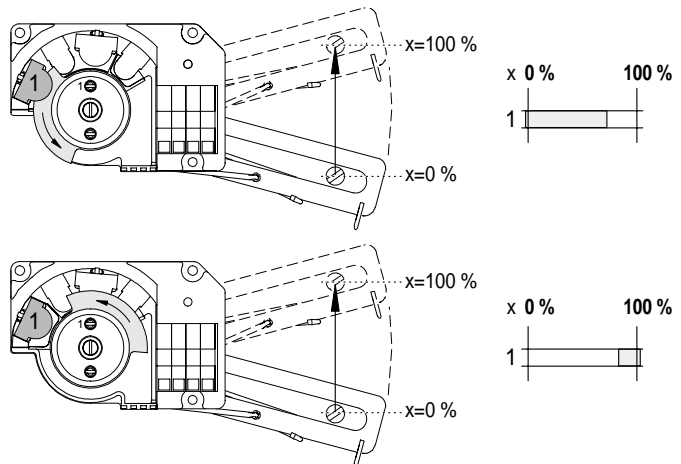

Setting limit switch trigger points

Loosen center screw **10** (1-2 turns; do not remove!), otherwise the control vanes will be damaged during the following steps.

Set trigger point switch GW1:

Turn screw at number 1 until desired switch behavior is reached.

Set trigger point switch GW2:

Turn screw at number 2 until desired switch behavior is reached.

To fix switch points retighten center screw **10**.

Do not touch control vanes during operation, danger of injuries!

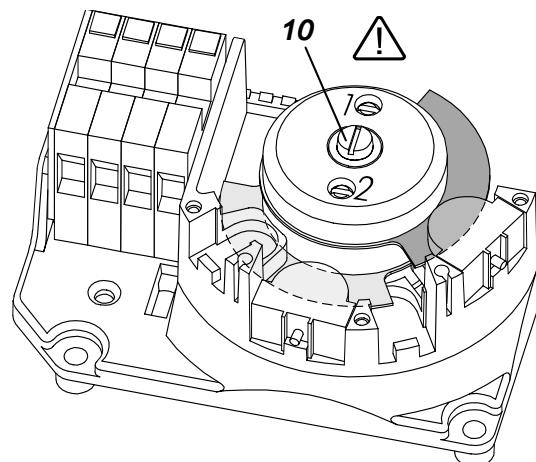

Levels of control vanes (illustration without cover)

13 SYSTEM CONFIGURATION

The safety requirements in page 4 must be observed!

13.1 Non-intrinsically safe operation

The SRI990 can be connected directly to the 4 to 20 mA output of the process control system or controller. Load RL approx. 300 Ohm.

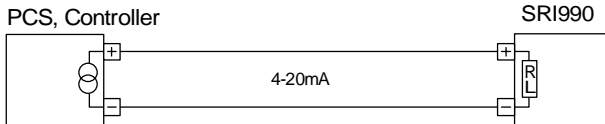

13.2 Intrinsically-safe operation

The SRI990 can be connected directly to an intrinsically safe 4 to 20 mA output of the process control system or controller. If no intrinsically safe output is available, a suitable buffer amplifier or safety barrier with an intrinsically safe output must be connected. During intrinsically safe operation the connection must be checked for conformance to intrinsic safety before commissioning.

Controller / process control system-output intrinsically safe:

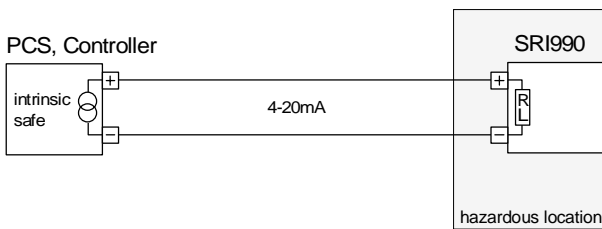

Controller / process control system-output not intrinsically safe:

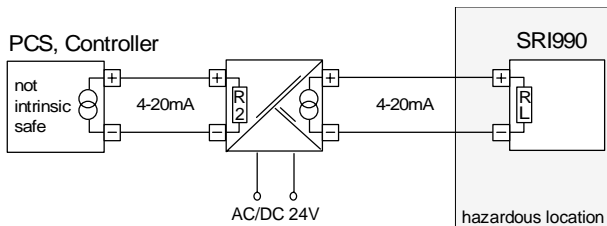

The following devices may be used:

| Device | Input Load R2 | Drives load at output | drives n *) SRI990 |
|--------|---------------|-----------------------|--------------------|
| TV928 | 50 | 600 | 1 pc. |
| TV228 | < 100 | 700 | 2 pcs. |
| II949 | RL+200 | 580 | 1 pc. |

*) For split range

All components connected to the SRI990 in a hazardous location must be Ex-approved. The limits are not to be exceeded in any case. These limits are also valid for connection of other capacitances, inductances, voltages and currents. Additional options may have different limit values than the basic device. See Product Specification Sheet PSS EVE0107 A-(en) and/or Certificate of Conformity.

13.3 Split range

If several actuators are to be controlled from an identical conduct variable and carry out full stroke only in a certain portion of this conduct variable, an individual SRI990 is to be provided for each actuator the zero and span of which can be set to the respectively desired partial range of the conduct variable.

The positioners are electrically switched in series. It is important that the permissible load of the process control system or controller is not exceeded (RL of an SRI990 approx. 300 Ohm).

The output voltage (idle voltage) must be >8.5 V per connected positioner. The total line capacitance is not to exceed 1 F.

Example: 2-fold split range

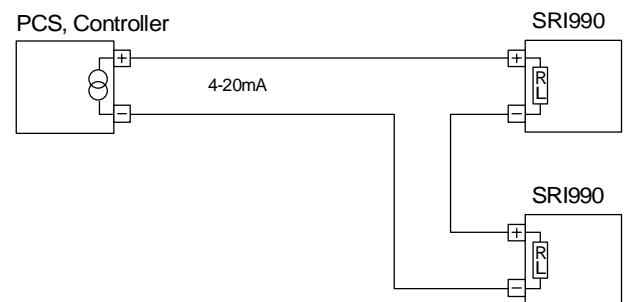

During intrinsically-safe operation identical conditions as described in chapter 13.2 are valid.

Setting of the positioners is described in page 20.

DIMENSIONS

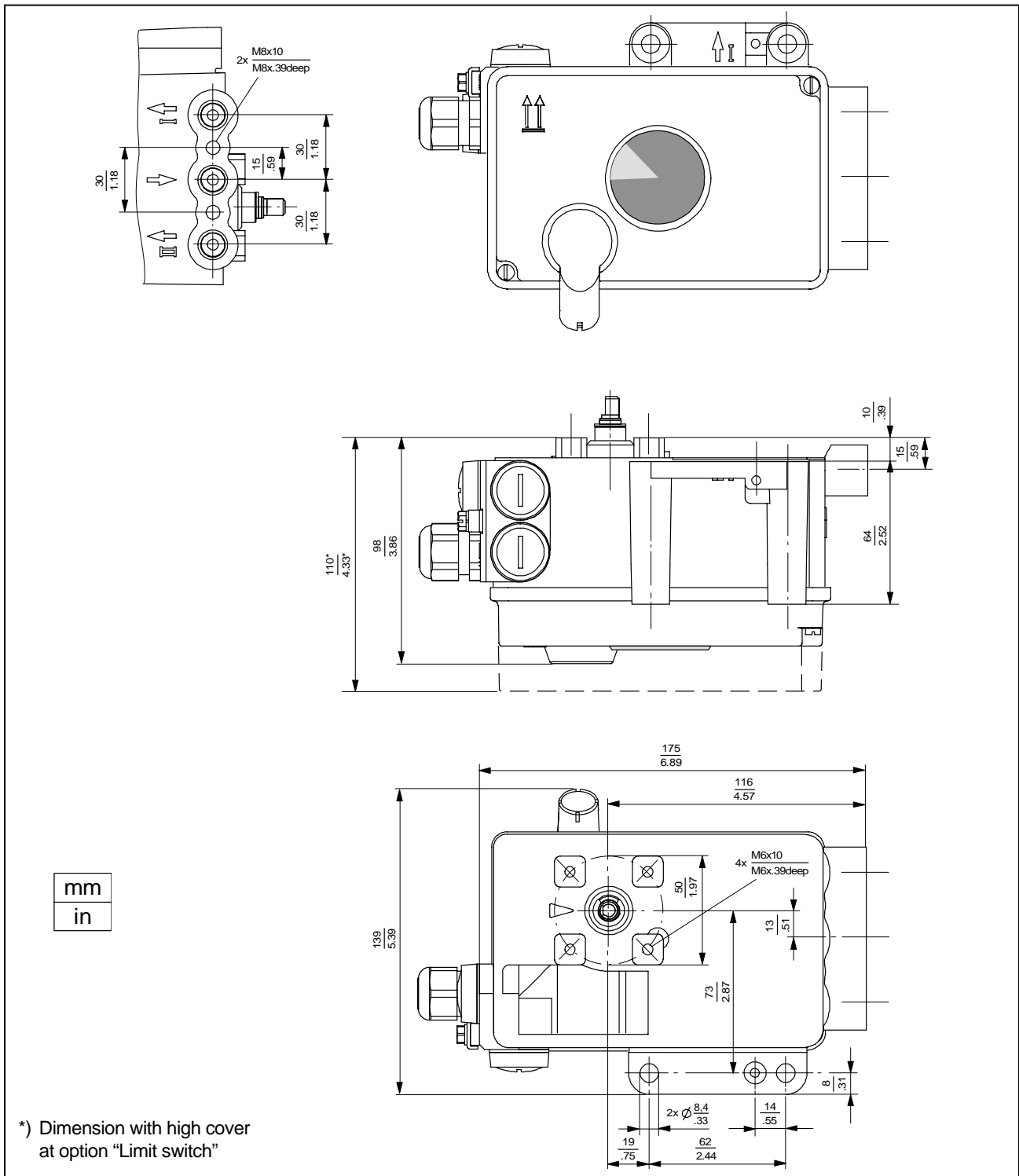

Subject to alterations - reprinting, copying and translation prohibited. Products and publications are normally quoted here without reference to existing patents, registered utility models or trademarks. The lack of any such reference does not justify the assumption that a product or symbol is free.

FOXBORO ECKARDT GmbH
 Postfach 50 03 47
 D-70333 Stuttgart
 Tel. # 49(0)711 502-0
 Fax # 49(0)711 502-597

DOKT 536 022 046