

## bourdon tube "solid-front" pressure gauges for high pressures, turret case DS 4.5" (125 mm)



These instruments are built in conformity with the construction and safety specifications of **ASME B40.1**.

In case of leaks or break of the elastic element the operator is protected by a stainless steel safety cell solid front and by the blow-out back. They are mainly used on high pressure water jet technology like water cutting machines, hydro blasting pumps and turbines, hydrodemolition. The TIG welding between the safety cell and the process socket strengthens the instrument and assures a better tight in case of dampening fluid. The advantages of filling the case of the instrument with a dampening fluid are: reduced pointer fluctuation, reduced wear of rotating parts of the movement when pulsant vibrations and pulsations occur. Moreover condensation and corrosive atmospheres which could damage the internal parts.

### 1.32.2 - Fillable Model

**Ranges:** 0...2500, 0...3000 and 0...4000 bar;  
0...30000, 0...40000 and 0...60000 psi/bar.

**Accuracy:** Grade 1A as per ASME B40.1 ( $\pm 1,0\%$  of F.S.V.).

**Ambient temperature:**  $-13...+149\text{ }^{\circ}\text{F}$  ( $-25...+65\text{ }^{\circ}\text{C}$ ).

**Process fluid temperature:**  $-22...+302\text{ }^{\circ}\text{F}$  ( $-30...+150\text{ }^{\circ}\text{C}$ ).

**Working pressure:**

75% of FSV for static pressure;

66% of FSV for pulsating pressure.

**Over pressure limit:** 10% of FSV (temporary).

**Protection degree:** IP 67 as per IEC 529.

**Socket material:** AISI 316L st.st.

**Bourdon tube:** duplex st.st. seamless tube.

**Case and blow out disk:** strengthened polyammides with fiber glass ,  
UV rays stabilized.

**Ring:** strengthened polypropylene, fiber glass.

**Safety cell:** stainless steel.

**Window:** safety glass.

**Movement:** stainless steel with internal limit stops for minimum and maximum pressure.

**Dial:** aluminium, white with black markings.

**Pointer:** adjustable, aluminium, black.

### 1.32.3 - Filled Model

**Damping liquid:** glycerine 98%, silicon oil.

**Ambient temperature:**

$+32...+149\text{ }^{\circ}\text{F}$  ( $0...+65\text{ }^{\circ}\text{C}$ ) with glycerine filling;

$-40...+149\text{ }^{\circ}\text{F}$  ( $-40...+65\text{ }^{\circ}\text{C}$ ) with silicon oil filling.

**Process fluid temperature:** max  $+149\text{ }^{\circ}\text{F}$  ( $+65\text{ }^{\circ}\text{C}$ ).

**Other features:** as Fillable Model.

**bourdon tube "solid-front" pressure gauges, for high pressures  
turret case DS 4.5" (125 mm)**

**MGS32**

RC3 - 01/12

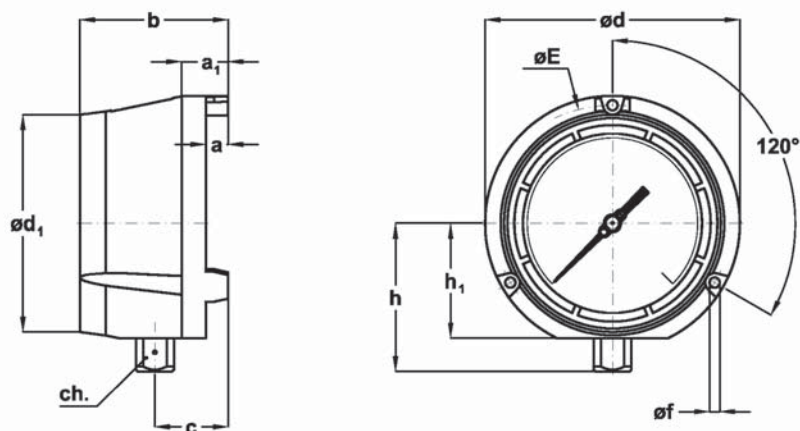

**A - LOWER CONNECTION**

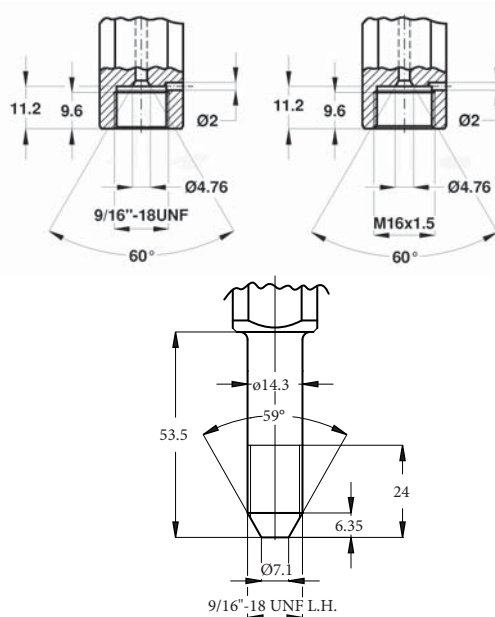

IN ORDER TO IMPROVE THEIR PRODUCTION, MESSRS. NUOVA FIMA RESERVE THE RIGHT TO THEMSELVES TO MAKE ALL THE MODIFICATIONS THAT THEY DEEM INDISPENSABLE AT ANY TIME. UPDATED DATA SHEETS ARE AVAILABLE ON SITE: [www.nuovafima.com](http://www.nuovafima.com)

Mounting	F	a	a <sub>1</sub>	b	c	d	d <sub>1</sub>	E	f	h	h <sub>1</sub>	ch	Peso (1)
Lower	<b>IUF</b> 9/16-18 UNF-2B (1)	13	27	86	42	148	126	137	6,5	86	66,5	22	0,75 kg
	<b>D7F</b> M16 x 1,5												
	<b>IUH</b> 9/16-18 UNF-L.H.												

dimensions : mm

- (1) adasuitable for following fittings:  
 1/4" F250C Autoclave  
 1/4" HF4 - HiP  
 1/4" Newport AMINCO HP  
 1/4" HP Butech  
 (2) add 1.10 lbs (0,5 kg) when filled.

**OPTIONS**

Model	fillable	filled
<b>F11</b> - Panel mounting kit	◆	◆
<b>P01</b> - Suitable for filling with silicon and "Fluorolube"	◆	
<b>S10</b> - Silicone filling		◆
<b>T01</b> - Tropicalization	◆	◆

**"HOW TO ORDER" SEQUENCE**

Section / Model/Case /Mounting/ Diameter / Range / Process connection / Options

**1 32 2 A F D7F F11...T01**  
**3 IUUF**

