

safety pressure gauges "solid-front" all stainless steel construction DS 4", 6" (100-150mm)



PED 2014/68/UE ATEX 2014/34/UE

These instruments are built in conformity with the construction and safety specifications of EN 837-1/S3 e ASME B40.1.

In case of leaks or break of the elastic element, the operator is protected by a solid separating wall placed on the front of the instrument and by the blow out back. They are usually used in the food, process, pharmaceutical, petrochemical industries and in conventional and nuclear power plants. The TIG welding between the case and the process socket, strengthens the instrument and assures a better tight in case of dampening fluid. The advantages of filling the case of the instrument with a dampening fluid are: reduced pointer fluctuation, reduced wear of rotating parts of the movement when pulsant vibrations and pulsations occur. Moreover condensation and corrosive atmospheres which could damage the internal parts are prevented.

1.20.1 - Standard Model

Design: EN837-1.

Safety designation: S3 as per EN 837-2.

Ranges: from 0...15 to 0...30000 psi (from 0...0,6 to 0...1600 bar or equivalent units).

Accuracy class: 1 as per EN 837-1

Ambient temperature:

-40...+149 °F (-40...+65 °C), IP55 housing (IEC 529);

-58...+149 °F (-50...+65 °C), vented IP67 housing (IEC 529).

Process fluid temperature: -40...+302 °F (-40...+150 °C).

Thermal drift: ±0,4 %/10 °C of range (starting from 68°F - 20°C).

Working pressure:

100% of FSV for static pressure;

90% of FSV for pulsating pressure.

Over pressure limit: 30% of FSV (max 12 hours).

Socket material: AISI 316L st.st.

Bourdon tube, seamless tube: AISI 316L st.st. for pressure ranges up to 20000 psi (0...1000 bar); Duplex st.st for range ≥ 20000 psi (0...1400 bar)

Case: stainless steel.

Ring: stainless steel, bayonet lock.

Blow out disk: stainless steel.

Window: safety glass (with external zero adjustment on request).

Movement: stainless steel with internal limit stops.

Dial: aluminium, white with black markings.

Pointer: adjustable, aluminium, black.

1.20.2 - Fillable Model - Lower connection only

Ambient temperature: -40...+149 °F (-40...+65 °C), IP 67 housing (IEC 529).

Pointer: not adjustable, aluminium, black.

Other features: as Standard Model.

1.20.3 - Filled Model - Lower connection only

Ranges: from 0...15 to 0...30000 psi (from 0...1 to 0...1600 bar or equivalent units)

Damping liquid: glycerine 98%, silicon oil or fluorinated fluid.

Ambient temperature:

+32...+149 °F (0...+65 °C) with glycerine filling;

-40...+149 °F (-40...+65 °C) with silicon oil filling and fluorinated fluid filling.

Process fluid temperature: max +149°F (+65 °C).

Protection degree: IP 67 as per IEC 529.

Pointer: not adjustable, aluminium, black.

Other features: as Standard Model.

INSTRUMENTS FOR OXYGEN - Glycerine or silicone should not be used with highly oxidizing agents such as oxygen, chlorine, nitric acid or hydrogen peroxide, because of danger of spontaneous chemical reaction, inflammability or explosion. The use of fluorinated fluid is recommended in these cases.

safety pressure gauges "solid-front"
all stainless steel construction, DS4", 6" (100-150mm)

MGS20

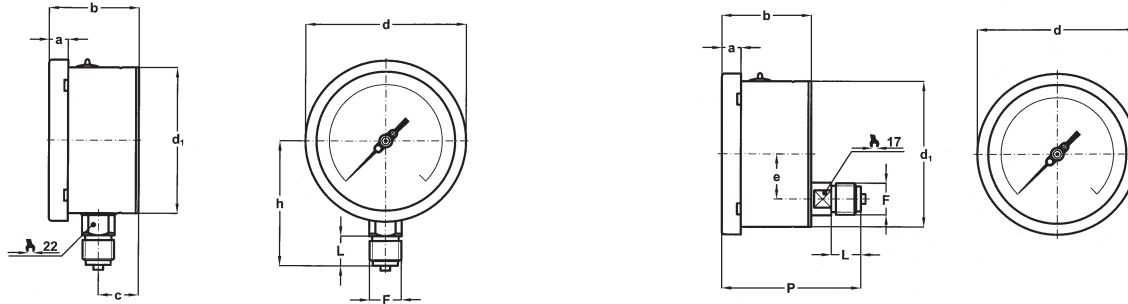

A - LOWER CONNECTION

D - BACK CONNECTION
- Standard model only

Mounting	DS	F	a	b	c	d	d ₁	e	h	p	L	Weight (1)
Lower	E 4" (100)	41M - G 1/2 A	0.51"	2.46"	1.16"	4.35"	3.97"		3.38"		0.78"	1.43 lbs
		43M - 1/2-14 NPT	(13)	(62,5)	(29,5)	(110,6)	(101)		(86)		(20)	(0,65 kg)
Lower	G 6" (150)	41M - G 1/2 A	0.59"	2.51"	1.18"	6.33"	5.92"		0.59"		0.78"	2.64 lbs
		43M - 1/2-14 NPT	(15)	(64)	(30)	(161)	(150,5)		(15)		(20)	(1,2 kg)
Back	E 4" (100)	41M - G 1/2 A	0.51"	2.46"		4.35"	3.97"	1.22"		3.75"	0.78"	1.54 lbs
		43M - 1/2-14 NPT	(13)	(62,5)		(110,6)	(101)	(31)		(95,5)	(20)	(0,70 kg)
Back	G 6" (150)	41M - G 1/2 A	0.59"	2.51"		6.33"	5.92"	1.22"		3.77"	0.78"	2.53 lbs
		43M - 1/2-14 NPT	(15)	(64)		(161)	(150,5)	(31)		(96)	(20)	(1,15 kg)

dimensions : inches (mm)

(1) add 0.95 lbs (0,43 kg) for DS 4" (100) and 1.76 lbs (0,8 kg) for DS 6" (150), when filled

OPTIONS

Model	standard	fillable	filled
C - Back flange, for lower connection pressure gauges	◆	◆	◆
E - Front flange, for back connection pressure gauges	◆		
2G1 - ATEX version II 2G c	<i>Constructive characteristics and ordering guide please refer to the relevant ATEX version data sheet.</i>		
2D1 - ATEX version II 2GD c			
C40 - AISI 316L st. st. case, ring and blow out disk	◆	◆	◆
K06 - Accuracy class: 0,6 as per EN 837-1 (1)	◆	◆	
P01 - Suitable for filling with silicon and fluorinated fluid		◆	
P02 - Oxygen service (4)	◆	◆ (2)	◆ (3)
P03 - Compensating device, for DS 4" (100 mm) only, lower mounting	◆	◆	◆
S10 - Silicone filling			◆
F30 - Fluorinated fluid filling			◆
ECV - Vented housing version, Ambient temperature -50...+65 °C (5) (6)	◆		
E67 - Protection degree IP67 (7)	◆		
T01 - Tropicalization	◆	◆	◆

(1) For pressure ranges up to 6000 psi (400 bar). Not available for receivers.

(2) to be ordered with instruments suitable for fluorinated fluid filling

(3) to be ordered with fluorinated fluid filled instruments

(4) For pressure ranges up to 15000 psi (1000 bar)

(5) to be ordered with E67 option

(6) lower mounting and not adjustable pointer

(7) to be ordered with ECV option

"HOW TO ORDER" SEQUENCE

Section / Model / Case / Mounting / Diameter / Range / Process connection / Options

1 20 1 A E 41M C, E
2 D G 43M 2G1...T01
3

RC6 - 05/14

IN ORDER TO IMPROVE THEIR PRODUCTION, MESSRS. NUOVA FIMA RESERVE THE RIGHT TO THEMSELVES TO MAKE ALL THE MODIFICATIONS THAT THEY DEEM INDISPENSABLE AT ANY TIME. UPDATED DATA SHEETS ARE AVAILABLE ON SITE: www.nuovafima.com

