

# **F113-P**

## **FLOW RATE MONITOR / TOTALIZER**

**with high / low alarms, analog and pulse outputs**

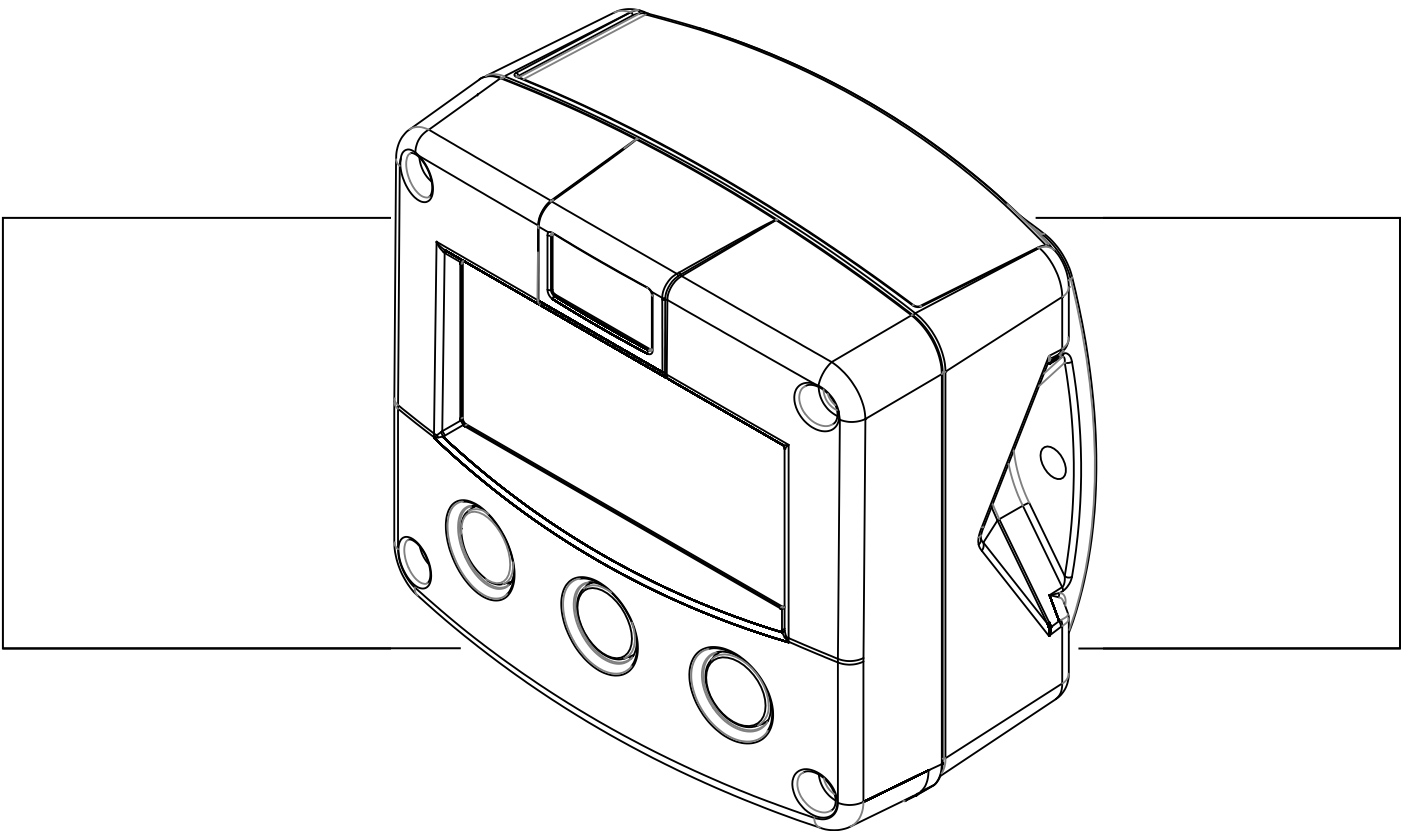

***Signal input flowmeter: pulse, Namur and coil***

***Signal outputs: 4-20mA ref. flow rate and pulse ref. total***

***Alarm outputs: maximum four flow rate alarms***

***Options: Intrinsically Safe, Modbus communication, external reset***





## SAFETY INSTRUCTIONS

- **Any responsibility is lapsed if the instructions and procedures as described in this manual are not followed.**
- **LIFE SUPPORT APPLICATIONS: The F113-P is not designed for use in life support appliances, devices, or systems where malfunction of the product can reasonably be expected to result in a personal injury. Customers using or selling these products for use in such applications do so at their own risk and agree to fully indemnify the manufacturer and supplier for any damages resulting from such improper use or sale.**
- **Electro static discharge does inflict irreparable damage to electronics! Before installing or opening the unit, the installer has to discharge himself by touching a well-grounded object.**
- **This unit must be installed in accordance with the EMC guidelines (Electro Magnetic Compatibility).**
- **Do connect a proper grounding to the metal enclosure as indicated if the F113-P has an incoming power line which carries a 115-230V AC. The Protective Earth (PE) wire may never be disconnected or removed.**
- **Intrinsic safe applications: follow the instructions as mentioned in Chapter 5 and consult "Fluidwell F1...-XI - Documentation for Intrinsic safety".**

## DISPOSAL OF ELECTRONIC WASTE



- The WEEE Directive requires the recycling of disposed electrical and electronic equipment in the European Union. When the WEEE Directive does not apply to your region, we support its policy and ask you to be aware on how to dispose of this product.
- The crossed out wheellie bin symbol as illustrated and found on our products tells that this product shall not be disposed of into the general waste system or into a landfill.
- At the end of its life, equipment shall be disposed of according to the local regulations regarding waste of the electrical and the electronic equipment.
- Please contact your local dealer, national distributor or the manufacturer's Technical helpdesk for information on the product disposal.



## SAFETY RULES AND PRECAUTIONARY MEASURES

- The manufacturer accepts no responsibility whatsoever if the following safety rules and precautions instructions and the procedures as described in this manual are not followed.
- Modifications of the F113-P implemented without preceding written consent from the manufacturer, will result in the immediate termination of product liability and warranty period.
- Mounting, electrical installation, start-up and maintenance of this device may only be carried out by trained persons authorized by the operator of the facility. Persons must read and understand this manual before carrying out its instructions.
- This device may only be operated by persons who are authorized and trained by the operator of the facility. All instructions in this manual are to be observed.
- Check the mains voltage and information on the manufacturer's plate before installing the unit.
- Check all connections, settings and technical specifications of the various peripheral devices with the F113-P supplied.
- Open the enclosure only if all leads are free of potential.
- Never touch the electronic components (ESD sensitivity).
- Never expose the system to heavier conditions than allowed according the classification of the enclosure (see manufacture's plate and chapter 4).
- If the operator detects errors or dangers, or disagrees with the safety precautions taken, then inform the owner or principal responsible.
- The local labor and safety laws and regulations must be adhered to.

## ABOUT THE MANUAL

This manual is divided into two main sections:

- The daily use of the unit is described in chapter 2 "Operation". These instructions are meant for users.
- The following chapters and appendices are exclusively meant for electricians/technicians. These provide a detailed description of all software settings and hardware installation guidance.

This manual describes the standard unit as well as the available options. For additional information, please contact your supplier.

**A hazardous situation may occur if the F113-P is not used for the purpose it was designed for or is used incorrectly. Please carefully note the information in this manual indicated by the pictograms:**



A "**warning !**" indicates actions or procedures which, if not performed correctly, may lead to personal injury, a safety hazard or damage of the F113-P or connected instruments.



Caution !

A "**caution !**" indicates actions or procedures which, if not performed correctly, may lead to personal injury or incorrect functioning of the F113-P or connected instruments.



Note !

A "**note !**" indicates actions or procedures which, if not performed correctly, may indirectly affect operation or may lead to an instrument response which is not planned.

## WARRANTY AND TECHNICAL SUPPORT

For warranty and technical support for your Fluidwell products, visit our internet site [www.fluidwell.com](http://www.fluidwell.com) or contact us at [support@fluidwell.com](mailto:support@fluidwell.com).

Hardware version : 03.01.xx  
Software version : 03.03.xx  
Manual : FW\_F113P\_v1702\_02\_EN  
© Copyright 2017 : Fluidwell B.V. - the Netherlands

**Information in this manual is subject to change without prior notice. The manufacturer is not responsible for mistakes in this material or for incidental damage caused as a direct or indirect result of the delivery, performance or use of this material.**

**© All rights reserved. No parts of this publication may be reproduced or used in any form or by any means without written permission of your supplier.**

## CONTENTS MANUAL

Safety instructions .....	3
Disposal of electronic waste.....	3
Safety rules and precautionary measures.....	3
About the manual .....	4
Warranty and technical support .....	4
Contents manual .....	4
1. Introduction .....	6
1.1. System description .....	6
2. Operational .....	7
2.1. Control panel .....	7
2.2. Operator information and functions .....	7
3. Configuration .....	9
3.1. How to program the F113-P .....	9
3.1.1. Setup menu - Settings .....	11
3.1.2. Explanation of Setup menu 1 - Total .....	12
3.1.3. Explanation of Setup menu 2 - Flow rate .....	12
3.1.4. Explanation of Setup menu 3 - Alarm.....	13
3.1.5. Explanation of Setup menu 4 - Display .....	13
3.1.6. Explanation of Setup menu 5 - Power management.....	14
3.1.7. Explanation of Setup menu 6 - Flowmeter .....	14
3.1.8. Explanation of Setup menu 7 - Analog output.....	15
3.1.9. Explanation of Setup menu 8 - Relays .....	16
3.1.10. Explanation of Setup menu 9 - Communication (option).....	17
3.1.11. Explanation of Setup menu A - Others .....	17
4. Installation .....	18
4.1. General directions.....	18
4.2. Installation / surrounding conditions .....	18
4.3. Dimensions- Enclosure.....	19
4.4. Installing the hardware .....	21
4.4.1. General installation guidelines.....	21
4.4.2. Aluminum enclosure - Field mounted .....	22
4.4.3. Aluminum enclosure - Panel mounted.....	22
4.4.4. Plastic (GRP) enclosure .....	23
4.4.5. Terminal connectors .....	24
4.4.6. Sensor supply .....	24
5. Intrinsically safe applications .....	32
5.1. Terminal connectors Intrinsic safe applications.....	34
5.2. Configuration Examples .....	36
5.3. Battery replacement instructions .....	38
5.3.1. Safety instructions .....	38
5.3.2. Replace the battery (hazardous area) .....	38
5.3.3. Disposal of batteries .....	38
6. Maintenance .....	39
6.1. General directions.....	39
6.2. Repair .....	39
6.3. Repair policy .....	39
Appendix A. Technical specification .....	40
Appendix B. Problem solving .....	43
Appendix C. Communication variables .....	44
Appendix D. Declaration of Conformity .....	48
Index of this manual .....	49
List of figures in this manual.....	50

# 1. INTRODUCTION

## 1.1. SYSTEM DESCRIPTION

### Functions and features

The function of the F113-P is to show the flow rate, the total, the accumulated total and to generate a scaled pulse according the accumulated total. The F113-P also can monitor the flow rate and generate the related flow rate alarm signals.

This product has been designed with a focus on:

- ultra-low power consumption to allow long-life battery powered applications (type PB/PC),
- intrinsic safety for use in hazardous applications (type XI),
- several mounting possibilities with aluminum or GRP enclosures for harsh industrial surroundings;
- ability to process all types of flowmeter signals,
- transmitting possibilities with analog / pulse / alarm and communication outputs.

### Flowmeter input

This manual describes the unit with a pulse\_input from the flowmeter. Other versions are available to process (0)4-20mA signals.

One flowmeter with a passive or active pulse, Namur or sine wave (coil) signal output can be connected to the F113-P. To power the sensor, several options are available.

### Standard outputs

- Max. four configurable alarm outputs: flow rate alarm, high-, low-, high-high- or low-low-flow rate alarm. Switched as long as the flow rate is too high or too low.
- Pulse output to transmit a pulse that represents a totalized quantity as programmed.
- Linear (0)4-20mA or 0-10V analog output to represent the actual flow rate as programmed. The (0)4-20mA or 0-10V signal limits can be tuned.

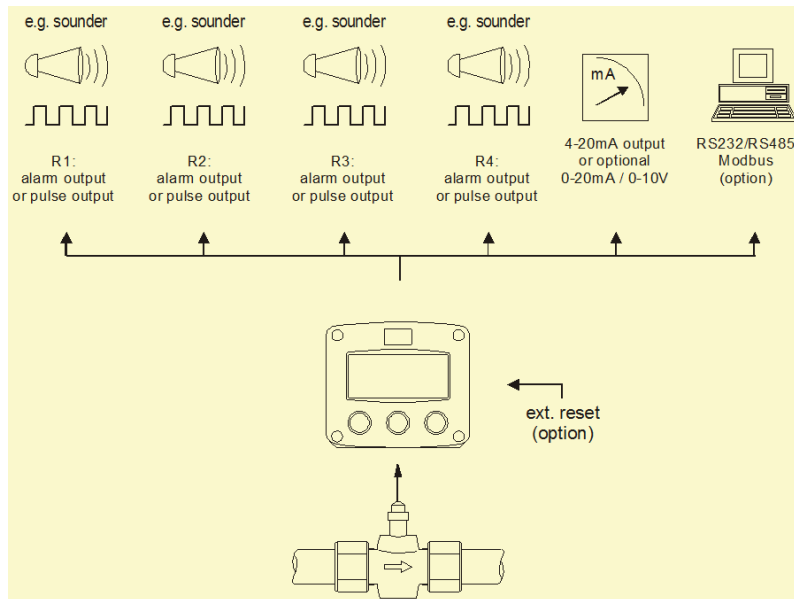

**Fig. 1: Typical application**

### Configuration of the unit

The F113-P is designed for use in many types of applications. For that reason, a setup menu is available to program the F113-P according to your specific requirements.

The setup includes several important features, such as K-Factors, engineering units, signal selection, power management (to extend battery life-time), etc. All settings are stored in a non-volatile memory and therefore kept in the event of a power failure or an exhausted battery.

### Display information

The unit has a LCD with (optional) backlight to show the process information, status and alarm messages. The display refresh rate is programmed in the setup menu. At a key press, the display refresh rate will switch to FAST for 30 seconds. When 'OFF' is selected, the display goes off after 30 seconds after the last key press. The display temporarily comes on after a key press.

### Options

The following options are available: isolated or active (0)4-20mA / 0-10V analog output, full Modbus communication RS232/485/TTL (also battery powered), intrinsic safety, mechanical relay or active output, power- and sensor-supply options, panel -mount, wall-mount and weather-proof enclosures, flame proof enclosure and LED backlight.

## 2. OPERATIONAL



Caution!

- This device may only be operated by persons who are authorized and trained by the operator of the facility. All instructions in this manual are to be observed.
- Take careful notice of the "Safety rules, instructions and precautionary measures" in the front of this manual.

This chapter describes the daily use of the F113-P . This instruction is meant for users / operators.

### 2.1. CONTROL PANEL

The control panel has three keys. The available keys are:



Fig. 2: Control Panel

#### Functions of the keys



This key is used to program and save new values or settings.  
The PROG/ENTER key is also used to gain access to the setup menu (read chapter 3).



This key is used to select the accumulated total and the alarm messages.  
The SELECT/▲ key is also used to increase a value after the PROG/ENTER key has been pressed (read chapter 3).



This key is used to reset the total.  
The CLEAR/▶ key is also used to select a digit or an option after the PROG/ENTER key has been pressed (read chapter 3).

### 2.2. OPERATOR INFORMATION AND FUNCTIONS

In general, the F113-P operates in the operator mode. The shown information depends on the settings which are made in the setup menu. The signal from the connected sensor is processed by the F113-P in the background, independent from the selected display refresh rate.



Fig. 3: Process information (typical)

**For the Operator, the following functions are available:**

#### ▪ Display flow rate / total or flow rate

This is the main display information of the F113-P. After the selection of any other information, it will always return to this main display automatically. Total is shown on the upper line of the display and flow rate on the bottom line. When selected in the setup menu, the display shows the flow rate only. When you press the select key, the total shows momentarily.

When "-----" is shown, then the flow rate value is too high to be displayed. The arrows ⇄ indicate the increase/decrease of the flow rate trend.

#### ▪ Clear total

The value for total can be reset. To do so, press the CLEAR/▶ key twice. When the key is pressed once, the text "PUSH CLEAR" is shown. To avoid a reset at this stage, press another key other than the CLEAR/▶ key or wait for 20 seconds. A reset of the total does not influence the accumulated total.

Type IB: When a Normally Closed (NC) contact is used, the local clear total function is disabled and a clear total is only possible with the external reset command.

▪ **Display accumulated total**

When the SELECT/▲ key is pressed, total and accumulated total are shown. The accumulated total cannot be reset. The value will count up to 99,999,999,999. The unit and number of decimals are shown according to the settings for the total.

▪ **How to program the alarm thresholds**

The F113-P can give an alarm message on the display. When set to on, at the same time, the digital outputs can give a signal for processing by an external device. Note that it is also possible to set or change the alarm thresholds from the setup menu.



*This procedure is applicable to all the alarm thresholds. Only the procedure for ALARM LL is given. From any operator page, press the SELECT/▲ key, to find the required submenu.*

Action	Result	Remark
1	From any operator page, press the SELECT/▲ key, to find the submenu: ALARM LL.	• The submenu shows: ALARM LL. -
2	Press the PROG/ENTER key to access the submenu: ALARM LL.	• The PROGRAM indicator blinks continuously. If you wait too long, the program mode goes off and changes are not saved, this is normal behavior.
3	Use the SELECT/▲ key to increase the digit. Use the CLEAR/▶ key to go to the next number.	• The PROGRAM indicator blinks continuously. • You can select the required alarm threshold. The 0 (zero) in front of the number will not show when the setting is saved. The alarm is only shown on the display. For an alarm on an external device, set also the function of the digital output.
4	Press the PROG/ENTER key to confirm the selection.	• The PROGRAM indicator goes off. • The selection is saved. • The display shows the selected alarm threshold. If you do not press the PROG/ENTER key to confirm, your selection is not saved.

▪ **Flow rate alarm**

When the actual flow rate is outside the allowed range, the F113-P can give an alarm message on the display. When set to on, at the same time, the digital outputs can give a signal for processing by an external device. The alarm is terminated automatically as soon as the flow rate is within its range again.

▪ **Low-battery alarm**



*Only use original batteries. Original batteries can be ordered at the manufacturer. The use of unapproved batteries will void the warranty.*

At the end of the battery's life-time, the voltage starts to drop. When the voltage becomes too low, the battery indicator comes on. When the battery indicator is on, install a new and fresh battery as soon as possible.



**Fig. 4: Low-battery alarm (typical)**

▪ **Alarm**

When the alarm indicator is shown, refer to Appendix B: Problem Solving.



### 3. CONFIGURATION

This and the following chapters are exclusively meant for electricians and non-operators. In these, an extensive description of all software settings and hardware connections are provided.



Caution !

- Mounting, electrical installation, start-up and maintenance of this device may only be carried out by trained persons authorized by the operator of the facility. Persons must read and understand this manual before carrying out its instructions.
- This device may only be operated by persons who are authorized and trained by the operator of the facility. All instructions in this manual are to be observed.
- Make sure, the measuring system is correctly wired up according to the wiring diagrams. Protection against accidental contact is no longer assured when the housing cover is removed or the panel cabinet has been opened (danger from electrical shock). The housing may only be opened by trained persons authorized by the operator of the facility.
- Take careful notice of the "Safety rules, instructions and precautionary measures" in the front of this manual.

The setup menu is used to program the F113-P.

The setup menu is accessible at all times while the F113-P remains fully operational. Be aware that in this case any change to the settings may have an influence on the operation.



Note !

*It is possible to prevent access to the setup menu with a password. A password may be required to enter the setup menu. Without this password, access is denied.*

#### 3.1. HOW TO PROGRAM THE F113-P

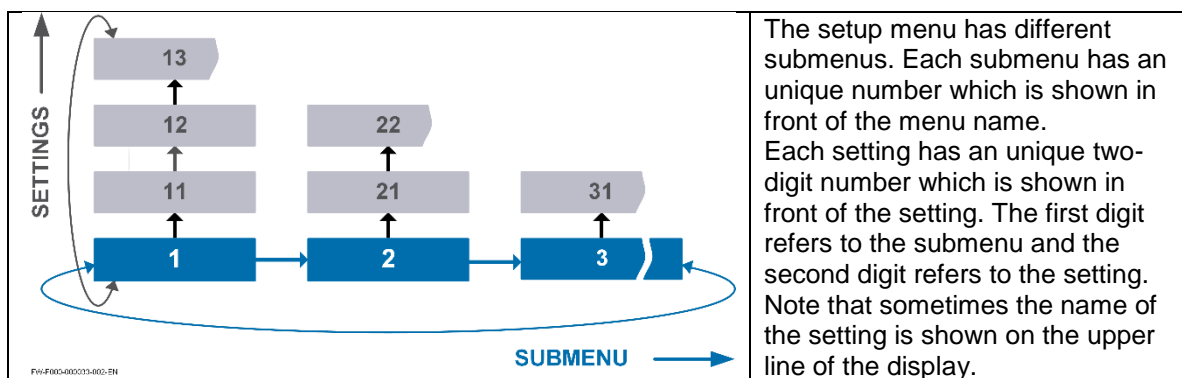

##### How to enter the setup menu

When the setup menu is protected by a password, the F113-P asks for a password to access the setup menu. When in the operator mode, press and hold the PROG/ENTER key for 7 seconds to access the setup menu.

##### How to navigate in the setup menu

The setup menu has different submenus to program the F113-P. For navigation, the submenus and the settings are identified with numbers (for the submenu: e.g. 1; for the setting: e.g. 12.).

The CLEAR/ ▶ key and the PROG/ENTER key are used for navigation. The explanation assumes that you are in the submenu TOTAL.

Action	Result	Remark	
1	Press the CLEAR/ ▶ key to select the next submenu.	• The submenu FLOW RATE shows	-
2	Press again to go to the next submenu.	• The submenu DISPLAY shows.	-
3	Momentarily, press the PROG/ENTER key to select the previous submenu.	• The submenu FLOW RATE shows	The PROG/ENTER key is used as a ◀ key.
4	Press again to go to the previous submenu.	• The submenu TOTAL shows	The PROG/ENTER key is used as a ◀ key.

The SELECT/▲ key and the CLEAR/▶ key are used for navigation.

The explanation assumes that you are in the submenu TOTAL. When you are:

- in the first setting and you navigate to the previous setting, the F113-P goes back to the related main menu.
- in the last setting and you navigate to the next setting, the F113-P goes to the related main menu.

Action	Result	Remark
1 Press the SELECT/▲ key to select the first setting.	• The setting UNIT shows.	-
2 Press the SELECT/▲ key again to go to the next setting.	• The setting DECIMALS shows.	-
3 Press the CLEAR/▶ key to select the previous setting.	• The setting UNIT shows.	-
4 Press the CLEAR/▶ key again to go to the previous setting.	• The submenu TOTAL shows	This is normal behavior because the setting UNIT is the first setting of the submenu TOTAL.

### How to make a setting



Caution !

Changes are only saved when you press the PROG/ENTER key.



The explanation assumes that you are in the submenu TOTAL and the setting UNIT. When you do not want to save the change, wait for approximately 20 seconds or press and hold the PROG/ENTER key for approximately 3 seconds.

Action	Result	Remark
1 Momentarily, press the PROG/ENTER key.	• The PROG indicator blinks. • The engineering unit L shows.	To access the setting.
2 Press the SELECT/▲ key to select the next engineering unit.	• The PROG indicator blinks. • The engineering unit m <sup>3</sup> shows.	If you wait too long, the program mode goes off and changes are not saved, this is normal behavior.
3 Press the SELECT/▲ key to select the next engineering unit.	• The PROG indicator blinks. • The engineering unit US GAL shows.	-
4 Press the CLEAR/▶ key to select the previous engineering unit	• The PROG indicator blinks. • The engineering unit m <sup>3</sup> shows.	-
5 To confirm the changes: Momentarily, press the PROG/ENTER key.	• The PROG indicator goes off. • The change is saved. • The engineering unit m <sup>3</sup> shows.	If you do not press the PROG/ENTER key to confirm, your selection is not saved.
To discard the changes: Press and hold the PROG/ENTER key for approximately 3 seconds.	• The PROG indicator goes off. • The change is discarded. • The engineering unit L shows.	-

## 3.1.1. SETUP MENU - SETTINGS

<b>1</b>	<b>TOTAL</b>		
	11	unit	L; m <sup>3</sup> ; kg; lb; GAL; USGAL; bbl; no unit
	12	decimals	0000000; 111111.1; 22222.22; 3333.333
	13	K-factor:	0.000010 - 9999999
	14	decimals K-factor	0 - 6
<b>2</b>	<b>FLOW RATE</b>		
	21	unit	mL; L; m <sup>3</sup> ; mg; g; kg; ton; gal; bbl; lb; cf; rev; - - - - (no unit); scf; nm <sup>3</sup> ; nL; p
	22	time	/sec; /min; /hour; /day
	23	decimals	0000000; 111111.1; 22222.22; 3333.333
	24	K-factor	0.000010 - 9,999,999
	25	decimals K-factor	0 - 6
	26	calculation	per 1 - 255 pulses
	27	cut-off	0.1 - 999.9 seconds
<b>3</b>	<b>ALARM</b>		
	31	flowzero	default; no relay; ignore
	32	alarm ll	0000.000 - 9999999
	33	alarm lo	0000.000 - 9999999
	34	alarm hi	0000.000 - 9999999
	35	alarm hh	0000.000 - 9999999
	36	delay ll	0.1 - 999.9
	37	delay lo	0.1 - 999.9
	38	delay hi	0.1 - 999.9
	39	delay hh	0.1 - 999.9
<b>4</b>	<b>DISPLAY</b>		
	41	function	total; rate
	42	alarm set	operator; setup; hidden
	43	light	0% (off); 20%; 40%; 60%; - 80%; 100% (full brightness)
	44	bl alarm	off; on; flash
<b>5</b>	<b>POWER MANAGEMENT</b>		
	51	LCD new	fast; 1 sec; 3 sec; 15 sec; 30 sec; off
	52	battery mode	operational; shelf
<b>6</b>	<b>FLOWMETER</b>		
	61	signal	npn; npn-lp; reed; reed-lp; pnp; pnp-lp; namur; coil-hi; coil-lo; 8-1 DC; 12 DC; 24 DC
<b>7</b>	<b>ANALOG</b>		
	71	output	disable; enable
	72	rate-min	0000.000 - 9999999
	73	rate-max	0000.000 - 9999999
	74	cut-off	0.0 - 9.9%
	75	tune-min	0 - 9999
	76	tune-max	0 - 9999
	77	filter	00 - 99
<b>8</b>	<b>RELAYS</b>		
	81	relay 1	off; lo-lo; lo; hi; hi-hi; all; pulse
	82	relay 2	off; lo-lo; lo; hi; hi-hi; all; pulse
	83	relay 3	off; lo-lo; lo; hi; hi-hi; all; pulse
	84	relay 4	off; lo-lo; lo; hi; hi-hi; all; pulse
	85	width	0.001 - 9.999
	86	decimals	0.001 - 9
	87	amount	0.001 - 9999999
<b>9</b>	<b>COMMUNICATION</b>		
	91	speed	1200; 2400; 4800; 9600
	92	address	1 - 247
	93	mode	bus-rtu; bus-asc; off
<b>A</b>	<b>OTHERS</b>		
	A1	model	F113-P
	A2	software version	nn:nn:nn
	A3	serial no.	nnnnnnn
	A4	password	0000 - 9999
	A5	tag-nr	0000000 - 9999999

## 3.1.2. EXPLANATION OF SETUP MENU 1 - TOTAL

<b>UNIT</b> <b>11</b>  Note !	<p>This setting is used to select the engineering unit for the indication of the total, the accumulated total and the pulse output.</p> <p><b>When you change the engineering unit, you must recalculate and reprogram the K-factor for the (accumulated) total. When you recalculate and reprogram the K-Factor, the history for (accumulated) total is not correct anymore, because the (accumulated) total is not recalculated. For future reference, best practice is to make a note of the accumulated total before you program the recalculated K-Factor.</b></p>
<b>DECIMALS</b> <b>12</b>	<p>This setting is used to set the amount of digits behind the decimal point for the (accumulated) total indication.</p>
<b>K-FACTOR</b> <b>13</b>  Note !	<p>This setting is used to set the K-Factor for the total. With the K-Factor, the flowmeter pulse signals are converted to a quantity. The K-Factor is based on the number of pulses generated by the flowmeter per selected engineering unit, for example m<sup>3</sup>. A more accurate K-Factor (more decimals, as set in decimals K-Factor) allows for a more accurate operation of the system.</p> <p><b>Example 1: Calculating the K-Factor.</b>          The flowmeter generates 2.4813 pulses per liter and the selected unit is m<sup>3</sup>. A cubic meter consists of 1000 liter which gives 2.4813 pulses*1000 liter=2481.3 pulses per m<sup>3</sup>. So, the K-Factor is 2481.3. Enter for the Flowmeter K-Factor: 24813 and for the flowmeter K-Factor decimals: 1.</p> <p><b>Example 2: Calculating the K-Factor.</b>          The flowmeter generates 6.5231 pulses per gallon and the selected engineering unit is gallons. So, the K-Factor is 6.5231. Enter for the Flowmeter K-Factor: 65231 and for the Flowmeter K-Factor decimals: 4.</p> <p><b>When you recalculate and reprogram a new K-Factor, the history for (accumulated) total is not correct anymore, because the (accumulated) total is not recalculated. For future reference, best practice is to make a note of the accumulated total before you program the recalculated K-Factor.</b></p>
<b>DECIMALS K-FACTOR</b> <b>14</b>	<p>This setting is used to set the amount of digits behind the decimal point for the K-Factor.</p>

## 3.1.3. EXPLANATION OF SETUP MENU 2 - FLOW RATE

The settings for total and flow rate are entirely separate. In this way, different engineering units can be used for each e.g. cubic meters for total and liters for flow rate.

<b>UNIT</b> <b>21</b>  Note !	<p>This setting is used to select the engineering unit for the indication of the flow rate.</p> <p><b>Alteration of the engineering unit will have consequences for operator and setup values, they will not be automatically recalculated to the value of the new selected unit. The K-Factor has to be adapted as well; the calculation is not done automatically.</b></p>
<b>TIME</b> <b>22</b>	<p>This setting is used to set the time unit for the flow rate calculation. Note that the flow rate is given in engineering unit/time unit, e.g. liters/minute (l/min).</p>
<b>DECIMALS</b> <b>23</b>	<p>When you change this setting, also recalculate and change the settings for the analog rate-min and analog rate-max.</p>
<b>K-FACTOR</b> <b>24</b>	<p>This setting is used to set the amount of digits behind the decimal point for the flow rate indication.</p>
<b>DECIMALS K-FACTOR</b> <b>25</b>	<p>This setting is used to set the K-Factor for the flow rate. With the K-Factor, the flowmeter pulse signals are converted to a quantity. The K-Factor is based on the number of pulses generated by the flowmeter per selected engineering unit, for example m<sup>3</sup>. A more accurate K-Factor (more decimals, as set in decimals K-Factor) allows for a more accurate operation of the system.</p>

<b>CALCULATION</b> 26	The flow rate is calculated by measuring the time between a number of pulses, for example 10 pulses. The more pulses the more accurate the flow rate will be. The maximum value is 255 pulses. This setting does influence the update interval for the flowrate and thus, indirectly the update interval of the analog output.. (maximum update 10 times a second). If the output response is too slow, decrease the number of pulses. For low frequency applications (< 10Hz): do not program more than 10 pulses, else the update time will be very slow. <i>For high frequency applications (&gt; 1kHz): do program 50 or more pulses.</i>
<b>CUT-OFF</b> 27	This setting is used to set the threshold for a minimum flow. If during this time less than XXX-pulses are generated (refer to Calculation), the flow rate will be shown as zero. The cut-off has to be entered in seconds.

### 3.1.4. EXPLANATION OF SETUP MENU 3 - ALARM

These settings determine how the flow rate is monitored and how the F113-P will process the alarm conditions. For the setup of the configurable outputs, refer to setup menu: Relays.

<b>FLOWZERO</b> 31	When the flow rate is zero, then it is possible to ignore or disable the flow rate monitoring. The following settings can be selected: DEFAULT: in case of a low-flow rate alarm and zero flow, it will switch the alarm output and indicate the alarm on the display. NO RELAY: in case of a low-flow rate alarm and zero flow, it won't switch the alarm output but will indicate the alarm on the display only. IGNORE: in case of a low-flow rate alarm and zero flow, it won't switch the alarm output and nothing will be indicated on the display.
<b>ALARM LL</b> 32	This setting is used to activate the related alarm condition and to set the threshold value for a this flow alarm. The setting 0.0 disables this alarm.
<b>ALARM LO</b> 33	This submenu is used to activate the related alarm condition and to set the threshold value for a this flow alarm. The setting 0.0 disables this alarm.
<b>ALARM HI</b> 34	This setting is used to activate the related alarm condition and to set the threshold value for a this flow alarm. The setting 0.0 disables this alarm.
<b>ALARM HH</b> 35	This setting is used to activate the related alarm condition and to set the threshold value for a this flow alarm. The setting 0.0 disables this alarm.
<b>DELAY LL</b> 36	This setting is used to set a delay time for the related alarm. When the alarm condition is still valid after the delay time, an alarm is given.
<b>DELAY LO</b> 37	This setting is used to set a delay time for the related alarm. When the alarm condition is still valid after the delay time, an alarm is given.
<b>DELAY HI</b> 38	This setting is used to set a delay time for the related alarm. When the alarm condition is still valid after the delay time, an alarm is given.
<b>DELAY HH</b> 39	This setting is used to set a delay time for the related alarm. When the alarm condition is still valid after the delay time, an alarm is given.

### 3.1.5. EXPLANATION OF SETUP MENU 4 - DISPLAY

<b>FUNCTION</b> 41	This setting can be set to display total or rate. <ul style="list-style-type: none"> <li>When 'total' is selected, simultaneously, total is shown with the large digits and flow rate with the smaller digits. When SELECT is pressed, the accumulated total is shown temporarily.</li> <li>When 'rate' is selected, only flow rate will be shown with the large digits together with its measuring unit. When SELECT is pressed, the total and the accumulated total are shown temporarily.</li> </ul>
<b>ALARM SET</b> 42	This setting is used to determine in which menu you can change the alarm settings. When programmed for setup menu only, the alarm settings in the operator menu are read-only.
<b>LIGHT</b> 43	The backlight brightness can be adjusted from 0% (off) to 100% (full brightness) in steps of 20%. When the F113-P is only loop powered, the backlight is disabled. An external power supply is required to supply the backlight.
<b>BL ALARM</b> 44	This setting is used to set the behavior of the backlight (bl) during an alarm condition.

### 3.1.6. EXPLANATION OF SETUP MENU 5 - POWER MANAGEMENT

When used with the internal battery option (type PB/PC), the user can expect reliable measurement over a long period of time. The F113-P has several smart power management functions to extend the battery life time significantly. Two of these functions can be set.

<b>LCD NEW</b> <b>51</b>	<p>The calculation of the display-information influences the power consumption significantly. When the application does not require a fast display refresh rate, it is strongly advised to select a slow refresh rate. Please understand that NO information will be lost; every pulse will be counted and the output signals will be generated in the normal way. At a key press, the display refresh rate will switch to FAST for 30 seconds. When 'OFF' is selected, the display goes off after 30 seconds after the last key press. The display temporarily comes on after a key press.</p> <p><b>Example battery life-time with a coil pick-up:</b></p> <ul style="list-style-type: none"> <li>• 1kHz pulse and FAST update: about 2 years;</li> <li>• 1kHz pulse and 1 sec update: about 5 years.</li> </ul>
<b>BATTERY MODE</b> <b>52</b>	<p>The F113-P has two modes: operational or shelf. After "shelf" has been selected, the F113-P can be stored for several years; it will not process the sensor signal; the display is switched off but all settings and totals are stored. In this mode, power consumption is extremely low. To wake up the F113-p again, press the select/▲ key two times.</p>





### 3.1.7. EXPLANATION OF SETUP MENU 6 - FLOWMETER

<b>SIGNAL</b> <b>61</b>	 Note !	<p>With this setting the type of flowmeter output is selected. The settings with LP (low-pass) filter are used to apply a build-in noise reduction. Selections "active pulse" offer a detection level of 50% of the supply voltage.</p>		
TYPE OF SIGNAL	EXPLANATION	RESISTANCE	FREQ. / mV	REMARK
NPN	NPN input	100 kΩ pull-up	max.6 kHz.	(open collector)
NPN - LP	NPN with low pass filter	100 kΩ pull-up	max.1.2 kHz.	(open collector) less sensitive
REED	Reed-switch input	1 MΩ pull-up	max.1.2 kHz.	
REED - LP	Reed-with low pass filter	1 MΩ pull-up	max.120 Hz.	Less sensitive
PNP	PNP input	100K pull-down	max.6 kHz.	
PNP - LP	PNP with low pass filter	100K pull-down	max.1.2 kHz.	Less sensitive
NAMUR	NAMUR input	820 Ω pull-down	max.4 kHz.	External power required
COIL-HI	High sensitive coil input	-	min. 20 mV <sub>pp</sub>	Sensitive for interference!
COIL-HI (option ZF)			min. 10 mV <sub>pp</sub>	
COIL-HI (option ZG)			min. 5 mV <sub>pp</sub>	
COIL LO	Low sensitive coil input	-	min. 80 mV <sub>pp</sub>	Normal sensitivity
8-1 DC	Active pulse input detection level 8.2V DC	3K9	max.10KHz.	External power required
12 DC	Active pulse input detection level 12V DC	4K	max.10KHz.	External power required
24 DC	Active pulse input detection level 24V DC	3K	max.10KHz.	External power required



### 3.1.8. EXPLANATION OF SETUP MENU 7 - ANALOG OUTPUT

A linear 4-20mA signal (option AB: 0-20mA or option AU: 0-10V) output signal is generated that represents the flowrate. The settings for the flow rate influence the analog output directly. The relationship between the flow rate and the analog output is set with the following settings.

<b>OUTPUT</b> <b>71</b>  Note !	If the analog output is not used, select disable to minimize the power consumption (e.g. save battery life-time). <i>Option AP: When a power supply is available but the output is disabled, a 3.5mA signal will be generated.</i>
<b>RATE-MIN</b> <b>72</b>	Enter here the flow rate at which the output should generate the minimum signal (0)4mA or 0V - in most applications at zero flow. The number of decimals shown depend upon setup 23. The engineering units/time (e.g. L/min) are dependent upon setup 21 and 22.
<b>RATE-MAX</b> <b>73</b>	Enter here the flow rate at which the output should generate the maximum signal (20mA or 10V) - in most applications at maximum flow. The number of decimals shown depend upon setup 23. The engineering units/time (e.g. L/min) are dependent upon setup 21 and 22.
<b>CUT-OFF</b> <b>74</b>	To ignore leakage of the flow for example, a low flow cut-off can be set as a percentage of the full range of 16mA, 20mA or 10V. When the flow is less than the required rate, the current will be the minimum signal (0)4mA or 0V. <b>Example:</b> Calculate the cut-off. Rate-min: 0L/min [4mA], Rate-max: 100 L/min [16mA], Cut-off: 2% <b>Required rate [L/min]:</b> (rate-max - rate-min)*cut-off: (100-0)*2%=2.0L/min <b>Output [mA]:</b> rate-min + (rate-max*cut-off): 4+(16*2%)=4.32mA
<b>TUNE-MIN</b> <b>75</b>   Note !	The (0)4mA or 0V value can be tuned precisely with this setting. The initial minimum analog output value is (0)4mA or 0V. However, this value might differ slightly due to ambient influences such as temperature for example. <b>Before tuning the signal, make sure that the analog signal is idle (not used) for any application!</b> After pressing PROG, the current will be about 4mA (0mA or 0V). The current can be increased / decreased with the arrow keys and is directly active. Press ENTER to store the new value. If required, you can program the analog output 'up-side-down'. The (0)4mA or 0V represents the maximum flow rate and the 20mA or 10V represents the minimum flow rate.
<b>TUNE-MAX</b> <b>76</b>   Note !	The 20mA or 10V value can be tuned precisely with this setting. The initial maximum analog output value is 20mA or 10V. However, this value might differ slightly due to ambient influences such as temperature for example. <b>Before tuning the signal, make sure that the analog signal is idle (not used) for any application!</b> After pressing PROG, the current will be about 20mA or 10V. The current can be increased / decreased with the arrow keys and is directly active. Press ENTER to store the new value. If required, you can program the analog output 'up-side-down'. The (0)4mA or 0V represents the maximum flow rate and the 20mA or 10V represents the minimum flow rate.
<b>FILTER</b> <b>77</b>	This setting is used to stabilize the output signal. With the help of this digital filter a more stable but less actual representation of the flow rate can be obtained. The filter principal is based on three input values: the filter level (01-99), the last calculated flow rate and the last average value. The higher the filter level, the longer the response time on a value change will be.

FILTER VALUE	RESPONSE TIME ON STEP CHANGE OF ANALOG VALUE. TIME IN SECONDS				
	INFLUENCE	50%	75%	90%	99%
01	filter disabled	filter disabled	filter disabled	filter disabled	filter disabled
02	0.1 sec	0.2 sec	0.4 sec	0.7 sec	0.7 sec
03	0.2 sec	0.4 sec	0.6 sec	1.2 sec	1.2 sec
05	0.4 sec	0.7 sec	1.1 sec	2.1 sec	2.1 sec
10	0.7 sec	1.4 sec	2.2 sec	4.4 sec	4.4 sec
20	1.4 sec	2.8 sec	4.5 sec	9.0 sec	9.0 sec
30	2.1 sec	4 sec	7 sec	14 sec	14 sec
50	3.5 sec	7 sec	11 sec	23 sec	23 sec
75	5.2 sec	10 sec	17 sec	34 sec	34 sec
99	6.9 sec	14 sec	23 sec	45 sec	45 sec



**3.1.9. EXPLANATION OF SETUP MENU 8 - RELAYS**

The outputs are configurable, they can be set to a specific alarm output, a scaled pulse output according accumulated total or to off (energy saving when not used).



Note !

*There are four outputs in the submenu, but the amount of outputs can vary due to regulations or chosen options. Standard, there are three outputs, option XI has only two outputs and option OS has four outputs.*

<b>RELAY 1</b> <b>81</b>  Note !	This setting is used to set the function of related output R1. Mind that when set to pulse, the output has a maximum frequency of 5Hz to prevent contact bounce. <i>For intrinsic safe applications (XI):                      The setting in this submenu is overridden by the setting of relay 3.</i>
<b>RELAY 2</b> <b>82</b>	This setting is used to set the function of related output R2. Mind that this output has a maximum frequency of 500Hz.
<b>RELAY 3</b> <b>83</b>  Note !	This submenu is used to set the function of related output R3. Mind that this output has a maximum frequency of 500Hz. <i>For intrinsic safe applications (XI):                      The setting of this output (fast output) is assigned to R1 (option XI has only two outputs).</i>
<b>RELAY 4</b> <b>84</b>	Only available for option OS: This submenu is used to set the function of related output R1. Mind that when set to pulse, the output has a maximum frequency of 5Hz to prevent contact bounce.
<b>WIDTH</b> <b>85</b>	The pulse width determines the time that the output will be active; in other words the pulse duration. Value “zero” will disable the pulse output. The pulse signal always has a 50% duty cycle, hence the minimum time between the pulses is equal to the pulse width setting. If the frequency should go out of range – when the flow rate increases for example – an internal buffer will be used to “store the missed pulses”: As soon as the flow rate slows down, the buffer will be “emptied”. It might be that pulses will be missed due to a buffer-overflow, so it is advised to program this setting within its range!
<b>DECIMALS</b> <b>86</b>	This setting is used to set the amount of digits behind the decimal point for the amount.
<b>AMOUNT</b> <b>87</b>	A pulse will be generated every time a certain quantity is added to the total. Enter this quantity here while taking the decimals for pulse into account.



**3.1.10. EXPLANATION OF SETUP MENU 9 - COMMUNICATION (OPTION)**

*This product is designed for the connection to a communication network. Products with a communication option do not include cyber security functions. Fluidwell cannot take any responsibility for the cyber security, omissions or errors in the communication safety. To maintain a secure operation, automation and control, it is the sole responsibility of the owner to install and manage the appropriate safety measures to protect the network, the product and the communication against any kind of security breaches.*

The functions described below deal with hardware that is not part of the standard delivery. Programming of these functions does not have any effect if this hardware has not been installed. Consult Appendix C and the Modbus communication protocol description for a detailed explanation.

<b>SPEED</b> 91	This setting is used to set the Baudrate.
<b>ADDRESS</b> 92	This setting is used to set the communication address for the F113-P.
<b>MODE</b> 93	This setting is used to set the Modbus transmission mode. Select OFF to disable the communication.

**3.1.11. EXPLANATION OF SETUP MENU A - OTHERS**

For support and maintenance it is important to have information about the characteristics of the F113-P . Your supplier will ask for this information when support is required.

<b>MODEL</b> A1	This setting shows the model name.
<b>SOFTWARE VERSION</b> A2	This setting shows the version number of the firmware (software).
<b>SERIAL NO</b> A3	This setting shows the serial number.
<b>PASSWORD</b> A4	This setting is used to set a password (pin code) to limit the access for the setup menu. Only persons who know the pin code can access the setup menu. The pin code 0000 disables the pin code to allow for access by any person.
<b>TAG-NR</b> A5	This setting is used to set a tag number for the F113-P.

## 4. INSTALLATION

### 4.1. General directions



- Mounting, electrical installation, start-up and maintenance of this device may only be carried out by trained persons authorized by the operator of the facility. Persons must read and understand this manual before carrying out its instructions.
- This device may only be operated by persons who are authorized and trained by the operator of the facility. All instructions in this manual are to be observed.
- Make sure, the measuring system is correctly wired up according to the wiring diagrams. Protection against accidental contact is no longer assured when the housing cover is removed or the panel cabinet has been opened (danger from electrical shock). The housing may only be opened by trained persons authorized by the operator of the facility.
- Take careful notice of the "Safety rules, instructions and precautionary measures" at the front of this manual.

### 4.2. INSTALLATION / SURROUNDING CONDITIONS

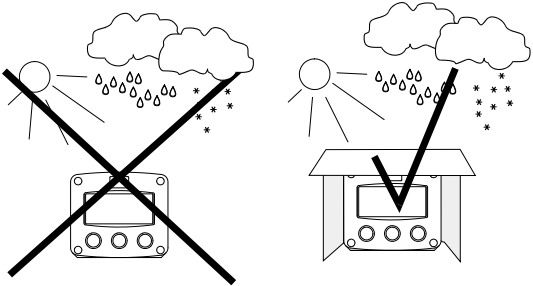

Take the relevant IP classification of the enclosure into account (see identification plate). Even an enclosure rated for IP67 / TYPE 4(X) should NEVER be exposed to strongly varying (weather) conditions.

**When panel-mounted, the front panel of the F113-P is rated for IP65 / TYPE 4(X)!**

When used in very cold surroundings or varying climatic conditions, inside the instrument case, take the necessary precautions against moisture.

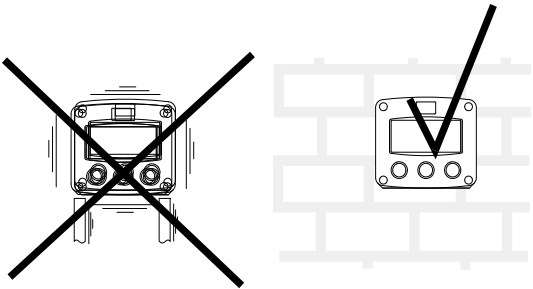

Mount the F113-P onto a solid structure to avoid vibrations.

4.3. DIMENSIONS- ENCLOSURE

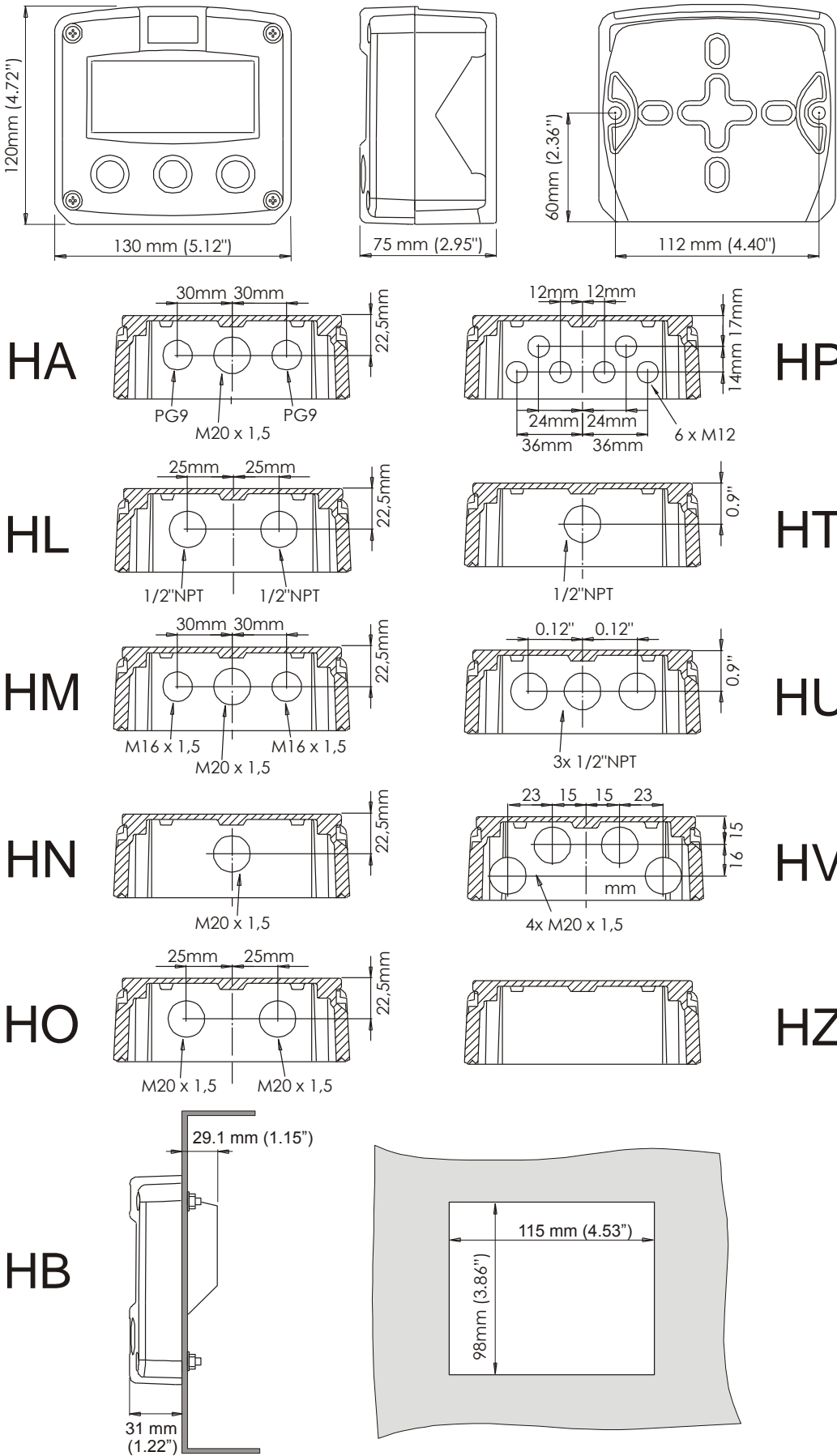

Fig. 5: Aluminum enclosures - Dimensions

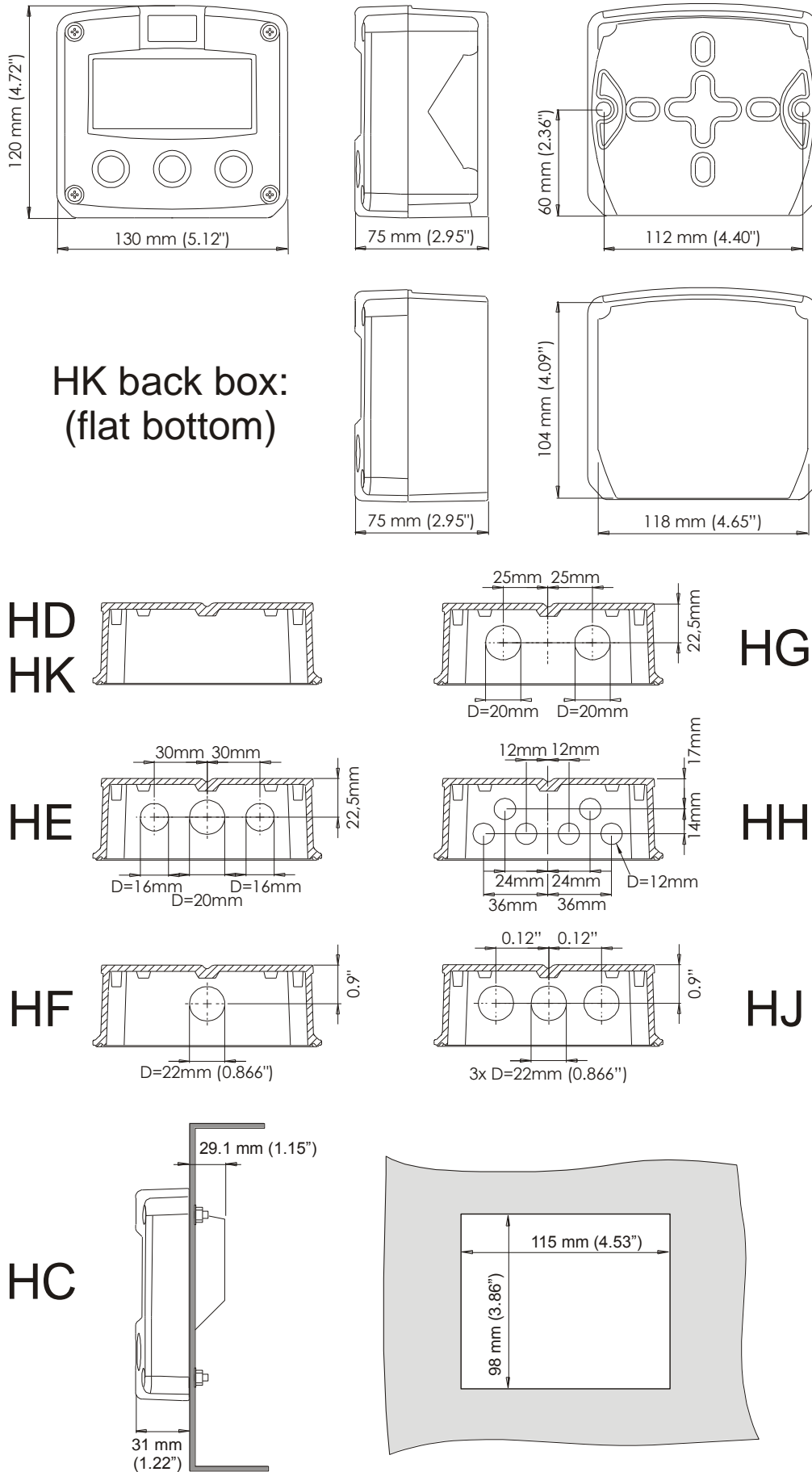

Fig. 6: GRP enclosures - Dimensions

#### 4.4. INSTALLING THE HARDWARE



- Electro static discharge does inflict irreparable damage to electronics! Before installing or opening the F113-P , the installer has to discharge himself by touching a well-grounded object.
- Do ground the aluminum enclosure properly as indicated. It is the responsibility of the installer to install, connect and test the Protective Earth connections in accordance with the (inter)national Rules and Regulations.
- This chapter shows general information regarding the electrical installation of the F113-P . Chapter 5 gives additional specific information regarding Intrinsic safe installation and overrules the information given in this chapter.



- When installed in an aluminum enclosure and a potentially explosive atmosphere requiring apparatus of equipment protection level Ga and Da, the unit must be installed such that, even in the event of rare incidents, an ignition source due to impact or friction sparks between the enclosure and iron/steel is excluded.

##### 4.4.1. GENERAL INSTALLATION GUIDELINES

- In the F113-P , different types of bonding and earthing are used. The common (ground) is mostly used for termination of the wire shields and the Protective Earth (PE) is used for electrical safety.
- The F113-P that came with a power module type PM; 110V-230V AC or type PD/PF with an option OR (the relays can handle 110V-230V AC) shall be connected to the Protective Earth (PE) stud which is installed in the metal back panel. The metal front panel is connected to the Protective Earth by the mounting screws and serrated washers.
- For V AC applications, the terminal 00 shall not be connected to avoid earth loops. For V DC applications, the terminal 00 shall be connected to the common (do NOT use for PE).
- The wire screens (shield) are meant to prevent electromagnetic interference and shall be, galvanic isolated, connected to the common ground terminals that belong to the specific sensor connection. The wire screens shall be terminated at one side to prevent wire loops. Inside of the Fluidwell unit, the different common ground terminals are connected to each other. It is advised, as illustrated, to terminate the wire screens in the vicinity of the sensor and to insulated the wire screen with a shrink tube at the Fluidwell unit side.
- The wire screens (shield) are meant to prevent electromagnetic interference and shall be, galvanic isolated, connected to the common ground terminals that belong to the specific sensor connection. The wire screens shall be terminated at one side to prevent wire loops. Inside of the Fluidwell unit, the different common ground terminals are connected to each other. It is advised, as illustrated, to terminate the wire screens in the vicinity of the sensor and to insulated the wire screen with a shrink tube at the Fluidwell unit side.
- Separate cable glands with effective IP67 / TYPE 4(X) seals for all wires.
- Unused cable entries: ensure that you fit IP67 / TYPE 4(X) plugs to maintain rating.
- A reliable ground connection for both the sensor, and if applicable, for the metal enclosure (above).
- An effective screened cable for the input signal, and grounding of its screen to the “⊥ “ terminal or at the sensor itself, whichever is appropriate to the application.

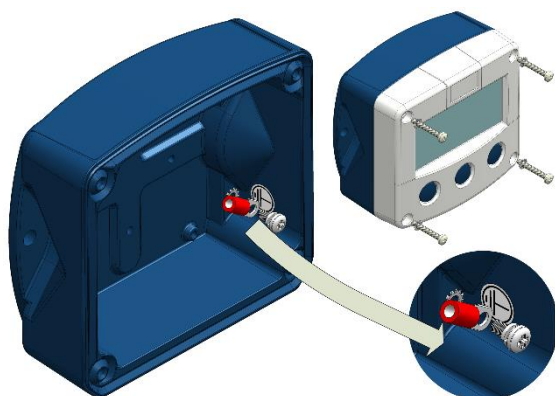

Field mounted

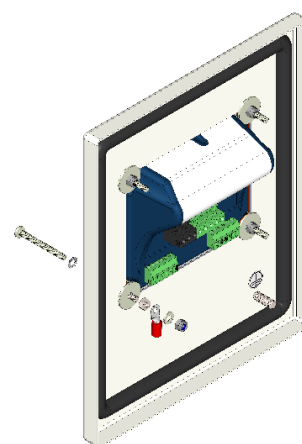

Panel mounted

4.4.2. ALUMINUM ENCLOSURE - FIELD MOUNTED



**Risk of damage to equipment!**

Do not use the terminal 00 to connect the protective earth wire, the 00 and the common ground terminals are internally connected. Be careful, to prevent damage to equipment when you connect different power supplies (sensor, PLC, etc.). Inside the Fluidwell display, the common grounds are internally connected to each other.

**The PE connection**

The PE connection is made with the PE stud inside the back panel and the 4 mounting screws that attach the cover to the back panel.

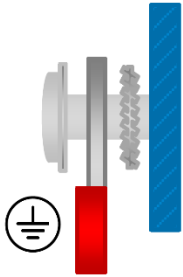

The PE connection in the metal back panel is made with a serrated washer, a terminal, a washer and a screw.

The PE connection to the metal cover is made with the serrated washers and the mounting screws.

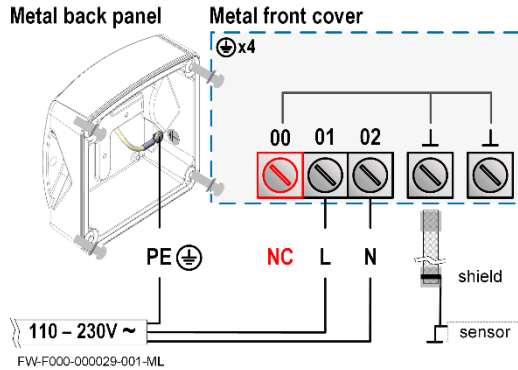

**Type PM (110-230V AC)**

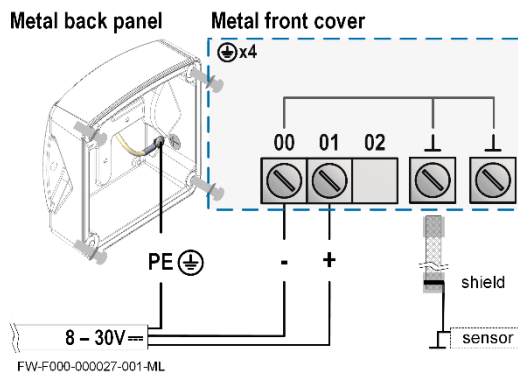

**Type OR (8-30V DC)**

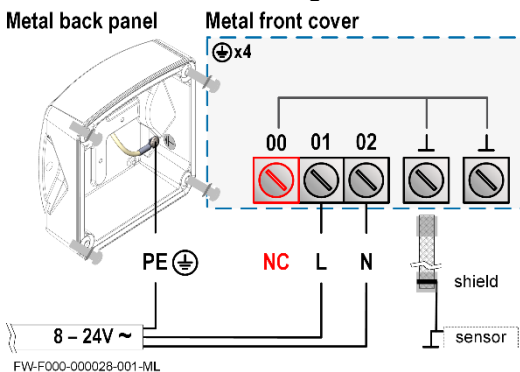

**Type OR (8-24V AC)**

4.4.3. ALUMINUM ENCLOSURE - PANEL MOUNTED

**The PE connection**

The PE connection is made with one of the mounting screws that attaches the front panel to the panel.

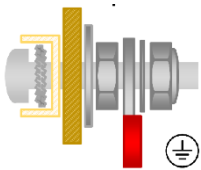

The PE connection to the metal cover is made with the serrated washers and the mounting screws.

The PE connection to the panel is made with the washer, the nut, the terminal, the washer and a lock nut.

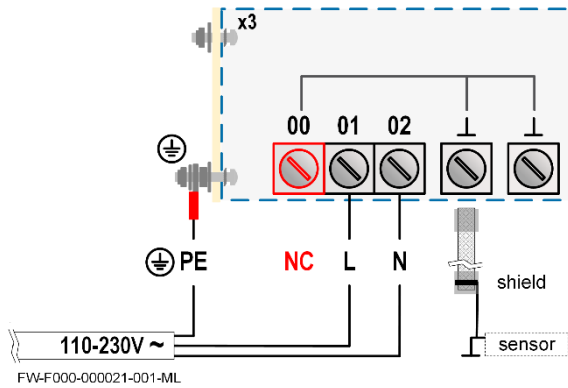

**Type PM (110-230V AC)**

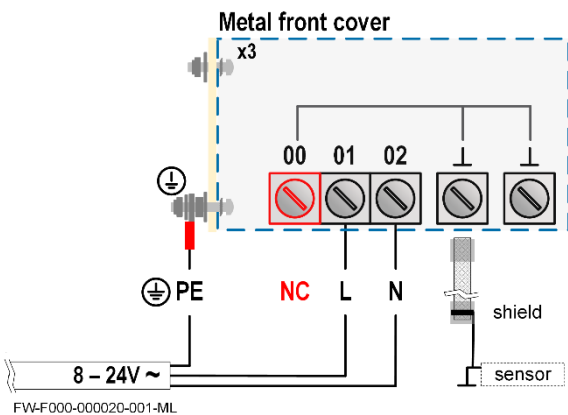

**Type OR (8-24V AC)**

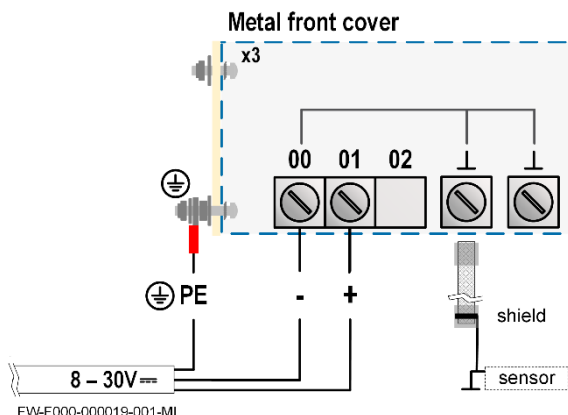

**Type OR (8-30V DC)**

#### 4.4.4. PLASTIC (GRP) ENCLOSURE

##### The PE connection

The F113-P in a GRP enclosure meets the requirements of class 2 (double insulated). Therefore the incoming PE wire is terminated with an insulating end cap.

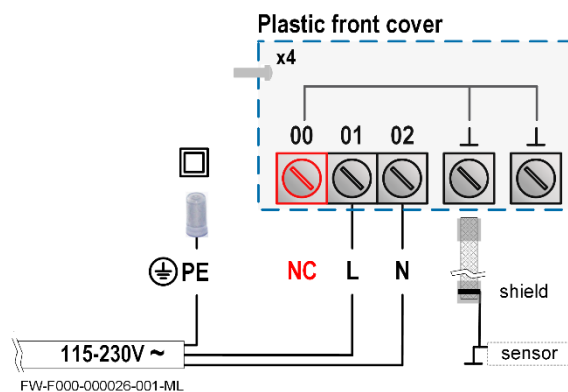

Type PM (110-230V AC)

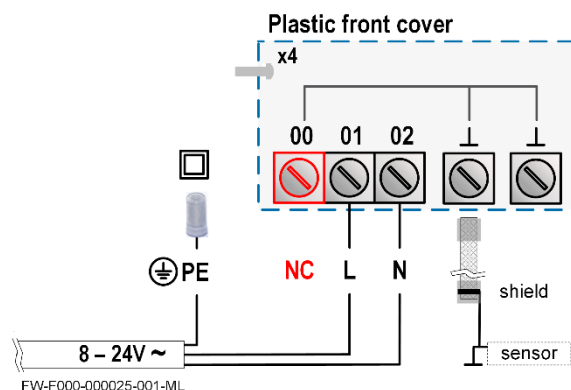

Type OR (8-24V AC)

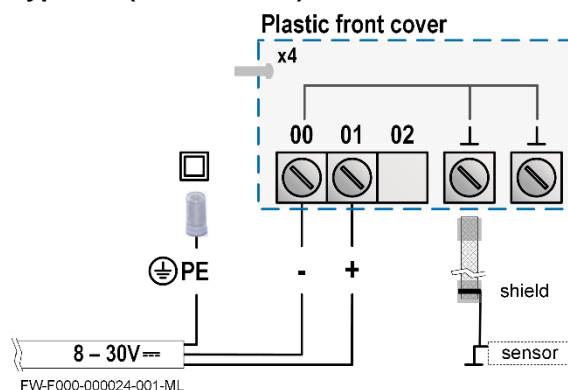



Type OR (8-30V DC)

**4.4.5. TERMINAL CONNECTORS**

Refer to Appendix A: Technical Specification

	Power supply			Alarm/Pulse Output 2		Alarm/Pulse Output 1		Analog Output		Sensor A Input		External Reset		Alarm/Pulse Output 3		
	00	01	02	03	04	05	06	07	08	09	10	11	12	13	15	16
PD; PF ~		L	N									+ ↓				
PD; PF ==	-	+										+ ↓				
PM ~		L	N									+ ↓				
PX ==	-	+										+ ↓				
P										⊥	↑					
OA; OT				⊥	↓	⊥	↓								⊥	↓
OR				com	NO	com	NO									
AA; AB; AI; AP								I-	I+							
AU								U-	U+							
A-PL										I-	I+					
IB													⊥	reset		

	PB; PC	Battery supply: 3.6V == (PX remains available, battery supply operates as back-up power)
	PX	Sensor supply A (11) by software setting (Coil; Reed)
	PD; PF; PM	Sensor supply A (11) by switch 1, 2, 3 and 4
		Fieldmount: use the PE terminal and the mounting screws/serrated washers. Panel mount: create a PE terminal by the mounting screws/serrated washers.

Communication (DTR = 12V DC)						
	26	27	28	29	30	31
CB	⊥	+ DTR	RxD↑	TxD↓		
CH	⊥		A	B		
CI	⊥		A	B	Y	Z

FW-F113-000001-001-EN

**Fig. 7: Overview of terminal connectors - Standard configuration and options**

**4.4.6. SENSOR SUPPLY**

**For type PB/PC; PX; AP:**

There is no real sensor supply out available. Only a limited power supply is available. This power supply MAY NOT be used to supply the flowmeters electronics, converters etc. as it will not provide adequate sustained power ! All energy used by the flowmeters pick-up will directly influence the battery life-time. It is strongly advised to use a "zero power" pickup such as a coil or reed-switch when operating without external power. It is possible to use some low power NPN or PNP output signals, but the battery life time will be significantly reduced (consult your distributor). The sensor supply is fixed: 1.2V DC or 3V DC (set by the firmware).

**For type PD; PF; PM:**

It is possible to supply the sensor with different voltages. You can set the voltage with the switches. Internal power is only applicable for low power sensors (Coil, Reed). External power is only available when the main external power supply is connected.

The sensor supply voltage is selectable: 1.2; 3; 8.2; 12 or 24V DC.



**Set the sensor supply**

1. Make the F113-P safe. If applicable, mind the battery power.
2. Open the F113-P and carefully remove the cable-connectors and the protective cover.
3. Find and set the switches and select the  $V_{out}$  as required.
4. Close the protective cover and install the cable connectors.
5. Close the F113-P .

**Risk of electrocution - High voltage!**

Make sure, all the leads to the terminals are disconnected from the F113-P and NEVER connect the mains power supply to the unit when the protection cover has been removed!

Type PD	Power supply in: 8-24V AC / 10-30V DC				
<p>FW-PD-000001-001-EN Switch location (typical)</p>	<b>Sensor A</b>		<b>V<sub>out</sub> selection</b>		<b>Sensor supply out</b>
	1	2	3	4	NOTE: Use an AC autotransformer (spartrafo) with galvanic isolation.
	int	-	off	off	Coil 1.2V DC; <1mA Reed 3V DC; <1mA
	ext	-	on on off	on off off	8.2V DC @8V <sub>in</sub> AC / 10V <sub>in</sub> DC 12V DC @10V <sub>in</sub> AC / 14V <sub>in</sub> DC 24V DC @18V <sub>in</sub> AC / 26V <sub>in</sub> DC
Type PF	Power supply in: 15-24V AC / 20-30V DC				
<p>FW-PFPM-000001-001-EN Switch location (typical)</p>	<b>Sensor A</b>		<b>V<sub>out</sub> selection</b>		<b>Sensor supply out</b>
	1	2	3	4	
	int	-	off	off	Coil 1.2V DC; <1mA Reed 3V DC; <1mA
	ext	-	on on off	on off off	8.2V DC @8V <sub>in</sub> AC / 10V <sub>in</sub> DC 12V DC @10V <sub>in</sub> AC / 14V <sub>in</sub> DC 24V DC @18V <sub>in</sub> AC / 26V <sub>in</sub> DC
Type PM	Power supply in: 115V - 230V AC				
<p>FW-PFPM-000001-001-EN Switch location (typical)</p>	<b>Sensor A</b>		<b>V<sub>out</sub> selection</b>		<b>Sensor supply out</b>
	1	2	3	4	
	int	-	off	off	Coil 1.2V DC; <1mA Reed 3V DC; <1mA
	ext	-	on on off	on off off	8.2V DC 12V DC 24V DC

**Fig. 8: Sensor supply voltage - Switch setting**

**Terminal 03-04; alarm / pulse output R2:**

This output is designed as a fast output with a maximum frequency of 500Hz. For the use with a mechanical relay and a continuous signal (pulse) it is recommended to use a maximum frequency of 0.5Hz to prevent an early end-of-life of the mechanical relay.

**Terminal 05-06; alarm / pulse output R1:**

This output is designed as a slow output with a maximum frequency of 500Hz. For the use with a mechanical relay and a continuous signal (pulse) it is recommended to use a maximum frequency of 0.5Hz to prevent an early end-of-life of the mechanical relay.

**Type OA**

An active 24V DC signal flow rate alarm output or pulse output is available with this option. Max. driving capacity 50mA@24V per output. (Requires power supply type PD/PF/PM).

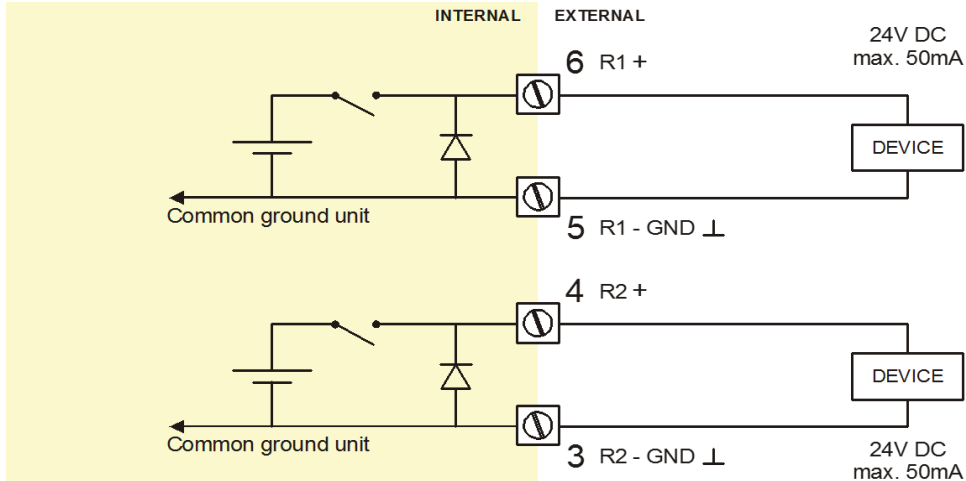

**Fig. 9: Terminal connections - Active output (typical)**

**Type OR:**

A mechanical relay output flow rate alarm output or pulse output is available with this option. Max. switch power 240V 0.5A per output. (Requires power supply type PD/PF/PM).

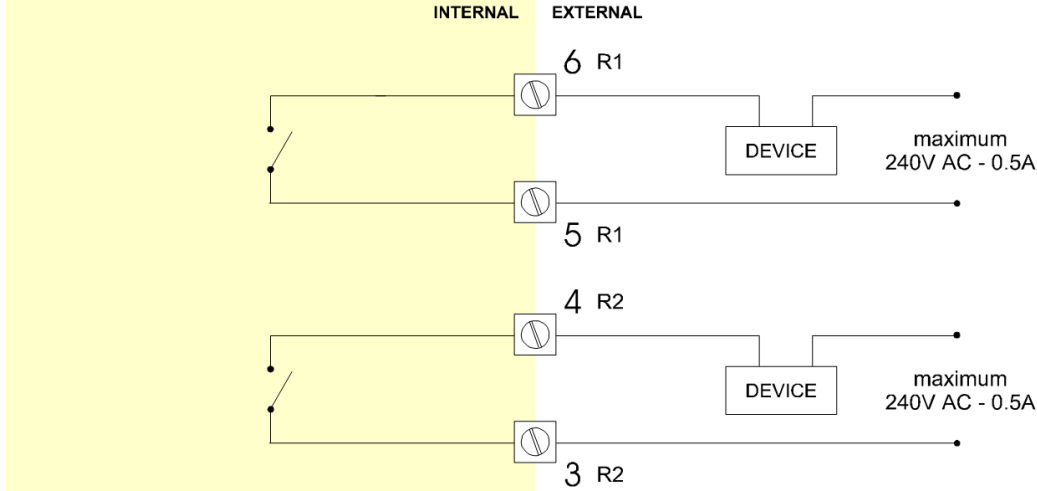

**Fig. 10: Terminal connections - Mechanical relay output (typical)**

**Type OT:**

A passive transistor output is available with this option. Max. driving capacity 300mA@50V DC.

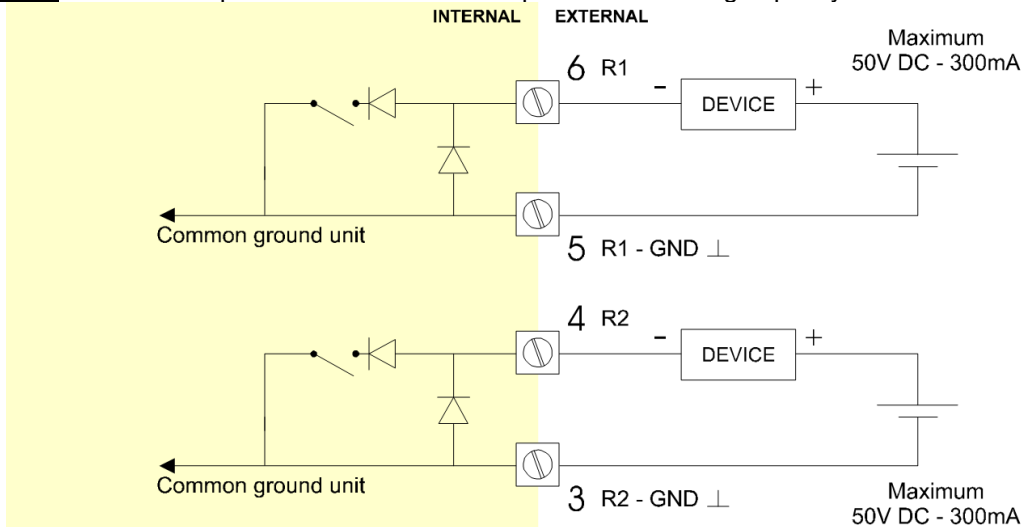

**Fig. 11: Terminal connections - Pulse output (typical)**

**Terminal 07-08; basic POWER SUPPLY - type AP - output loop powered:**

Connect an external power supply of 8-30VDC to these terminals or a (0)4-20mA loop. Do **connect** the "-" to terminal 7 and the "+" to terminal 8. When power is applied to these terminals, the (optional) internal battery will be disabled / enabled automatically to extend the battery life time.

**Terminal 07-08 analog output (SETUP 7) :**

An analog output signal proportional to the ratio is available as standard.

**Type AA:**

An active 4-20mA signal proportional to the flow rate is available with this option. When the output is disabled, a 3.5mA signal will be generated on these terminals. Max. driving capacity 1000 Ohm @ 24VDC. (Requires power supply type PD/PF/PM).

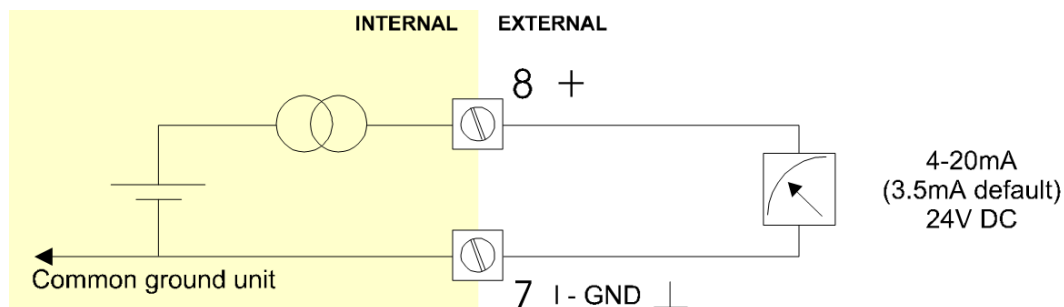

**Fig. 12: Terminal connections - 4-20mA analog output (typical)**

**Type AB:**

An active 0-20mA signal proportional to the flow rate is available with this option. Max. driving capacity 1000 Ohm @ 24VDC. (Requires power supply type PD/PF/PM).

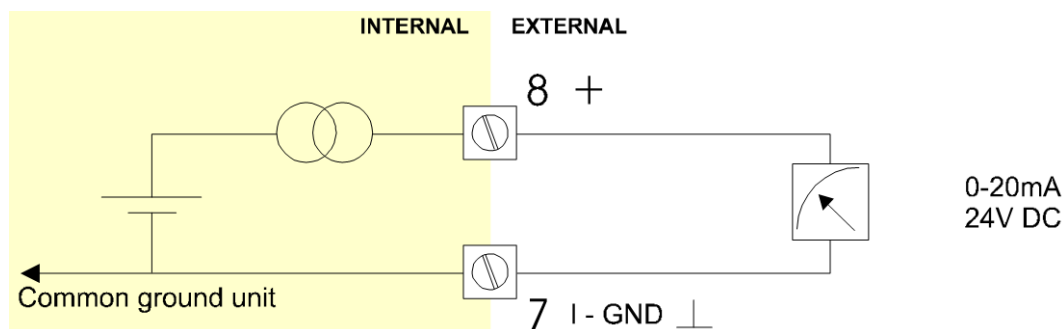

**Fig. 13: Terminal connections - Active 0-20mA analog output (typical)**

**Type AF:**

For the Intrinsically Safe floating 4-20mA signal: please read Chapter 5.

**Type AI:**

An isolated 4-20mA signal proportional to the flow rate is available with this option. When the output is disabled, a 3.5mA signal will be generated on these terminals. Max. driving capacity 1000 Ohm @ 30VDC. This option can be battery powered but the life time of the battery is about 2 -3 years.

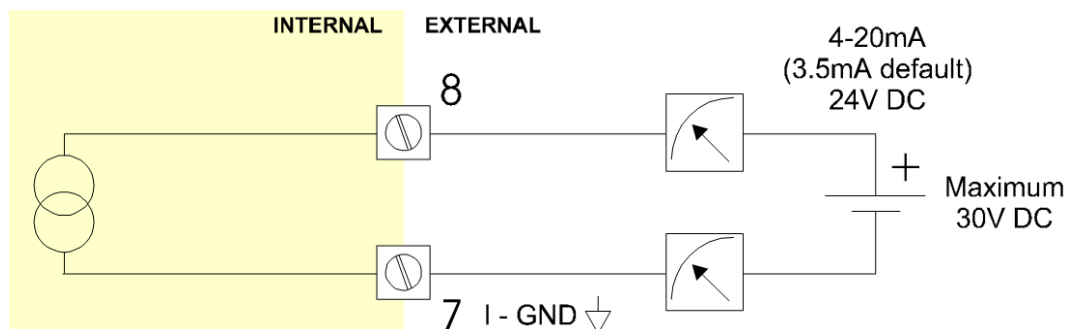

**Fig. 14: Terminal connections - Isolated 4-20mA analog output (typical)**

**Type AP:**

A passive 4-20mA signal proportional to the flow rate is available with this option. When a power supply is connected but the output is disabled, a 3.5mA signal will be generated. Max. driving capacity 1000 Ohm. This output does loop power the unit as well.

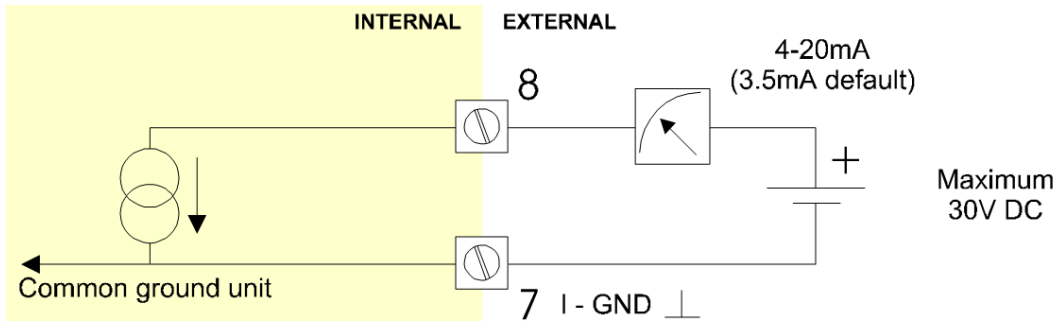

**Fig. 15: Terminal connections - Passive 4-20mA analog output (typical)**

**Type AU:**

A 0-10VDC signal proportional to the flow rate is available with this option. Max. load 10mA @ 10VDC. (Requires power supply type PD/PF/PM).

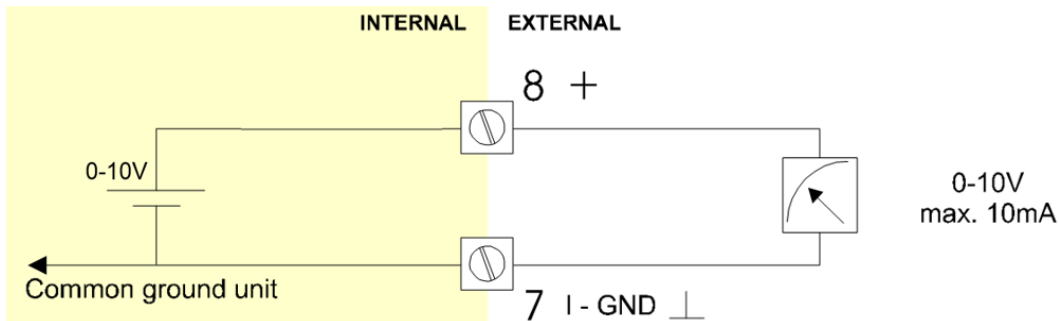

**Fig. 16: Terminal connections - Active 0-10V analog output (typical)**

**Terminal 09-11; Flowmeter input:**

Three basic types of flowmeter signals can be connected to the unit: pulse, active pulse or sine-wave (coil). The screen of the signal wire must be connected to the common ground terminal 09 (unless earthed at the sensor itself). The maximum input frequency is approximately 10 kHz (depending on the type of signal). The input signal type has to be selected in the flowmeter setup (read chapter 3).

**Sine-wave signal (Coil):**

The F113-P is suitable for use with flowmeters which have a coil output signal. Two sensitivity levels can be selected:

- COIL-LO: sensitivity from about 80mV<sub>pp</sub>;
- COIL-HI: sensitivity from about 20mV<sub>pp</sub>;
- type ZF, COIL-HI: sensitivity from about 10mV<sub>pp</sub>;
- type ZG, COIL-HI: sensitivity from about 5mV<sub>pp</sub>.

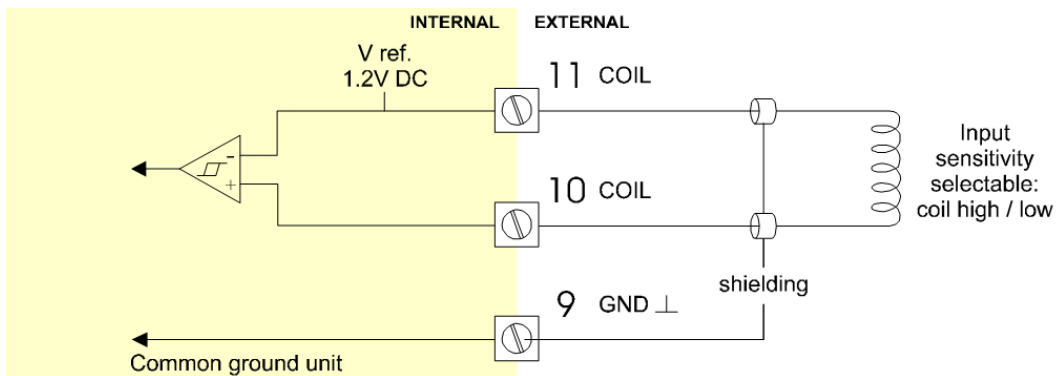

**Fig. 17: Terminal connections - Coil signal input (typical)**

**Pulse-signal NPN / NPN-LP:**

The F113-P is suitable for use with flowmeters which have a NPN output signal. For reliable pulse detection, the pulse amplitude has to go below 1.2V. Signal setting NPN-LP employs a low-pass signal noise filter, which limits the maximum input frequency - read par. 3.2.3.

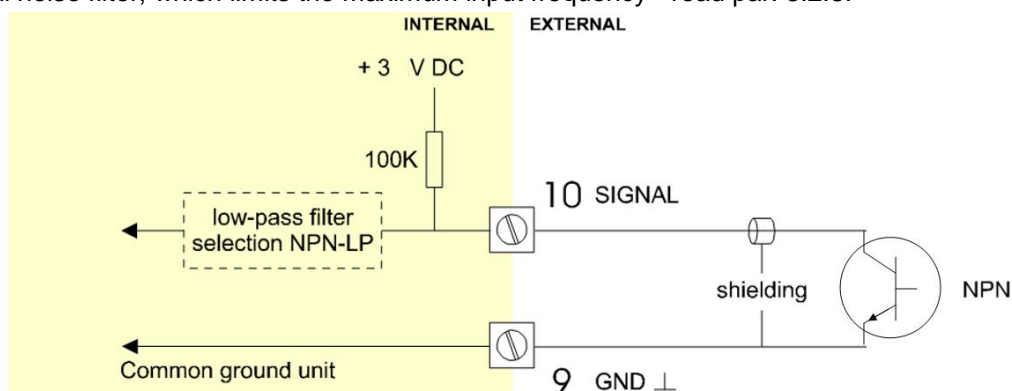
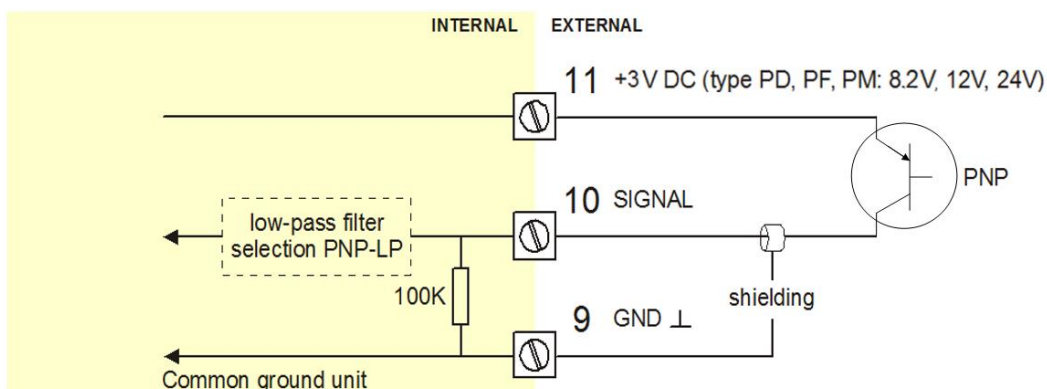

**Fig. 18: Terminal connections - NPN signal input (typical)**

**Pulse-signal PNP / PNP-LP:**

The F113-P is suitable for use with flowmeters which have a PNP output signal. 3V is offered on terminal 11 which has to be switched by the sensor to terminal 10 (SIGNAL). For a reliable pulse detection, the pulse amplitude has to go above 1.2V. Signal setting PNP-LP employs a low-pass signal noise filter, which limits the maximum input frequency (read chapter 3).

A sensor supply voltage of 8.2, 12 or 24V DC can be provided with power supply type PD, PF, PM. For a signal detection level of 50% of the supply voltage: please refer to "active signals".



**Fig. 19: Terminal connections - PNP signal input (typical)**

**Active signal 8.2V, 12V and 24V:**

If a sensor gives an active signal (read chapter 3). The detection levels are 50% of the selected supply voltage; approx. 4V (8-1 DC) or 6V (12 DC) or 12V (24 DC). Active signal selection may well be desired in case of power supply type PD, PF, PM is available for sensor supply.

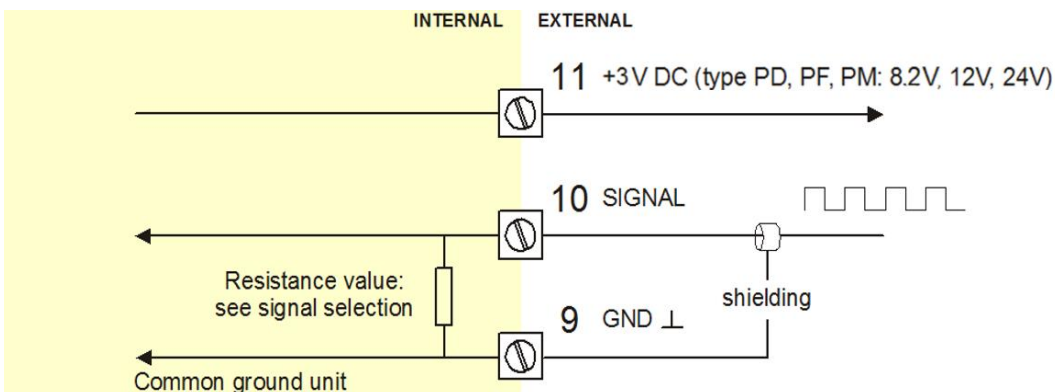

**Fig. 20: Terminal connections - Active signal input (typical)**

**Reed-switch:**

The F113-P is suitable for use with flowmeters which have a reed-switch. To avoid pulse bounce from the reed-switch, it is advised to select REED LP - low-pass filter (read chapter 3).

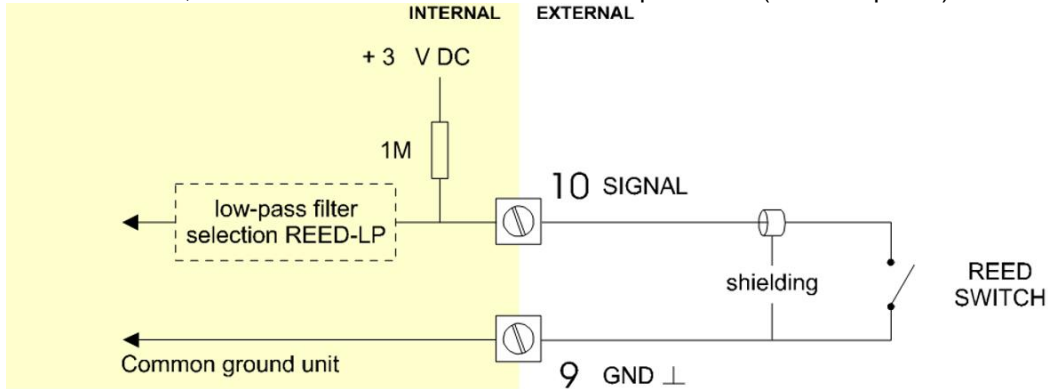

**Fig. 21: Terminal connections - Reed-switch signal input (typical)**

**NAMUR-signal:**

The F113-P is suitable for flowmeters with an Namur signal. The standard F113-P is not able to power the Namur sensor, as an external power supply for the sensor is required. However, a 8.2V sensor supply voltage (terminal 11) can be provided via types PD-PM.

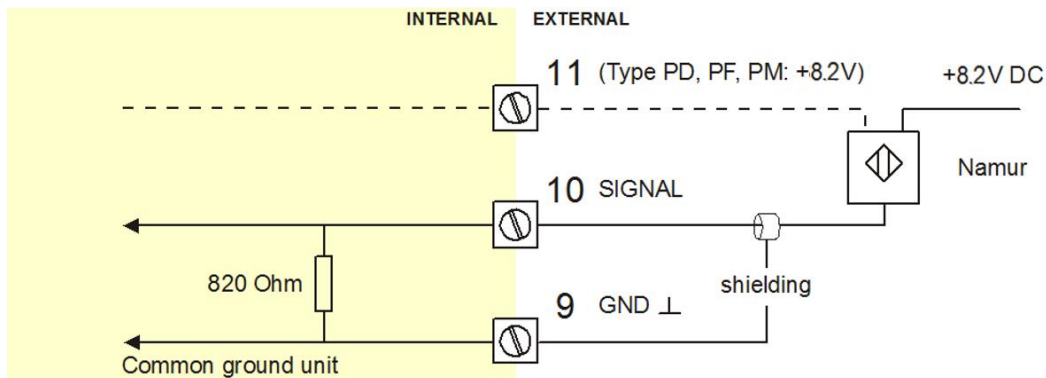

**Fig. 22: Terminal connections - NAMUR signal input (typical)**

**Type IB - Terminal 12-13; external reset:**

With this function the total can be reset to zero with an external switch. The Total resets only when the switch **opens**. When a Normally Closed (NC) contact is used, the local clear total function is disabled and a clear total is only possible with the external reset command. The input must be switched with a potential free contact to the terminal 12.

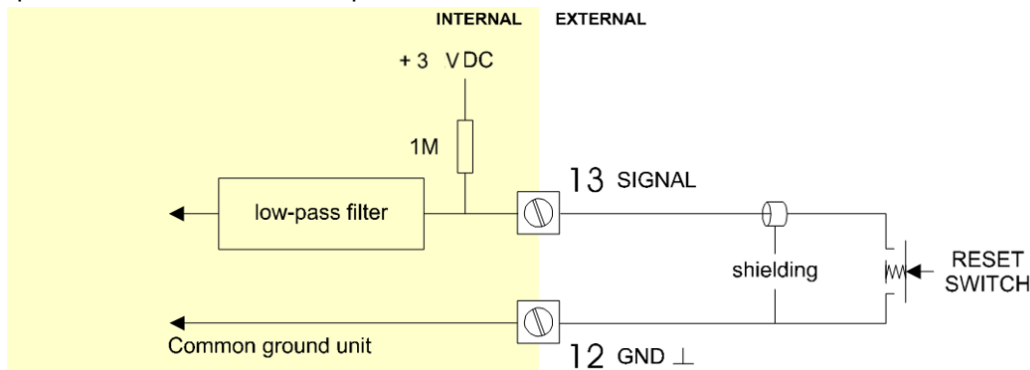

**Fig. 23: Terminal connections - External reset (typical)**

**Terminal 15-16; alarm / pulse output R3:**

This output is designed as a fast output with a maximum frequency of 500Hz. For the use with a mechanical relay and a continuous signal (pulse) it is recommended to use a maximum frequency of 0.5Hz to prevent an early end-of-life of the mechanical relay.

**Type OA:**

An active 24V DC signal flow rate alarm output is available with this option.

Max. driving capacity 50mA@24V per output. (Requires power supply type PD/PF/PM).

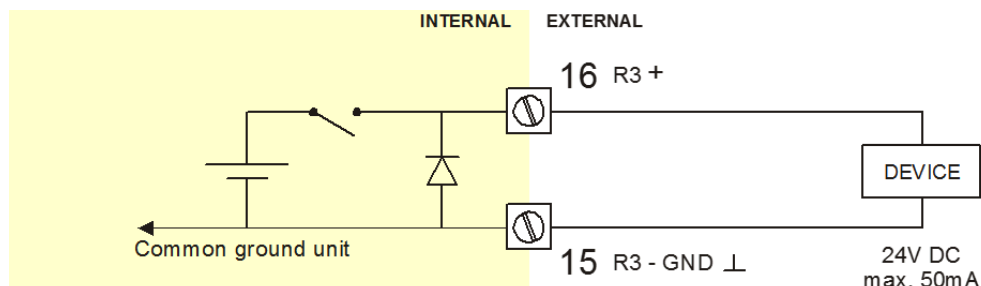

**Fig. 24: Terminal connections - Active output (typical)**

**Type OT:**

A passive transistor output is available with this option. Max. driving capacity 300mA@50V DC.

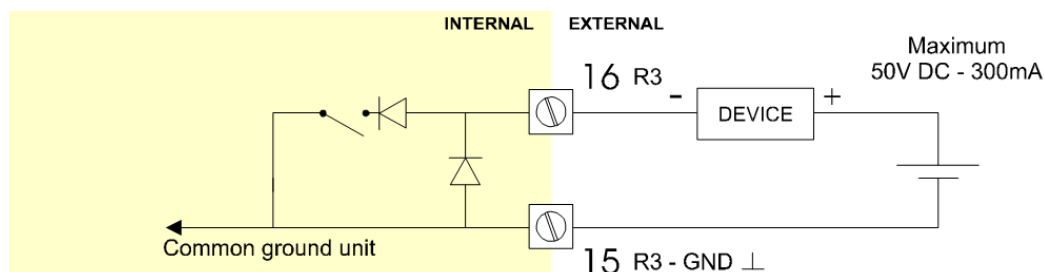

**Fig. 25: Terminal connections - Pulse output (typical)**

**Terminal 26-31: type CB / CH / CI / CT - communication RS232 / RS485 / TTL (option)**

For connections, refer to figure: Overview of terminal connectors - Standard configuration and options

Full serial communications and computer control in accordance with RS232 (length of cable max. 15 meters) or RS485 (length of cable max. 1200 meters) is possible.

When using the RS232 communication option, terminal 27 is used for supplying the interface.

Please connect the DTR (or the RTS) signal of the interface to this terminal and set it active (+12V).

If no active signal is available it is possible to connect a separate supply between terminals 26 and 27 with a voltage between 8V and 24V.

**Terminal 00 - 01: type ZB backlight (option):**

- type PD, PF or PM, the backlight supply is integrated.
- type PX, use the terminals 00 and 01 to supply the backlight.

The backlight intensity is set in the setup menu: Display.

## 5. INTRINSICALLY SAFE APPLICATIONS



- For the combined connection of the different supply, input and output circuits, the instructions in this manual must be observed. From the safety point of view the circuits shall be considered to be connected to earth.
- Certificates, safety values, control drawing and declaration of compliance can be found in the document named: "Fluidwell F1...-XI - Documentation for Intrinsic safety".
- For installation under ATEX directive: this Intrinsic safe device must be installed in accordance with the latest ATEX directive and product certificate KEMA 03ATEX1074 X.
- For installation under IECEx scheme: this Intrinsic safe device must be installed in accordance the product certificate IECEx DEK 11.0042X.
- Exchange of Intrinsic safe battery FWLiBAT-0xx with certificate number KEMA 03ATEX1071 U or IECEx KEM 08.0005U is allowed in Hazardous Area. Read chapter 6 for battery replacement instructions.
- When the enclosure of the F113-P is made of aluminum alloy, when used in a potentially explosive atmosphere requiring apparatus of EPL Ga, the indicator shall be installed so, that even in the event of rare incidents, an ignition source due to impact or friction sparks between the enclosure and iron/steel is excluded.
- When two or more active Intrinsic safe circuits are connected to the indicator, in order to prevent voltage and/or current addition, applicable to the external circuits, precautions must be taken to separate the Intrinsic safe circuits in accordance with EN 60079-11.
- To maintain the degree of protection of at least IP65 in accordance with IEC 60529, suitable cable entries and blanking elements must be used and correctly installed.
- For enclosures and windows with a high surface resistance, potential charging hazard exists. Do not rub these surfaces of the indicator. Clean window and enclosure only with a lint-free cleaning cloth made damp with a mild soap solution.
- Chapter 4 shows general information regarding the electrical installation of your indicator. This chapter gives additional specific information regarding Intrinsic safe installation and overrules the information given in chapter 4.



Caution !

- Mounting, electrical installation, start-up and maintenance of this device may only be carried out by trained persons authorized by the operator of the facility. Persons must read and understand this manual before carrying out its instructions.
- This device may only be operated by persons who are authorized and trained by the operator of the facility. All instructions in this manual are to be observed.
- Make sure, the measuring system is correctly wired up according to the wiring diagrams. Protection against accidental contact is no longer assured when the housing cover is removed or the panel cabinet has been opened (danger from electrical shock). The housing may only be opened by trained persons authorized by the operator of the facility.
- Take careful notice of the "Safety rules, instructions and precautionary measures" in the front of this manual.



Note !

- Special conditions for safe use mentioned in both the certificate and the installation instructions must be observed for the connection of power to both input and / or output circuits.
- When installing this device in hazardous areas, the wiring and installation must comply with the appropriate installation standards for your industry.
- Study the following pages with wiring diagrams per classification.



**Serial number and year of production**

This information can be looked-up in the setup menu: Others.

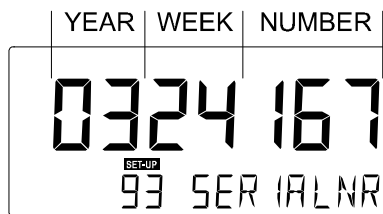

Fig. 26: Example serial number (typical)

**Label information pulse input type – F1xx-...-XI (inside and outside the enclosure)**

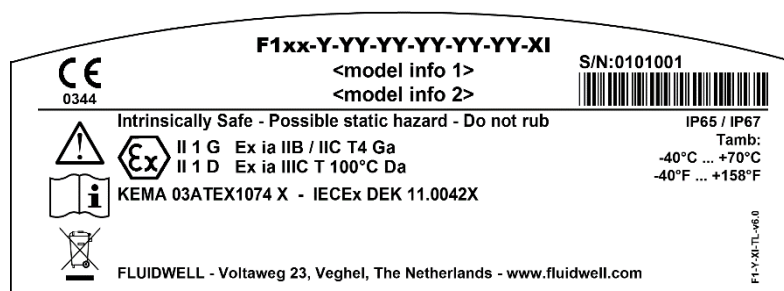

Fig. 27: Label information - Intrinsic safe application (typical)

5.1. TERMINAL CONNECTORS INTRINSIC SAFE APPLICATIONS



Note !

The unit is classified as group IIB/IIIC by default

Classification of the unit as group IIC is only possible under the following conditions:

The indicator is either supplied by

- the internal supply (type PC);
- the external supply connected to terminals 0 and 1 (type PD);
- the circuit supply connected to terminals 7 and 8 (type AP);
- The maximum values for any of those circuits are those as defined for group IIB/IIIC;
- No other active external Intrinsic safe circuits may be connected to the indicator, with exception of circuits connected to terminals 3 and 4 and/or terminals 5 and 6; the maximum values for any of those circuits are those as defined for group IIB/IIIC.

**Terminal connectors F113-P-...-XI:**

For intrinsically safe applications, consult the safety values in the certificate.

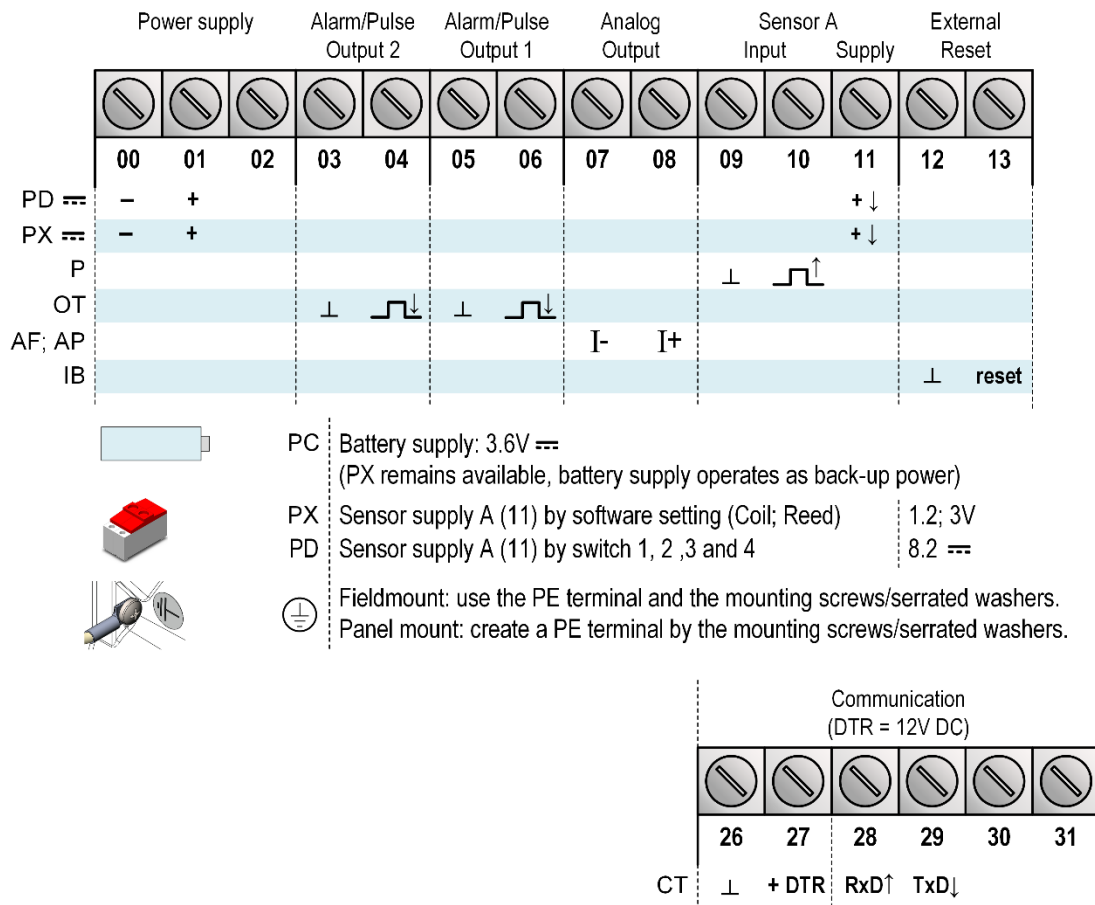

FW-F113-000002-001-EN

**Fig. 28: Overview terminal connectors XI – Intrinsic safe applications**

**Explanation Intrinsically Safe options:**

**Type AF - Intrinsically Safe floating 4-20mA analog output:**

A floating 4-20mA signal proportional to the flow rate is available with this option. When the output is disabled, a 3.5mA signal will be generated. Max. driving capacity 1000 Ohm @ 30V DC.

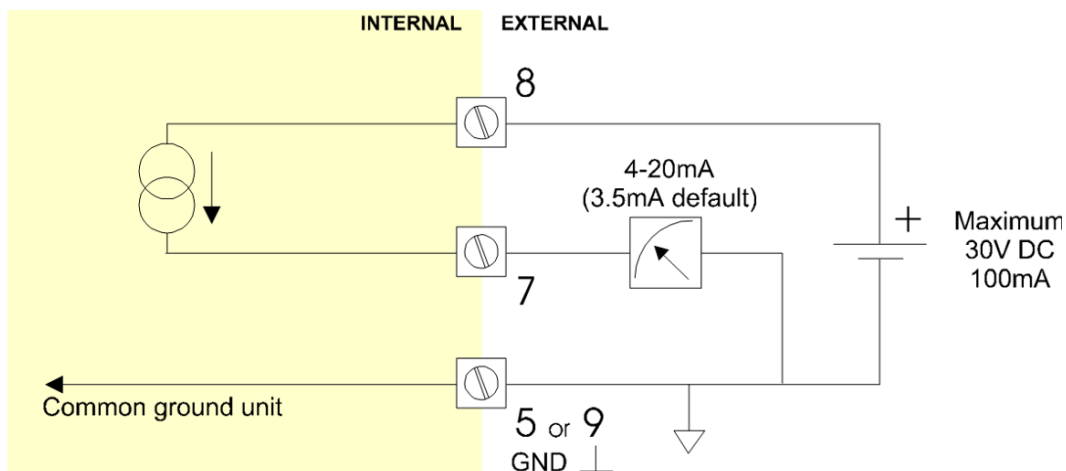

**Fig. 29: Terminal connections - Intrinsic safe floating 4-20mA analog output (typical)**

**For type PD-XI:** It is possible to supply the sensor with different voltages. You can set the voltage with the switches. Internal power is only applicable for low power sensors (Coil, Reed). The sensor supply is set by the firmware: 1.2V DC or 3V DC. External power is only available when the main external power supply is connected. The sensor supply voltage is fixed: 8.2V DC.

**Set the sensor supply**

1. Make the F113-P safe. If applicable, mind the battery power.
2. Open the F113-P and carefully remove the cable-connectors and the protective cover.
3. Find and set the switches and select the  $V_{out}$  as required.
4. Close the protective cover and install the cable connectors.
5. Close the F113-P.



**Risk of electrocution - High voltage!**

Make sure, all the leads to the terminals are disconnected from the F113-P and NEVER connect the mains power supply to the unit when the protection cover has been removed!

Type PD-XI	Power supply in: 16-30V DC / max. 1W			
	Sensor		Sensor supply out	
<p>FW-PD-000002-001-EN Switch location (typical)</p>	A			
	1	2		
	off	-		Coil 1.2V DC; <1mA Reed 3V DC; <1mA
on	-		8.2V DC; 7mA (max)	

**Fig. 30: Switch position voltage selection type PD-XI**

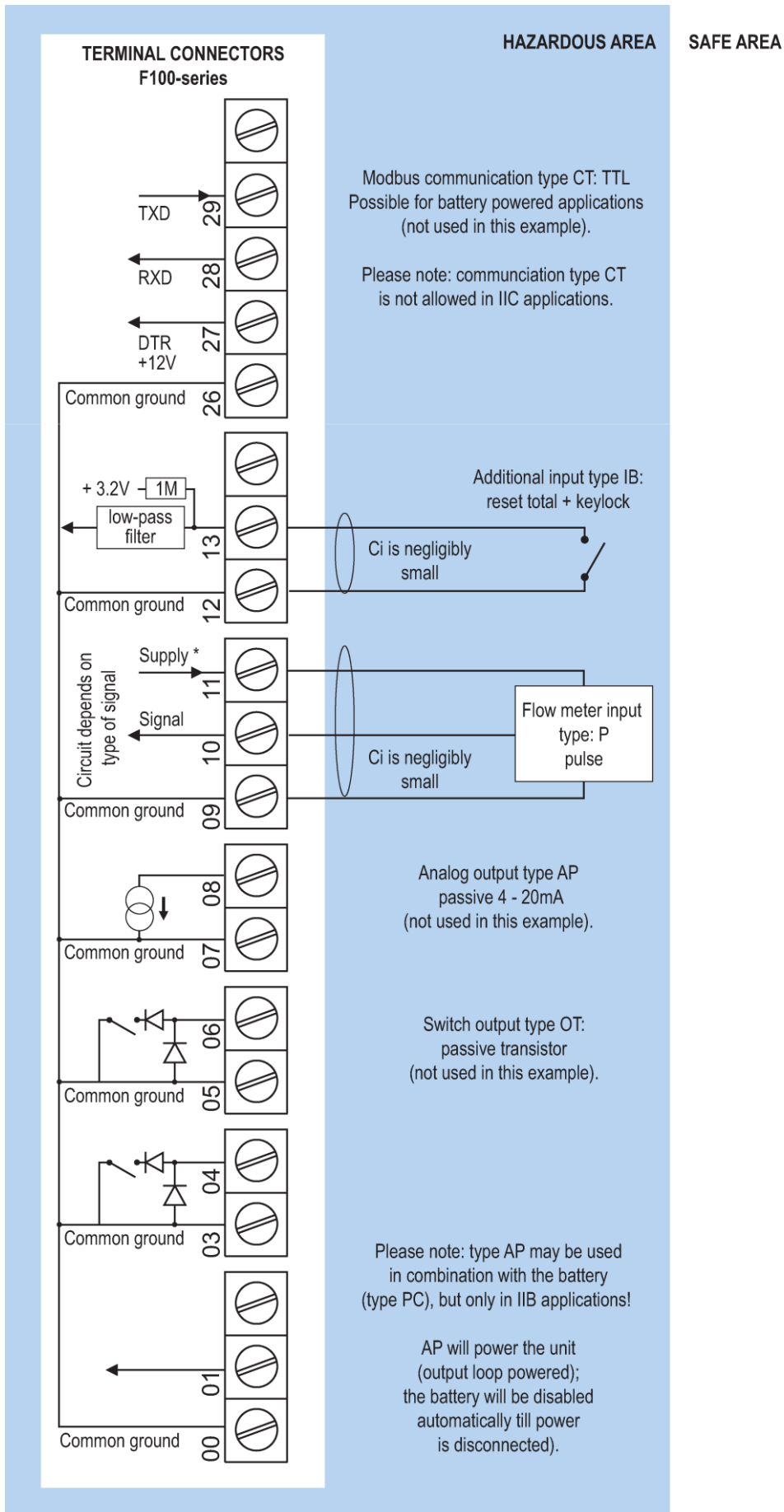

\* Note sensor supply voltage: 1.2V DC for coil sensors or 3.2V DC for other pulse sensors.

**Fig. 31: F113-P-(AP)-(CT)-IB-(OT)-PC-XI - Battery powered - IIB/IIC – IIC**

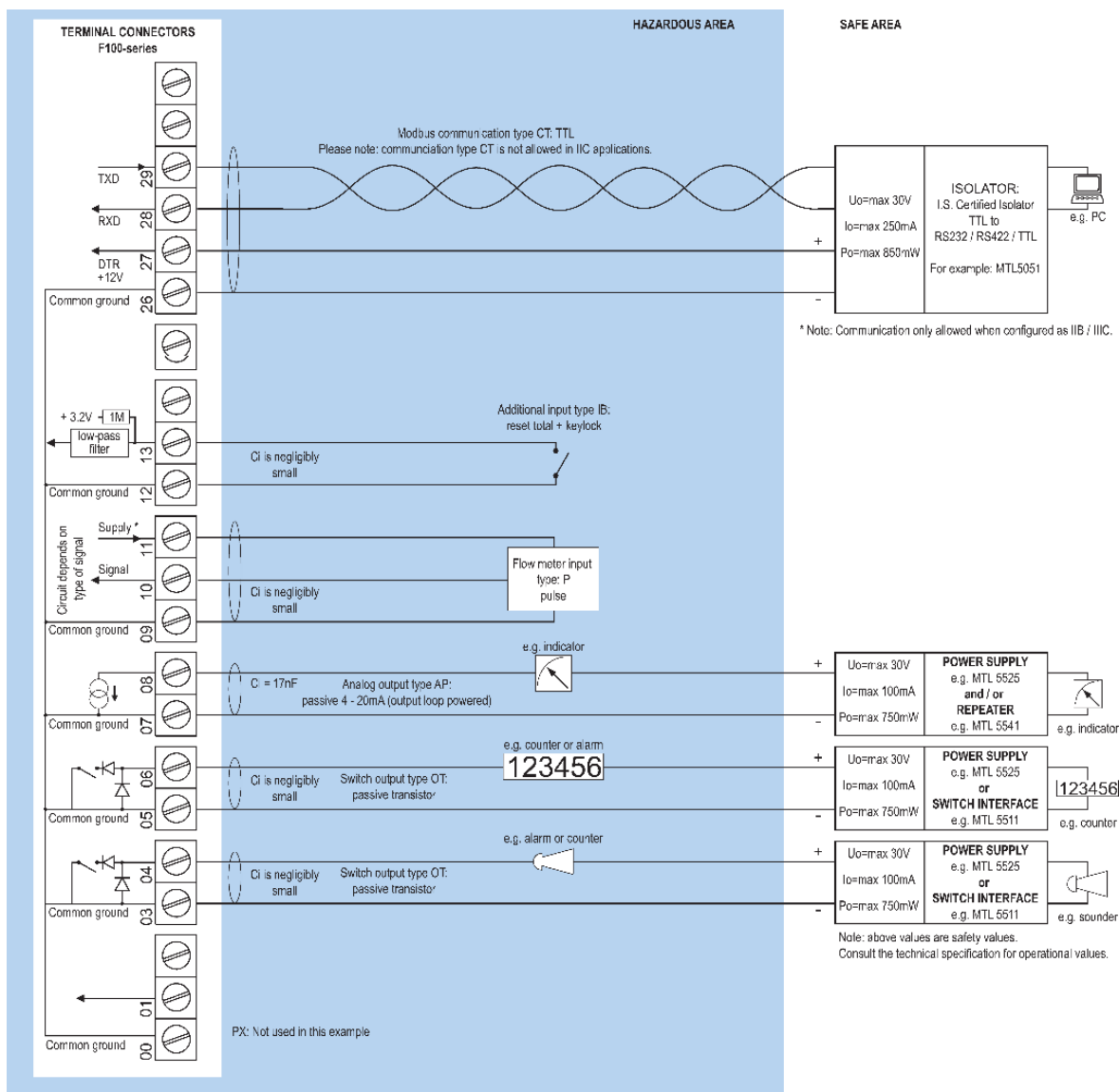

\* Note sensor supply voltage: 1.2V DC for coil sensors or 3.2V DC for other pulse sensors.

Fig. 32: F113-P-AP-(CT)-IB-OT-(PX)-XI - Output loop powered - IIB/IIC - IIC

### 5.3 BATTERY REPLACEMENT INSTRUCTIONS

#### 5.3.1. SAFETY INSTRUCTIONS



- Handle the battery with care. A mistreated battery can become unsafe. Unsafe batteries can cause (serious) injury to persons.
- Only use batteries which are certified for use in hazardous areas. The use of standard batteries in hazardous area's is not safe and prohibited. Batteries that are regarded as unsafe can cause (serious) injury to persons and damage to the property.
- Mounting, electrical installation, start-up and maintenance of this device may only be carried out by trained persons authorized by the operator of the facility. Persons must read and understand this manual before carrying out its instructions.
- Only use batteries which are certified for use in hazardous areas. The use of standard batteries in hazardous area's is not safe and prohibited. Batteries that are regarded as unsafe can cause (serious) injury to persons and damage to the property.
- For use in hazardous areas we advise to apply FW-LiBAT batteries only.



Caution !

#### 5.3.2. REPLACE THE BATTERY (HAZARDOUS AREA)

The batteries are used to store electrical energy. The battery is a high power battery which must be treated carefully. When the battery is mistreated or damaged, there is a risk of a fire, an explosion and serious burns.

1. Mind that you cannot switch off a battery.
2. Make sure, it is safe to work on the battery system.
3. Handle the battery with the utmost care to prevent a short circuit and damage.
4. Do not recharge, crush, disassemble, incinerate, heat above its rated temperature or expose the contents to water.
5. Dispose of the battery in accordance with the (inter)national, the manufacturer's and the plant owner's standards and regulations.
6. Read and understand the instructions.
7. Get approval from the safety officer to do the work.
8. Lock-out/Tag-out the unit and related system.
9. Make sure, it is safe to do the work.

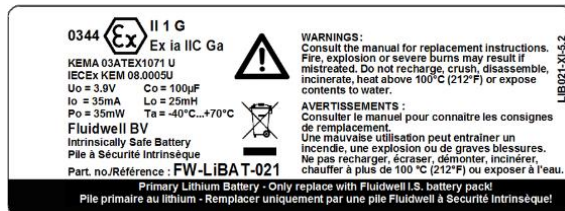

#### REMOVE THE BATTERY

1. If necessary, clean the housing with an anti-static cloth made damp with a mild soap solution.
2. Let the enclosure dry onto the air.
3. Carefully, open the enclosure.
4. Keep the removed parts in a clean location.
5. Get access to the battery.
6. Find the battery connector and disconnect the battery from the unit.
7. Remove and keep the battery from the unit.
8. Install an insulation tape over the battery connector to prevent a short circuit.

#### INSTALL THE BATTERY

1. Make sure, the new battery is certified for use in the unit.
2. Work as clean as possible, to prevent contamination to enter the unit.
3. Carefully, install the battery.
4. Make sure, the battery is correctly locked into the battery holder.
5. Install the battery connector.
6. Carefully assemble the unit and close the enclosure.
7. With the enclosure carefully closed, do a test of the unit.
8. If necessary, get access to the setup menu and make any adjustments to obtain the correct settings.

#### 5.3.3. DISPOSAL OF BATTERIES



- Batteries pose an environmental hazard.
- Do not dispose of as general waste or incinerate.
- Return used batteries to a recycling point.

## 6. MAINTENANCE

### 6.1. GENERAL DIRECTIONS



Caution !

- Mounting, electrical installation, start-up and maintenance of this device may only be carried out by trained persons authorized by the operator of the facility. Persons must read and understand this manual before carrying out its instructions.
- This device may only be operated by persons who are authorized and trained by the operator of the facility. All instructions in this manual are to be observed.
- Make sure, the measuring system is correctly wired up according to the wiring diagrams. Protection against accidental contact is no longer assured when the housing cover is removed or the panel cabinet has been opened (danger from electrical shock). The housing may only be opened by trained persons authorized by the operator of the facility.
- Take careful notice of the "Safety rules, instructions and precautionary measures" in the front of this manual.

The F113-P does not require special maintenance unless it is used in low-temperature applications or surroundings with high humidity (above 90% annual mean). It is the users responsibility to take all precautions to dehumidify the internal atmosphere of the F113-P in such a way that no condensation will occur, e.g. to put a dose of desiccant (drying agent) inside the enclosure just before closing it. Furthermore, it is required to replace the desiccant periodically as advised by its supplier.

#### Battery life-time:

It is influenced by several issues :

- Type of sensor (read chapter 3): NPN and PNP inputs consume more energy than coil inputs;
- Input frequency: the higher the frequency, the shorter the battery life-time;
- Analog output signal; be sure that an external power supply is connected or that the function is disabled if not in use; or else it will have a major influence on the battery life-time;
- Display update: fast display update uses significantly more power;
- Pulse output and communications;
- Low temperatures; the available power will be less due to battery chemistry.



Note !

*It is strongly advised to disable the unused functions.*

#### Check periodically:

- The condition of the enclosure, cable glands and front panel.
- The input/output wiring for reliability and aging symptoms.
- The process accuracy. As a result of wear and tear, re-calibration of the flowmeter might be necessary. Do not forget to re-enter any subsequent K-Factor alterations.
- The indication for low-battery.
- Clean window and enclosure only with a lint-free cleaning cloth made damp with a mild soap solution.. Do not use any aggressive solvents as these might damage the coating.

### 6.2. REPAIR

This product cannot be repaired by the user and must be replaced with an equivalent certified product. Repairs should only be carried out by the manufacturer or his authorized agent.

### 6.3. REPAIR POLICY

If you have any problem with your Fluidwell product and you wish to repair it, please follow the procedure below:





- Obtain a Return Material Authorization (RMA) from your supplier or distributor Together with the RMA, you need to complete a repair form to submit detailed information about the problem.
- Send the product, within 30 days, to the address provided with the RMA. The physical return of your repair can only take place after the authorization of your repair application, as confirmed by the RMA number.

If the product is within the warranty period, it will be repaired or exchanged and returned within three weeks. If the product is no longer under warranty, you will receive a repair estimate.

## APPENDIX A. TECHNICAL SPECIFICATION

GENERAL	
<b>Display</b>	
Type	High intensity reflective numeric and alphanumeric LCD, UV-resistant.
Digits	Seven 17mm (0.67") and eleven 8mm (0.31"). Various symbols and measuring units.
Refresh rate	User definable: 8 times/sec - 30 secs.
Type ZB	LCD with LED backlight. Improved readability in full sunlight and darkness. Power requirements: 12-24V DC + 10% or type PD, PF, PM. Power consumption max. 1 Watt.
<b>Enclosures</b>	
General	Die-cast aluminum or GRP (Glassfibre Reinforced Polyamide) enclosure with Polycarbonate window, silicone and EPDM gaskets. UV stabilized and flame retardant material.
Control Keys	Three industrial micro-switch keys. UV-stabilized silicone keypad.
Painting	Aluminum enclosure only: UV-resistant 2-component industrial painting.
Panel-mount enclosures	Dimensions: 130 x 120 x 60mm (5.10" x 4.72" x 2.38") – LxHxD.
Classification	IP65 / TYPE 4(X)
Panel cut-out	115 x 98mm (4.53" x 3.86") LxH.
Type HC	GRP panel-mount enclosure
Type HB	Aluminum panel-mount enclosure
Field/wall-mount enclosures	Dimensions: 130 x 120 x 75mm (5.10" x 4.72" x 2.95") – LxHxD.
Classification	IP67 / TYPE 4(X)
Aluminum enclosures	
Typ HA	Drilling: 2x PG9 – 1x M20.
Typ HL	Drilling: 2x ½"NPT
Typ HM	Drilling: 2x M16 – 1x M20.
Typ HN	Drilling: 1x M20.
Typ HO	Drilling: 2x M20.
Typ HP	Drilling: 6x M12.
Typ HT	Drilling: 1x ½"NPT.
Typ HU	Drilling: 3x ½"NPT.
Typ HZ	No drilling.
GRP enclosures	
Type HD	No drilling.
Type HE	Drilling: 2x 16mm (0.63") – 1x 20mm (0.78").
Type HF	Drilling: 1x 22mm (0.87").
Type HG	Drilling: 2x 20mm (0.78").
Type HH	Drilling: 6x 12mm (0.47").
<b>Operating temperature</b>	
Operational	-40°C to +80°C (-40°F to +176°F)
Intrinsically Safe	-40°C to +70°C (-40°F to +158°F)
Relative humidity	90%, no condensation allowed.
<b>Power supply</b>	
Type AP	8-30V DC; Power consumption max. 0.5 Watt.
Type PB	Lithium battery - life-time depends upon settings - up to 5 years.
Type PC	Intrinsically safe lithium battery - life-time depends upon settings - up to 5 years.
Type PD	8-24V AC / 8-30V DC; Power consumption max. 5 Watt.
Type PD-ZB	10-24V AC / 12-30V DC; Power consumption max. 5 Watt.
Type PD-XI	16-30V DC; Power consumption max. 1 Watt.
Type PF	15-24V AC / 20-30V DC; Power consumption max. 15 Watt.
Type PM	115-230V AC; Power consumption max. 15 Watt.
Type PX	8-30V DC; Power consumption max. 0.75 Watt.
Type PX-ZB	12-30V DC; Power consumption max. 1.5 Watt.
Type PX-XI	8-30V DC; Power consumption max. 0.75 Watt.
Note I.S. applications	<b>For Intrinsically safe applications, consult the safety values in the certificate.</b>
<b>Sensor excitation</b>	
Type PB / PC / PX	3V DC for low power pulse signals and 1.2V DC for coil pick-up.
Type PD	1.2; 3; 8.2; 12; 24V DC - max. 50mA@24V DC
Type PD-XI	Intrinsically safe: Pulse signals: 1.2; 3; 8.2 - max. 7mA@8.2V DC.
Type PF / PM	1.2; 3; 8.2; 12; 24V DC - max. 400mA@24V DC.
<b>Terminal connections</b>	
Type:	Removable plug-in terminal strip. Wire max. 1.5mm <sup>2</sup> and 2.5mm <sup>2</sup>



<b>Data protection</b>			
Type	EEPROM backup of all setting. Backup of running totals every minute. Data retention at least 10 years.		
Password	Configuration settings can be password protected.		
<b>Hazardous area</b>			
Intrinsically safe Type XI	<table border="1"> <tr> <td><b>ATEX approval :</b>  II 1 G Ex ia IIB/IIC T4 Ga II 1 D Ex ia IIIC T100°C Da</td> <td><b>IECEX approval :</b> Ex ia IIB/IIC T4 Ga Ex ia IIIC T100°C Da</td> </tr> </table>	<b>ATEX approval :</b>  II 1 G Ex ia IIB/IIC T4 Ga II 1 D Ex ia IIIC T100°C Da	<b>IECEX approval :</b> Ex ia IIB/IIC T4 Ga Ex ia IIIC T100°C Da
<b>ATEX approval :</b>  II 1 G Ex ia IIB/IIC T4 Ga II 1 D Ex ia IIIC T100°C Da	<b>IECEX approval :</b> Ex ia IIB/IIC T4 Ga Ex ia IIIC T100°C Da		
Explosion proof Type XD/XF	ATEX approval ref:  II 2 EEx d IIB T5. Weight appr. 15kg. Dimensions of enclosure: 350 x 250 x 200mm (13.7" x 9.9" x 7.9") LxHxD.		
<b>Directives and Standards</b>			
EMC	EN 61326-1; FCC 47 CFR part 15		
LVD	EN/IEC 61010-1		
ATEX / IECEx	EN/IEC 60079-0; EN/IEC 60079-11		
RoHS	EN 50581		
IP & NEMA	EN 60529; NEMA 250		
<b>INPUTS</b>			
<b>Flowmeter</b>			
Type P	nnp; npn-lp; reed; reed-lp; pnp; pnp-lp; namur; coil-hi; coil-lo; 8-1 DC; 12 DC; 24 DC		
Frequency	Minimum 0 Hz - maximum 7 kHz for total and flow rate. Maximum frequency depends on signal type and internal low-pass filter. E.g. Reed switch with low-pass filter: max. frequency 120 Hz.		
K-Factor	0.000010 - 9999999 with variable decimal position.		
Low-pass filter	nnp-lp; reed-lp; pnp-lp		
<b>Reset</b>			
Type IB	Make contact - external reset totalizer. Additional functionality to lock the RESET button of the keyboard (as long as this contact is being made).		
Duration	Minimum 100mSec. to reset Total.		
<b>OUTPUTS</b>			
<b>Analog output</b>			
Function	transmitting flow rate.		
Accuracy	10 bit. Error < 0.05% - update 10 times a second. Software function to calibrate the 4.00mA and 20.00mA levels precisely within set-up.		
Load	max. 1 kOhm		
Type AA	Active 4-20mA output (requires type OA + PD, PF or PM).		
Type AB	Active 0-20mA output (requires type OA + PD, PF or PM).		
Type AF	Passive floating 4-20mA output for Intrinsic safe applications (requires type PC or PD).		
Type AI	Passive galvanic isolated output (requires type PB, PD, PF, PL or PM).		
Type AP	Passive 4-20mA output - output loop powered		
Type AU	Active 0-10V output (requires type OA + PD, PF or PM).		
<b>Switch output(s)</b>			
Function	User defined: flow rate alarm or pulse output.		
Alarm output	lo-lo; lo; hi; hi-hi flow rate alarm		
Pulse output	Max. frequency 500Hz. Pulse length user definable between 0.001 up to 9.999 seconds.		
Type OA	Three active 24V DC output; max. 50mA per output (requires type PD, PF or PM).		
Type OR	Two electro-mechanical relay outputs; max. switch power 230V AC - 0.5A and one OT or OA output (requires type PF or PM).		
Type OS	Four electro-mechanical relay outputs; max. switch power 230V AC - 0.5A (requires type AP, OR and PD).		
Type OT	Three passive transistor outputs - not isolated. Load: max. 50V DC - 300mA		
<b>Communication option</b>			
Protocol	bus-rtu; bus-asc		
Speed	1200; 2400; 4800; 9600		
Address	1 - 247		
Type CB	RS232		
Type CH	RS485 2-wire		
Type CI	RS485 4-wire		
Type CT	TTL Intrinsically Safe communication.		
Type CX	no communication.		

<b>OPERATIONAL</b>	
<b>Operator functions</b>	
Displayed functions	<ul style="list-style-type: none"> <li>total and/or flow rate.</li> <li>total and accumulated total.</li> <li>total can be reset to zero by pressing the CLEAR-key twice.</li> <li>alarm values for lo-lo; lo; hi; hi-hi flow rate.</li> <li>alarm values can be entered (this function can be disabled).</li> </ul>
<b>Total</b>	
Digits	7 digits.
Units	L; m <sup>3</sup> ; GAL; USGAL; kg; lb; bbl; no unit.
Decimals	0000000; 111111.1; 22222.22; 3333.333
Note	total can be reset to zero.
<b>Accumulated total</b>	
Digits	11 digits.
Units / decimals	according to selection for total.
<b>Flow rate</b>	
Digits	7 digits.
Units	L; m <sup>3</sup> ; mg; g; kg; ton; GAL; bbl; lb; cf; rev; - - - (no unit); scf; N m <sup>3</sup> ; NI; P; mL
Decimals	0000000; 111111.1; 22222.22; 3333.333
Time units	/sec; /min; /hour; /day
<b>Alarm values</b>	
Digits	7 digits.
Units	According to selection for flow rate.
Decimals	According to selection for flow rate.
Time units	According to selection for flow rate.
Type of alarm	lo-lo; lo; hi; hi-hi flow rate alarm. Includes delay time alarm and configurable alarm outputs.

## APPENDIX B. PROBLEM SOLVING

In this appendix, several problems are included that can occur when the F113-P is going to be installed or while it is in operation.

### Flowmeter does not generate pulses:

Check:

- Signal selection;
- Pulse amplitude;
- Flowmeter, wiring and connection of terminal connectors;
- Power supply of flowmeter.

### Flowmeter generates "too many pulses":

Check:

- Settings for total and Flow rate;
- Type of signal selected with actual signal generated;
- Sensitivity of coil input;
- Proper grounding of the F113-P;
- Use screened wire for flowmeter signals and connect screen to terminal 9. (unless connected at sensor).

### Analog output does not function properly:

Check:

- is the analog output enabled?
- are the flow-levels programmed correctly?
- connection of the external power-supply according to the specification.

### Pulse output does not function:

Check:

- amount: pulse per "x" quantity; is the value programmed reasonable and will the maximum output be under 20Hz?
- width; is the external device able to recognize the selected pulse width and frequency?

### Flow rate displays "0 / zero" while there is flow (total is counting):

Check:

- are the K-Factor and time unit correct?
- The unit has to count the number of pulses according to setup 26 within the time according to setup 27. Make sure, setup 27 is set to 10.0 seconds for example : the result is that the unit has at least 10 seconds time to measure the number of pulses according to setup 26.

### The password is unknown:

If the password is not 1234, there is only one possibility left: call your supplier.

## ALARM

When the alarm flag starts to blink an internal alarm condition has occurred. Press the "select button" several times to display the error code. When multiple errors arise at the same time, their error codes are added and their sum is shown. The digital [d] codes are:

### Not recoverable by the end user:

- [d] 0 = no error;
- [d] 1 = display error;
- [d] 2 = data-storage error;
- [d] 3 = error 1 + error 2 simultaneously;
- [d] 4 = initialization error.

For a not recoverable error, keep the error code at hand and contact your supplier.

## APPENDIX C. COMMUNICATION VARIABLES

### General

The product is fitted with the Modbus communication protocol and can be equipped with various physical interfaces like RS485 and RS232 (please see device datasheet for available options). The tables below show the various variables that can be accessed through the communication. Currently, the function codes supported are:

- function code 3 “Read Holding Registers” (4x references);
- function code 16 “Preset Multiple Registers” (4x references).

The table below shows the Modbus PDU addresses in a decimal format, followed by its hexadecimal representation (0x0000). When the PLC address range is required (4x references are typically used by PLCs), please add a value of 40001 to the Modbus PDU address. E.g. reading the serial number of the product with PLC-based addressing means: 165 + 40001 = register 40166.

**The variables that consist of a multiple register must always read/write in 1 single action!**

Refer to the illustration:

For this example it is assumed that the variable accumulated total has 3 registers (words) with address 566, 567 and 568. When a transmission is done, register 566, which acts as the MSW, arrives first with bit 15 which is the MSB of the lowest addressed word, but is also the MSB (bit 47) of the complete variable that represents the Accumulated total.

Although most Modbus Masters will support variables that span 2 registers, variables spanning more registers sometimes require you to manually calculate the resulting value.

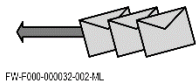
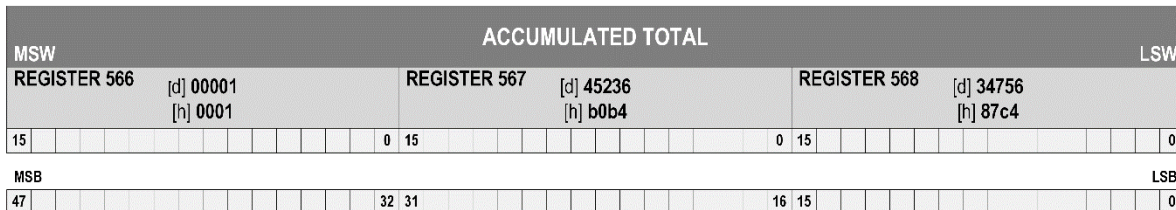

$$\text{ACCUMULATED TOTAL: } [\text{register } 566 * 4294967296] + [\text{register } 567 * 65536] + [\text{register } 568 * 1] =$$

$$[\text{d}] \text{ ACCUMULATED TOTAL: } [00001 * 4294967296] + [45236 * 65536] + [34756 * 1] = 7259588540$$

$$[\text{h}] \text{ ACCUMULATED TOTAL: } 0x[0001] [b0b4] [87c4] = 1B0B487BC$$

For additional information regarding using your Modbus device, please read our 'General Modbus Communication Protocol' and 'Modbus troubleshooting guide' that are available through our website or your distributor.

### Runtime variables

PDU ADDRESS	REGISTER	VARIABLE	NO. REGISTERS	R/W	TYPE	VALUE / REMARKS
[d] 572d [h] 0x23C	40573	flow rate	2	R	uint32	0...9999999, Representation: unit, time, decimals depending on variables 48, 49, 50
[d] 566d [h] 0x236	40567	Total	3	R*	uint48	0...9999999999, Representation: unit, decimals depending on variables 32, 33
[d] 560d [h] 0x230	40561	accumulated total	3	R	uint48	0...99999999999999, Representation: unit, decimals depending on variables 32, 33
[d] 516 [h] 0x204	40517	error status (bitfield)	1	R	uint16	[d] 0 = no error [d] 1 = display error [d] 2 = data-storage error [d] 3 = error 1 + error 2 simultaneously [d] 4 =: initialization error

**Reading flow rate, total or accumulated total:** The returned values are given including the decimals and represent the actual value. The given value may differ from the value that is displayed on the display – this is due to the fact that the display is limited in the number of digits and may have a slower update rate set.

For example when two decimals are selected for total and total has a value of 123456,78 the display will show 23456,78 while communication will read a “total” of 12345678 (note that the decimals should be adapted according the setting in “total decimals” which is in this case 2).

\* **Clearing total:** It is possible to clear the total counter by means of writing a value of 0 to all the 3 registers of total/flow rate in a single write action. Writing any other value will result in the reply of an error message because the registers of total/flow rate are during operation read-only.

## Setup variables

PDU ADDRESS	REGISTER	VARIABLE TOTAL	NO. REGISTERS	R/W	TYPE	VALUE / REMARKS
[d] 32 [h] 0x020	40033	unit	1	r/w	uint16	0=none 3=kg 6= USGAL 1=L 4= lb 7=bbbl 2= m <sup>3</sup> 5=GAL
[d] 33 [h] 0x021	40034	decimals	1	r/w	uint16	0...3
[d] 34 [h] 0x022	40035	K-factor	2	r/w	uint32	1...9999999, Representation: 0.000010...9999999 depending on variable 37: K-factor decimals.
[d] 37 [h] 0x025	40038	K-factor decimals	1	r/w	uint16	0...6
PDU ADDRESS	REGISTER	VARIABLE FLOW RATE	NO. REGISTERS	R/W	TYPE	VALUE / REMARKS
[d] 48 [h] 0x030	40049	unit	1	r/w	uint16	0=mL 4=g 8=bbbl 12=none 1=L 5=kg 9=lb 13=scf 2= m <sup>3</sup> 6=ton 10=cf 14=NM <sup>3</sup> 3=mg 7=GAL 11=rev 15=NL 16=p
[d] 49 [h] 0x031	40050	time unit	1	r/w	uint16	0=sec 2=hour 3=day 1=min
[d] 50 [h] 0x032	40051	decimals	1	r/w	uint16	0...3
[d] 51 [h] 0x033	40052	K-Factor	2	r/w	uint32	1...9999999 Representation: 0.000010...9999999 depending on variable 54: K-factor decimals.
[d] 54 [h] 0x036	40055	K-Factor decimals	1	r/w	uint16	0...6
[d] 55 [h] 0x037	40056	number of pulses	1	r/w	uint16	1...255 pulses
[d] 56 [h] 0x038	40057	cut-off time	1	r/w	uint16	1...9999 Representation: 0.1 – 999.9 sec
PDU ADDRESS	REGISTER	VARIABLE ALARM	NO. REGISTERS	R/W	TYPE	VALUE / REMARKS
[d] 70 [h] 0x046	40071	flow zero	1	r/w	uint16	0=ignore 1=default 2=no relay
[d] 234 [h] 0x0EA	40235	alarm value low-low	2	r/w	uint32	0...9999999
[d] 240 [h] 0x0F0	40241	alarm value low	2	r/w	uint32	0...9999999
[d] 243 [h] 0x0F3	40244	alarm value high	2	r/w	uint32	0...9999999
[d] 237 [h] 0x0ED	40238	alarm value high-high	2	r/w	uint32	0...9999999
[d] 205 [h] 0x0CD	40206	delay time value low-low	1	r/w	uint16	0...999.9
[d] 246 [h] 0x0F6	40247	delay time value low	1	r/w	uint16	0...999.9
[d] 248 [h] 0x0F8	40249	delay time value high	1	r/w	uint16	0...999.9
[d] 222 [h] 0x0DE	40223	delay time value high-high	1	r/w	uint16	0...999.9
PDU ADDRESS	REGISTER	VARIABLE DISPLAY	NO. REGISTERS	R/W	TYPE	VALUE / REMARKS
[d] 64 [h] 0x040	40065	display function	1	r/w	uint16	0=total 1=flow rate
[d] 68 [h] 0x044	40069	Alarm set	1	r/w	uint16	0=operate 1=setup 2=hidden
[d] 67 [h] 0x043	40068	backlight brightness	1	r/w	uint16	0=off 2=40% 4=80% 1=20% 3=60% 5=100%
[d] 110 [h] 0x06E	40111	Backlight alarm	1	r/w	uint16	0=off 1=on 2=flash

PDU ADDRESS	REGISTER	VARIABLE POWER MANAGEMENT	NO. REGISTERS	R/W	TYPE	VALUE / REMARKS
[d] 80 [h] 0x050	40081	LCD update time	1	r/w	uint16	0=fast 2=3sec 4=30sec 1=1sec 3=15sec 5=off
[d] 81 [h] 0x051	40082	power mode	1	r/w	uint16	0=operational 1=shelf
PDU ADDRESS	REGISTER	VARIABLE FLOWMETER	NO. REGISTERS	R/W	TYPE	VALUE / REMARKS
[d] 96 [h] 0x060	40097	flowmeter signal	1	r/w	uint16	0=NPN 4=PNP 8= coil lo 1=NPN LP 5=PNP LP 9=act 8.1V 2=Reed 6=NAMUR 10= act 12 V 3=Reed LP 7=coil hi 11=act 24V
PDU ADDRESS	REGISTER	VARIABLE ANALOG	NO. REGISTERS	R/W	TYPE	VALUE / REMARKS
[d] 112 [h] 0x070	40113	analog output	1	r/w	uint16	0=disable 1=enable
[d] 113 [h] 0x071	40114	minimum rate	2	r/w	uint32	0...9999999, Representation: unit, time, decimals depending on variables 48, 49, 50
[d] 116 [h] 0x074	40117	maximum rate	2	r/w	uint32	0...9999999,Representation: unit, time, decimals depending on variables 48, 49, 50
[d] 119 [h] 0x077	40120	cut off percentage	1	r/w	uint16	0...99 Representation: 0.0 – 9.9%
[d] 120 [h] 0x078	40121	tune minimum rate	1	r/w	uint16	0...9999
[d] 122 [h] 0x07A	40123	tune maximum rate	1	r/w	uint16	0...9999
[d] 127 [h] 0x07F	40128	filter	1	r/w	uint16	1...99
PDU ADDRESS	REGISTER	VARIABLE RELAYS	NO. REGISTERS	R/W	TYPE	VALUE / REMARKS
[d] 135 [h] 0x087	40136	relay 1	1	r/w	uint16	0=off 2=LO 4=HH 6=pulse 1=LL 3=HI 5=all
[d] 136 [h] 0x088	40137	relay 2	1	r/w	uint16	0=off 2=LO 4=HH 6=pulse 1=LL 3=HI 5=all
[d] 137 [h] 0x089	40138	relay 3	1	r/w	uint16	0=off 2=LO 4=HH 6=pulse 1=LL 3=HI 5=all
[d] 138 [h] 0x08A	40139	relay 4 (optional)	1	r/w	uint16	0=off 2=LO 4=HH 6=pulse 1=LL 3=HI 5=all
[d] 128 [h] 0x080	40129	pulse width	1	r/w	uint16	0.000 – 9.999 seconds (0=off)
[d] 133 [h] 0x085	40134	decimals	1	r/w	uint16	0 ... 3
[d] 130 [h] 0x082	40131	amount	2	r/w	uint32	0.001 - 9999999
PDU ADDRESS	REGISTER	VARIABLE COMMUNICATION	NO. REGISTERS	R/W	TYPE	VALUE / REMARKS
[d] 144 [h] 0x090	40145	speed (Baudrate)	1	r/w	uint16	0=1200 1=2400 2=4800 3=9600
[d] 145 [h] 0x091	40146	Modbus address	1	r/w	uint16	1...247
[d] 146 [h] 0x092	40147	Modbus mode	1	r/w	uint16	0: ASCII 1: RTU 2: OFF

PDU ADDRESS	REGISTER	VARIABLE OTHERS	NO. REGISTERS	R/W	TYPE	VALUE / REMARKS
[d] 173 [h] 0x0AD	40174	model number	1	r	uint16	0...9999
[d] 160 [h] 0x0A0	40161	model suffix	1	R	char	Representation: ASCII character
[d] 162 [h] 0x0A2	40163	firmware version	2	r	uint32	0...999999, Representation: nn:nn:nn
[d] 165 [h] 0x0A5	40166	serial number	2	r	uint32	0...9999999 Representation: nnnnnnn
[d] 168 [h] 0x0A8	40169	password	1	r	uint16	0...9999
[d] 170 [h] 0x0AA	40171	tag-nr	2	r/w	uint32	0...9999999 Representation: nnnnnnn



## APPENDIX D. DECLARATION OF CONFORMITY



*Count on us.*

# Declaration of Conformity

## Fluidwell F1-series indicators

Veghel, July 2016

We, Fluidwell BV, declare under our sole responsibility that the F1-series indicators are designed and will operate conform the following applicable European Directives and Harmonised Standards, when installed and operated according to the related manual:

<b>EMC Directive</b>		EN61000-6-2:2005; EN61000-6-3:2007; EN61326-1:2013
<b>RoHS Directive</b>		EN 50581:2012
<b>Low Voltage Directive</b>	For options –PM or –OR:	EN61010-1:2010
<b>ATEX Directive</b>	For option –XI, intrinsically safe:	EN60079-0:2012+A11; EN60079-11:2012
	Protective system:	Ⓜ II 1 G Ex ia IIB/IIC T4 Ga Ⓜ II 1 D Ex ia IIIC T100 °C Da
<b>Certification</b>	Certificates:	KEMA 03ATEX1074 X, Issue 5
	Notified body 0344:	DEKRA Certification BV, Meander 1051, 6825 MJ, Arnhem, the Netherlands.

Last two digits of the year in which the CE marking was affixed: 03.



Fluidwell BV

i. Meij, Manager Technology

Fluidwell BV are ISO9001 certified by DEKRA Certification BV, Meander 1051, 6825 MJ, Arnhem, The Netherlands.

	<b>Fluidwell bv</b> P.O. Box 6 • 5460 AA • Veghel Voltaweg 23 • 5466 AZ • Veghel The Netherlands	Telephone: +31 (0) 413 - 343 786 Telefax: +31 (0) 413 - 363 443 Email: displays@fluidwell.com Internet: www.fluidwell.com	Trade Reg. No: 17120985 VAT No: NL8085.29.699.B.01 Bank: ING-Bank SWIFT Nr / BIC: INGBNL2A	EUR account no: 66.63.96.078 IBAN: NL73 INGB 0666 3960 78 USD account no: 02.20.81.771 IBAN: NL22 INGB 0022 0817 71
---	---	--	---	--



## INDEX OF THIS MANUAL

accumulated Total .....	8	high alarm output .....	25, 31
actual settings .....	51	Installation .....	18
analog		Intrinsic safety .....	32, 34
floating output .....	35	Intrinsically Safe options .....	35
flowrate min.....	15	IP classification.....	18
intrinsically safe output .....	35	Low-battery alarm .....	8
isolated output.....	27	maintenance .....	39
tune / calibrate .....	15	model.....	17
backlight		NAMUR-signal.....	30
density.....	13	operational.....	7, 9, 10, 39
battery life time .....	39	operator level.....	7
Clear Total .....	7	pass code .....	17, 43
coil-signal .....	28	Problem solving.....	43
Coil-signal.....	28	pulse output	
communication .....	31	pulse length / period time .....	16
family-specific variables .....	44, 48	Pulse-signal NPN/PNP .....	29
Dimension enclosures .....	19	rate/Total .....	7
display		Reed-switch:.....	30
function .....	13	<i>relay output</i>	
external reset option.....	30	<i>function</i> .....	16
Flowmeter input.....	28	serial number.....	17
flowrate		tagnumber .....	17
alarm .....	8	Technical specification .....	40
<i>calculation</i> .....	13	version software .....	17

## LIST OF FIGURES IN THIS MANUAL

Fig. 1: Typical application .....	6
Fig. 2: Control Panel .....	7
Fig. 3: Process information (typical) .....	7
Fig. 4: Low-battery alarm (typical) .....	8
Fig. 5: Aluminum enclosures - Dimensions .....	19
Fig. 6: GRP enclosures - Dimensions .....	20
Fig. 7: Overview of terminal connectors - Standard configuration and options .....	24
Fig. 8: Sensor supply voltage - Switch setting .....	25
Fig. 9: Terminal connections - Active output (typical) .....	26
Fig. 10: Terminal connections - Mechanical relay output (typical) .....	26
Fig. 11: Terminal connections - Pulse output (typical) .....	26
Fig. 12: Terminal connections - 4-20mA analog output (typical) .....	27
Fig. 13: Terminal connections - Active 0-20mA analog output (typical) .....	27
Fig. 14: Terminal connections - Isolated 4-20mA analog output (typical) .....	27
Fig. 15: Terminal connections - Passive 4-20mA analog output (typical) .....	28
Fig. 16: Terminal connections - Active 0-10V analog output (typical) .....	28
Fig. 17: Terminal connections - Coil signal input (typical) .....	28
Fig. 18: Terminal connections - NPN signal input (typical) .....	29
Fig. 19: Terminal connections - PNP signal input (typical) .....	29
Fig. 20: Terminal connections - Active signal input (typical) .....	29
Fig. 21: Terminal connections - Reed-switch signal input (typical) .....	30
Fig. 22: Terminal connections - NAMUR signal input (typical) .....	30
Fig. 23: Terminal connections – External reset (typical) .....	30
Fig. 24: Terminal connections - Active output (typical) .....	31
Fig. 25: Terminal connections - Pulse output (typical) .....	31
Fig. 26: Example serial number (typical) .....	33
Fig. 27: Label information - Intrinsic safe application (typical) .....	33
Fig. 28: Overview terminal connectors XI – Intrinsic safe applications .....	34
Fig. 29: Terminal connections - Intrinsic safe floating 4-20mA analog output (typical) .....	35
Fig. 30: Switch position voltage selection type PD-XI .....	35
Fig. 31: F113-P-(AP)-(CT)-IB-(OT)-PC-XI - Battery powered - IIB/IIC – IIIC .....	36
Fig. 32: F113-P-AP-(CT)-IB-OT-(PX)-XI - Output loop powered - IIB/IIC - IIIC .....	37

LIST OF CONFIGURATION SETTINGS			
SETTING	DEFAULT	DATE	DATE
<b>1 - TOTAL</b>	Enter your settings here		
11 unit	L		
12 decimals	0000000		
13 K-factor	1		
14 decimals K-factor	0		
<b>2 - FLOW RATE</b>			
21 unit	L		
22 time	/min		
23 decimals	0000000		
24 K-factor	1		
25 decimals K-factor	0		
26 calculation	PLS 10		
27 cut-off	30.0		
<b>3 - ALARM</b>			
31 flowzero	ignore		
32 alarm ll	0		
33 alarm lo	0		
34 alarm hi	0		
35 alarm hh	0		
36 delay ll	0.0		
37 delay lo	0.0		
38 delay hi	0.0		
39 delay hh	0.0		
<b>4 - DISPLAY</b>			
41 function	total		
42 alarm set	operate		
43 light	100%		
44 bl alarm	off		
<b>5 - POWER MANAGEMENT</b>			
51 LCD-new	1 sec		
52 battery mode	operate		
<b>6 - FLOWMETER</b>			
61 signal	coil-lo		
<b>7 - ANALOG OUTPUT</b>			
71 output	disable		
72 rate-min	0		
73 rate-max	99999		
74 cut off	PERC. 0.0		
75 tune-min	160		
76 tune-max	6656		
77 filter	1		
<b>8 - PULSE OUTPUT</b>			
81 relay 1	off		
82 relay 2	off		
83 relay 3	off		
84 relay 4	off		
85 width	0.000		
86 decimals	0000000		
87 amount	1000		
<b>9 - COMMUNICATION</b>			
91 speed	9600		
92 address	1		
93 mode	BUS-RTU		
<b>A - OTHERS</b>			
A1 model	F113-P		
A2 software version			
A3 serial no.			
A4 password	0000		
A5 tag-nr	0000000		

