

**871A pH/ORP
Sensors and Accessories
Installation and Maintenance**



Contents

Figures	5
Tables	7
1. Introduction	9
Dangers, Warnings, and Cautions	9
Reference Documents	10
Theory of Operation	10
pH Measurement	10
ORP Measurement.....	11
Standard Specifications.....	12
Electrical Safety Specifications.....	13
Sensor Identification	14
Sensor/Analyzer/Transmitter Compatibility.....	14
Model Code	15
2. Installation	17
Sensor Mounting.....	17
General Installation Guidelines	17
Installation Using Sensor Threads.....	18
Flow Chamber Installation	19
Bushing Installation.....	20
Tee Installation	21
Electrode Protection Sleeve Installation	23
Submersion/Immersion Installations	23
Installation Using Ball Valves.....	24
Installing the Ball Valve Assembly Into the Process	25
Connecting the Sensor to the Insertion Shaft Assembly.....	26
Installing the Insertion Shaft into the Ball Valve	26
Removing and Replacing a Sensor	28
Electrode Cleaning System	28
Wiring	28
Connections to Analyzer or Transmitter	28
Cable Variations	30
Cable Length.....	30

3. Preventive Maintenance..... 33

- Standardization33
- Electrode Inspection33
- Cleaning Glass Electrode.....33
- Cleaning ORP Electrode33
- Cleaning Reference Junction34
- Storing a Sensor34

4. Sensor Troubleshooting..... 35

- 871A-1 and -3 Sensor (Without Preamplifier)35
- 871A-2 and A-4 Sensor (With Preamplifier)36

Index..... 39

Figures

1	Process Pressure-Temperature Limits	12
2	871A Sensor Data Label	14
3	Side of Tank/Vessel Mounting	18
4	Pipe Mounting	18
5	Flow Chamber Installation	20
6	Bushing	20
7	Typical Bushing Installation	21
8	Tee	22
9	Typical Tee Installation	22
10	Electrode Protection Sleeve	23
11	Submersion/Immersion Installation	24
12	Ball Valve Assembly	25
13	Insertion Shaft Assembly	26
14	Ball Valve Shaft Installation and Removal	27
15	Cable Lengths for 871A-1 Sensors	30
16	Cable Lengths for 871A-2 Sensor	31
17	Cable Lengths for 871A-3 Sensors	31
18	Cable Lengths for 871A-4 Sensor	31

Tables

1	Reference Documents	10
2	871A Sensor Electrical Safety Specifications	13
3	Analyzer/Transmitter Loop Approvals and Certifications.....	13
4	Sensor/Analyzer/Transmitter Compatibility.....	14
5	Flow Chamber Specifications	19
6	Bushing Specifications.....	21
7	Tee Specifications	22
8	Ball Valve Assembly Specifications.....	25
9	Analyzer and Transmitter Connections.....	29
10	Sensor (871A-1 and -3) Without Preamplifier.....	29
11	Sensor (871A-2 Series) With Preamplifier	29
12	Sensor (871A-4 Series) with Preamplifier	30
13	Process Temperature vs. Temperature Sensor Resistance.....	35

1. Introduction

The 871A-1 and -2 (standard) Sensors are designed for use with 873PH and 873DPX Analyzers. They can also be used with 875PH Analyzers and 870ITPH Transmitters.

871A-3 and -4 (intelligent) Sensors are designed for use with 875PH Intelligent Analyzers and 870ITPH Intelligent Transmitters. They provide the additional capability of on-line diagnostics to signal the user if any of several common sensor faults occur. These sensors may be mounted to the process in a number of ways. They have a 1-inch external NPT connection on both the electrode and cable end. The sensors can be inserted directly into the process line or through a variety of accessories that adapt this connection to other standard pipe sizes. In-situ mounting into weirs, flumes, ponds and tanks is achieved by coupling the 1-inch NPT connection at the cable end of the sensor to the required length of 1-inch pipe and then lowering the assembly into the process being monitored.

These sensors, with their sealed electrode design, eliminate concerns of electrode system integrity. The intelligent sensor design, when used with the intelligent analyzer or transmitter, signals the user if electrode system integrity is lost or destroyed. All sensors are factory tested to ensure proper performance upon installation.

Dangers, Warnings, and Cautions

⚠ DANGER

When performing maintenance, wear appropriate protective clothing including safety goggles. Escaping chemicals under pressure can cause severe injury including blindness.

⚠ WARNING

1. Use care when connecting and disconnecting high-pressure service connection. Use proper gloves and follow the recommended procedure to avoid severe injury to personnel or damage to equipment.
 2. When processing hazardous liquids, follow the recommended procedures. Failure to do so could result in injury to personnel and damage to equipment.
 3. Use only spare parts recommended by the company. Substitution parts could result in damage to equipment, damage to the process, and/or injury to personnel.
-

⚠ CAUTION

To prevent damage, use care when handling sensitive sensor components such as glass electrodes.

Reference Documents

Table 1. Reference Documents

Document ^(a)	Description
DP 611-141	Model ECS Electrode Cleaning System
DP 611-144	871A pH and ORP Sensors
DP 611-145	871A pH and ORP Sensor Accessories
DP 611-157	Ball Valve Assemblies Used with 871A Sensors
MI 611-125	Model ECS Electrode Cleaning System
MI 611-155	870PH pH and ORP Transmitters
MI 611-165	873PH Electrochemical Analyzers for pH or ORP Measurement
MI 611-190	873DPX Dual pH/ORP/ISE Electrochemical Analyzers
MI 611-206	Intrinsic Safety Connection Diagrams and Nonincendive Circuits
MI 611-208	Electrochemical Products Safety Information (for European installations)
MI 611-211	870ITPH Intelligent Electrochemical Transmitters
MI 611-225	875PH Intelligent Electrochemical Analyzer
TI 5-26a	DIN Platinum RTD Temperature Resistance Tables
TI 005-028	ASTM and IEC Platinum RTD Temperature Resistance Tables

(a) Documents are available at www.fielddevices.foxboro.com.

Theory of Operation

pH Measurement

pH indicates the concentration of hydrogen ions (H⁺) present in aqueous solution. Since the concentration of hydrogen ions determines the degree of acidity or alkalinity of the solution, pH is also said to be a measure of acidity or alkalinity. pH is defined as the negative logarithm of the hydrogen ion concentration:

$$\text{pH} = -\log [\text{H}^+]$$

The pH scale ranges from 0 to 14 with a pH of 7 being neutral, a pH less than 7 being acidic, and a pH greater than 7 being basic (alkaline).

Measurement of pH by the 871A Sensors is accomplished by immersing the probe, which consists of integral pH and reference electrodes, in the process solution. The pH electrode, which is sensitive to hydrogen ions in solution, develops an electrical potential proportional to pH. The reference electrode, which consists of Silver/Silver Chloride connected to the process via a Potassium Chloride salt bridge through a ceramic junction, provides a stable reference potential against which the glass electrode potential is measured. These two electrodes constitute a galvanic cell having a millivolt output proportional to the pH of the solution.

ORP Measurement

ORP is a measure of the electrical potential of a reaction known as an oxidation-reduction (redox) reaction. A redox reaction is one in which one component loses one or more electrons (oxidation) while another component gains one or more electrons (reduction). The oxidation-reduction potential is related to the ratio of oxidation activity to reduction activity. By convention, a solution that contains an excess of oxidizing agent has a positive ORP, and a solution that contains an excess of reducing agent has a negative ORP.

Measurement of ORP is accomplished by immersing the 871A Sensor, configured with a gold or platinum electrode, in a solution along with its integral silver/silver chloride reference electrode. This probe develops a millivolt output (similar to pH measurement) that is proportional to the ratio of oxidizing agent to reducing agent, or ORP.

Standard Specifications

Automatic Temperature Compensation (ATC)	100 Ω platinum RTD in -1 and -2 (standard) versions and 1000 Ω platinum RTD in -3 and -4 (intelligent) versions. Refer to TI 5-26a and TI 005-028 respectively, for resistance temperature tables.
Process Pressure-Temperature Limits	See Figure 1.
Cable Temperature Limit	85°C (185°F)
Sensor Immersion Depth	76 mm (3 in) minimum.
Process Wetted Parts Materials: Body Measuring Electrode pH ORP Reference Electrode O-Ring	PVDF (polyvinylidene fluoride). Flat Glass. Platinum or gold, as specified. Ceramic Junction. EPR (Ethylene Propylene Rubber).
Reference Electrode	Ceramic, double junction with KC1, nonflowing, gelled electrolyte (Ag, AgCl half cell).
Cable	Integral 3 m (10 ft) No. 22 AWG with stripped and tinned ends. Intelligent sensors have lugs as standard.
Sensor Mounting	1 NPT on both ends with a 1.125-inch wrench flat on body (see Figure 2).
Sensor Torque	Maximum torque specification is 31 N•m (23 lb•ft).
Measurement Range pH ORP	2 to 12 pH. (Sensor can be used with transmitters and analyzers that are ranged from 0-14 pH) ±2000 mV.
Mass	0.35 kg (0.75 lb) including cable.
Temperature and Pressure Limits	See Figure 1.
Electromagnetic Compatibility (EMC)	The 871A Sensor, when its cable is connected through rigid metal conduit as recommended to 873PH, 873APH, 873DPX (220 V ac, 240 V ac Metal Enclosures only), 875PH, or 870ITPH Analyzers/Transmitters, complies with the requirements of the European EMC Directive 89/336/EEC.

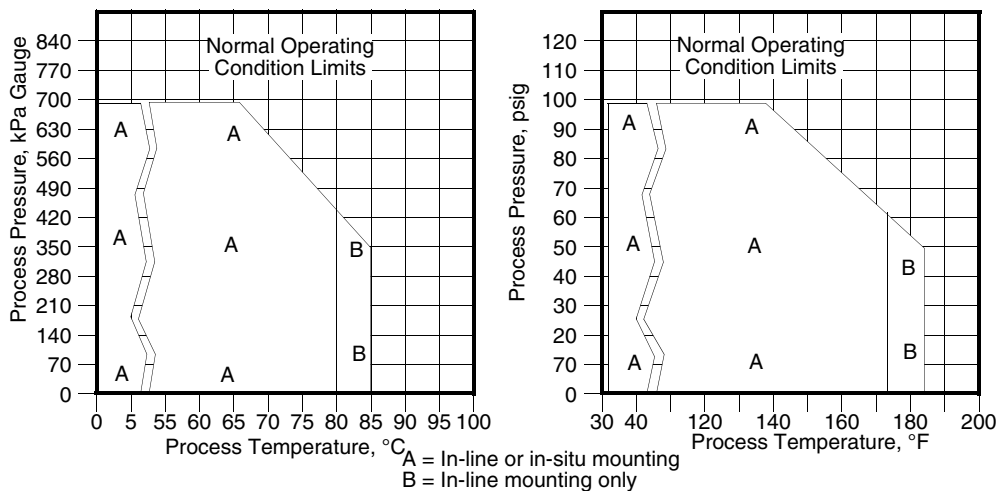

Figure 1. Process Pressure-Temperature Limits

Electrical Safety Specifications

Table 2. 871A Sensor Electrical Safety Specifications

Testing Laboratory, Type of Protection, and Area Classification	Application Conditions	Electrical Safety Design Code
ATEX Type n energy limited for II 3GD EEx nL IIC, Zone 2	Connect to instrument per MI 611-208. Temperature Class T4 - T6. T110°C - T235°C	CS-E/ANN
ATEX intrinsically safe for II 1GD EEx ia IIC, Zone 0	Connect to instrument per MI 611-208. Temperature Class T4 - T6. T110°C - T235°C	CS-E/AAA
FM intrinsically safe for Class I; Division 1, Groups A, B, C, and D; Class II, Division 1, Groups E, F, and G; Class III, Division 1.	Connect to Foxboro 870ITPH-##FAA, Foxboro 875PH-##F, or other associated apparatus with compatible entity parameters per MI 611-206. Temperature Class T4 at 85°C (185°F) maximum ambient.	CS-E/FAA
FM nonincendive Class I, Division 2, Groups A, B, C, and D; Suitable for Class II, Division 2, Groups F and G; Class III, Division 2.	Connect to Foxboro 870ITPH-##FNZ, or 875PH-##F, or other associated apparatus with compatible entity parameters per MI 611-206. Temperature Class T4 at 85°C (185°F) maximum ambient.	CS-E/FNN

Table 3. Analyzer/Transmitter Loop Approvals and Certifications

Testing Laboratory, Type of Protection, and Area Classification	Transmitter/Analyzer Electrical Safety Design Code (b)
CSA certified for use in general purpose (ordinary) locations	870PH; CS-E/CG-A 873PH; Code CGZ 873DPX; Code CGZ 875PH; Code C
CSA certified for use in Division 2 locations.	873DPX; Code CNZ 870ITPH; Code CNZ 875PH; Code C
CSA certified intrinsically safe in Division 1 locations.	870ITPH; Code CAA
FM approved for use in general purpose (ordinary) locations.	873PH; Code FGZ 873DPX; Code FGZ 875PH; Code F
FM approved nonincendive, Division 2 locations.	873PH; Code FNZ 873DPX; Code FNZ 870ITPH; Code FNZ 875PH; Code F
FM approved intrinsically safe, Division 1 locations.	870ITPH; Code FAA
UL approved for use in general purpose (ordinary) locations.	875PH; Code U

Sensor Identification

The 871A Sensor data labels (see Figure 2) are located approximately 300 mm (12 in) from each end of the sensor cable. The model code (the alphanumeric number to be used when ordering a replacement) is the top number (example: 871A-4F). The bottom number (example: 2B0545) is the manufacturing/date code.

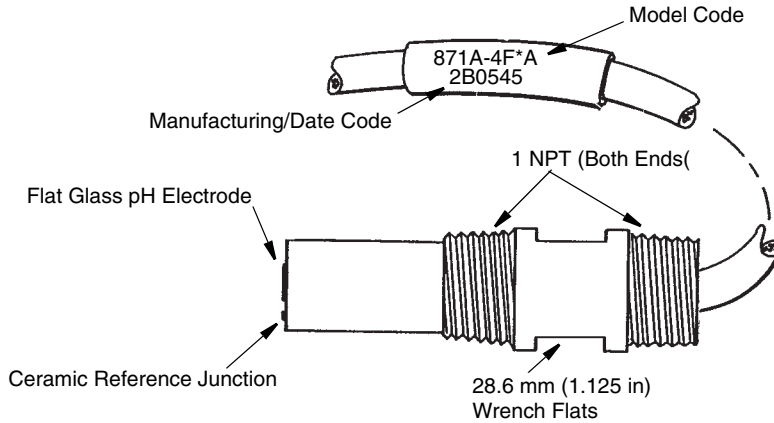

Figure 2. 871A Sensor Data Label

Sensor/Analyzer/Transmitter Compatibility

Table 4. Sensor/Analyzer/Transmitter Compatibility

Analyzer/ Transmitter	Sensor Signal Conditioning Code (a)			
	871A-1	871A-2 (c)	871A-3	871A-4
875PH (c)	15 m (50 ft) maximum	150 m (500 ft) maximum	15 m (50 ft) maximum	150 m (500 ft) maximum
873PH	15 m (50 ft) maximum	150 m (500 ft) maximum	Not Compatible	Not Compatible
873DPX	15 m (50 ft) maximum	150 m (500 ft) maximum	Not Compatible	Not Compatible
870ITPH (c)	15 m (50 ft) maximum	150 m (500 ft) maximum	15 m (50 ft) maximum	150 m (500 ft) maximum
870PH (b)	15 m (50 ft) maximum	30 m (100 ft) maximum	Not Compatible	Not Compatible

(a) Maximum = Maximum allowable cable length between sensor and analyzer or transmitter.

(b) When 870PH instrument is used with an 871A-1 sensor, use of a remote preamplifier (Part No. BS811MR) is required.

(c) 875PH Analyzer and 870ITPH Transmitter when used with the 871A-2 Sensor are compatible but without the full diagnostic suite.

Model Code

Description	Model
pH and ORP Sensor	871A
Signal Conditioning	
Standard Configuration, No Preamplifier	-1
Standard Configuration, Integral Preamplifier (a)	-2
Intelligent Configuration, No Preamplifier (b)	-3
Intelligent Configuration, Integral Preamplifier (b)	-4
Measuring Electrode and Material	
pH, Flat Glass	F
ORP, Platinum	D
ORP, Gold	E
Optional Integral Cable Selection	
Leads terminated with No. 6 spade terminals for Standard configuration sensors only (c)(h)	-1
Nonstandard Integral Cable Length (d)(h)	-3
Nonstandard Integral Cable Length terminated in male connector. Specify length. (e)(f)(g)	-5
Standard 3 m (10 ft) Integral Cable, terminated in male connector (e)(f)(g)	-7

(a) Does not support the diagnostic features of the 870ITPH Transmitter and 875PH Analyzer.

(b) Compatible with 870ITPH Intelligent Transmitter and 875PH Intelligent Analyzer only.

(c) All cables that do not have connectors have leads terminated with straight pin lugs and are now compatible with all Foxboro transmitters and analyzers. Option -1 does not provide spade lugs. Option -1 is included for users who automatically order it.

(d) Standard cable length is 3 m (10 ft). Maximum integral cable length is 15 m (50 ft).

(e) For use with 871A-2 only.

(f) Requires patch cord.

(g) Not compatible with ball valve assembly mountings.

(h) Except for the possible optional features combination (-13), only one optional selection may be chosen. Optional selections (-1) and (-3) may each be selected individually or as a combination.

2. Installation

Sensor Mounting

General Installation Guidelines

— **NOTE** —

All piping techniques should comply with standard and acceptable practices.

Proper mounting of the sensor is important for efficient and accurate operation.

For all applications and sensor configurations, mounting arrangements must be located so that:

- ◆ Sample at the sensing area is representative of the solution.
- ◆ Solution circulates actively and continuously past the sensing area (electrodes should stay wetted at all times).
- ◆ Flow velocity at sensing area does not cause cavitation or electrode damage.
- ◆ Position and orientation of the sensor does not trap air bubbles within the sensing area.
- ◆ Orientation of the sensor is in the vertical position (with electrodes at the bottom). However, the sensor will operate in a horizontal position – do *not* install the sensor in upside-down position.
- ◆ Accessibility for maintenance is considered. A flow-type installation must have blocking valves (user supplied) to allow for maintenance.
- ◆ Deposits of sediment or other foreign material do not accumulate within the sensing area.
- ◆ If cable is installed in metal conduit (recommended), either use flexible conduit or make some other provision for removal of the sensor from the process.

— **NOTE** —

The black threaded section of the sensor is made of electrically conductive, carbon-filled polyvinylidene fluoride (PVDF), which provides the solution ground connection for the measurement circuitry.

For proper sensor operation, the black threaded portion of the sensor must make electrical contact to the process. When installing in threaded bushings for installation in the process using ptfе tape, the amount of tape used should be minimized and positioned on the threads so that electrical contact between sensor threads and process piping is achieved. When installing in plastic, nonconductive, threaded bushings, the ptfе tape should not cover the bottom of the sensor threads and the sensor must be positioned so that solution contact to the threaded section is ensured.

Installation Using Sensor Threads

1. Wrap ptfе tape on the 1 NPT threads of sensor. See Note in “General Installation Guidelines” on page 17.
2. Insert the sensor into the tank/vessel (Figure 3) or pipe (Figure 4) and tighten to a maximum torque of 31 N•m (23 lb•ft).
3. See “Wiring” on page 28 for sensor lead connections.

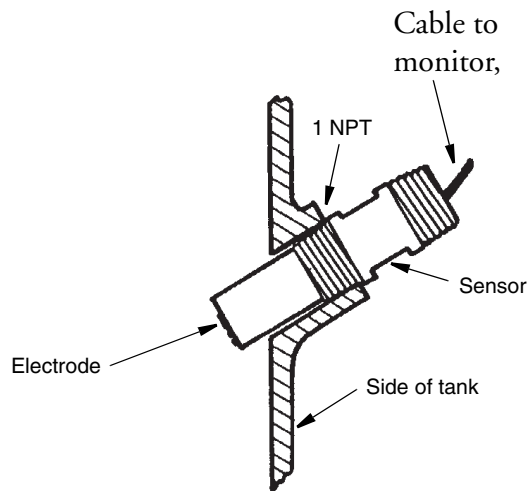

Figure 3. Side of Tank/Vessel Mounting

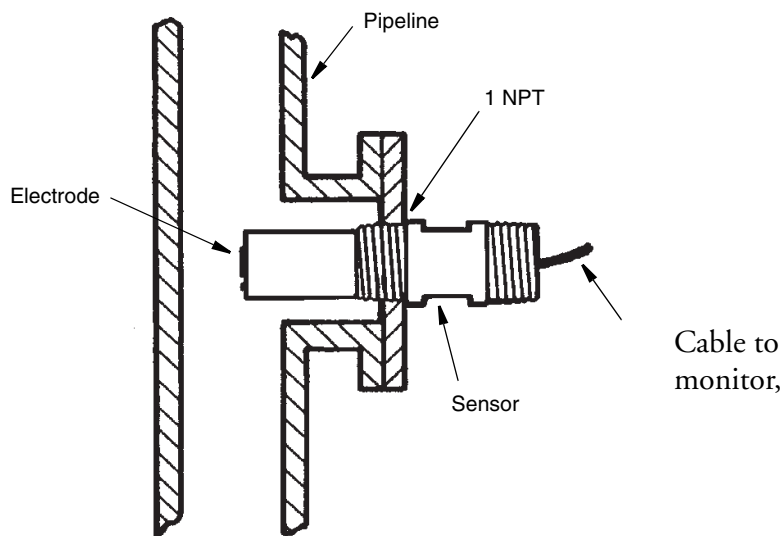

Figure 4. Pipe Mounting

Flow Chamber Installation

Flow chambers are a convenient way of mounting sensors in a system where a sample is provided by a small diameter sample line. The inlet and outlet ports of the flow chamber are provided with either ¼ NPT or ½ NPT internal threads and connect to the system with user supplied fittings. The flow chamber is offered in 316ss, PVDF, or CPVC. Refer to Table 5 for Flow Chamber specifications.

Table 5. Flow Chamber Specifications

Material	Process Inlet and Outlet	Part Number	Maximum Pressure/Temp Rating
316 ss	¼ NPT	BS805SP	500 psig at 175°C (347°F)
	½ NPT	BS805SS	
PVDF	¼ NPT	BS805SQ	60 psig at 50°C (122°F)
	½ NPT	BS805ST	
CPVC	¼ NPT	BS805SR	60 psig at 50°C (122°F)
	½ NPT	BS805SU	

⚠ WARNING

Do **not** exceed the pressure/temperature ratings of the materials used.

⚠ CAUTION

The flow chamber can pass up to 125 mL/s (2 gpm) of process sample without introducing a damagingly high pressure drop. To avoid damage to the sensor, do **not** exceed 125 mL/s (2 gpm).

— NOTE

All piping techniques should comply with standard and acceptable practices.

A flow chamber installation must meet mounting arrangements specified in “General Installation Guidelines” on page 17 as well as the following requirements:

- ◆ Mount the flow chamber so that the sensor is located between vertical and 45° with the electrodes facing down.
- ◆ Direct the outlet piping **upward** a minimum of 50 mm (2 in) so that bubbles do not settle in the measuring electrode.
- ◆ Provide space for removal of the sensor from the flow chamber.

Install the flow chamber as follows:

1. Drill the four mounting holes for the two U-bolt clamps.
2. Mount the flow chamber and connect the two ¼ NPT or ½ NPT user-supplied connections (see Figure 5).
3. Wrap ptfе tape on 1 NPT threads of sensor. See Note in “General Installation Guidelines” on page 17.

4. Insert the sensor into the flow chamber and tighten to a maximum torque of 31 N•m (23 lb•ft).
5. Fill and pressurize the flow chamber as required. Check for and eliminate leaks.
6. See “Wiring” on page 28 for sensor lead connections.

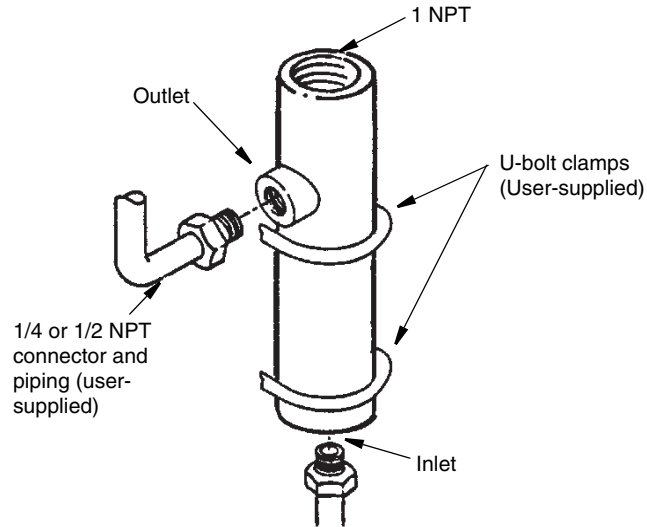

Figure 5. Flow Chamber Installation

Bushing Installation

Bushings are used to mount sensors in a system that has process piping larger than the 1-inch external NPT connection of the sensor. Bushings are offered with 1/4-inch or 1/2-inch external NPT connections, and are available in either 316 ss, PVDF, or CPVC. Refer to Table 6 for bushing specifications and to Figure 7 for a typical bushing installation.

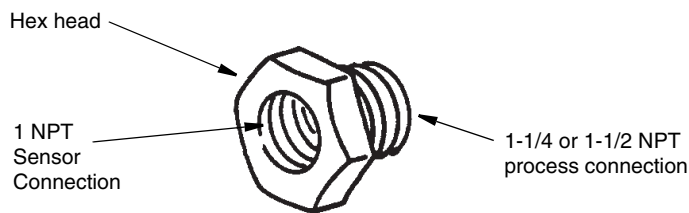
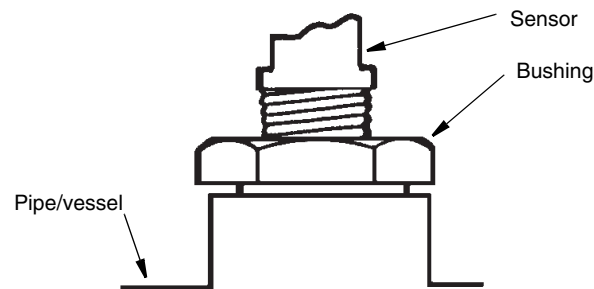

Figure 6. Bushing

Table 6. Bushing Specifications

Bushing Material	Process Connection	Part Number	Maximum Pressure/Temp Rating
316 ss	1¼ NPT 1½ NPT	BS805TD BS805TF	200 psig at 120°C (248°F)
PVDF	1½ NPT	BS805TG	100 psig at 55°C (131°F) 37 psig at 120°C (248°F)
CPVC	1¼ NPT 1½ NPT	BS805TE BS805TH	200 psig at 60°C (140°F) 60 psig at 100°C (212°F)

*Figure 7. Typical Bushing Installation*

Install the sensor in a bushing as follows:

⚠ WARNING

Do **not** exceed the pressure/temperature ratings of the materials used.

1. Wrap ptfе tape on 1 NPT threads of sensor. See Note in “General Installation Guidelines” on page 17.
2. Insert the sensor into the bushing and tighten to a maximum torque of 31 N•m (23 lb•ft).
3. See “Wiring” on page 28 for sensor lead connections.

Tee Installation

Tees are used for flow-through installations in a pipe line. The sensor connection end and process inlet and outlet ports have internally threaded ends for the 316 ss and PVDF Tee materials, and internal pipe socket weld connections for the CPVC Tee material. Reducing bushings are used on the sensor end, and also on the process ends (as required) to accommodate the 1 NPT sensor and various process connection sizes. Refer to Table 7 for Tee specifications and Figure 9 for a typical Tee installation.

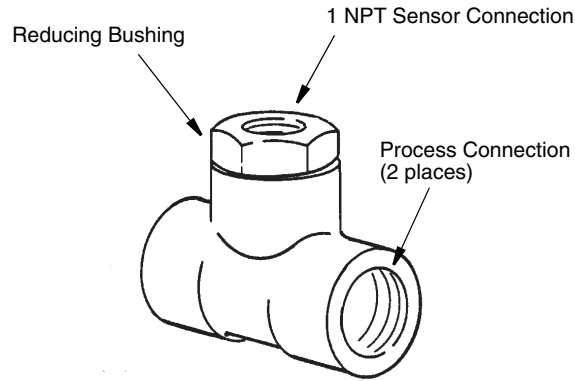

Figure 8. Tee

Table 7. Tee Specifications

Tee Material	Process Connections	Part No.	Maximum Pressure/Temp Rating
316 ss	1 NPT 1¼ NPT 1½ NPT	BS805SV BS805SY BS805TA	150 psig at 175°C (347°F)
PVDF	1 NPT 1½ NPT	BS805SW BS805TB	100 psig at 55°C (131°F) 37 psig at 120°C (248°F)
CPVC	33 mm (1.3 in) I.D. ^(a) 41 mm (1.6 in) I.D. ^(a) 48 mm (1.9 in) I.D. ^(a)	BS805SX BS805SZ BS805TC	150 psig at 40°C (104°F) 50 psig at 95°C (203°F)

(a) Pipe socket-weld.

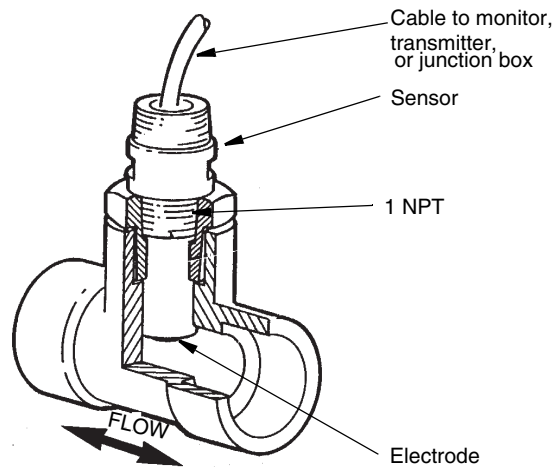

Figure 9. Typical Tee Installation

Install the sensor in a bushing as follows:

⚠ WARNING

Do **not** exceed the pressure/temperature ratings of the materials used.

1. Wrap ptfе tape on 1 NPT threads of sensor. See Note in “General Installation Guidelines” on page 17.
2. Insert the sensor into the tee and tighten to a maximum torque of 31 N•m (23 lb•ft).
3. See “Wiring” on page 28 for sensor lead connections.

Electrode Protection Sleeve Installation

The electrode protection sleeve (part number BS805TJ) protects glass electrodes from contacting the bottom or side of a tank. This PVDF sleeve [with a maximum temperature rating of 135°C (275°F)] is applicable to submersible applications.

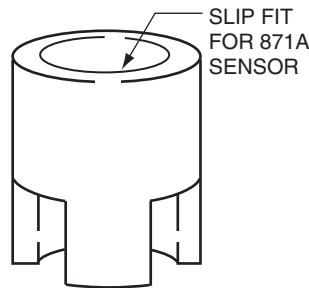

Figure 10. Electrode Protection Sleeve

Submersion/Immersion Installations

For Submersion/Immersion installations, it is recommended that the sensor be supported by a length of pipe (user-supplied) in a tank or stream. The sensor cable should be protected from damage by using user supplied conduit.

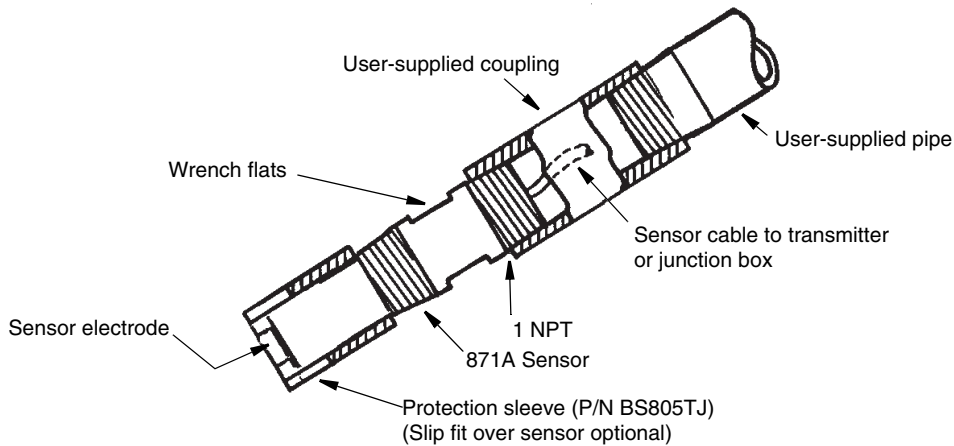

Figure 11. Submersion/Immersion Installation

Install the sensor as follows:

NOTE

The black portion of the sensor must be in contact with the process fluid.

1. Slide an electrode protection sleeve over electrode end of sensor (optional).
2. Wrap ptfе tape on the 1 NPT threads nearest the cable end of the sensor.
3. Attach a 1 NPT (internally threaded on both ends) coupling to the sensor. Tighten to a maximum torque of 31 N•m (23 lb•ft).
4. Slide a 1 NPT externally threaded length of pipe (user supplied) over the sensor cable and thread the pipe into the coupling.
5. See “Wiring” on page 28 for sensor lead connections.

Installation Using Ball Valves

NOTE

The ball valve assembly permits an 871A sensor to be inserted and removed from a process stream or tank under rated temperature and pressure without draining the system or resorting to a bypass arrangement. The assembly consists of the ball valve unit and an insertion shaft assembly. A standard flexible conduit (user-provided) can be used for cable protection. For ball valve assembly specifications, see Table 8.

Table 8. Ball Valve Assembly Specifications

Process Line Connection	Materials of Process Wetted Parts ^(a)				Rated Pressure ^(b)		Max Temp ^(b) at Rated Pressure		Part No.
	Process Connection and Housing	Ball Seat	Ball Valve	O-Ring	MPa	psi	°C	°F	
1-1/2 NPT	316 ss	ptfe	Glass-filled Polypropylene	EPR	1.0	145	20	68	BS806AN
					0.4	55	65	149	
					0.07	10	88	190	
1-1/2 NPT	Titanium	ptfe	Kynar	EPR	1.6	230	20	68	BS806EP
					1.0	145	60	140	
					0.35	50	140	284	

(a) Refer to Global Customer Support for other materials.

(b) Actual application rating may be reduced by sensor pressure/temperature rating. Refer to Figure 1.

A ball valve assembly installation must meet mounting arrangements specified in “Sensor Mounting” on page 17. In addition, please adhere to the following requirements:

- ◆ Direct the flow of the solution (as much as possible) toward the sensing area.
- ◆ Provide sufficient space for removal of the sensor from the ball valve unit (see DP 611-157).

Installing the Ball Valve Assembly Into the Process

1. Unscrew the housing nut and remove the insertion shaft assembly.
2. Close the ball valve by turning the handle so that it is perpendicular to the housing (as indicated by the arrow on top of the handle).
3. Screw the 1 1/2 NPT nipple of the ball valve into the process vessel. Tighten as required.

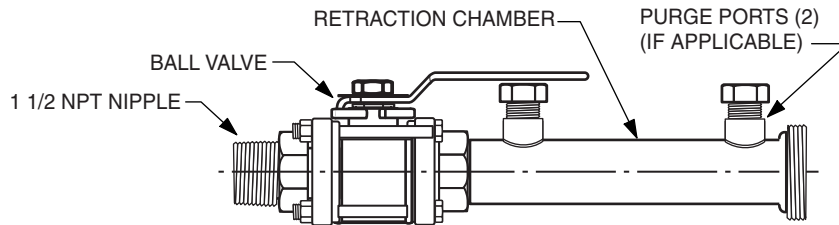

Figure 12. Ball Valve Assembly

4. Connect appropriate piping to the purge ports of the retraction chamber (if applicable).

Connecting the Sensor to the Insertion Shaft Assembly

1. Wrap ptfе tape onto the threads of the sensor nearest the cable end.
2. Feed the sensor cable through the shaft assembly. Screw the shaft assembly into the end of the sensor (finger tight). See Figure 13. Do **not** overtighten.

NOTE

To prevent the cable from twisting, it is recommended that this be done by holding the sensor and turning the insertion shaft.

3. Lightly lubricate the shaft and O-ring on the seal with silicone grease (or equivalent).

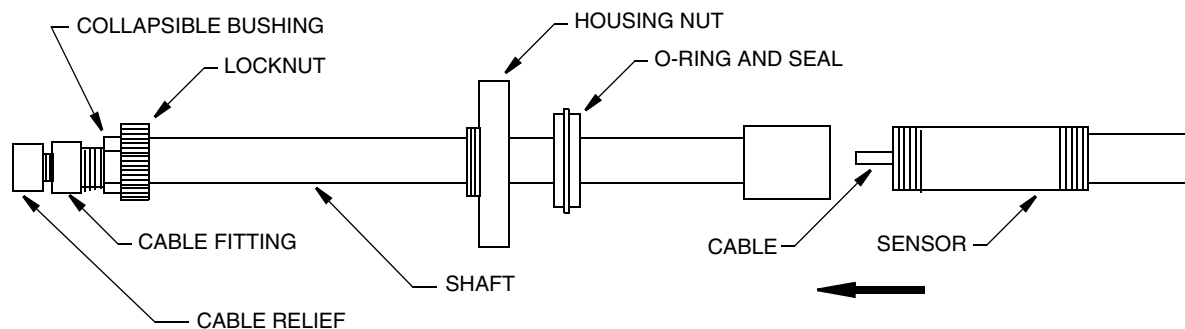

Figure 13. Insertion Shaft Assembly

Installing the Insertion Shaft into the Ball Valve

WARNING

Do not exceed the sensor or ball valve temperature and pressure limits.

WARNING

Stand to the side, not directly behind the assembly, during insertion and retraction of the sensor.

NOTE

The sensor should have been connected to the insertion shaft assembly prior to performing this procedure. See “Connecting the Sensor to the Insertion Shaft Assembly” on page 26.

1. Assure that the ball valve is closed. The handle should be perpendicular to the housing (as indicated by the arrow on top of the handle).
2. Fill and pressurize the process line or tank as required. Check for and eliminate leaks.
3. Lightly lubricate the shaft with silicone grease (or equivalent).
4. Slide the O-ring and seal along the insertion shaft towards the sensor as far as it goes.

⚠ CAUTION

Failure to do this makes it possible for the sensor to contact the closed ball valve when performing the next step. Such contact could damage the sensor.

- Carefully insert the sensor (connected to the insertion shaft assembly) into the housing retraction chamber until the O-ring and seal are seated into the end of the chamber (see Figure 14).

⚠ CAUTION

Do **not** nick the O-rings. Do **not** force the electrodes against the closed ball valve.

- Tighten the housing nut onto the end of the retraction chamber.
- Slowly turn the handle on top of the ball valve unit (see Figure 14) to the open position (parallel to the housing as indicated by the arrow on top of the handle).

⚠ WARNING

Depending on the condition of the seal, process seepage is possible as you perform the next step.

⚠ CAUTION

Failure to open the ball valve causes the sensor to contact the closed ball valve when performing the next step. Such contact could damage the sensor.

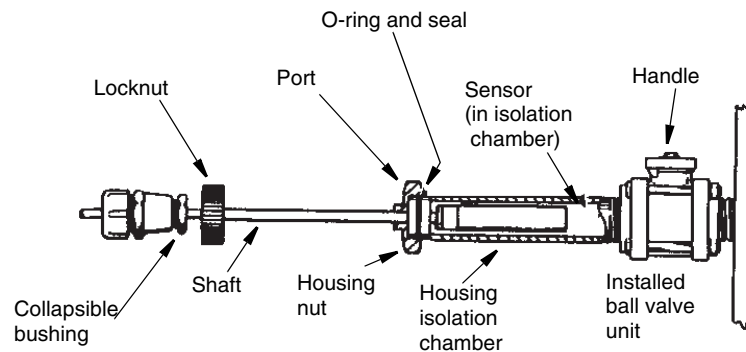

Figure 14. Ball Valve Shaft Installation and Removal

- Insert the shaft slowly until the locknut reaches the housing nut. Tighten the locknut onto the housing nut. When this is done, the sensor is inserted at a depth of 70 mm (2.8 in).
- Push the collapsible bushing against the locknut.
- Screw the cable fitting onto the collapsible bushing.
- Tighten the cable relief until it captures the cable.

Removing and Replacing a Sensor

⚠ WARNING

Stand to the side, not directly behind the assembly, during removal or insertion of the sensor.

⚠ WARNING

If process fluid is present, there could be some process seepage as you perform Steps 2 and 5. Take all necessary precautions.

⚠ WARNING

Do **not** loosen the **housing nut** (see Figure 14) when the ball valve unit is open and the process line or tank is filled and pressurized.

1. Carefully loosen and detach the locknut **only**. Do **not** loosen the housing nut at this time.
2. Pull the insertion shaft out of the process as far as you can. This positions the sensor in the retraction chamber.
3. Close the ball valve by turning the handle so that it is perpendicular to the housing (as indicated by the arrow on top of the handle).
4. Flush and drain the purgable retraction chamber (if applicable). Then close the purge fittings.
5. Slowly loosen and detach the housing nut. Withdraw the shaft assembly from the housing retraction chamber.
6. Remove the cable fitting and cable relief from the insertion shaft.
7. Unscrew and remove the sensor from the insertion shaft.
8. Perform “Connecting the Sensor to the Insertion Shaft Assembly” on page 26.
9. Perform “Installing the Insertion Shaft into the Ball Valve” on page 26.

Electrode Cleaning System

For information on the Electrode Cleaning System, refer to MI 611-125.

Wiring

Connections to Analyzer or Transmitter

Connect the numbered wires from the sensor to the appropriate terminals on the transmitter, analyzer, or junction box. For sensor connections to an analyzer or transmitter, refer to Table 9 through Table 12. Extension cables and patch cords have the same numbering and color coding as the sensor cables.

Table 9. Analyzer and Transmitter Connections

Instruction	Analyzer or Transmitter
MI 611-155	870PH pH and ORP Transmitters
MI 611-165	873PH Series Electrochemical Analyzers for pH or ORP Measurement
MI 611-190	873DPX Dual pH, ORP, or ISE Electrochemical Analyzers
MI 611-211	870ITPH pH and ORP Transmitters
MI 611-225	875PH pH and ORP Analyzers

Table 10. Sensor (871A-1 and -3) Without Preamplifier

Cable Number	Cable Color	Function
1	Black	Signal from RTD in Sensor
2	White or Dark Green ^(a)	Signal from RTD in Sensor
3	White or Clear ^(a)	Measuring Electrode
3A	Clear	Shield (screen) for Measuring Electrode
4	Green	Solution Ground
5	Red	Reference Electrode

(a) Depending on shipment date.

Table 11. Sensor (871A-2 Series) With Preamplifier

Cable Number	Cable Color	Function
1	Black	Signal from RTD in Sensor
2	White	Signal from RTD in Sensor
3	Red	Measurement Signal (-)
4	Green or Clear ^(a)	Solution Ground
5	Orange or Yellow ^(a)	Measurement Signal (+)
6	Brown	Power to Sensor (+)
7	Blue	Power to Sensor (-)

(a) Depending on shipment date.

Table 12. Sensor (871A-4 Series) with Preamplifier

Cable Number	Cable Color	Function
1	Black	Signal from RTD in Sensor
2	White	Signal from RTD in Sensor
2A	Orange	Signal from RTD in sensor
3	Red	Measurement Signal (-)
4	Clear	Solution Ground
5	Yellow	Measurement Signal (+)
6	Brown	Power to Sensor (+)
7	Blue	Power to Sensor (-)
8	Green	Diagnostic Signal

Cable Variations

Sensor cables are permanently attached to the sensor. Additional length can be achieved through the use of an extension cable with a junction box, remote preamplifier, or connector plug. See Figures 15 through 18 for typical cable configurations.

Cable Length

In most cases, when a internal preamplifier or remote preamplifier is used, the analyzer/transmitter can be up to 152 m (500 ft) away from the sensor. If no preamplifier is used, the distance is limited to 15 m (50 ft).

— NOTE —

It is recommended that the users order the sensor cable with the correct length and termination for their application so that it does not have to be cut in the field. If the cable does have to be cut, contact Global Customer Support at one of the phone numbers on the last page of this document for cable termination advice.

871A-1 Sensor (Without Internal Preamplifier)

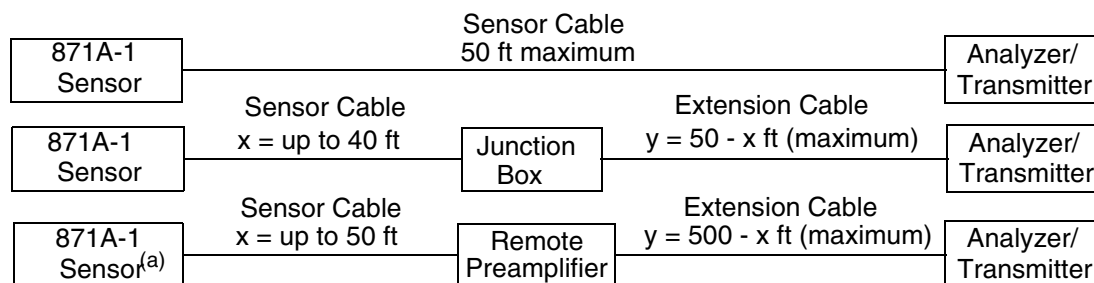

(a) When 871A-1 Sensor is used with an 870PH Transmitter, a remote preamplifier is required and $y = 50-x$ ft maximum

Figure 15. Cable Lengths for 871A-1 Sensors

871A-2 Sensor (With Internal Preamplifier)

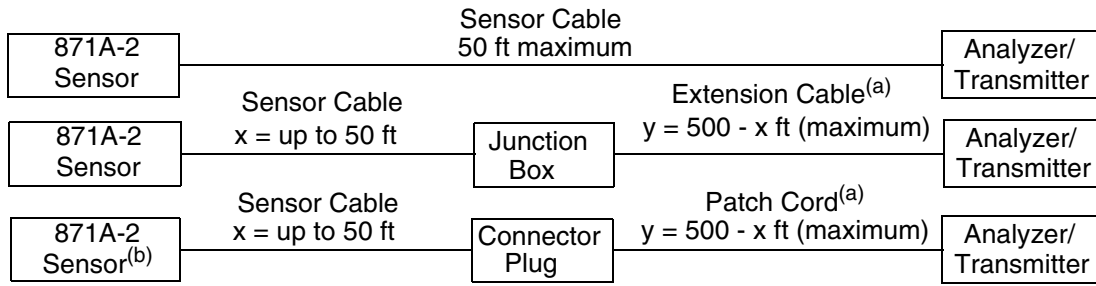

(a) $y = 100 - x$ ft maximum with 870PH Transmitter
 (b) With -5 or -7 Cable Option

Figure 16. Cable Lengths for 871A-2 Sensor

871A-3 Sensor (Without Internal Preamplifier)

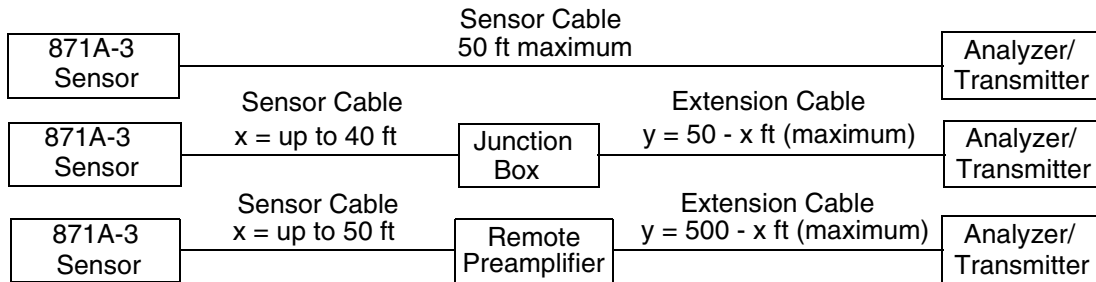

Figure 17. Cable Lengths for 871A-3 Sensors

871A-4 Sensor (With Internal Preamplifier)

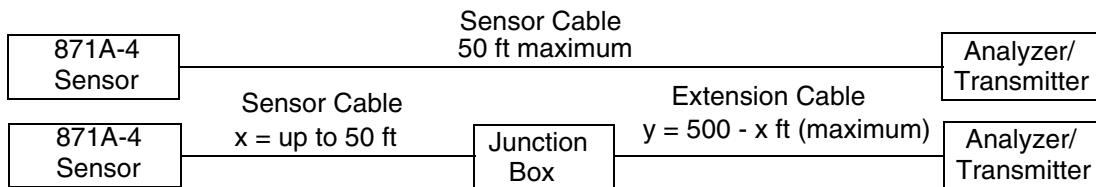

Figure 18. Cable Lengths for 871A-4 Sensor

3. Preventive Maintenance

Standardization

Refer to “Reference Documents” on page 10 for the appropriate analyzer or transmitter instruction.

Electrode Inspection

Fouling (the build-up of a film) on the measuring electrode and the reference junction can cause erratic output.

Inspect the electrodes as needed. Once a week is recommended for new installations. If fouling is evident, clean the electrode as described in the following sections.

Cleaning Glass Electrode

First, consider the contamination you are trying to remove. In what is it soluble? What will chemically attack it? Next, consider the sensor. What cleaner will have little or no effect on the sensor itself? Choose the solvent, soap, or chemical that is the mildest but removes the contamination. Caustic is a risky choice for glass electrodes. Stronger concentrations can attack the glass. Dilute HCl (muriatic acid) is frequently a good choice. The concentration of HCl should be as low as possible and still remove the contamination. Consider 4% or 1 N to be a maximum.

⚠ CAUTION

Do not clean glass electrodes with abrasive cleaners or coarse wipers.

⚠ CAUTION

Handle the sensor very carefully to avoid damage to the glass electrode.

Rinse the electrode with distilled water. Blot the electrode and reference junction with a soft cloth.

In hard-water areas, dip the tip of the sensor in a 1 to 4% solution of HCl to remove surface film. Then rinse thoroughly.

If the electrode surface is oily, clean it with a mild detergent and fine bristle brush.

Cleaning ORP Electrode

ORP electrodes rarely require cleaning. They can be cleaned with detergent and a fine bristle brush.

Cleaning Reference Junction

Clean the reference junction with detergent and a fine bristle brush. If the system fails to improve, the reference junction is fouled.

Storing a Sensor

The shelf life of your sensor depends on the storage conditions. Although a shelf life is not specified, a reasonable estimate is 6 to 12 months. Under the best conditions, sensors may last well over a year on the shelf.

The key to proper storage is keeping both the measuring electrode and the reference junction hydrated at normal room temperature. Store your sensor in a 1 M potassium chloride solution or a pH 4 or pH 7 buffer solution. Sensors should not be stored in distilled or deionized water. New sensor assemblies are shipped with the measuring and reference junction sealed in a protection cap containing liquid potassium chloride salt solution. The cap should remain in place until you are ready to install your sensor in the process. The protection cap can be reused to store a sensor by replenishing the solution and fitting it on to the sensor. This is recommended if the sensor is removed from the process for more than a few hours. Proper storage maximizes both shelf life and service life of a sensor.

4. Sensor Troubleshooting

871A-1 and -3 Sensor (Without Preamp) (Without Preamp)

1. Disconnect the sensor leads 1 and 2 from the analyzer/transmitter or remote preamplifier. Use an ohmmeter to measure the resistance between leads 1 and 2 (black and white). The resistance should be between 100 and 140 Ω for 871A-1 Sensors and 1000 Ω and 1400 Ω for 871A-3 Sensors (refer to Table 13). If this check is not OK, sensor must be replaced.
2. Remove the sensor from the process. Thoroughly clean the sensor body with distilled water and dry the body completely. With sensor leads connected to the analyzer/transmitter or preamplifier, use an ohmmeter to measure between the black threaded section of the sensor body and terminal #4. Resistance should be less than 1 k Ω . If this check is not OK, sensor must be replaced. If this check is OK, proceed to Step 3.

Table 13. Process Temperature vs. Temperature Sensor Resistance

Process Temperature		RTD Resistance	
		871A-1, -2	871A-3, -4
$^{\circ}\text{C}$	$^{\circ}\text{F}$	Ω	
-5	+20	98.04	980.4
0	32	100.00	1000.0
10	50	103.90	1039.0
20	68	107.79	1077.9
25	75	109.73	1077.9
30	86	111.67	1116.7
40	104	115.54	1155.4
50	122	119.40	1194.0
60	140	123.24	1232.4
70	158	127.07	1270.7
80	176	130.89	1308.9
90	194	134.70	1347.0
100	212	138.50	1385.0
105	225	140.39	1403.9
110	230	142.28	1422.8
120	248	146.06	1460.6
130	266	149.82	1498.2
160	320	161.04	1610.4

3. Disconnect all sensor leads from the analyzer/transmitter or remote preamplifier. Make all the following resistance checks with an ohmmeter. If any of these checks is not OK, sensor must be replaced.

Measure Between These Two Sensor Leads	Resistance Should Be
2 to either 3, 3A, 4 or 5	infinite
3 to either 3A, 4 or 5	infinite
3A to either 4 or 5	infinite
4 to 5	infinite

871A-2 and A-4 Sensor (With Preamplifier)

1. Disconnect sensor leads 1 and 2 from the analyzer or transmitter. Use an ohmmeter to measure the resistance between leads 1 and 2 (black and white). Resistance should be between 100 and 140 Ω for an 871A-2 Sensor and 1000 and 1400 Ω for an 871A-4 Sensor. (Refer to Table 13). If this check is not OK, sensor must be replaced. If this check is OK, proceed to Step 2.
2. Remove the sensor from the process. Thoroughly clean the sensor body with distilled water and dry the body completely. With sensor leads connected to the analyzer or transmitter, use an ohmmeter to measure between the black threaded section of the sensor body and terminal #4. Resistance should be less than 1 k Ω . If this check is not OK, sensor must be replaced. If this check is OK, proceed to Step 3.
3. Leave all sensor leads connected to the analyzer or transmitter. Leave power on the analyzer or transmitter. Use a voltmeter to measure the voltage between terminals 4 and 6, then 4 and 7 (green and brown, then green and blue).
 - ◆ With an 870PH Transmitter, voltage should be approximately ± 5.5 V.
 - ◆ With an 873 Analyzer, voltage should be approximately ± 6.2 V.
 - ◆ With an 870ITPH Transmitter, voltage should be approximately +5 V between terminals 6 and 4, and -2.5 V between 7 and 4.
 - ◆ With an 875PH Analyzer, voltage should be approximately +5 V between terminals 6 and 4, and -5 V between 7 and 4.

If above check is OK, proceed to Step 4. If check is not OK, continue as follows:

Disconnect sensor leads 4, 6, and 7 from analyzer or transmitter. Repeat the voltage checks above (measure at the analyzer or transmitter, not at the sensor leads). If voltage checks are not OK, the sensor must be replaced. If checks are not OK, there is a problem in the analyzer or transmitter.

4. Reconnect all sensor leads to the analyzer or transmitter. Leave power on the analyzer or transmitter. Clean the pH electrode and reference junction. Place the sensor in a pH 7 buffer solution. Use a voltmeter to measure the voltage between terminals 3 and 5 (red and orange). The voltmeter should read approximately 0 mV in pH 7 buffer, and should change approximately 59 mV per pH unit (e.g., in pH 4 buffer, the reading should be approximately +177 mV; in pH 10 buffer, the reading should be approximately -177 mV).

If above check is OK, and there is still a problem with the measurement, the problem resides in the analyzer or transmitter. If above check is not OK, proceed to Step 5.

5. Disconnect sensor leads 3 and 5 from the analyzer or transmitter. Repeat the voltage checks described in Step 4 except make the measurements at the sensor leads. If voltage checks are OK, there is a problem in the analyzer or transmitter. If voltage checks are not OK, the sensor must be replaced.

Index

B

- Ball Valve Installation 24
- Bushing Installation 20

C

- Cable Length 30
- Cautions 9
- Cleaning
 - Glass Electrode 33
 - ORP Electrode 33
 - Reference Junction 34
- Compatibility, Sensor/Analyzer/Transmitter 14
- Connection of Sensor to Insertion Shaft Assembly 26
- Connections, Wiring 28

D

- Dangers 9

E

- Electrode Cleaning System 28
- Electrode Inspection 33
- Electrode Protection Sleeve Installation 23

F

- Flow Chamber Installation 19

I

- Identification, Sensor 14
- Installation 17
 - Ball Valves 24
 - Bushing 20
 - Electrode Protection Sleeve 23
 - Flow Chamber 19
 - General Guidelines 17
 - Sensor Threads, Using 18
 - Submersion/Immersion 23
 - Tee 21

M

Maintenance, Preventive 33
Model Code 15

R

Reference Documents 10

S

Sensor Mounting 17
Specifications
 Electrical Safety 13
 Standard 12
Standardization 33
Storing a Sensor 34
Submersion/Immersion Installations 23

T

Tee Installation 21
Theory of Operation 10
Troubleshooting 35

W

Warnings 9
Wiring 28

ISSUE DATES

MAY 1988	AUG 2006
MAY 1995	NOV 2008
JAN 1997	FEB 2016
OCT 1997	

Vertical lines to the right of text or illustrations indicate areas changed at last issue date.