

Model IGP50 I/A Series[®] Premium Performance Gauge Pressure Transmitter with HART[®] or FOUNDATION[™] Fieldbus Communication Protocol



The Foxboro[®] brand I/A Series[®] Model IGP50 is an intelligent, premium performance, two-wire transmitter that provides precise, reliable measurement of gauge pressure using only two sensors to provide a very wide measurement range. It transmits a 4 to 20 mA or digital output signal, as applicable, using HART[®] or FOUNDATION[™] Fieldbus communication protocol for remote configuration, calibration, and monitoring.

FEATURES

- ▶ Silicon strain gauge sensors successfully field-proven in many thousands of installations.
- ▶ Wide measurement spans from 17 to 14 000 kPa (2.5 to 2000 psi) using only two sensors, each having 80:1 turndown capability.
- ▶ Very wide measurement range using only two sensors.
- ▶ Local configuration available with the optional LCD Indicator with on-board pushbuttons.
- ▶ Durable aluminum or 316 ss housing available; both meet NEMA 4X and IP66 ratings.
- ▶ Industry standard 316L ss offered for process connection and sensor wetted parts material.
- ▶ Digital precision, stability, and resolution ensure premium measurement performance with accuracy of $\pm 0.025\%$ of calibrated span for spans $\geq 10\%$ of URL.
- ▶ Simple, elegant sensor design uses very few parts to achieve exceptionally high reliability. All welded sensor assembly requires no gaskets to contain process pressure.
- ▶ Designed for hazardous areas; and versions available for Agency flameproof and zone requirements.
- ▶ FOUNDATION Fieldbus versions are FISCO and FNICO compliant.
- ▶ Complies with applicable EMC, ATEX, and PED European Directives. See inside pages.
- ▶ Dual Seal Certified by CSA to meet ANSI/ISA 12.27.01-2003 requirements.
- ▶ Multi-marking is available for HART electronic versions for FM, CSA, and ATEX intrinsically safe installations. The user determines and permanently marks on the data plate the certification to be applied.
- ▶ Optional mounting bracket sets allow pipe or surface mounting. Numerous other options available.
- ▶ Standard 5-year warranty; 17-year optional.

I/A Series PRESSURE TRANSMITTER FAMILY

The I/A Series Electronic Pressure Transmitters are a complete family of d/p Cell®, gauge, absolute, multirange, multivariable, and premium performance transmitters, as well as transmitters with remote or direct mount seals, all using field-proven silicon strain gauge sensors and common topworks.

EXCEPTIONAL VALUE

The combination of small size, light weight, direct mounting, standard materials, and wide measurement capability with premium performance make this an exceptionally cost effective solution for process pressure measurement.

PREMIUM PERFORMANCE

These transmitters provide $\pm 0.025\%$ of span accuracy for spans $\geq 10\%$ of URL making them the most versatile of the “premium” or “reference class” transmitters available.

The transmitters have $\pm 0.02\%$ URL per year stability over a five year period and use characterization and microprocessor-based corrections to achieve excellent ambient temperature compensation.

These premium performance specifications result in an extremely low Total Probably Error (TPE) for the IGP50 transmitter.

VERY WIDE MEASUREMENT RANGE USING ONLY TWO SENSORS

Two gauge pressure range sensors are provided to cover measurement spans from 17 to 14,000 kPa (2.5 to 2000 psi). The high turndown capability of the transmitter means that nearly all gauge pressure applications can be satisfied with only these two ranges, greatly simplifying your spare transmitter and spare parts requirements.

DIRECT PROCESS MOUNTING

Because of their light weight and external threaded connection, these transmitters can be installed directly on process piping without mounting brackets. However, for unique requirements, optional bracket sets are offered and connection can be made to the standard 1/4 NPT internal thread.

STANDARD 316L ss PROCESS WETTED PARTS

With process connection and sensor diaphragm available in industry standard 316L ss, this transmitter is an excellent choice for the vast majority of process pressure measurements.

EASE OF INSTALLATION

Rotatable Topworks allows transmitter installation in tight places, allows indicator to be positioned in preferred direction, and eases field retrofit.

Two Conduit Entrances offer a choice of entry positions for ease of installation and self-draining of condensation regardless of mounting position and topworks rotation.

Wiring Guides and Terminations provide ease of wire entry, plenty of space to work and store excess wire, and large, rugged screw terminals for easy wire termination.

DIGITAL AND 4 TO 20 mA OUTPUT VERSIONS

The IGP50 is offered with HART or FOUNDATION Fieldbus protocols. See below.

Digital HART and 4 to 20 mA dc (Version -T Electronics)

4 to 20 mA with HART communications. Allows direct analog connection to common receivers while still providing full Intelligent Transmitter Digital Communications using a PC-based Configurator, HART Communicator, or optional LCD Indicator for local configuration and control.

Digital FOUNDATION Fieldbus (Version -F Electronics)

This all digital, serial, two-way communication system interconnects field devices, such as transmitters, actuators, and controllers. It is a Local Area Network (LAN) with built-in capability to distribute control application across the network. Fieldbus technology consists of a Physical Layer, a Communication Stack, and User Application Blocks. The Communication Stack includes an LAS (Link Access Scheduler), and the User Application Blocks include AI (Analog Input) and PID (proportional, integral, derivative) function blocks. Interoperability of devices is achieved using device IDs and DDs.

COMPLIANCE WITH EUROPEAN UNION DIRECTIVES

- ▶ Complies with Electromagnetic Compatibility Requirements of European EMC Directive 2004/108/EC by conforming to the following EN and IEC Standards: EN 61326-1, and IEC 61000-4-2 through 61000-4-6.
- ▶ Complies with NAMUR NE 21 Interference Immunity Requirement (EMC).
- ▶ Analog output complies with NAMUR NE 43 overrange and underrange annunciations.
- ▶ CE marked; complies with applicable EMC, ATEX, and PED European Union Directives.

FISCO/FNICO COMPLIANT

FOUNDATION Fieldbus (Electronic Version -F) certified by ATEX and IECEx for FISCO field device intrinsically safe, and FNICO field device protection n installations. Also certified for intrinsically safe and nonsparking user entity parameters.

HAZARDOUS AREA INSTALLATIONS

See Electrical Safety Specifications section. Also see Figure 1 for a conventional and flameproof transmitter.

OPTIONAL LCD DIGITAL INDICATOR

A two-line digital indicator with on-board pushbuttons is available to display the measurement with a choice of units. The pushbuttons allow zero and span adjustments, as well as local configuration, without the need for a remote PC-based configurator. See Figure 3.

Figure 1. IGP50 Transmitters (Flameproof Version Shown on Left)



FUNCTIONAL SPECIFICATIONS

Span and Range Limits

Span Limit Code	Span Limits			Range Limits		
	MPa	psi	bar	MPa	psi	bar
D	0.017 and 1.4	2.5 and 200	0.17 and 14	0 and 1.4	0 and 200	0 and 14
E	0.17 and 14	25 and 2000	1.7 and 140	0 and 14	0 and 2000	0 and 140

Maximum Overage and Proof Pressure Ratings

Span Limit Code	Maximum Overage Pressure Rating (a)			Proof Pressure Rating (b)		
	MPa	psi	bar	MPa	psi	bar
D	2.1	300	21	5.6	710	56
E	21	3000	210	56	7100	560

a. Maximum overrange pressure is the maximum pressure that may be applied without causing damage to the transmitter.
 b. Proof pressure ratings meet ANSI/ISA Standard S82.03-1988. Unit may become nonfunctional after application of proof pressure.

Output Signal and Configuration

HART Protocol

4 to 20 mA, with digital HART communications. For multidrop applications, the mA signal is fixed at 4 mA to provide power to the device. Configurable using a PC-based Configurator, a HART communicator, or optional LCD Indicator with on-board pushbuttons.

FOUNDATION Fieldbus Protocol

This digital, serial, two-way communication system runs at 31.25 kbits/s. The digital output signal is superimposed on the dc power signal on the bus, and controlled by a strict cycle schedule and protocol. Configurable using Host Computer (I/A Series system or a PC) having a Fieldbus interface PWA, or optional LCD Indicator with on-board pushbuttons.

Electronics and Sensor Temperatures

Readable from I/A Series system, Fieldbus Host System, PC-based Configurator, or HART Communicator. Measurement is transmitter temperature at the sensor and the electronics module, not necessarily process temperature.

Field Wiring Reversal

No transmitter damage. Note that FOUNDATION Fieldbus is polarity independent.

Adjustable Damping

The transmitter response time is normally 0.75 s, or the electronically adjustable setting of 0.00 (none), 0.25, 0.50, 1, 2, 4, 8, 16, or 32 seconds, whichever is greater, for a 90% recovery from an 80% input step as defined in ANSI/ISA S51.1. With Fieldbus, damping can be set in both the transducer and AI blocks.

Suppressed Zero

Suppressed zero ranges are acceptable as long as the Span and Range Limits are not exceeded.

Supply Voltage

HART 4 to 20 mA Output (Figure 2)

Nominal minimum supply voltage is 11.5 V dc. This value can be reduced to 11 V dc by using a plug-in jumper across the test receptacles in the field wiring compartment terminal block. Foxboro offers an optional plug-in shorting bar for this purpose.

FOUNDATION Fieldbus Digital Output

9 to 32 V dc, by a specific fieldbus power source connected to the bus. For intrinsically safe (I.S.) applications, the supply voltage allowed can vary depending on the rating of the I.S. barrier.

Zero and Span Adjustments

Zero and span adjustments can be initiated from the I/A Series Workstation (with applicable FBMs), a HART Communicator, a PC-based Configurator, or the optional LCD Indicator with on-board pushbuttons.

Zeroing for Nonzero-Based Ranges

Dual Function Zeroing is provided to allow zeroing with the transmitter open to atmosphere, even when there is a nonzero-based range. This greatly simplifies position effect zeroing on many pressure and level applications. It even applies to the LCD Indicator and External Zero Adjustment options.

Figure 2. 4 to 20 mA Output, Supply Voltage vs. Output Load

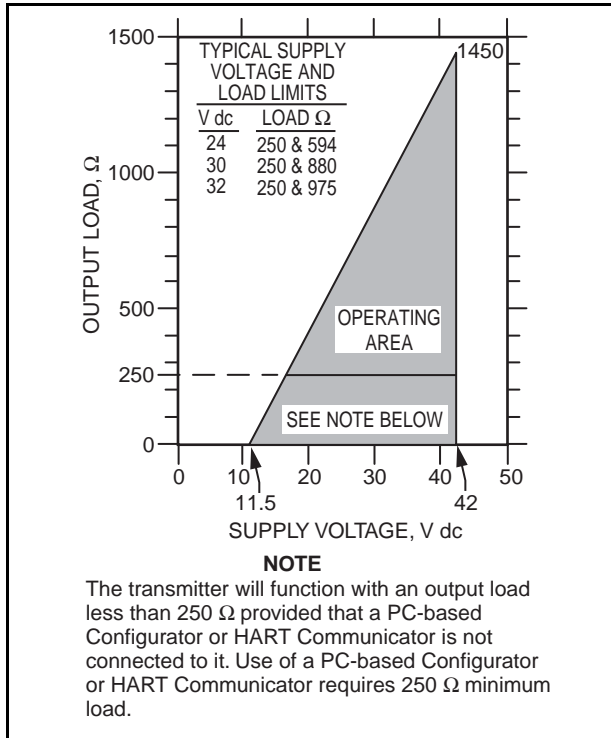

Current Outputs for Overage, Fail, and Offline Conditions - HART Only

Parameter	HART
OFFLINE	User configurable between 4 and 20 mA
SENSOR FAILURE	User configurable to Fail LO or Fail HI
FAIL LO	3.60 mA
UNDERRANGE	3.80 mA
OVERRANGE	20.50 mA
FAIL HI	21.00 mA

Write Protect Jumper

Can be positioned to lock out all configurators from making transmitter database changes. This makes transmitter suitable for Safety Shutdown System Applications that require this feature.

Configuration and Calibration Data, and Electronics Upgradeability

All factory characterization data, and user configuration and calibration data are stored in the sensor. This means that the electronics module can be replaced or changed from one type to another.

A module may be replaced without the need for reconfiguration or recalibration. Although module replacement can affect accuracy up to 0.20% of span, this error can be removed by an mA trim without application of pressure.

Changing module types may require reconfiguration and recalibration, as well as a different terminal block, if applicable, but all factory characterization data is retained.

HART (Version -T) Communications

4 to 20 mA Analog Mode

Output signal is updated 30 times per second. A minimum loop load of 250 ohms is required. See Table 1 for communication parameters.

Multidrop Mode (Fixed Current)

This mode supports communications with up to 15 transmitters on a single pair of signal/power wires. The output signal is updated 4 times per second. A minimum loop load of 250 ohms is required. See Table 1 for communication parameters.

FOUNDATION Fieldbus (Version -F) Communications

This serial, two-way communication system runs at 31.25 kbits/s. The digital output signal is superimposed on the dc power signal on the bus, and controlled by a strict cycle schedule and protocol. Supply voltage, 9 to 32 V dc, is by a specific Fieldbus power source. Current consumption is 19.5 mA. The maximum number of devices on a non-intrinsically safe bus is 32. For intrinsically safe bus systems, the maximum number is 5. See Table 1 for communication parameters.

Table 1. Communication Parameters - HART and FOUNDATION Fieldbus

Parameter	HART		Fieldbus
	Analog Mode	Multidrop Mode	Digital
Remote Configurator	HART Communicator or PC-based Configurator		I/A Series System, PC or Fieldbus Host
Communication Rate	1200 baud	1200 baud	31.25 kbits/s
Communication Distance	3050 m (10 000 ft)	1525 m (5000 ft)	1900 m (6235 ft) (a)

a. The total bus length including all spurs. Maximum spur length is 120 m (395 ft). For hybrid installations, the maximum IS spur length is dependent on the field barrier used. For intrinsically safe bus installations, maximum spur length is 30 m (98 ft).

Configuration Capability (See Note below)

Calibrated Range

- ▶ Input range within Span and Range Limits
- ▶ Pressure EGU (see Table 2)

Output Measurement #1 — Digital Primary Variable and 4 to 20 mA (HART Only)

- ▶ Mode: Linear
- ▶ Units: Same as calibrated range

Output Measurement #2 — Digital Secondary Variable

- ▶ Mode: Linear
- ▶ Units: A common pressure EGU
- ▶ Measurements #1 and #2: These measurements may be swapped

NOTE

Numerous parameters can be configured and/or displayed such as electronic damping, failsafe direction, transmitter location, calibration, tag data, etc. See applicable configuration instructions for details.

Table 2. Allowable Pressure Units for Calibrated Range

inH ₂ O	inHg	kPa	mbar	kg/cm ²
ftH ₂ O	mmHg	MPa	bar	psi
mmH ₂ O	Pa	torr	g/cm ²	atm

Optional LCD Indicator

Indicator provides:

- ▶ Two Lines; five numeric characters on top line (four when a minus sign is needed) and seven alphanumeric characters on bottom line
- ▶ Measurement Readout; value on top line and units label on bottom line
- ▶ Configuration and Calibration Prompts.

Two pushbuttons provide for:

- ▶ Configuration Functions
- ▶ Calibration Functions.

Figure 3. LCD Indicator with Pushbuttons

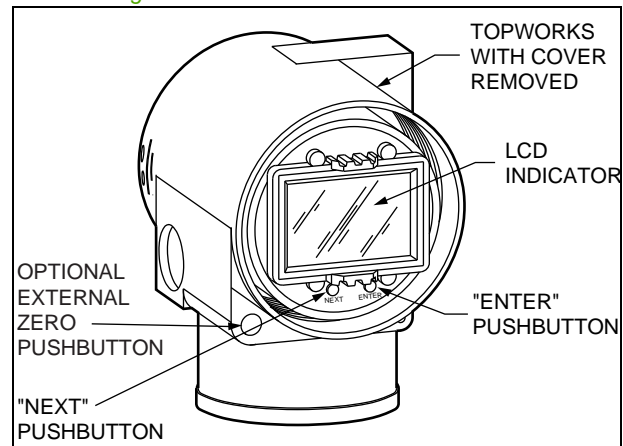

Optional External Zero Adjustment

An external pushbutton mechanism is isolated from the electronics compartment and magnetically activates an internal reed switch through the housing. This eliminates a potential leak path for moisture or contaminants to get into the electronics compartment. This external zero adjustment can be disabled by a configuration selection.

Optional Custom Configuration (Option -C2)

For the transmitter to be custom configured by the factory, the user must fill out a data form. If this option is not selected, a standard default configuration will be provided.

Parameter	Standard (Default) Configuration	Example of Custom Configuration Option -C2
Measurement 1	Linear	Linear
Device Name	DevNam	FT103A
External Zero	Enabled	Disabled
EGU	%	inH ₂ O
Damping	None	0.5 s

Functional Block Diagrams

Refer to Figures 4 through 7.

Figure 4. HART 4 to 20 mA Topology

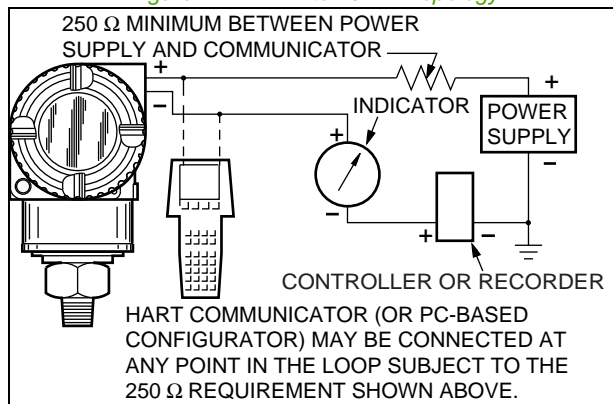

Figure 5. Fieldbus Miscellaneous Topologies

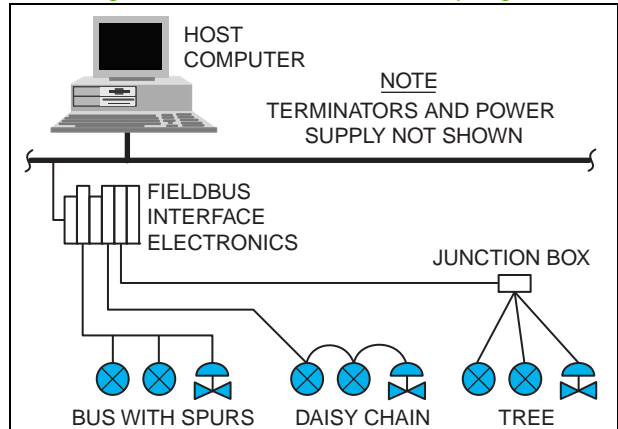

Figure 6. HART Multidrop Topology

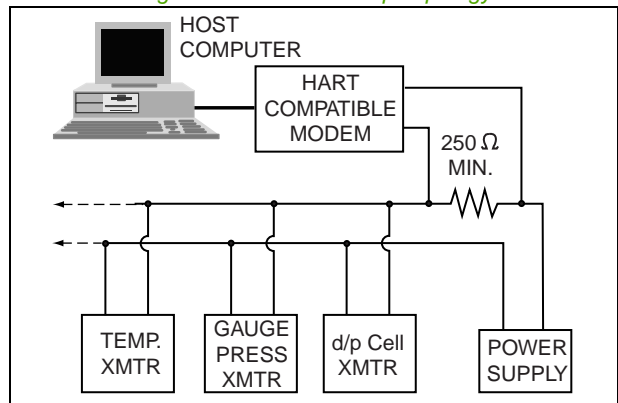
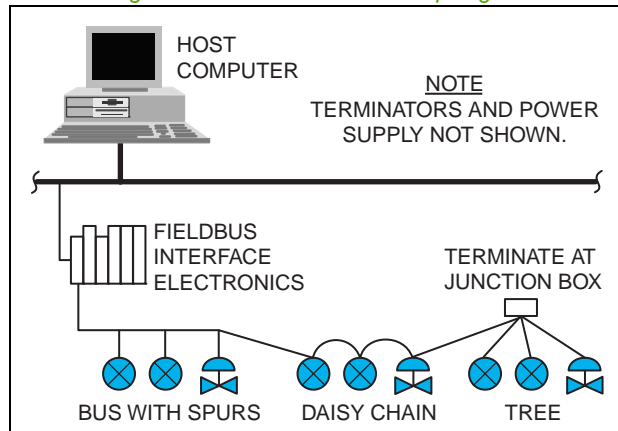

Figure 7. Fieldbus with Mixed Topologies



OPERATING, STORAGE, AND TRANSPORTATION CONDITIONS

Influence	Reference Operating Conditions	Normal Operating Conditions (a)	Operative Limits (a)	Storage and Transportation/ Limits
Process Connection Temp. ▶ w/Silicone Fill Fluid ▶ w/Fluorinert Fill Fluid	▶ 24 ± 2°C (75 ± 3°F) ▶ 24 ± 2°C (75 ± 3°F)	▶ -29 to + 82°C (-20 to +180°F) ▶ -29 to + 82°C (-20 to +180°F)	▶ -46 and +121°C (b) (-50 and +250°F) (b) ▶ -29 and +121°C (-20 and +250°F)	▶ Not Applicable ▶ Not Applicable
Electronics Temperature (b) ▶ with LCD Indicator (c)	▶ 24 ± 2°C (75 ± 3°F) ▶ 24 ± 2°C (75 ± 3°F)	▶ -29 to + 82°C (d) (-20 to +180°F) (d) ▶ -20 to + 82°C (d) (-4 to +180°F) (d)	▶ -40 and +85°C (d) (-40 and +185°F) (d) ▶ -29 and +85°C (d) (-20 and +185°F) (d)	▶ -54 and +85°C (-65 and +185°F) ▶ -54 and +85°C (-65 and +185°F)
Relative Humidity (e)	50 ±10%	0 to 100%	0 and 100%	0 and 100% (e) Noncondensing
Supply Voltage – mA Output HART	30 ±0.5 V dc	11.5 to 42 V dc (f)	11.5 and 42 V dc (f)	Not Applicable
Output Load – mA Output HART	650 Ω (see Figure 4)	0 to 1450 Ω (g)	0 and 1450 Ω (g)	Not Applicable
Supply Voltage FOUNDATION Fieldbus	30 ±0.5 V dc	9 to 32 V dc (h)	9 and 32 V dc (h)	Not Applicable
Vibration	1 m/s ² (0.1 “g”)	6.3 mm (0.25 in) Double Amplitude: from 5 to 15 Hz with Aluminum Housing from 5 to 9 Hz with 316 ss Housing 0 to 30 m/s ² (0 to 3 “g”) from 15 to 500 Hz with Aluminum Housing; 0 to 10 m/s ² (0 to 1 “g”) from 9 to 500 Hz with 316 ss Housing	11 m/s ² (1.1 “g”) from 2.5 to 5 Hz (in Shipping Package)	
Mounting Position	Upright or Horizontal	Upright or Horizontal	No Limit	Not Applicable

- a. Normal Operating Conditions and Operative Limits are defined per ANSI/ISA 51.1-1979 (R1993).
- b. Selection of Option -J extends the low temperature operative limit of transmitters with silicone filled sensors down to -50°C (-58°F). Performance is not assured below -29°C. Sensor damage may occur if process is frozen.
- c. The optional LCD will not be damaged at any temperature within the “Storage and Transportation Limits”; however, updates will be slowed and readability decreased at temperatures outside the “Normal Operating Conditions”.
- d. Refer to the Electrical Safety Specifications section for a restriction in ambient temperature with certain electrical certifications.
- e. With topworks cover on and conduit entrances sealed. Also noncondensing during transportation and storage.
- f. 11.5 V dc can be reduced to 11 V dc by using the plug-in shorting bar that is offered. See Physical Specifications section.
- g. With HART, 250 Ω minimum load required for proper communication.
- h. Power supplied by a specific Fieldbus power supply.

PERFORMANCE SPECIFICATIONS

Zero-Based Calibrations; 316L ss Diaphragm with Silicone Fluid; Under Reference Operating Conditions unless otherwise Specified; URL = Upper Range Limit, and Span = Calibrated Span.

Accuracy (Includes Linearity, Hysteresis, and Repeatability)

Accuracy, % of Span (a)	
Spans ≥10% URL	Spans <10% URL
±0.025%	±[0.021 + 0.0004 (URL/Span)]%

a. Applies to HART (4 to 20 mA or digital) and FOUNDATION Fieldbus.

Stability

Long term drift is ±0.15% of URL for 10 years (reference conditions).

Calibration Frequency

The calibration frequency is five years. The five years is derived using the values of allowable error (% span), TPE (% span), performance margin (% span), and stability (% span/month); where:

$$\text{Calibration Frequency} = \frac{\text{Performance Margin}}{\text{Stability}} = \text{Months}$$

Power-Up Time

Less than 5 seconds for output to reach first valid measurement.

Vibration Effect

Total effect is ±0.2% of URL per “g” for vibrations in the frequency range of 5 to 500 Hz; with double amplitudes of 6.3 mm (0.25 in) in the range of 5 to 15 Hz, or accelerations of 3 “g” in the range of 15 to 500 Hz, whichever is smaller, for transmitters with aluminum housings; and with double amplitudes of 6.3 mm (0.25 in) in the range of 5 to 9 Hz, or accelerations of 1 “g” in the range of 9 to 500 Hz, whichever is smaller, for transmitters with 316 ss housings.

Supply Voltage Effect

The output changes less than 0.005% of span for each 1 V change within the specified supply voltage requirements.

RFI Effect

The output error is less than 0.1% of span for radio frequencies in the range of 27 to 1000 MHz and field intensity of 30 V/m when the transmitter is properly installed with shielded cable in conduit and earthing (grounding), and housing covers are in place. (Per IEC Std. 61000-4-3.)

Position Effect

The transmitter may be mounted in any position. Any zero effect caused by the mounting position can be eliminated by rezeroing. There is no span effect.

Ambient Temperature Effect

Total effect for a 28°C (50°F) change within Normal Operating Condition limits is:

$$\pm(0.015\% \text{ URL} + 0.030\% \text{ Span})$$

Switching and Indirect Lightning Transients

The transmitter can withstand a transient surge up to 2000 V common mode or 1000 V normal mode without permanent damage. The output shift is less than 1.0%. (Per ANSI/IEEE C62.41-1980 and IEC Std. 61000-4-5.)

PHYSICAL SPECIFICATIONS

Environmental Protection

The enclosure has the dusttight and weatherproof rating of IP66 as defined by IEC 60529, and provides the environmental and corrosion resistant protection rating of NEMA 4X.

Process Wetted Materials (High Pressure Side)

Industry Standard 316L ss for process connection and sensor diaphragm

Reference Side Materials (Atmospheric Side)

Silicon, Pyrex, RTV, and 316 ss

Sensor Fill Fluids

Silicone Oil

Electronics Housing and Housing Covers

Housing has two compartments to separate the electronics from the field connections. The housing and covers are made from low copper (0.6% maximum) die-cast aluminum alloy with an epoxy finish, or from 316 ss. Buna-N O-ring seals are used to seal the threaded housing covers, housing neck, and terminal block.

Electronics Module

Printed wiring assemblies are conformally coated for moisture and dust protection.

Mounting Position

The transmitter may be mounted in any orientation.

Electrical Connections

Field wires enter through 1/2 NPT, PG 13.5 or M20 threaded entrances on either side of the electronics housing. Wires terminate under screw terminals and washers on terminal block in the field terminal compartment (see Figure 8). Unused entrance is plugged to insure moisture and RFI/EMI protection.

Approximate Mass

- ▶ 1.5 kg (3.3 lb) with Aluminum Housing
- ▶ Add 1.1 kg (2.4 lb) with 316 ss Housing
- ▶ Add 0.2 kg (0.4 lb) with LCD Indicator Option

Dimensions

See “Dimensions – Nominal” section and Dimensional Print DP 020-447.

Figure 8. Field Terminals Compartment for HART and Fieldbus

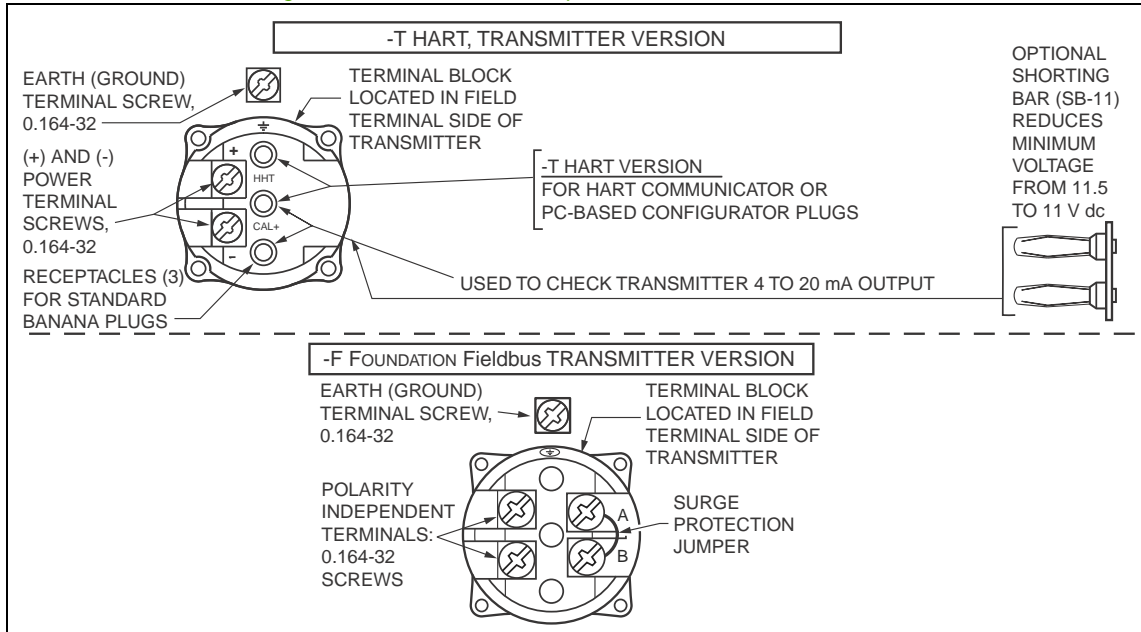

ELECTRICAL SAFETY SPECIFICATIONS

The transmitter has been designed to meet the Electrical Safety Specifications listed in the tables that follow. Contact Global Customer Support for information or status of testing laboratory approvals or certifications.

With Electrical Safety Design Codes M and P, the user must permanently mark (check off on rectangular box on data plate) one type of protection only (ia and ib, d, or n). Do not change this mark once it has been applied.

When selecting Safety Design Code W (for HART only), the user must permanently mark (check off in rectangular block on data plate) intrinsically safe certifications for ATEX, CSA, or FM, as applicable. Do not change this mark once it has been applied.

Electronic Version -T, HART

Testing Laboratory, Types of Protection, and Area Classification	Application Conditions	Elec. Safety Design Code
ATEX intrinsically safe; II 1 GD, EEx ia IIC, Zone 0, or II 1/2 GD EEx ib IIC, Zone 0/Zone 1.	Temperature Class T4; Ta = -40 to +80°C Temperature Class T5; Ta = -40 to +40°C Temperature Class T6; Ta = -40 to +40°C	E
ATEX flameproof; II 2 GD, EEx d IIC, Zone 1.	Temperature Class T6, 85°C; Ta = -40 to +80°C.	D
ATEX protection n; II 3 GD, EEx nL IIC, Zone 2.	Temperature Class T4; Ta = -40 to +80°C Temperature Class T5; Ta = -40 to +70°C Temperature Class T6; Ta = -40 to +40°C	N

Electronic Version -T, HART (Continued)

Testing Laboratory, Types of Protection, and Area Classification	Application Conditions	Elec. Safety Design Code
ATEX multiple certifications, ia & ib, and n. Refer to Codes E and N for details.	Applies to Codes E and N, but not to Code D. Note 2.	M
ATEX multiple certifications, ia & ib, d, and n. Refer to Codes D, E and N for details.	Applies to Codes D, E, and N. Note 2.	P
CSA intrinsically safe for Class I, Div. 1, Groups A, B, C, and D, Class II, Div. 1, Groups E, F, and G, and Class III, Div. 1.	Connect per MI 020-427. Temperature Class T6 at 40°C, and T3C at 85°C maximum ambient.	C
CSA zone certified intrinsically safe Ex ia IIC, and energy limited Ex nA II.	Temperature Class T4 at 40°C, and T3 at 85°C maximum ambient.	C
CSA explosionproof for Class I, Div. 1, Groups B, C, and D; dust-ignitionproof for Class II, Div. 1, Groups E, F, and G; and Class III, Div. 1.	Maximum Ambient Temperature 85°C.	C
CSA for Class I, Div. 2, Groups A, B, C, and D; Class II, Div. 2, Groups F and G; Class III, Div. 2.	Temperature Class T6 at 40°C and T4A at 85°C maximum ambient.	C
CSA field device zone certified flameproof Ex d IIC. Also, all certifications of Code C above.	Maximum Ambient Temperature 85°C.	B
FM intrinsically safe for Class I, Div. 1, Groups A, B, C, and D; Class II, Div. 1, Groups E, F, and G; and Class III, Div. 1.	Connect per MI 020-427. Temperature Class T4A at 40°C and T4 at 85°C maximum ambient.	F
FM zone certified intrinsically safe AEx ia IIC.	Temperature Class T4 at 85°C maximum ambient.	F
FM explosionproof for Class I, Div. 1, Groups B, C, and D; dust-ignitionproof for Class II, Div. 1, Groups E, F, and G; and Class III, Div. 1.	Temperature Class T6 at 80°C and T5 at 85°C maximum ambient.	F
FM nonincendive Class I, Div. 2, Groups A, B, C, and D; Class II, Div. 2, Groups F and G; and Class III, Div. 2.	Temperature Class T4A at 40°C and T4 at 85°C maximum ambient.	F
FM field device zone certified flameproof AEx d IIC. Also, all certifications of Code F above.	Temperature Class T6 at 75°C maximum ambient.	G
IECEx flameproof, Ex d IIC.	Temperature Class T6; Ta = -40 to +75°C.	V
SAA intrinsically safe, Ex ia IIC, Gas Group IIC, Zone 0.	Temperature Class T4 at 85°C maximum ambient.	H
SAA nonincendive, Ex n IIC, Gas Group IIC, Zone 2.	Temperature Class T6.	K
Multi-marked as follows: CSA intrinsically safe, Cl. I, Div. 1, Groups A, B, C, D; Class II, Div. 1, Groups E, F, G; Class III, Div. 1; also CSA zone certified intrinsically safe Ex ia IIC. FM intrinsically safe, Cl. I, Div. 1, Groups A, B, C, D; Class II, Div. 1, Groups E, F, G; Class III, Div. 1. Also FM zone certified intrinsically safe AEx ia IIC. ATEX intrinsically safe, II 1 GD, EEx ia IIC, Zone 0.	See application conditions for Code C intrinsically safe applications. See application conditions for Code F intrinsically safe applications. See application conditions for Code E intrinsically safe applications.	W

Electronic Version -F, FOUNDATION Fieldbus

Testing Laboratory, Types of Protection, and Area Classification	Application Conditions	Elec. Safety Design Code
ATEX FISCO field device intrinsically safe; II 1 G, EEx ia IIC, Zone 0.	Temperature Class T4; Ta = -40 to +80°C.	E
ATEX flameproof; II 2 GD, EEx d IIC, Zone 1.	Temperature Class T6, 85°C; Ta = -40 to +80°C.	D
ATEX FNICO field device protection n: II 3 G EEx nL IIC, Zone 2.	Temperature Class T4; Ta = -40 to +80°C.	N
CSA FISCO field device intrinsically safe for Class I, Division 1, Groups A, B, C, and D; Class II, Division 1, Groups E, F, and G; Class III, Division 1. Also zone certified intrinsically safe Ex ia IIC, and energy limited Ex nA II.	Temperature Class T6 at 40°C, and T4A at 85°C maximum ambient. Temperature Class T4 at 40°C, and T3 at 85°C maximum ambient.	C
CSA explosionproof for Class I, Division 1, Groups B, C, and D; and dust-ignitionproof for Class II, Division 1, Groups E, F, and G; and Class III, Division 1.	Maximum Ambient Temperature 85°C.	C
CSA FNICO field device Class I, Division 2, Groups A, B, C, and D; Class II, Division 2, Groups F and G; and Class III, Division 2.	Temperature Class T6 at 40°C and T4A at 85°C maximum ambient.	C
CSA field device zone certified flameproof Ex d IIC. Also, all certifications of Code C above.	Maximum Ambient Temperature 85°C.	B
FM FISCO field device intrinsically safe for Class I, Division 1, Groups A, B, C, and D; Class II, Division 1, Groups E, F, and G; Class III, Division 1. Also zone approved intrinsically safe AEx ia IIC.	Temperature Class T4A at 40°C and T4 at 85°C maximum ambient. Temperature Class T4 at 85°C maximum ambient.	F
FM FNICO field device nonincendive Class I, Division 2, Groups A, B, C, and D; Class II, Division 2, Groups F and G, and Class III, Division 2.	Temperature Class T4A at 40°C and T4 at 85°C maximum ambient.	F
FM explosionproof for Class I, Div. 1, Groups B, C, and D; dust-ignitionproof for Class II, Div. 1, Groups E, F, and G; and Class III, Div. 1.	Temperature Class T6 at 80°C and T5 at 85°C maximum ambient.	F
FM field device zone certified flameproof AEx d IIC. Also, all certifications of Code F above.	Temperature Class T6 at 75°C maximum ambient.	G
IECEx FISCO field device intrinsically safe; Ex ia IIC, Zone 0.	Temperature Class T4; Ta = -40 to +80°C.	T
IECEx flameproof, Ex d IIC.	Temperature Class T6; Ta = -40 to +75°C.	V
IECEx FNICO field device protection n: Ex nL IIC, Zone 2.	Temperature Class T4; Ta = -40 to +80°C.	U

MODEL CODE

Description	Model												
I/A Series, Premium Performance, Direct Connected Gauge Pressure Transmitter	IGP50												
Electronic Versions and Output Signal													
Intelligent; Digital HART and 4 to 20 mA dc (Version -T)	-T												
Intelligent; Digital FOUNDATION Fieldbus (Version -F)	-F												
Structure Code - Select from one of the following two groups:													
1. Transmitter													
<table border="0"> <tr> <td>Process Connection</td> <td>Sensor</td> <td>Sensor Fill Fluid</td> <td>Connection Type</td> <td></td> </tr> <tr> <td>316L ss</td> <td>316L ss</td> <td>Silicone</td> <td>1/2 NPT External Thread, 1/4 NPT Internal Thread</td> <td>22</td> </tr> </table>	Process Connection	Sensor	Sensor Fill Fluid	Connection Type		316L ss	316L ss	Silicone	1/2 NPT External Thread, 1/4 NPT Internal Thread	22	22		
Process Connection	Sensor	Sensor Fill Fluid	Connection Type										
316L ss	316L ss	Silicone	1/2 NPT External Thread, 1/4 NPT Internal Thread	22									
2. Flameproof Transmitter													
<table border="0"> <tr> <td>Process Connection</td> <td>Sensor</td> <td>Sensor Fill Fluid</td> <td>Connection Type</td> <td></td> </tr> <tr> <td>316L ss</td> <td>316L ss</td> <td>Silicone</td> <td>1/2 NPT External Thread, 1/4 NPT Internal Thread</td> <td>52</td> </tr> </table>	Process Connection	Sensor	Sensor Fill Fluid	Connection Type		316L ss	316L ss	Silicone	1/2 NPT External Thread, 1/4 NPT Internal Thread	52	52		
Process Connection	Sensor	Sensor Fill Fluid	Connection Type										
316L ss	316L ss	Silicone	1/2 NPT External Thread, 1/4 NPT Internal Thread	52									
Span Limits													
<table border="0"> <tr> <td>MPa</td> <td>psi</td> <td>bar</td> <td></td> </tr> <tr> <td>0.017 and 1.4</td> <td>2.5 and 200</td> <td>0.17 and 14</td> <td>D</td> </tr> <tr> <td>0.17 and 14</td> <td>25 and 2000</td> <td>1.7 and 140</td> <td>E</td> </tr> </table>	MPa	psi	bar		0.017 and 1.4	2.5 and 200	0.17 and 14	D	0.17 and 14	25 and 2000	1.7 and 140	E	D E
MPa	psi	bar											
0.017 and 1.4	2.5 and 200	0.17 and 14	D										
0.17 and 14	25 and 2000	1.7 and 140	E										
Conduit Connection and Housing Material													
1/2 NPT Conduit Connection, Aluminum Housing	1												
PG 13.5 Conduit Connection, Aluminum Housing (With Electrical Safety Codes E, D, M, N, and P only)	2												
1/2 NPT Conduit Connection, 316 ss Housing	3												
PG 13.5 Conduit Connection, 316 ss Housing (With Electrical Safety Codes E, D, M, N, and P only)	4												
M20 Conduit Connection, Both Sides, Aluminum Housing (With Electrical Safety Codes E, D, M, N, and P only)	5												
M20 Conduit Connection, Both Sides, 316 ss Housing (With Electrical Safety Codes E, D, M, N, and P only)	6												

MODEL CODE

MODEL CODE (CONTINUED)

Description (Continued)	Model
Electrical Safety (Also see Electrical Safety Specifications Section)	
ATEX II 1 GD, EEx ia IIC, Zone 0; or II 1/2 GD, EEx ib IIC, Zone 0/1 (Versions D and T only)	E
ATEX FISCO, II 1 G, EEx ia IIC, Zone 0 (Version F only)	E
ATEX II 2 GD, EEx d IIC, Zone 1 (a)	D
ATEX II 3 GD, EEx nL IIC, Zone 2 (Versions D and T only)	N
ATEX FNICO, II 3 G, EEx nL IIC, Zone 2 (Version F only)	N
ATEX Multiple Certifications (includes ATEX Codes E and N) (Versions D and T only)	M
(See Electrical Safety Specifications section for <u>user marking</u>)	
ATEX Multiple Certifications (includes ATEX Codes E, D, and N) (Versions D and T only) (a)	P
(See Electrical Safety Specifications section for <u>user marking</u>)	
CSA Certifications (with Conduit Connection Codes 1 and 3 only): (b)	C
Intrinsically Safe, Division 1, Classes I, II, and III (Versions D and T only)	
Zone Certified intrinsically safe, Ex ia IIC, and energy limited Ex nA II (Version T only)	
Explosionproof and dust-ignitionproof, Division I, Classes I, II, and III (All Versions)	
For Division 2, Classes I, II, and III (Versions D and T only)	
FISCO, intrinsically safe, Division 1, Classes I, II, and III (Version F only)	
FNICO, Division 2, Classes I, II, and III (Version F only)	
CSA Certifications (with Conduit Connection Codes 1 and 3 only): (a)	B
Zone certified flameproof, Ex d IIC. Also all certifications of Code C above (All Versions)	
FM Approvals (with Conduit Connection Codes 1 and 3 only): (b)	F
Intrinsically Safe, Division 1, Classes I, II, and III (Versions D and T only)	
Zone approved intrinsically safe, AEx ia IIC (Version T only)	
Explosionproof and dust-ignitionproof, Division I, Classes I, II, and III (All Versions)	
Nonincendive, Division 2, Classes I, II, and III (Versions D and T only)	
FISCO, intrinsically safe, Division 1, Classes I, II, and III (Version F only)	
FNICO, nonincendive, Division 2 (Version F only)	
FM Approvals (with Conduit Connection Codes 1 and 3 only): (a)	G
Zone approved flameproof, AEx d IIC. Also all certifications of Code F above (All Versions).	
IECEx FISCO, Ex ia IIC, Zone 0; Version F only	T
IECEx flameproof, Ex d IIC; All Versions	V
IECEx FNICO, Ex nL IIC, Zone 2; Version F only	U
SAA intrinsically safe, Ex ia IIC, Zone 0. (Version T only)	H
SAA nonincendive, Ex n IIC, Zone 2. (Version T only)	K
Multi-marked for ATEX, CSA, and FM Intrinsically Safe Applications (Version -T only) (c)	W
Optional Selections	
Mounting Bracket Set	
Painted Steel Bracket with Plated Steel Bolts, 1/2 NPT (with Conduit Connection Codes 1 and 3 only)	-M1
Stainless Steel Bracket with Stainless Steel Bolts, 1/2 NPT (with Conduit Connection Codes 1 and 3 only)	-M2
Painted Steel Bracket with Plated Steel Bolts, PG 13.5 (with Conduit Connection Codes 2 and 4 only)	-M3
Stainless Steel Bracket with Stainless Steel Bolts, PG 13.5 (with Conduit Connection Codes 2 and 4 only)	-M4
Painted Steel Bracket with Plated Steel Bolts, M20 (with Conduit Connection Codes 5 and 6 only)	-M5
Stainless Steel Bracket with Stainless Steel Bolts, M20 (with Conduit Connection Codes 5 and 6 only)	-M6
Digital Indicator with Pushbuttons	
Digital Indicator, Pushbuttons, and Window Cover	-L1
Vent Screw and Block & Bleed Valve	
Block and Bleed Valve, Carbon Steel (Not with Option -X1)	-V2
Block and Bleed Valve, 316 ss (Not with Option -X1)	-V3
Block and Bleed Valve, 316 ss w/Monel® Trim (Not with Option -X1)	-V4

MODEL CODE (CONTINUED)

Description (Continued)	Model
Conduit Thread Adapters	
Hawke-Type 1/2 NPT Cable Gland for use with Conduit Connection Codes 1 and 3 only (d)	-A1
Plastic PG 13.5 Cable Gland for use with Conduit Connection Codes 2 and 4 only (e)	-A2
M20 Connector for use with Conduit Connection Codes 1 and 3 only (d)	-A3
Brass PG 13.5 Cable Gland (Trumpet-Shaped) for use with Conduit Connection Codes 2 and 4 only (e)	-A4
Electronics Housing Features	
External Zero Adjustment	-Z1
Custody Transfer Lock and Seal	-Z2
External Zero Adjustment and Custody Transfer Lock and Seal	-Z3
Custom Factory Configuration	
Digital Output (4 to 20 mA default if not selected)	-C1
Full Factory Configuration (Requires Configuration Form to be filled out)	-C2
Cleaning and Preparation	
Unit Degreased - for Silicone Filled Sensors Only Not for Oxygen/Chlorine Service, or Options -V2 to -V4	-X1
Instruction Books (Common MI, Brochure, and Full Documentation Set on DVD is Standard)	
Without Instruction Book and DVD - Only "Getting Started" Brochure is supplied	-K1
Miscellaneous Optional Selections	
Low Temperature Operative Limit of Electronics Housing Extended Down to -50°C (-58°F) (f)	-J
R 1/2 Process Connection (1/2 NPT to R 1/2 Adapter)	-R
Supplemental Customer Tag (Stainless Steel Tag wired onto Transmitter)	-T
Seventeen Year Warranty (g)	-W
Example: IGP50-T22E1F-M2L1C2X1T	

- a. Only available with flameproof transmitter Structure Code 52.
- b. Not available with flameproof transmitter Structure Code 52.
- c. For multi-marking details, see Electrical Safety Specifications section.
- d. Available with Electrical Safety Codes E, D, M, and N only.
- e. Available with Electrical Safety Code E only
- f. -50°C indicates sensor and electronics ambient temperature capabilities. Performance is not assured below -29°C. Sensor damage may occur if process is frozen.
- g. Standard Warranty is five years.

SUGGESTED RFQ SPECIFICATIONS

The manufacturer shall provide premium performance, direct connected pressure transmitters featuring HART or FOUNDATION Fieldbus Communication Protocol. They shall provide remote digital communications capability for measuring gauge pressure and transmit a digital or 4 to 20 mA (HART only) output signal for use in a standard two-wire dc supply voltage system. The specifications for these transmitters are as follows:

Communication Protocol:	HART: Digital and/or 4 to 20 mA dc output signal FOUNDATION Fieldbus: Digital output signal
Remote Communications:	Must not interfere with output.
Digital Accuracy:	±0.025% of calibrated span for spans ≥10% of URL.
Damping:	Settable for a range of none to 32 seconds.
RFI Protection:	0.1% error between 27 and 1000 MHz at 30 V/m field intensity
Proof Pressure:	710 or 7100 psi, depending on sensor selected.
Span Limits:	From 2.5 to 2000 psi using only two sensors.
Electronics Housing:	316 ss, or Aluminum housing with Epoxy finish
Modular Electronics:	Enclosed in a NEMA 4X/IP66 rated housing sealed with O-rings for double protection against moisture or other contaminants. Optional integral LCD Digital Indicator with on-board configuration pushbuttons.
Mounting:	Direct to process or bracket mounted to pipe or surface.
Process Connection:	Direct Connected Transmitter: Direct to process piping with 1/2 NPT or optional R 1/2 or G 1/2 B external threads. Internal 1/4 NPT thread also provided as plumbing connection to process.
Sensor Material:	Industry standard 316L ss.
Electrical Classification:	Nonincendive for Class I and Class II, Division 2 locations; intrinsically safe or explosionproof for Class I and Class II, Division 1 locations. Versions available to meet Agency flameproof and zone requirements. Comply with applicable European Union Directives.
Approximate Mass:	Direct Connected Transmitter: 1.5 kg (3.3 lb) With 316 ss Electronics Housing: Add 1.1 kg (2.4 lb) With Optional LCD Indicator: Add 0.2 kg (0.4 lb)
Model:	Foxboro I/A Series Premium Performance Model IGP50 Direct Connected Gauge Pressure Transmitter; with HART or FOUNDATION Fieldbus Communication Protocol; or equivalent.

DIMENSIONS – NOMINAL

$\frac{\text{mm}}{\text{in}}$

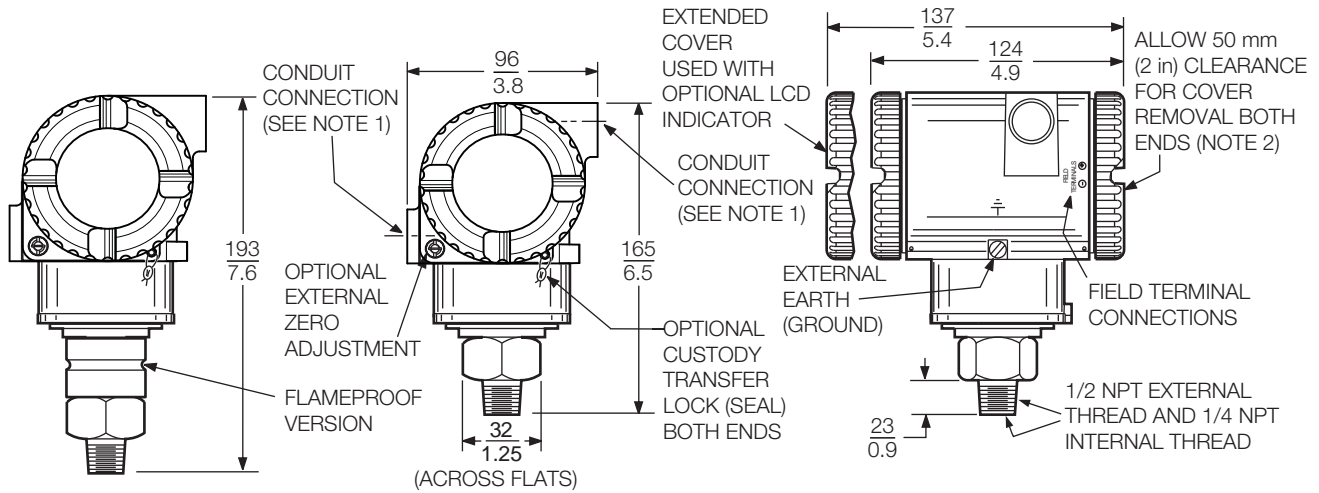

NOTES

1. CONDUIT CONNECTION 1/2 NPT OR PG 13.5, BOTH SIDES: PLUG UNUSED CONNECTION WITH METAL PLUG (SUPPLIED).
2. TOPWORKS ROTATABLE TO ANY POSITION WITHIN ONE TURN COUNTERCLOCKWISE OF FULLY TIGHTENED POSITION.
3. DO NOT USE 1/4 NPT INTERNAL THREAD TO DIRECT-CONNECT THE TRANSMITTER TO PROCESS.

$\frac{\text{mm}}{\text{in}}$

OPTIONS -M1 TO -M6

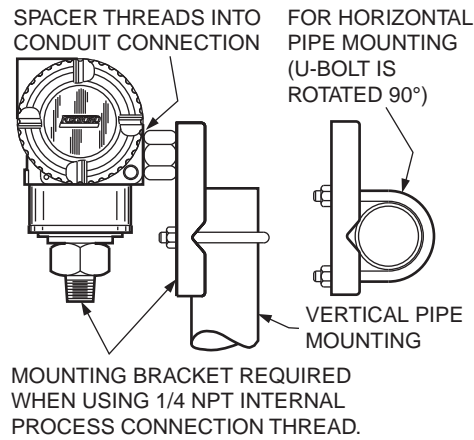

OPTION -R

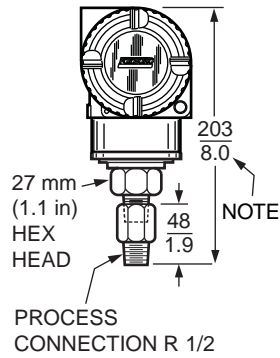

OPTIONS -V2, -V3, AND -V4

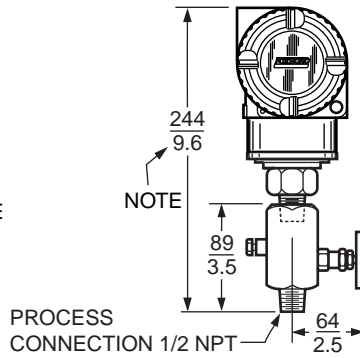

NOTES

1. FOR FLAMEPROOF TRANSMITTERS, ADD 28 mm (1.1in) TO OVERALL HEIGHT DIMENSION.
2. REFER TO DIMENSIONAL PRINT DP 020-447 FOR FURTHER INFORMATION.

ORDERING INSTRUCTIONS

1. Model Number.
2. Calibrated Pressure Range (using Allowable Pressure Units from the table below).

inH ₂ O	inHg	kPa	mbar	kg/cm ²
ftH ₂ O	mmHg	MPa	bar	psia
mmH ₂ O	Pa	torr	g/cm ²	atm

3. Configuration Data Form when Factory Calibration Option -C2 is specified.
4. Options and Accessories not in Model Code (see PSS 2A-1Z9 E).
5. User Tag Data – Data Plate; 32 characters maximum. For additional tag data, specify Optional Supplemental Tag -T.
6. User Tag Data – Software (Database):
 - ▶ HART, -T; 8 characters maximum
 - ▶ Fieldbus, -F; 32 characters maximum.

OTHER FOXBORO PRODUCTS

The Foxboro product lines offer a broad range of measurement and instrument products, including solutions for pressure, flow, analytical, temperature, positioning, controlling, and recording. For a list of these offerings, visit our web site at:

www.fielddevices.foxboro.com