

Model IGP25 I/A Series[®] Multirange Gauge Pressure Transmitter for Sanitary Processes with Digital or Analog Output Signals



The Foxboro[®] brand I/A Series Model IGP25 Gauge Pressure Transmitter with integral sanitary process connections is an intelligent, multirange, two-wire transmitter that provides precise, reliable measurement of gauge pressure, providing the measurement range and performance of “two transmitters in one.” It transmits a 4 to 20 mA or digital output signal using HART[®] or FOUNDATION[™] Fieldbus communication protocol for remote configuration, calibration, and monitoring. This transmitter has been specifically designed for use in sanitary processes.

FEATURES

- ▶ Integral Tri-Clamp type, mini tank spud, and extended mini tank spud integral sanitary process connectors.
- ▶ Conforms to 3-A sanitary standards.
- ▶ Multirange transmitters simplify planning, ordering, and spares procurement and stocking.
- ▶ Digital precision, stability, and resolution ensure top measurement performance.
- ▶ Characterized with integral process connection for improved performance.
- ▶ NEOBEE M-20 fill fluid.
- ▶ Code D sensor with a 400:1 turndown used for most sanitary processes; a Code E sensor is also offered for higher pressures, or rating of the Tri-Clamp used, whichever is less.
- ▶ Fieldbus versions FISCO/FNICO compliant.
- ▶ 316L ss and nickel alloy⁽¹⁾ diaphragm materials.
- ▶ Standard 32 Ra seal surface finish, optional 15 Ra surface finish also offered.
- ▶ Local configuration available with the optional LCD Indicator with on-board pushbuttons.

1. Equivalent to Hastelloy[®] C-276. Hastelloy is a registered trademark of Haynes International, Inc.

- ▶ Dual Seal Certified by CSA to meet ANSI/ISA 12.2701-2003 requirements.
- ▶ Multi-marking is available for HART electronic versions for FM, CSA, and ATEX intrinsically safe installations. The user determines and permanently marks on the data plate the certification to be applied.
- ▶ Durable aluminum or 316 ss housing available; both meet NEMA 4X and IP66 ratings.
- ▶ Complies with NAMUR NE 21 Interference Immunity requirement, and NAMUR NE 43 analog output overrange and underrange annunciations.
- ▶ CE marked; complies with applicable EMC, ATEX, and PED European Union Directives.
- ▶ Complies with EMC Directive 89/336/EEC by conforming to following EN and IEC standards: EN 61326-1, and IEC 61000-4-2 through 61000-4-6.
- ▶ Designed for hazardous areas. Versions available to meet agency zone requirements.
- ▶ Numerous options and accessories offered.
- ▶ Standard 5-year warranty; 17-year optional.

I/A Series PRESSURE TRANSMITTER FAMILY

The I/A Series Electronic Pressure Transmitters are a complete family of d/p Cell[®], gauge, absolute, multirange, multivariable, and premium performance transmitters, as well as transmitters with remote or direct mount pressure seals, all using field-proven silicon strain gauge sensors and common topworks.

Select the electronics module you need to provide just the right level of intelligence for your application and budget. If your needs change, the modular design allows easy migration to standards including HART and FOUNDATION Fieldbus.

TRUE MULTIRANGE CAPABILITY

Excellent performance is maintained over a very wide turndown range. The transmitter provides not only the functionality of two transmitters in one, but also the performance that could previously be attained only by selecting one of several different sensors.

MULTIRANGE FUNCTIONALITY

The turndown ratio for span adjustment is 400:1. The IGP25 with its 1400 kPa (200 psi) URL sensor can be set to provide a 4 to 20 mA output for any range between 0 to 3.5 and 0 to 1400 kPa (0 to 0.5 and 0 to 200 psi). This means that one sensor covers the ranges normally requiring two separate transmitters.

MULTIRANGE PERFORMANCE

The IGP25 can be considered a true multirange transmitter because its performance is maintained over a very wide turndown range, meaning that it performs as well as two separate transmitters designed to cover the same turndown range.

Accuracy of $\pm 0.10\%$ of span is maintained for a turndown range of 120:1. Achieving this performance with conventional transmitters would require, for example, use of both a 1400 kPa (200 psi) URL transmitter and a 200 kPa (30 psi) URL transmitter (with accuracy maintained over nearly a 20:1 turndown ratio), rather than a single 1400 kPa (200 psi) "multirange" transmitter.

SANITARY PROCESS CONNECTORS

All welded, integral, 316L stainless steel process connector with either Tri-Clamp type or tank spud sanitary process connection.

Flush Tri-clamp type connections offered in 1 1/2-, 2-, and 3-in sizes with either a 316L ss or nickel alloy⁽²⁾ diaphragm; and mini tank spud connections are offered with a 1 1/2-, 6-, or 9-in extension with a 316L ss diaphragm.

2. Equivalent to Hastelloy[®] C-276.

ELECTRONIC VERSIONS

Electronic versions include transmitters with HART and FOUNDATION fieldbus communication protocols. Fieldbus versions are FISCO/FNICO compliant as described in the Electrical Safety Specifications section.

DEPENDABLE AND EFFICIENT DESIGN

Simple, elegant packaging uses a minimum of parts to achieve exceptionally high reliability.

DIRECT PROCESS MOUNTING

Because of their light weight, these transmitters can be directly connected to the process piping or tank spud without mounting brackets.

EASE OF INSTALLATION

Rotatable Topworks allows transmitter installation in tight places, allows indicator to be positioned in preferred direction, and eases field retrofit.

Two Conduit Entrances offer a choice of entry positions for ease of installation and self-draining of condensation regardless of mounting position and topworks rotation.

Wiring Guides and Terminations provide ease of wire entry and support, plenty of space to work and store excess wire, and large, rugged, rugged screw terminals for easy wire termination.

PULP AND PAPER VERSIONS ALSO AVAILABLE

These transmitters are also available with integral process connections for use in pulp and paper installations. See PSS 2A-1C13 N.

OPTIONAL 15 Ra SEAL SURFACE FINISH

The standard seal surface finish provided is 32 Ra. An optional 15 Ra finish is offered with Transmitter Structure Codes TA, TB, T2 to T5, M1, M6, and M9. The 15 Ra finish is required by such industries as Biopharm and Pharmaceutical. Select Model Code Option -F1 for the seal surface to be polished to a 15 micro-inch finish.

OPTIONAL LCD DIGITAL INDICATOR

A two-line indicator with on-board pushbuttons is available to display the measurement with a choice of pressure units (Table 2), or percent. The pushbuttons allow zero and span adjustments as well as local configuration without the need for a HART Communicator or a PC-based configurator.

NOTE

When an LCD indicator is used, ensure that the largest value in the selected pressure units does not exceed the character capacity on the top line of the display; i.e., five numeric characters.

FUNCTIONAL SPECIFICATIONS

Span Limits

Span Limit Code	Span Limits		
	MPa	psi	bar
D	0.0035 and 1.4	0.5 and 200	0.035 and 14
E (a)	0.035 and 4.2	5 and 600	0.35 and 42

- a. Span Limit Code E only available with Structure Codes TA, TB, and T2 to T5 (Tri-Clamp structures).

Range Limits

Span Limit Code	Range Limits		
	MPa	psi	bar
D	0 and 1.4	0 and 200	0 and 14
E (a)	0.035 and 4.2	5 and 600	0 and 42

- a. Span Limit Code E only available with Structure Codes TA, TB, and T2 to T5 (Tri-Clamp structures).

Maximum Overrange Pressure Rating

Span Limit Code	Maximum Overrange Pressure Rating (a)		
	MPa	psi	bar
D	2.1	300	21
E (b)	6.2	900	62

- a. Overrange pressure is maximum pressure that may be applied without causing damage to transmitter.
 b. Maximum working pressure of transmitter with Tri-Clamp type connections is 4.2 MPa (600 psi), or the pressure rating of the Tri-Clamp type connection, whichever is less. See "ACCESSORIES" on page 19 for Tri-Clamp type connection ratings.

Output Signal (as specified)

- ▶ **Version -F Electronics**
Digital FOUNDATION fieldbus
- ▶ **Version -T Electronics**
Digital HART and 4 to 20 mA dc

Field Wiring Reversal

No transmitter damage.

Suppressed Zero

Suppressed zero ranges are acceptable as long as the Span and Range Limits are not exceeded.

Zero and Span Adjustments

Zero and span adjustments can be initiated from any of the following: I/A Series Workstation (with applicable FBMs), the HART Communicator, the PC-based configurator, or the LCD indicator with on-board pushbuttons.

Zeroing for Nonzero-Based Ranges

Dual Function Zeroing from the LCD pushbuttons allows zeroing with transmitter open to atmosphere, even when there is a nonzero-based range. This greatly simplifies position effect zeroing on many pressure and level applications. It also applies to the Optional External Zero Adjustment (further in document).

Adjustable Damping

Transmitter response time is normally 0.75 s, and electronically adjustable to 0.00 (none), 0.25, 0.50, 1, 2, 4, 8, 16, or 32 seconds, whichever is greater, for a 90% recovery from an 80% input step as defined in ANSI/ISA S51.1 (for a 63.2% recovery, 0.5 s). Damping can be set in both the transducer and AI blocks with the -F version.

Electronics and Sensor Temperatures

Readable from I/A Series system, a HART Communicator, or a PC-based configurator only. Measurement is transmitter temperature, not necessarily process temperature.

Supply Voltage

▶ **Digital Output**

– **Version -T Electronics (HART)**

Bidirectional digital signal superimposed on the 4 to 20 mA signal. See 4 to 20 mA output below.

– **Version -F Electronics (FOUNDATION Fieldbus)**

Power from a specific Fieldbus power supply.

▶ **4 to 20 mA Output (HART)**

Nominal minimum voltage (Figure 1) is 11.5 V dc. This value can be reduced to 11 V dc by using a plug-in jumper across test receptacles in the field wiring compartment terminal block (Figure 7).

Figure 1. 4 to 20 mA Output, Supply Voltage vs. Output Load

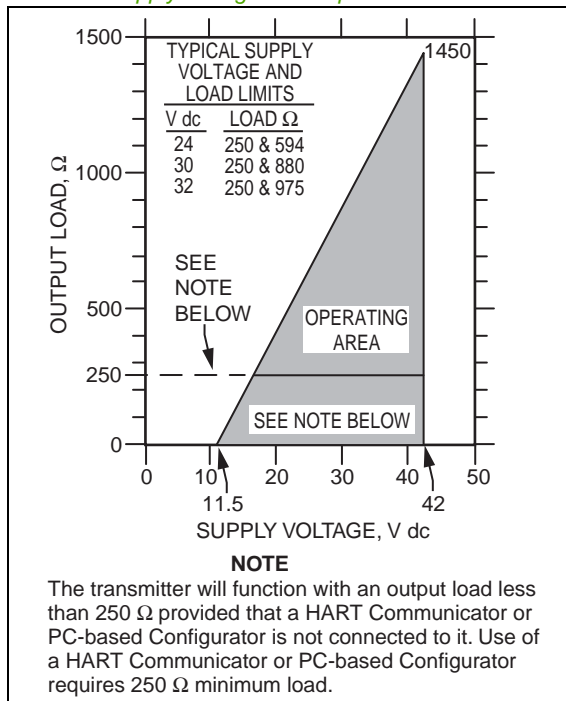

Current Outputs for Overrange, Fail, and Offline Conditions - HART Only

Parameter	HART
OFFLINE	User configurable between 4 and 20 mA
SENSOR FAILURE	User configurable to Fail LO or Fail HI
FAIL LO	3.60 mA
UNDERRANGE	3.80 mA
OVERRANGE	20.50 mA
FAIL HI	21.00 mA

Write Protect Jumper

Can be positioned to lock out all configurators from making transmitter database changes. This makes transmitter suitable for Safety Shutdown System Applications that require this feature.

HART (Version -T) Communications

▶ **4 to 20 mA Analog Mode**

Analog output signal is updated 30 times per second. A minimum loop load of 250 ohms is required. See Table 1 for communication parameters and Figure 3 for 4 to 20 mA output block diagram.

▶ **Multidrop Mode (Fixed Current)**

This Mode supports communications with up to 15 transmitters on a single pair of signal/power wires. The output signal is updated 4 times/second. A minimum loop load of 250 ohms is required. See Table 1 for communication parameters and Figure 6 for a typical multidrop block diagram.

FOUNDATION Fieldbus (Version -F) Communications

This version is a serial, two-way communication system that runs at 31.25 kbits/s. The digital output signal is superimposed on the dc power signal on the bus, and controlled by a strict cycle schedule and protocol.

Supply voltage, 9 to 32 V dc, is by a specific Fieldbus power source. Current consumption is 19.5 mA. The maximum number of devices on a non-intrinsically safe bus is 32. For intrinsically safe bus systems, the maximum number is 5. See Table 1 for communication parameters and Figures 4 and 6 for typical installation topologies.

Table 1. Communication Parameters - HART and FOUNDATION Fieldbus

Parameter	HART		Fieldbus
	Analog Mode	Multidrop Mode	Digital
Remote Configurator	HART Communicator or PC-based Configurator		I/A Series System, PC or Fieldbus Host
Communication Rate	1200 baud	1200 baud	31.25 kbits/s
Communication Distance	3050 m (10 000 ft)	1525 m (5000 ft)	1900 m (6235 ft) (a)

a. The total bus length including all spurs. Maximum spur length is 120 m (395 ft). For hybrid installations, the maximum IS spur length is dependent on the field barrier used. For intrinsically safe installations, maximum spur length is 30 m (98 ft).

Configuration Capability

Numerous parameters can be configured and/or displayed such as electronic damping, failsafe direction, transmitter location, calibration, tag data, etc. See applicable configuration instructions for details.

- ▶ Calibrated Range
 - Input range within Span and Range Limits.
 - Pressure EGU (see Table 2).
- ▶ Output Measurement #1 — Digital Primary Variable and 4 to 20 mA (HART Only)
 - Mode: Linear
 - Units: Same as calibrated range
- ▶ Output Measurement #2 — Digital Secondary Variable
 - Mode: Linear
 - Units: A common pressure EGU
- ▶ Measurements #1 and #2 may be swapped.

Table 2.

Allowable Pressure Units for Calibrated Range

inH ₂ O	inHg	Pa	mbar	psi
ftH ₂ O	mmHg	kPa	bar	atm
mmH ₂ O	kg/cm ²	MPa	g/cm ²	torr

Configuration and Calibration Data, and Electronics Upgradeability

All factory characterization data, and user configuration and calibration data are stored in the sensor. This means that the electronics module can be replaced or changed from one type to another.

A module may be replaced without the need for reconfiguration or recalibration. Although module replacement can affect accuracy up to 0.20% of span, this error can be removed by an mA trim without application of pressure (not with Fieldbus).

Changing module types may require reconfiguration and recalibration, as well as a different terminal block, if applicable, but all factory characterization data is retained.

Optional LCD Digital Indicator with On-Board Pushbuttons (Figure 2)

Indicator provides:

- ▶ Two Lines; five numeric characters on top line (four when a minus sign is needed) and seven alphanumeric characters on bottom line.
- ▶ Measurement Readout; value on top line and units label on bottom line.
- ▶ Configuration and Calibration Prompts.

Two pushbuttons provide for:

- ▶ Configuration Functions
- ▶ Calibration Functions

Figure 2. LCD Indicator with Pushbuttons

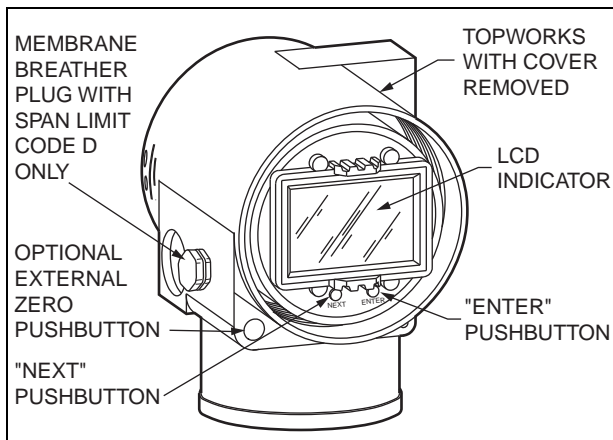

Optional External Zero Adjustment

An external pushbutton mechanism (Figure 2) is isolated from the electronics compartment and magnetically activates an internal reed switch through the housing. This eliminates a potential leak path for moisture or contaminants to get into the electronics compartment. This zero adjustment can be disabled by a configuration selection.

Optional Custom Configuration (Option -C2)

For the transmitter to be custom configured by the factory, the user must fill out a data form. If this option is not selected, a standard default configuration will be provided; for example:

Parameter	Standard (Default) Configuration	Example of Custom Configuration Option -C2
Measurement 1	Linear	Linear
Device Name	DevNam	FT103A
External Zero	Enabled	Disabled
EGU	%	inH ₂ O
Damping	None	0.5 s

Functional Block Diagrams

Refer to Figures 3 through 5 for typical HART and FOUNDATION Fieldbus installation topologies.

Figure 3. HART 4 to 20 mA Topology

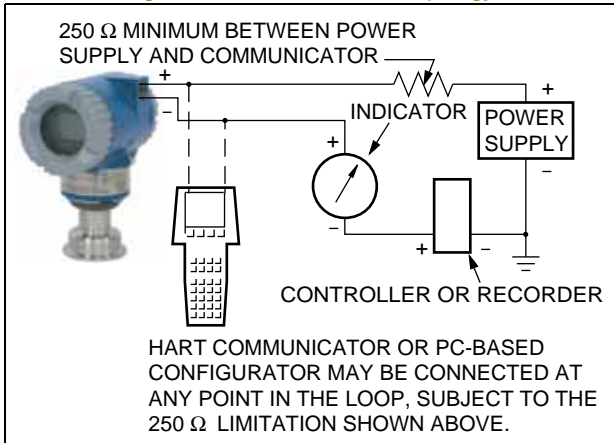

Figure 5. HART Multidrop Topology

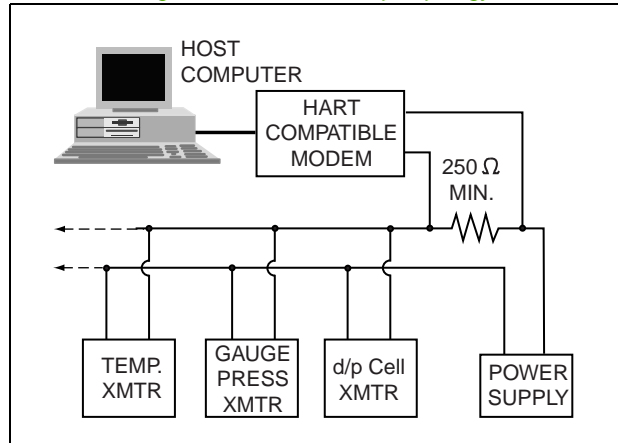

Figure 4. Fieldbus Miscellaneous Topologies

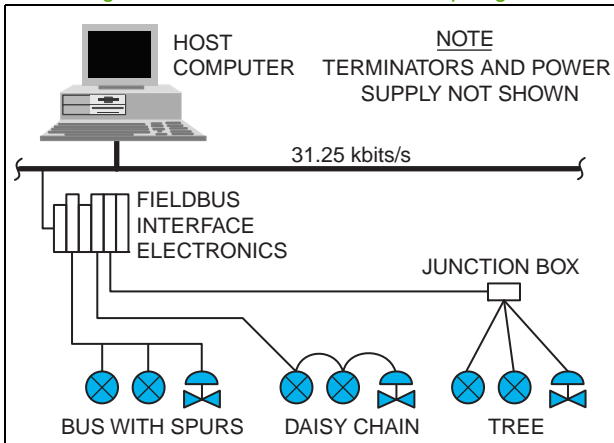
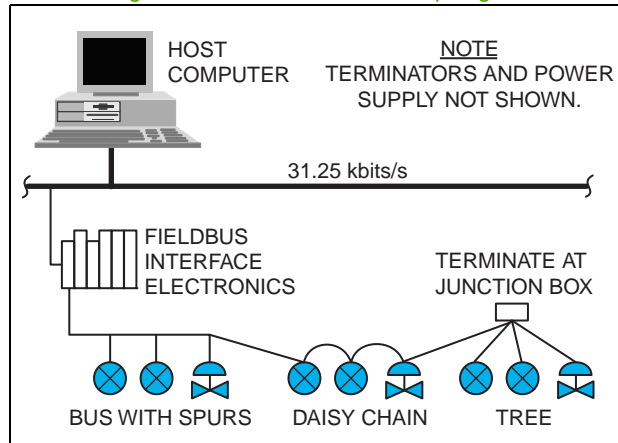

Figure 6. Fieldbus with Mixed Topologies



OPERATING, STORAGE, AND TRANSPORTATION CONDITION

Influence	Reference Operating Conditions	Normal Operating Conditions (a)	Operative Limits (a)	Transportation/Storage Limits
Process Connection Temp. ▶ w/Silicone Fill Fluid	24 ± 2°C (75 ± 3°F)	-29 to +82°C (-20 to +180°F)	-46 and +121°C (-50 and +250°F)	Not Applicable
▶ w/Fluorinert Fill Fluid	24 ± 2°C (75 ± 3°F)	-29 to +82°C (-20 to +180°F)	-29 and +121°C (-20 and +250°F)	Not Applicable
Electronics Temperature	24 ± 2°C (75 ± 3°F)	-29 to +82°C (c) (-20 to +180°F) (c)	-40 and +85°C (c) (-40 and +185°F) (c)	-54 and +85°C (-65 and +185°F)
▶ with LCD Indicator (b)	24 ± 2°C (75 ± 3°F)	-20 to +82°C (c) (-4 to +180°F) (c)	-29 and +85°C (c) (-20 and +185°F) (c)	-54 and +85°C (-65 and +185°F)
Relative Humidity (d)	50 ±10%	0 to 100%	0 and 100%	0 and 100% (d) Noncondensing
Supply Voltage – mA Output HART	30 ±0.5 V dc	11.5 to 42 V dc (e)	11.5 and 42 V dc (e)	Not Applicable
Output Load – mA Output HART	650 Ω (see Figure 3)	0 to 1450 Ω (f)	0 and 1450 Ω (f)	Not Applicable
Supply Voltage FOUNDATION Fieldbus	30 ±0.5 V dc	9 to 32 V dc (g)	9 and 32 V dc (g)	Not Applicable
Vibration	1 m/s ² (0.1 “g”)	6.3 mm (0.25 in) Double Amplitude: from 5 to 15 Hz with Aluminum Housing from 5 to 9 Hz with 316 ss Housing 0 to 30 m/s ² (0 to 3 “g”) from 15 to 500 Hz with Aluminum Housing; 0 to 10 m/s ² (0 to 1 “g”) from 9 to 500 Hz with 316 ss Housing		11 m/s ² (1.1 “g”) from 2.5 to 5 Hz (in Shipping Package)
Mounting Position	Upright	Upright	No Limit	Not Applicable

- a. Normal Operating Conditions and Operative Limits are defined per ANSI/ISA 51.1-1979 (R1993).
- b. The optional LCD will not be damaged at any temperature within the Transportation/Storage Limits; however, updates will be slowed and readability decreased at temperatures outside the Normal Operating Conditions.
- c. Refer to the “ELECTRICAL SAFETY SPECIFICATIONS” on page 13 for a restriction in ambient temperature with certain electrical certifications.
- d. With topworks cover on and conduit entrances sealed. Also noncondensing during transportation and storage.
- e. 11.5 V dc can be reduced to 11 V dc by using a Foxboro plug-in shorting bar. See “PHYSICAL SPECIFICATIONS” on page 11.
- f. With HART, 250 Ω minimum load required for proper communication.
- g. Power supplied by a specific Fieldbus power supply.

PERFORMANCE SPECIFICATIONS

*Zero-Based Calibrations; Under Reference Operating Conditions Unless Otherwise Specified;
URL = Upper Range Limit; Span = Calibrated Span*

Accuracy (Includes Linearity, Hysteresis, and Repeatability)

±0.10% of Span

Small Span Accuracy - Spans Less than 0.83% of URL (Turndown Greater than 120:1)

±(0.000833)(URL/Span)% of Span

Stability

Long term drift is ±0.15% of URL for 10 years (reference conditions).

Calibration Frequency

The calibration frequency is five years. The five years is derived using the values of allowable error (% span), TPE (% span), performance margin (% span), and stability (% span/month); where:

$$\text{Calibration Frequency} = \frac{\text{Performance Margin}}{\text{Stability}} = \text{Months}$$

Power-Up Time

Less than 5 seconds for output to reach first valid measurement.

Vibration Effect

Total effect is ±0.2% of URL per “g” for vibrations in the frequency range of 5 to 500 Hz; with double amplitudes of 6.3 mm (0.25 in) in the range of 5 to 15 Hz, or accelerations of 3 “g” in the range of 15 to 500 Hz, whichever is smaller, for aluminum housings; and with double amplitudes of 6.3 mm (0.25 in) in the range of 5 to 9 Hz, or accelerations of 1 “g” in the range of 9 to 500 Hz, whichever is smaller, for 316 ss housings.

Supply Voltage Effect

The output changes less than 0.005% of span for each 1 V change within the specified supply voltage requirements.

Ambient Temperature Effect

Total effect for a 28°C (50°F) change within Normal Operating Condition limits is:

$$\pm(0.06\% \text{ URL} + 0.12\% \text{ Span})$$

RFI Effect

The output error is less than 0.1% of span for radio frequencies in the range of 27 to 1000 MHz and field intensity of 30 V/m when the transmitter is properly installed with shielded conduit and grounding, and housing covers are in place. (Per IEC Std. 61000-4-3.)

Position Effect

Any zero effect caused by the mounting position can be eliminated by rezeroing. There is no span effect.

Switching and Indirect Lightning Transients

The transmitter can withstand a transient surge up to 2000 V common mode or 1000 V normal mode without permanent damage. The output shift is less than 1.0%. (Per ANSI/IEEE C62.41-1980 and IEC Std. 61000-4-5.)

PHYSICAL SPECIFICATIONS

Environmental Protection

The enclosure has the dusttight and weatherproof rating of IP66 as defined by IEC 60529, and provides the environmental and corrosion resistant protection rating of NEMA 4X.

Electronics Housing and Housing Covers

Housing has two compartments to separate the electronics from the field connections. The housing and covers are made from low copper (0.6% maximum) die-cast aluminum alloy with an epoxy finish, or from 316 ss. Buna-N O-ring seals are used to seal the threaded housing covers, housing neck, and terminal block.

Process Connectors

Selection of Tri-clamp type or mini-tank spud type process connection. Refer to "MODEL CODE" on page 16.

Process Wetted Parts

- ▶ 316L ss
- ▶ Nickel alloy⁽³⁾ diaphragm material also available - see "MODEL CODE" on page 16.

Process O-Rings (Mini Tank Spud Versions)

EPDM

Sensor Fill Fluid

Neobee M-20

Mounting Position

The transmitter should be mounted in such a way that nonprocess wetted surfaces are self draining. It should be installed horizontal to vertical, so that the crevice at the feature where the housing is attached to the sensor (neck) is self draining. Process wetted surface (diaphragm convolutions) should be installed so that process does not pool between convolutions when the vessel is empty.

Electronics Module

Printed wiring assemblies are conformally coated for moisture and dust protection.

Electrical Connections

Field wires enter through 1/2 NPT, PG 13.5, or M20 threaded entrances on either side of the electronics housing. Wires terminate under screw terminals and washers on terminal block in the field terminal compartment (Figure). Unused entrance is plugged to insure moisture and RFI/EMI protection.

Approximate Mass

- ▶ 1.5 to 3 kg (3.3 to 6.7 lb), depending on process connector type and size selected, when aluminum housing is used.
- ▶ Add 1.1 kg (2.4 lb) if 316 ss housing is used
- ▶ Add 0.2 kg (0.4 lb) if LCD indicator is used

3. Equivalent to Hastelloy® C-276.

Figure 7. Field Terminals Compartment for the Electronic Versions Offered

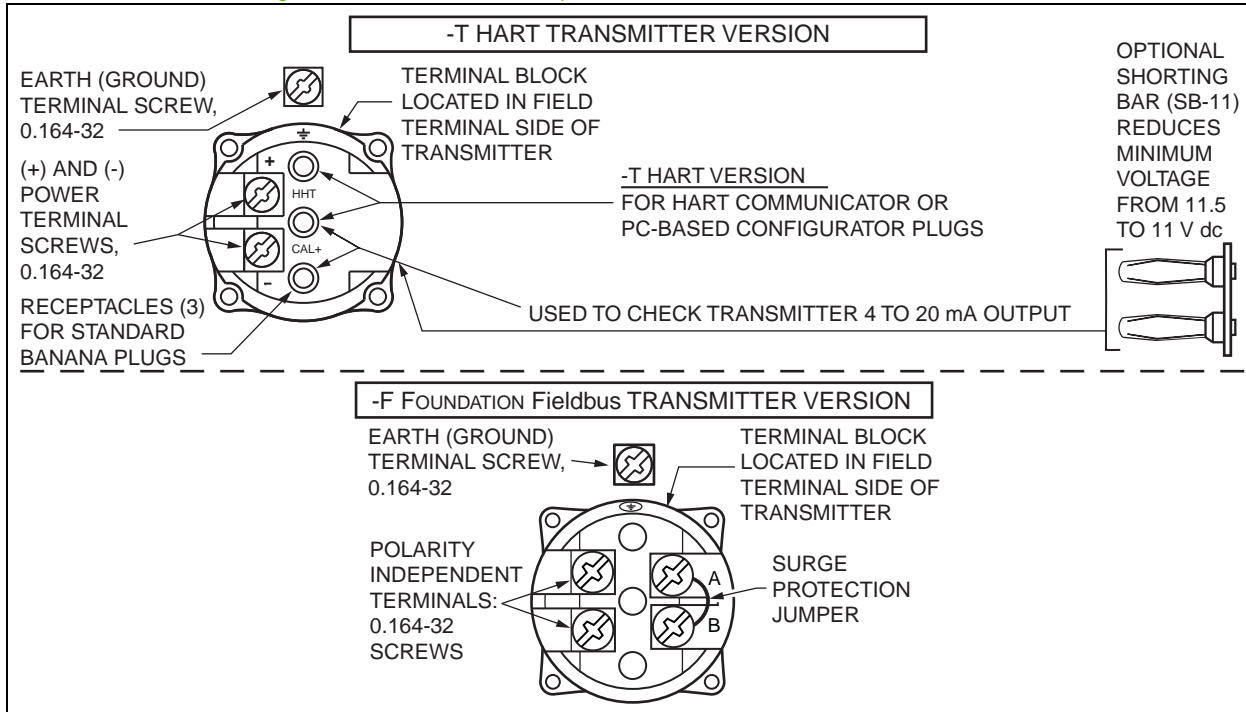

ELECTRICAL SAFETY SPECIFICATIONS

Transmitter has been designed to meet the Electrical Safety Specifications listed in the tables that follow. Contact Global Customer Support for information or status of testing laboratory approvals or certifications.

Refer to applicable instruction manual for application conditions and connectivity requirements.

Electronic Version -T (HART)

Testing Laboratory, Types of Protection, and Area Classification	Application Conditions	Elec. Safety Design Code
ATEX intrinsically safe; II 1 GD, EEx ia IIC, Zone 0, or II 1/2 GD EEx ib IIC, Zone 0/Zone 1.	Temperature Class T4; Ta = -40 to +80°C Temperature Class T5; Ta = -40 to +40°C Temperature Class T6; Ta = -40 to +40°C	E
ATEX protection n; II 3 GD, EEx nL IIC, Zone 2.	Temperature Class T4; Ta = -40 to +80°C Temperature Class T5; Ta = -40 to +70°C Temperature Class T6; Ta = -40 to +40°C	N
ATEX multiple certifications, ia & ib, and n. Refer to Codes E and N for details.	Applies to Codes E and N, but not to Code D.	M (a)
CSA intrinsically safe for Class I, Division 1, Groups A, B, C, and D, Class II, Division 1, Groups E, F, and G, and Class III, Division 1.	Temperature Class T4A at 40°C, and T3C at 85°C maximum ambient.	L
CSA zone certified intrinsically safe Ex ia IIC, and energy limited Ex nA II.	Temperature Class T4 at 40°C, and T3 at 85°C maximum ambient.	L
CSA for Class I, Division 2, Groups A, B, C, and D; Class II, Division 2, Groups F and G; Class III, Division 2.	Temperature Class T4A at 40°C and T3C at 85°C maximum ambient.	L
FM intrinsically safe for Class I, Division 1, Groups A, B, C, and D; Class II, Division 1, Groups E, F, and G; and Class III, Division 1.	Temperature Class T4A at 40°C and T4 at 85°C maximum ambient.	R
FM zone certified intrinsically safe AEx ia IIC.	Temperature Class T4 at 85°C maximum ambient.	R
FM nonincendive Class I, Division 2, Groups A, B, C, and D; Class II, Division 2, Groups F and G; and Class III, Division 2.	Temperature Class T4A at 40°C and T4 at 85°C maximum ambient.	R
SAA intrinsically safe, Ex ia IIC, Gas Group IIC, Zone 0.	Temperature Class T4 at 85°C maximum ambient.	H
SAA nonincendive, Ex n IIC, Gas Group IIC, Zone 2.	Temperature Class T6.	K
IECEx field device intrinsically safe; Ex ia IIC, Zone 0.	Temperature Class T4; Ta = -40 to +80°C.	T

Electronic Version -T (HART) (Continued)

Testing Laboratory, Types of Protection, and Area Classification	Application Conditions	Elec. Safety Design Code
IECEx field device protection n; Ex nL IIC, Zone 2.	Temperature Class T4; Ta = -40 to +80°C.	U
Multi-marked as follows: <ul style="list-style-type: none"> ▶ CSA intrinsically safe, Cl. I, Div. 1, Groups A, B, C, D; Class II, Div. 1, Groups E, F, G; Class III, Div. 1; also CSA zone certified intrinsically safe Ex ia IIC. ▶ FM intrinsically safe, Cl. I, Div. 1, Groups A, B, C, D; Class II, Div. 1, Groups E, F, G; Class III, Div. 1. Also FM zone certified intrinsically safe AEx ia IIC. ▶ ATEX intrinsically safe, II 1 GD, EEx ia IIC, Zone 0. 	<ul style="list-style-type: none"> ▶ See application conditions for Code C intrinsically safe applications. ▶ See application conditions for Code F intrinsically safe applications. ▶ See application conditions for Code E intrinsically safe applications. 	W (b)

- a. With Electrical Safety Design Code M, the user must permanently mark (check off on rectangular box on data plate) one type of protection only (ia and ib, or n). Do not change this mark once it has been applied.
- b. When selecting Safety Design Code W (for HART only), the user must permanently mark (check off in rectangular block on data plate) intrinsically safe certifications for ATEX, CSA, or FM, as applicable. Do not change this mark once it has been applied.

Electronic Version -F (FOUNDATION Fieldbus)

Testing Laboratory, Types of Protection, and Area Classification	Application Conditions	Elec. Safety Design Code
ATEX FISCO field device intrinsically safe; II 1 G, EEx ia IIC, Zone 0.	Temperature Class T4; Ta = -40 to +80°C.	E
ATEX FNICO field device protection n: II 3, G EEx nL IIC, Zone 2.	Temperature Class T4; Ta = -40 to +80°C.	N
CSA intrinsically safe for Class I, Division 1, Groups A, B, C, and D; Class II, Division 1, Groups E, F, and G; and Class III, Division 1.	Temperature Class T6 at 40°C, and T4A at 85°C maximum ambient.	L
CSA for Class I, Division 2, Groups A, B, C, and D; Class II, Division 2, Groups F, and G; and Class III, Division 2.	Temperature Class T6 at 40°C, and T4A at 85°C maximum ambient.	L
CSA FISCO field device intrinsically safe for Class I, Div. 1, Groups A, B, C, and D; Class II, Div. 1, Groups E, F, G; Class III Div. 1.	Temperature Class T6 at 40°C and T4A at 85°C maximum ambient.	L
CSA FNICO field device for Class I, Div. 2, Groups A, B, C, and D; Class II, Div. 2, Groups F and G; Class III Div. 2.	Temperature Class T6 at 40°C and T4A at 85°C maximum ambient.	L
FM intrinsically safe for Class I, Division 1, Groups A, B, C, and D; Class II, Division 1, Groups E, F, and G; and Class III, Division 1.	Temperature Class T4A at 40°C, and T4 at 85°C maximum ambient.	R
FM nonincendive for Class I, Division 2, Groups A, B, C, and D; Class II, Division 2, Groups F and G; and Class III, Division 2.	Temperature Class T4A at 40°C, and T4 at 85°C maximum ambient.	R
FM FISCO field device intrinsically safe for Class I, Div. 1, Groups A, B, C, and D; Class II, Div. 1, Groups E, F, G; Class III Div. 1.	Temperature Class T4A at 40°C and T4 at 85°C maximum ambient.	R
FM FNICO field device nonincendive for Class I, Div 2, Groups A, B, C, and D; Class II, Div. 2, Groups F and G; Class III, Div. 2.	Temperature Class T4A at 40°C and T4 at 85°C maximum ambient.	R
IECEX FISCO field device intrinsically safe; Ex ia IIC, Zone 0.	Temperature Class T4; Ta = -40 to +80°C.	T
IECEX FNICO field device protection n; Ex nL IIC, Zone 2.	Temperature Class T4; Ta = -40 to +80°C.	U

MODEL CODE

<u>Description</u>				<u>Model</u>
IGP25 Multirange, Gauge Pressure Transmitter with Sanitary Process Connections				IGP25
Electronics Versions and Output Signal				
Intelligent; Digital HART and 4 to 20 mA (Version -T)				-T
Intelligent; Digital FOUNDATION fieldbus (Version -F)				-F
Structure Code – Materials, Fill Fluid, and Process Connector Type (a)				
Connection Material	Diaphragm Material	Fill Fluid	Process Connector	
316L ss	316L ss	NEOBEE M-20	1.5-in Tri-Clamp Type, Sanitary (b) (c)	TA
316L ss	316L ss	NEOBEE M-20	2.0-in Tri-Clamp Type, Sanitary (b) (c)	T2
316L ss	316L ss	NEOBEE M-20	3.0-in Tri-Clamp Type, Sanitary (b) (c)	T3
316L ss	Nickel alloy (d)	NEOBEE M-20	1.5-in Tri-Clamp Type, Sanitary (b) (c)	TB
316L ss	Nickel alloy (d)	NEOBEE M-20	2.0-in Tri-Clamp Type, Sanitary (b) (c)	T4
316L ss	Nickel alloy (d)	NEOBEE M-20	3.0-in Tri-Clamp Type, Sanitary (b) (c)	T5
316L ss	316L ss	NEOBEE M-20	Mini Tank Spud Seal, 1 1/2-in extension (b) (e)	M1
316L ss	316L ss	NEOBEE M-20	Mini Tank Spud Seal, 6-in extension (b) (e)	M6
316L ss	316L ss	NEOBEE M-20	Mini Tank Spud Seal, 9-in extension (b) (e)	M9
Span Limits				
MPa	psi	bar		
0.0035 and 1.4	0.5 and 200	0.035 and 14		D
0.035 and 4.2	5 and 600	0.35 and 42		E (f)
Conduit Connection and Housing Material				
1/2 NPT Conduit Connection (both sides), Aluminum Housing				1
PG 13.5 Conduit Connection (both sides), Aluminum Housing (with Elect. Safety Codes E, N, and M only)				2
1/2 NPT Conduit Connection (both sides), 316 ss Housing				3
PG 13.5 Conduit Connection (both sides), 316 ss Housing (with Elect. Safety Codes E, N, and M only)				4
M20 Conduit Connection (both sides), Aluminum Housing (with Elect. Safety Codes E, N, and M only)				5
M20 Conduit Connection (both sides), 316 ss Housing (with Elect. Safety Codes E, N, and M only)				6

MODEL CODE

MODEL CODE (CONTINUED)

Description	Model
Electrical Safety (See "ELECTRICAL SAFETY SPECIFICATIONS" on page 13 for Description)	
ATEX II 1 GD, EEx ia IIC, Zone 0; or II 1/2 GD, EEx ib IIC, Zone 0/Zone 1 (with Electronics Version -T only)	E
ATEX FISCO II 1 G, EEx ia IIC, Zone 0 (with Electronics Version -F only)	E
ATEX Protection n, II 3 GD, EEx nL IIC, Zone 2 (with Electronics Version -T only)	N
ATEX FNICO field device Protection n; II 3 G, EEx nL IIC, Zone 2 (with Electronics Version -F only)	N
ATEX Multiple Certifications (includes ATEX Codes E and N) (with Electronics Version -T only) (See "ELECTRICAL SAFETY SPECIFICATIONS" on page 13 for user marking.)	M
CSA Certifications:	
Intrinsically safe, Division 1, Classes I, II, and III; and Suitable for Division 2, Classes I, II, and III	L
Zone certified Ex ia IIC and Ex nA II (Electronics Version -T only)	
FISCO intrinsically safe, Division 1, Classes I, II, and III (Electronics Version -F only)	
FNICO Division 2, Classes I, II, and III (Electronics Version -F only)	
FM Approvals:	
Intrinsically safe, Division 1, Classes I, II, and III; and Nonincendive, Division 2, Classes I, II, and III	R
Zone approved AEx ia IIC and AEx nA II (Electronics Version -T only)	
FISCO intrinsically safe, Division 1, Classes I, II, and III (Electronics Version -F only)	
FNICO nonincendive Division 2, Classes I, II, and III (Electronics Version -F only)	
SAA intrinsically safe, Ex ia IIC, Zone 0 (with Electronics Version -T only)	H
SAA nonincendive, Ex n IIC, Zone 2 (with Electronic Version -T only)	K
IECEx FISCO, Ex ia IIC, Zone 0 (Versions -T and -F only)	T
IECEx FNICO, Ex nL IIC, Zone 2 (Versions -T and -F only)	U
Multi-marked for ATEX, CSA, and FM Intrinsically Safe Applications (Version -T only) (g)	W
Optional Selections	
Digital Indicator with Pushbuttons	
Digital Indicator, Pushbuttons, and Window Cover	-L1
Conduit Thread Adapters	
Hawke-Type 1/2 NPT Cable Gland for use with Conduit Connection Codes 1 and 3 (h)	-A1
Plastic PG 13.5 Cable Gland for use with Conduit Connection Codes 2 and 4 (i)	-A2
M20 Connector for use with Conduit Connection Codes 1 and 3 (h)	-A3
Brass PG 13.5 Cable Gland (Trumpet-Shaped) for use with Conduit Codes 2 and 4 (i)	-A4
Electronics Housing Features	
External Zero Adjustment	-Z1
Custody Transfer Lock and Seal	-Z2
External Zero Adjustment and Custody Transfer Lock and Seal	-Z3
Custom Factory Configuration	
Full Factory Configuration (Requires Configuration Form to be filled out)	-C2
Cleaning and Preparation	
Unit Degreased - for Silicone Filled Sensors Only (Not for Oxygen/Chlorine Service)	-X1
Cleaned and Prepared for Oxygen Service - for Fluorinert Filled Sensors Only	-X2
Seal Surface Finish	
15 Ra Seal Surface Finish (b)	-F1

MODEL CODE (CONTINUED)

Description	Model
Instruction Books (Common MI, Brochure, and Full Documentation Set on DVD is Standard) Without Instruction Book and DVD - Only "Getting Started" Brochure is supplied	-K1
Miscellaneous Optional Selections Supplemental Customer Tag (Stainless Steel Tag wired onto Transmitter) Seventeen Year Warranty	-T -W
EXAMPLE: IGP25-TT2D1N-C2L1W	

- a. The maximum working pressure for transmitters with Tri-Clamp type connections is 2100 kPa (300 psi). When using Tri-Clamp connections, the pressure rating is 2100 kPa (300 psi), or the pressure rating of the Tri-Clamp, whichever is less.
- b. Option -F1 (15 Ra finish) only with Structure Codes TA, TB, T2 to T5, M1, M6, M9. The standard seal surface finish is 32 Ra.
- c. Tri-Clamp type Transmitters (TA, T2, T3, TB, T4, T5) rely on user-supplied clamps and gaskets.
- d. Equivalent to Hastelloy® C-276.
- e. Mini Tank Spud Transmitters (M1, M6, M9) are supplied with clamps and gaskets. All spuds (accessories) are specified by part number.
- f. Span Limit Code E is only available with Structure Codes TA, TB, and T2 to T5 (Sanitary Tri-Clamp Structures). Normally Code E has a span limit of 14 MPa (2000 psi) which is the limit of the transmitter itself. However, with Tri-Clamps, the limit is derated to 4.2 MPa (600 psi), or the rating of the Tri-Clamp type connector, whichever is less.
- g. For multi-marking details, see **"ELECTRICAL SAFETY SPECIFICATIONS" on page 13.**
- h. Available with Electrical Safety Codes E, M, and N only.
- i. Available with Electrical Safety Code E only.

ACCESSORIES

Accessories are ordered and supplied separately.

Refer to "[DIMENSIONS - NOMINAL](#)" on [page 21](#) for configuration and dimensions of accessories listed.

Weld Spuds and O-Rings

Description	Used with Structure Code	Part Number
For use with Mini Tank Spud Connector		
Weld Spud, 1.5-inch Extension (a)	M1	N1212GG
Weld Spud, 6-inch Extension (a)	M6	N1214BP
Weld Spud, 9-inch Extension (a)	M9	N1214BQ
O-Rings (b)	M1, M6, M9	N1212LB

- Weld spuds are supplied by user.
- Part number is for a package of five O-rings. Each transmitter is shipped with its required O-rings. This package of O-rings is recommended extras or spares.

Tri-Clamp Type Connectors Supplied by User Unless Otherwise Noted (a)

Nominal Tube O.D.	MWP at 70°F	MWP at 250°F	Part Number
1.5 in Tube	500 psi	300 psi	N1212DA
2 in Tube	450 psi	300 psi	N1212DB
3 in Tube	350 psi	195 psi	N1212DC
1.5 in Tube	600 psi	300 psi	N1211PP
2 in Tube	550 psi	275 psi	N1211PQ
2.5 in Tube (b)	450 psi	225 psi	N1212HG
3 in Tube	350 psi	175 psi	N1211PR
1.5 in Tube	1500 psi	1200 psi	N1212FV
2 in Tube	1000 psi	800 psi	N1212FW

- The maximum working pressure (MWP) of the transmitter system is 2.1 MPa (300 psi), or the MWP of the Tri-Clamp type connectors, whichever is less.
- The Foxboro N1212HG Tri-Clamp type connector for a 2.5 in Tube is used with Mini Tank Spud connectors M1, M6, and M9.

SUGGESTED RFQ SPECIFICATIONS

The manufacturer shall provide direct connected, multirange pressure transmitters featuring HART or FOUNDATION Fieldbus Communication Protocol. They shall provide remote digital communications capability for measuring gauge pressure and transmit a digital or 4 to 20 mA (HART only) output signal for use in a standard two-wire dc supply voltage system. The transmitter shall have integral process connectors for use in sanitary processes. Specifications for these transmitters are as follows:

Communication Protocol:	HART digital signal superimposed on a 4 to 20 mA output signal; FOUNDATION fieldbus digital signal, 31.25 kbits/s
Remote Communications:	Must not interfere with the output signal.
Span Turndown Ratio:	400:1
Damping:	Suitable for a range of none to 32 seconds.
RFI Protection:	0.1% error between 27 and 1000 MHz at 30 V/m field intensity
Span Limits:	Code D Sensor; 0.5 and 200 psi (400-1 turndown - applicable to most sanitary process applications. Code E Sensor; 5 and 600 psi for certain higher pressure applications; transmitter can accommodate a 2000 psi limit, but reduced to be consistent with Tri-Clamp ratings.
Process Connectors:	Mount directly to process piping or tank spud: ▶ 1.5-, 2-, or 3-in Tri-Clamp Type ▶ 2.5-in Tri-Clamp Type for mini tank spud with 1 1/2-, 6-, or 9-in extension
Diaphragm Materials:	316L ss or nickel alloy (a) for Tri-Clamp connectors; 316L ss for spud-type connectors.
Electronics Housing:	316 ss, or Aluminum housing with Epoxy finish
Modular Electronics:	Enclosed in a housing with NEMA 4X and IP66 ratings and sealed with O-rings for double protection against moisture or other contaminants. Integral LCD Digital Indicator with on-board configuration pushbuttons is optional.
Electrical Classification:	Nonincendive for Class I and Class II, Division 2 locations; intrinsically safe or explosionproof for Class I and Class II, Division 1 locations. Comply with applicable European Union Directives. Versions available to meet agency zone requirements.
Approximate Mass:	With Aluminum Housing: 1.5 to 3 kg (3.3 to 6.7 lb), depending on process connector type and size With 316 ss Housing: Add 1.1 kg (2.4 lb) With LCD Indicator: Add 0.2 kg (0.4 lb)
Model Code:	I/A Series IGP25 Multirange, Gauge Pressure Transmitter having an integral Sanitary Process connector; with HART Communication Protocol, FOUNDATION Fieldbus Communication Protocol, or equivalent

a. Equivalent to Hastelloy® C-276.

DIMENSIONS - NOMINAL

$\frac{\text{mm}}{\text{in}}$

TRANSMITTERS WITH TRI-CLAMP PROCESS CONNECTORS

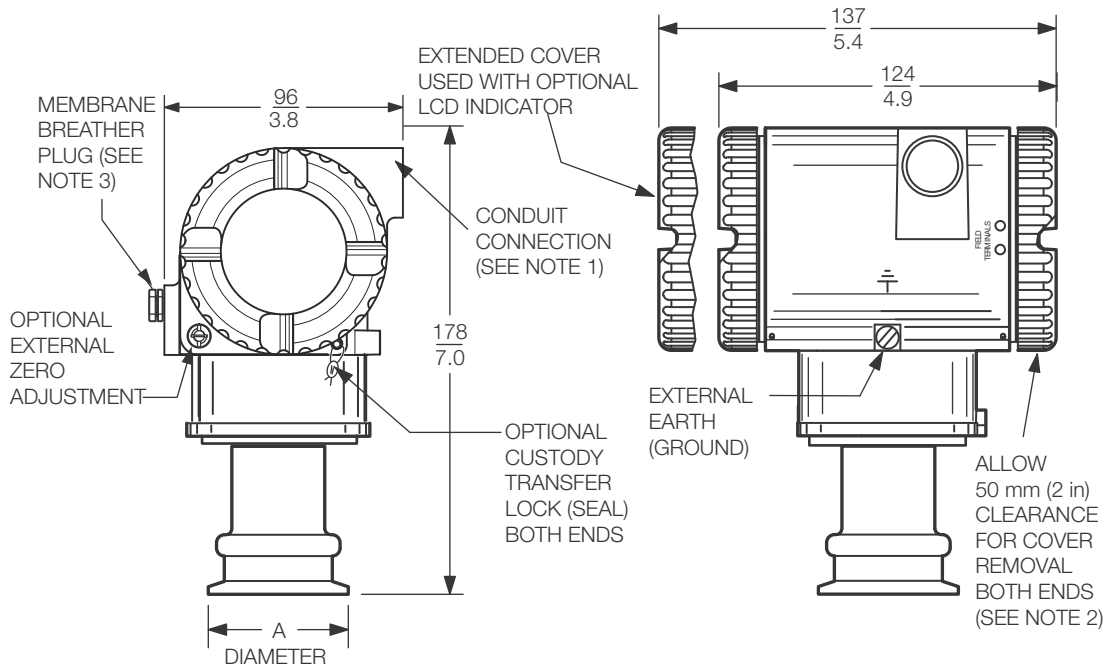

Structure Code	Diaphragm Material	Process Connector	Diameter "A"
TA	316L ss	1 1/2 in Tri-Clamp Type Connector	50.8 mm (2.00 in)
T2	316L ss	2 in Tri-Clamp Type Connector	63.5 mm (2.50 in)
T3	316L ss	3 in Tri-Clamp Type Connector	90.9 mm (3.58 in)
TB	Nickel alloy (a)	1 1/2 in Tri-Clamp Type Connector	50.8 mm (2.00 in)
T4	Nickel alloy (a)	2 in Tri-Clamp Type Connector	63.5 mm (2.50 in)
T5	Nickel alloy (a)	3 in Tri-Clamp Type Connector	90.9 mm (3.58 in)

a. Equivalent to Hastelloy® C-276.

NOTES

1. CONDUIT CONNECTION, 1/2 NPT, PG 13.5, OR M20, BOTH SIDES; PLUG UNUSED CONNECTION WITH METAL PLUG (SUPPLIED).
2. TOPWORKS ROTATABLE TO ANY POSITION WITHIN ONE TURN COUNTERCLOCKWISE OF FULLY TIGHTENED POSITION.
3. IGP25 TRANSMITTERS WITH SPAN LIMIT CODE E DO NOT REQUIRE A BREATHER PLUG.

**TRANSMITTERS WITH MINI TANK SPUD DIAPHRAGM SEALS
WITH A TRI-CLAMP PROCESS CONNECTOR**

**mm
in**

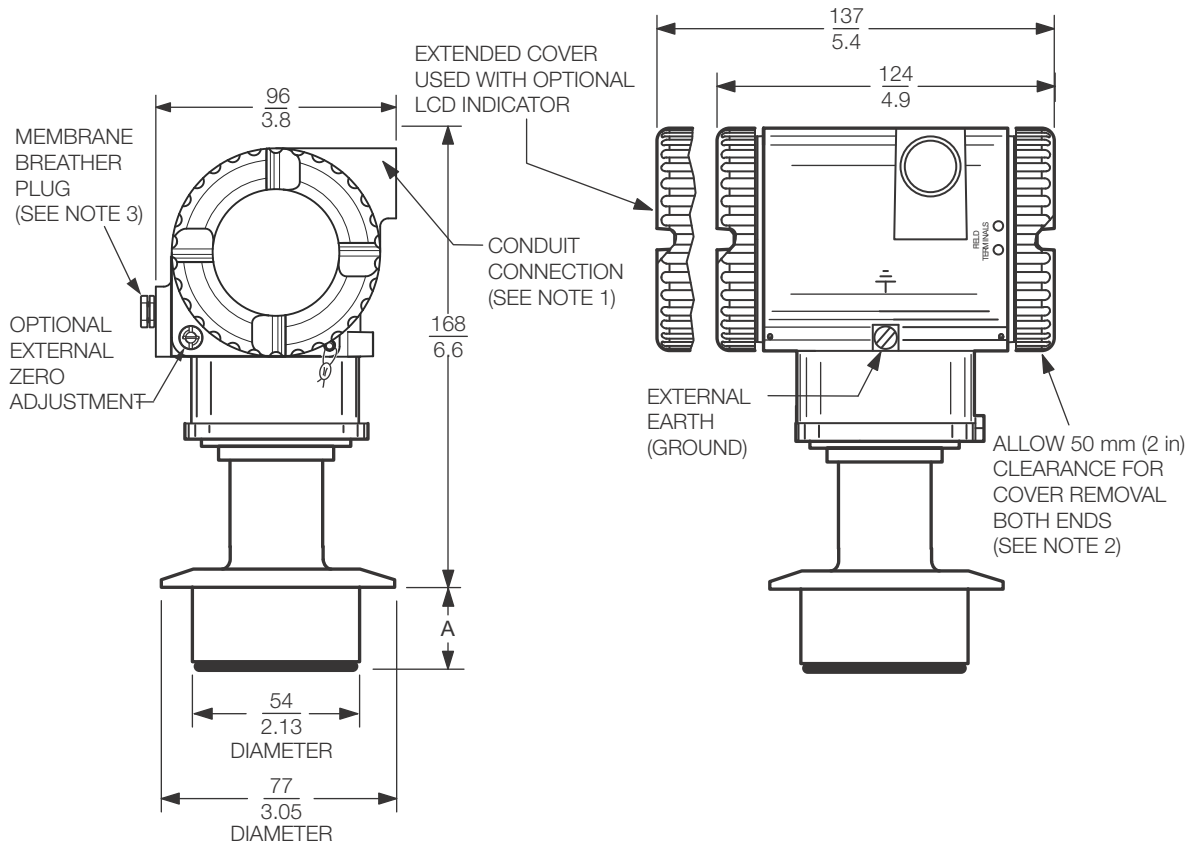

Structure Code	Diaphragm Material	Process Connector	Tank Spud Extension	Dimension "A"
M1	316L ss	2 1/2 in Tri-Clamp Type Connector	1 1/2 inch	38 mm (1.5 in)
M6	316L ss	2 1/2 in Tri-Clamp Type Connector	6 inch	152 mm (6.0 in)
M9	316L ss	2 1/2 in Tri-Clamp Type Connector	9 inch	229 mm (9.0 in)

NOTES

1. CONDUIT CONNECTION, 1/2 NPT, PG 13.5, OR M20, BOTH SIDES; PLUG UNUSED CONNECTION WITH METAL PLUG (SUPPLIED).
2. TOPWORKS ROTATABLE TO ANY POSITION WITHIN ONE TURN COUNTERCLOCKWISE OF FULLY TIGHTENED POSITION.
3. IGP25 TRANSMITTERS WITH SPAN LIMIT CODE E DO NOT REQUIRE A BREATHER PLUG.

ACCESSORIES

MINI TANK SPUDS

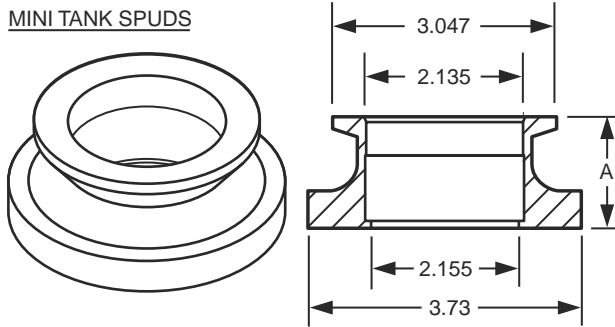

Part No.	A (Spud Extension)	Struct. Code
N1212GG	1.50	M1
N1214BP	6.00	M6
N1214BQ	9.00	M9

ORDERING INSTRUCTIONS

1. Model Number
2. Calibrated Pressure Range (use Allowable Pressure Units from table below)
3. Filled-out Configuration Form if Option -C2 is selected
4. Sanitary Process Accessories (see "ACCESSORIES" on page 19)
5. Transmitter Options and Accessories not in Model Code (see PSS 2A-1Z9 E)
6. User Tag Data - Data Plate; 32 characters maximum. For additional tag data, specify Optional Supplemental Tag -T.
7. User Tag Data - Software (Database):
 - ▶ HART, -T: 8 characters maximum
 - ▶ Fieldbus, -F: 32 characters maximum.

Allowable Pressure Units for Calibrated Range

inH ₂ O	inHg	Pa	mbar	g/cm ²	psia
ftH ₂ O	mmHg	kPa	bar	kg/cm ²	atm
mmH ₂ O		MPa	torr		

OTHER FOXBORO PRODUCTS

The Foxboro product lines offer a broad range of measurement and instrument products, including solutions for pressure, flow, analytical, temperature, positioning, controlling, and recording. For a list of these offerings, visit our web site at:

www.fielddevices.foxboro.com