

F153-A

PRESSURE INDICATOR WITH HIGH / LOW ALARMS

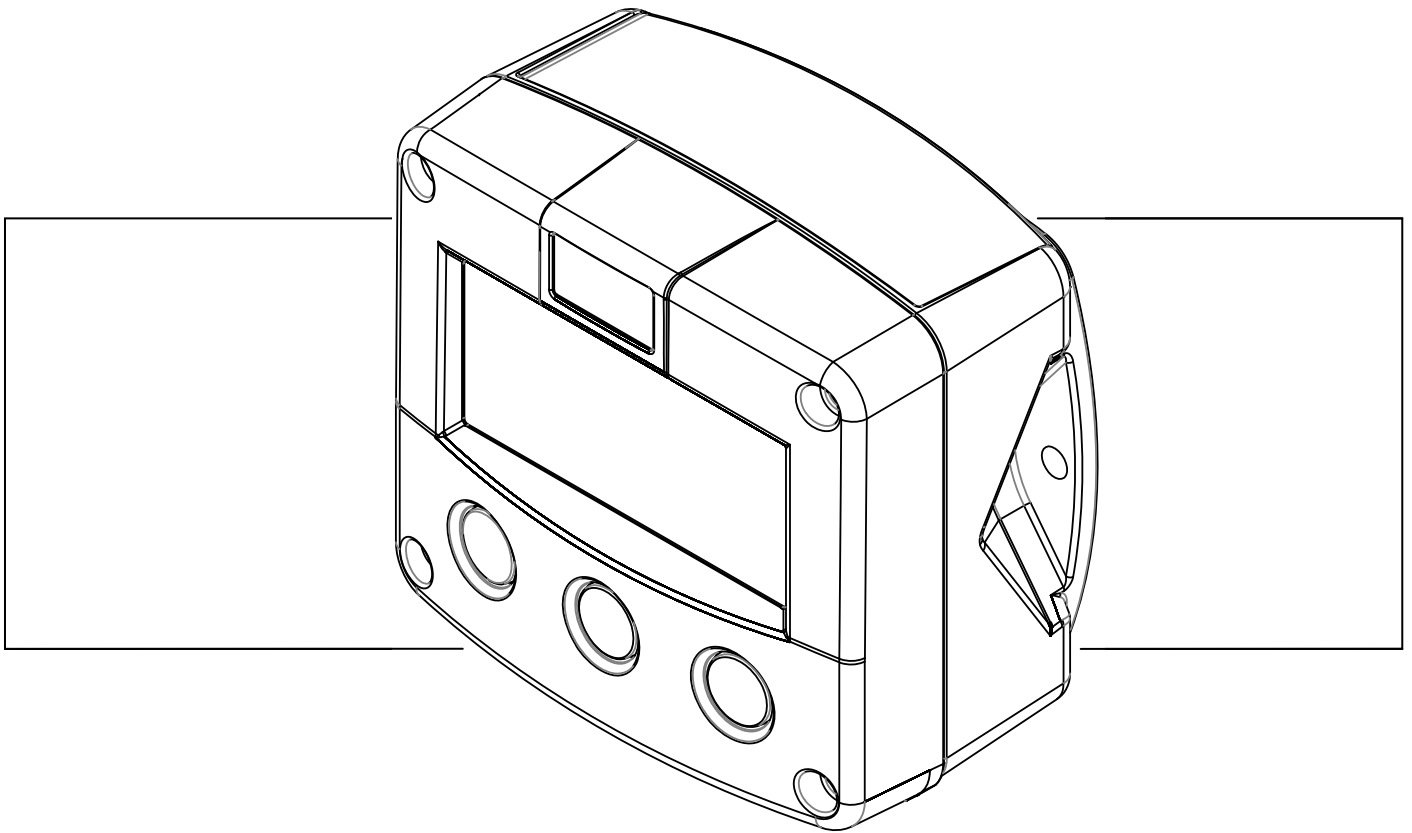

Signal input sensor: (0)4-20mA

Signal outputs: 4-20mA ref. pressure

Alarm outputs: maximum four pressure alarms

Options: Intrinsically Safe, Modbus communication



SAFETY INSTRUCTIONS



- Any responsibility is lapsed if the instructions and procedures as described in this manual are not followed.
- **LIFE SUPPORT APPLICATIONS:** The F153-A is not designed for use in life support appliances, devices, or systems where malfunction of the product can reasonably be expected to result in a personal injury. Customers using or selling these products for use in such applications do so at their own risk and agree to fully indemnify the manufacturer and supplier for any damages resulting from such improper use or sale.
- **Electro static discharge does inflict irreparable damage to electronics! Before installing or opening the unit, the installer has to discharge himself by touching a well-grounded object.**
- **This unit must be installed in accordance with the EMC guidelines (Electro Magnetic Compatibility).**
- **Do connect a proper grounding to the aluminum casing as indicated if the F153-A has been supplied with the 115-230V AC power-supply type PM. The green / yellow wire between the back-casing and removable terminal-block may never be removed.**
- **Intrinsically Safe applications: follow the instructions as mentioned in Chapter 5 and consult “Fluidwell F1...-XI - Documentation for Intrinsic Safety”.**

DISPOSAL



At the end of its life this product should be disposed of according to local regulations regarding waste electronic equipment. If a battery is present in this product it should be disposed of separately. The separate collection and recycling of your waste equipment will help to conserve natural resources and ensure that it is recycled in a manner that protects the environment.

SAFETY RULES AND PRECAUTIONARY MEASURES

- The manufacturer accepts no responsibility whatsoever if the following safety rules and precautions instructions and the procedures as described in this manual are not followed.
- Modifications of the F153-A implemented without preceding written consent from the manufacturer, will result in the immediate termination of product liability and warranty period.
- Installation, use, maintenance and servicing of this equipment must be carried out by authorized technicians.
- Check the mains voltage and information on the manufacturer's plate before installing the unit.
- Check all connections, settings and technical specifications of the various peripheral devices with the F153-A supplied.
- Open the casing only if all leads are free of potential.
- Never touch the electronic components (ESD sensitivity).
- Never expose the system to heavier conditions than allowed according to the casing classification (see manufacture's plate and chapter 4.2.).
- If the operator detects errors or dangers, or disagrees with the safety precautions taken, then inform the owner or principal responsible.
- The local labor and safety laws and regulations must be adhered to.

ABOUT THE OPERATION MANUAL

This operation manual is divided into two main sections:

- The daily use of the unit is described in chapter 2 "Operation". This instruction is meant for users.
- The following chapters and appendices are exclusively meant for electricians/technicians. These provide an extensive description of all software settings and installing the hardware.

This operation manual describes the standard unit as well as most of the Types available. For additional information, please contact your supplier.

A hazardous situation may occur if the F153-A is not used for the purpose it was designed for or is used incorrectly. Please carefully note the information in this operating manual indicated by the pictograms:



A "**warning**" indicates actions or procedures which, if not performed correctly, may lead to personal injury, a safety hazard or destruction of the F153-A or connected instruments.



Caution !

A "**caution**" indicates actions or procedures which, if not performed correctly, may lead to personal injury or incorrect function of the F153-A or connected instruments.



Note !

A "**note**" indicates actions or procedures which, if not performed correctly, may indirectly affect operation or may lead to an instrument response which is not planned.

Hardware Version	:	02.01.xx
Software Version	:	02.01.xx
Manual	:	HF153AEN_v0501_04
© Copyright 2011	:	Fluidwell bv - The Netherlands.

Information in this manual is subject to change without prior notice. The manufacturer is not responsible for mistakes in this material or for incidental damage caused as a direct or indirect result of the delivery, performance or use of this material.

© All rights reserved. No parts of this publication may be reproduced or used in any form or by any means without written permission of your supplier.

CONTENTS MANUAL

Safety instructions	2
Disposal	2
Safety rules and precautionary measures	2
About the operation manual	3
Contents manual.....	4
1. Introduction	5
1.1. System description of the F153-A.....	5
2. Operational.....	7
2.1. General	7
2.2. Control panel.....	7
2.3. Operator information and functions	8
3. Configuration	10
3.1. Introduction	10
3.2. Programming SETUP-level.....	10
3.2.1. General	10
3.2.2. Overview functions SETUP-level	13
3.2.3. Explanation SETUP-functions.....	14
1 - Pressure	14
2 - Alarm	15
3 - Display	15
4 - Power management	16
5 - Sensor	16
6 - Analog output.....	18
7 - Relay output.....	19
8 - Communication (Typeal)	19
9 - Others	20
4. Installation	21
4.1. General directions	21
4.2. Installation / surrounding conditions	21
4.3. Dimensions- Enclosure	22
4.4. Installing the hardware.....	24
4.4.1. Introduction	24
4.4.2. Voltage selection sensor supply	25
4.4.3. Terminal connectors	26
5. Intrinsically safe applications.....	33
5.1. General information and instructions	33
5.2. Terminal connectors Intrinsically Safe applications	34
5.3. Configuration examples Intrinsically Safe applications.....	36
5.4. Battery replacement instructions.....	38
6. Maintenance.....	39
6.1. General directions	39
Appendix A: Technical specification	40
Appendix B: Problem solving.....	43
Appendix C: Communication variables.....	44
Index of this manual.....	46
List of figures in this manual	46
Notes	47

1. INTRODUCTION

1.1. SYSTEM DESCRIPTION OF THE F153-A

Functions and features

The pressure indicator model F153-A is a microprocessor driven instrument designed to display the pressure as well as monitoring the pressure with four alarm values for a low-low, low, high and high-high pressure. This product has been designed with a focus on:

- ultra-low power consumption to allow long-life battery powered applications (type PB),
- intrinsic safety for use in hazardous applications (type XI),
- several mounting possibilities with aluminum or GRP enclosures for harsh industrial surroundings,
- ability to process all types of pressure signals,
- transmitting possibilities with analog, alarm relay and communication (type) outputs.

Sensor input

This manual describes the unit with one analog (0)4-20mA input for the pressure sensor "-A version" An other version is available to process 0-10V signal. To power the sensor, several options are available.

Standard outputs

- Configurable alarm outputs: two, three or four alarm outputs, depending on the unit ordered. The functionality of the output can be user defined.
- Configurable linear (0)4-20mA or 0-10V analog output with 10-bits resolution mirroring the actual pressure. Range as well as the minimum and maximum signal output can be tuned.

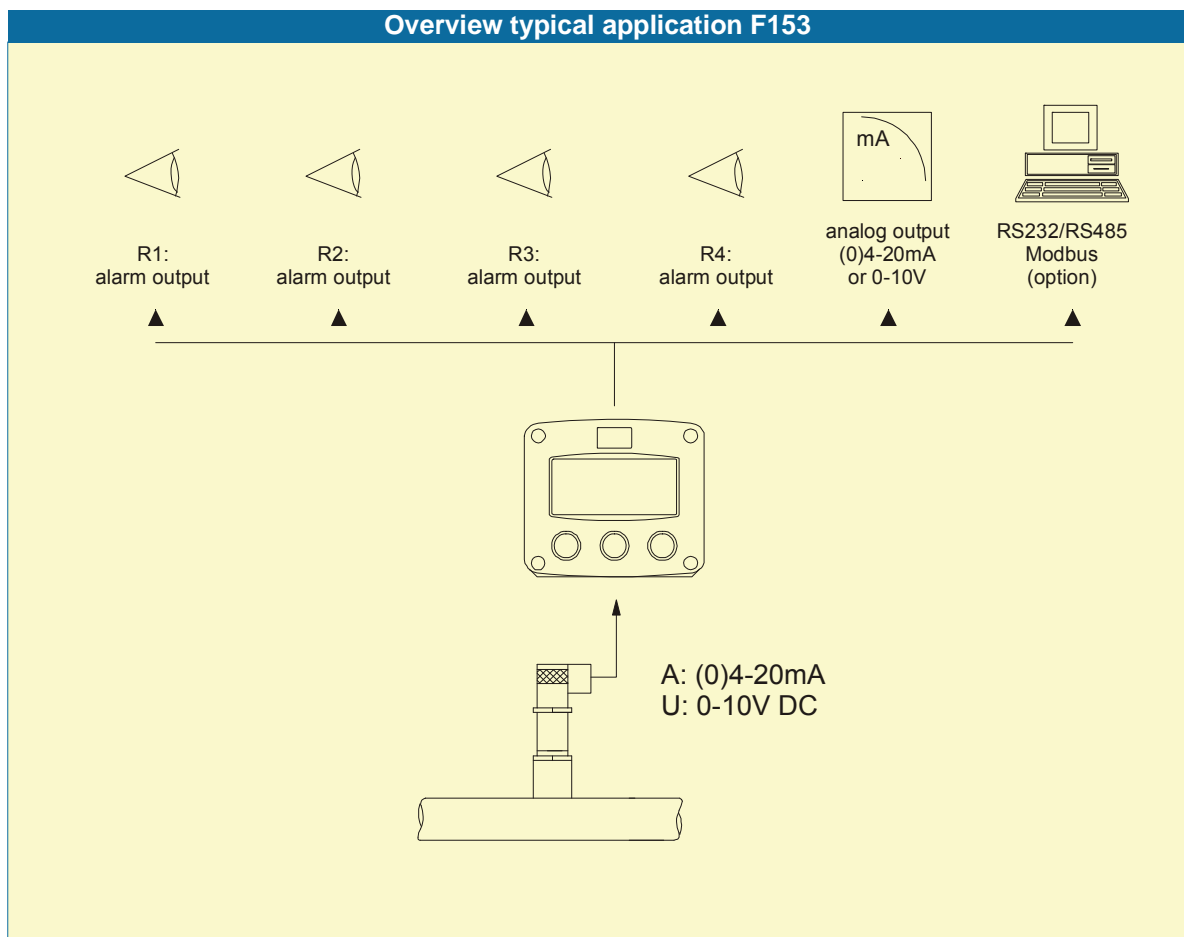

Fig. 1: Typical application for the F153-A.

Configuration of the unit

The F153-A was designed to be implemented in many types of applications. For that reason, a SETUP-level is available to configure your F153-A according to your specific requirements. SETUP includes several important features, such as Span, measurement units, signal settings etc. All settings are stored in EEPROM memory and will not get lost in case of power break-down or empty battery.

To extend the battery-life time (Type), please make use of the power-management functions as described in chapter 3.2.3.

Display information

The unit has a large transfective LCD with all kinds of symbols and digits to display measuring units, status information, trend-indication and key-word messages.

Options

Following options are available: isolated or active 4-20mA / 0-10V / 0-20mA analog output, full Modbus communication RS232/485 (also battery powered), intrinsic safety, mechanic relays or active outputs, power- and sensor-supply Types, panel-mount, wall-mount and weather-proof enclosures, flame proof enclosure.



Note !

Important

The number of alarm outputs is related to the options ordered:

Type PD - with 8-30V AC/DC: three outputs

Type PF - with 24 V AC/DC mains supply: three outputs

Type PM - with 80-230V mains supply: three outputs

Type PX - with type AP output loop powered: three outputs

Type XI - Intrinsically safe: two outputs

Type OS - relay board with 24V AC/DC mains supply: four relays.

2. OPERATIONAL

2.1. GENERAL



- *The F153-A may only be operated by personnel who are authorized and trained by the operator of the facility. All instructions in this manual are to be observed.*
- *Take careful notice of the " Safety rules, instructions and precautionary measures " in the front of this manual.*

This chapter describes the daily use of the F153-A. This instruction is meant for users / operators.

2.2. CONTROL PANEL

The following keys are available:

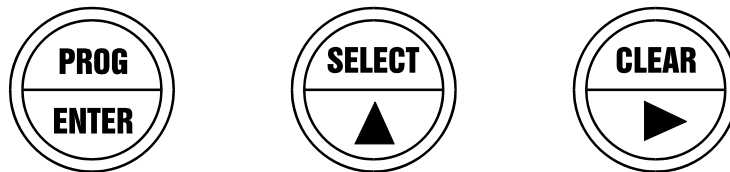

Fig. 2: Control Panel.

Functions of the keys



This key is used to program and save new values or settings.
It is also used to get access to SETUP-level; please read chapter 3.



This key is used to SELECT other display information or to increase a value.
The arrow-key \blacktriangle is used to configure the unit; please read chapter 3.



This key is used to SELECT other display information or to select a digit.
The arrow-key \blacktriangleright is used to configure the unit; please read chapter 3.

2.3. OPERATOR INFORMATION AND FUNCTIONS

In general, the F153-A will always act function at Operator-level. The information displayed is dependant up on the SETUP-settings. The sensor signal will be measured by the F153-A in the background, whichever screen refresh rate setting is chosen. After pressing a key, the display will be updated very quickly during a 30 second period, after which it will slow-down again.



Fig. 3: Example of display information during process.

For the Operator, the following functions are available:

- **Display pressure:**
 This is the main display information of the F153-A. After selecting any other information, it will always return to this main display automatically. The actual pressure is displayed with 17mm digits on the upper line. On the bottom line, the measuring unit will be displayed. When "-----" is shown, then the pressure value is too high to be displayed. The arrows \blacktriangle indicate the increase/decrease of the pressure trend.

- **Programming the high / low pressure alarm values:**

Remark: this function might not be accessible: it depends on the configuration of the unit..

When the SELECT-key is pressed a few times, the alarm values for low and high pressure will be displayed. To change the alarm value, following procedure must be execute:

- 1) press PROG: the word "PROGRAM" will be flashing,
- 2) use \blacktriangleright to select the digits and \blacktriangle to increase that value,
- 3) set the new alarm value by pressing ENTER.



Fig. 4: Example display information during programming maximum pressure.

When data is altered but ENTER has not been pressed yet, then the alteration can still be cancelled by waiting for 20 seconds or by pressing ENTER for a few seconds: the former value will be reinstated.

- ◆ Pressure alarm:
When the actual pressure is outside the allowed range, an alarm message will be displayed at the bottom line of the display indicating the type of alarm: "LO PRESS ", "HI PRESS" or "HI-LO PRESS".
The alarm is terminated automatically as soon as the pressure is in its range again. Due to the setup configuration it might be that the pressure is outside it's range without an immediate alarm.
- **Low-battery alarm**
When the battery voltage drops, it must be replaced. At first "low-battery" will flash, but as soon as it is displayed continuously, the battery **MUST** be replaced shortly after!
Only original batteries supplied by the manufacturer may be used, else the guarantee and liability will be terminated. The remaining lifetime after the first moment of indication is generally several days up to some weeks.



Fig. 5: Example of low-battery alarm.

- ◆ Alarm 01-04:
When "alarm" is displayed, please consult Appendix B: problem solving.

3. CONFIGURATION

3.1. INTRODUCTION

This and the following chapters are exclusively meant for electricians and non-operators. In these, an extensive description of all software settings and hardware connections are provided.



- *Mounting, electrical installation, start-up and maintenance of the instrument may only be carried out by trained personnel authorized by the operator of the facility. Personnel must read and understand this Operating Manual before carrying out its instructions.*
- *The F153-A may only be operated by personnel who are authorized and trained by the operator of the facility. All instructions in this manual are to be observed.*
- *Ensure that the measuring system is correctly wired up according to the wiring diagrams. The housing may only be opened by trained personnel.*
- *Take careful notice of the " Safety rules, instructions and precautionary measures " in the front of this manual.*

3.2. PROGRAMMING SETUP-LEVEL

3.2.1. GENERAL

Configuration of the F153-A is done at SETUP-level. SETUP-level is reached by pressing the PROG/ENTER key for 7 seconds; at which time, both arrows \blacktriangle will be displayed. In order to return to the Operator-level, PROG will have to be pressed for three seconds. Alternatively, if no keys are pressed for 2 minutes, the unit will exit SETUP automatically. SETUP can be reached at all times while the F153-A remains fully operational.



Note: A password may be required to enter SETUP. Without this password access to SETUP is denied.

To enter SETUP-level:

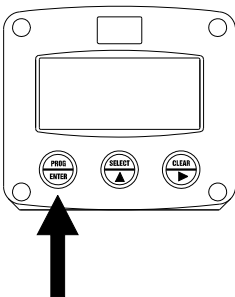

Press  for 7 seconds

Matrix structure SETUP-level:

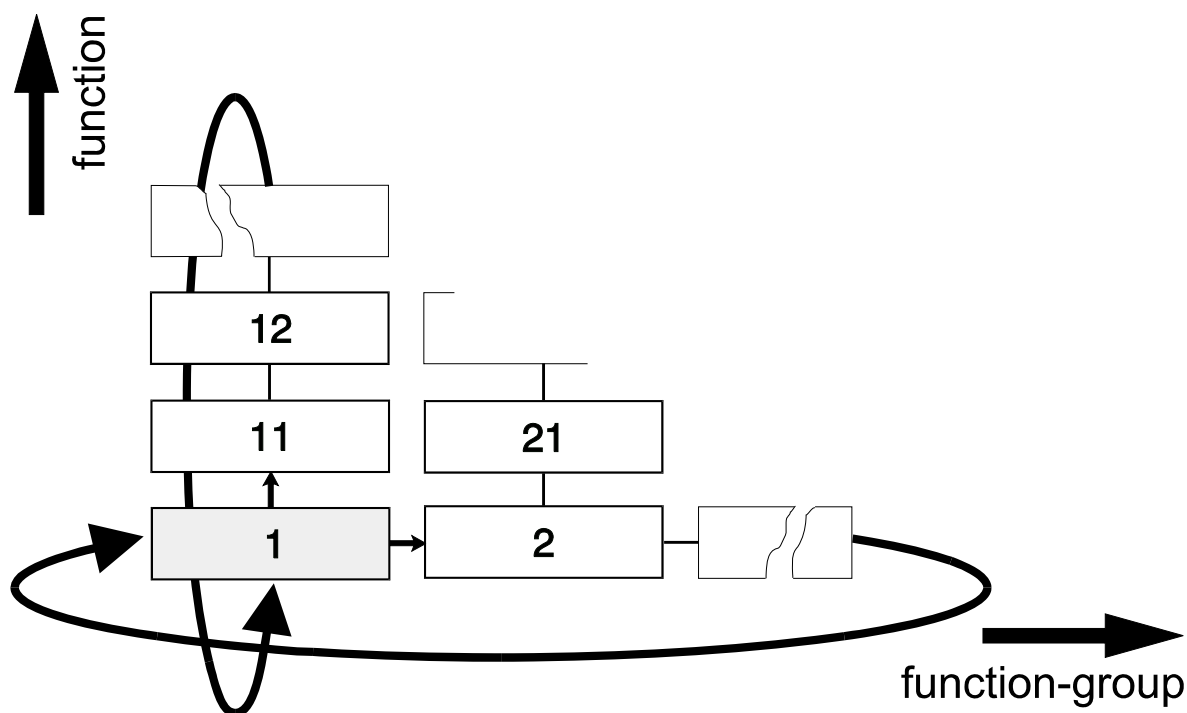

SCROLLING THROUGH SETUP-LEVEL

Selection function-group and function:

SETUP is divided into several function groups and functions.

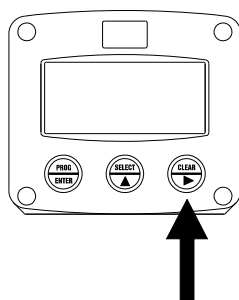

Select function-group with

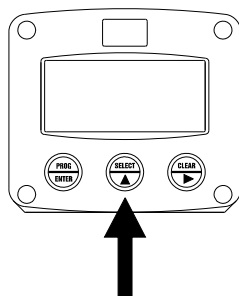

Select function with







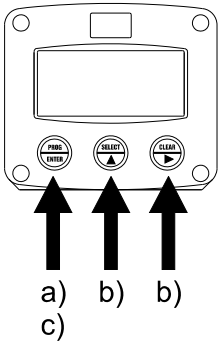

Each function has a unique number, which is displayed below the word "SETUP" at the bottom of the display. The number is a combination of two figures. The first figure indicates the function-group and the second figure the function. Additionally, each function is expressed with a keyword.



After selecting a sub-function, the next main function is selected after scrolling through all "active" sub-functions (e.g. 1[▲], 11[▲], 12[▲], 13[▲], 14[▲], 1[▶], 2[▶], 3[▲], 31 etc.).



To change or a select a value or value:



- a) press  briefly; **PROGRAM** will start flash
- b) select or enter value with  and / or 
- c) press  to confirm the value / selection.

To change a value, use  to select the digits and  to increase that value.

To select a setting, both  and  can be used.

When the new value is not valid, the increase sign  or decrease-sign  will be displayed while you are programming.

When data is altered but ENTER is not pressed, then the alteration can still be cancelled by waiting for 20 seconds or by pressing ENTER for three seconds: the PROG-procedure will be left automatically and the former value reinstated.



Note: alterations will only be set after ENTER has been pressed!

To return to Operator-level:

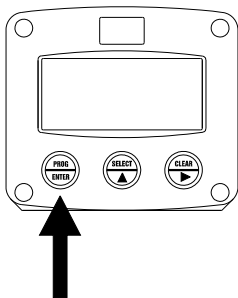

Press  for 3 seconds

In order to return to the Operator-level, PROG will have to be pressed for three seconds. Also, when no keys are pressed for 2 minutes, SETUP will be left automatically.

3.2.2. OVERVIEW FUNCTIONS SETUP-LEVEL

SETUP FUNCTIONS AND VARIABLES			
1	PRESSURE		
	11	UNIT	mbar - bar - psi - no unit
	12	DECIMALS	0 - 1 - 2 - 3 (Ref: displayed value)
	13	SPAN	0.000001 - 999,999 units
	14	DECIMALS SPAN	0 - 6
	15	OFFSET	-999,999 - +999,999 units
2	ALARM		
	21	OFFSET	default - no relays - ignore
	22	ALARM LOW-LOW	0000.000 - 9,999,999
	23	ALARM LOW	0000.000 - 9,999,999
	24	ALARM HIGH	0000.000 - 9,999,999
	25	ALARM HIGH-HIGH	0000.000 - 9,999,999
	26	DELAY ALARM low-low	0.1 - 999.9 seconds
	27	DELAY ALARM LOW	0.1 - 999.9 seconds
	28	DELAY ALARM HIGH	0.1 - 999.9 seconds
	29	DELAY ALARM high-high	0.1 - 999.9 seconds
3	DISPLAY		
	31	ALARM SET	operator - setup
4	POWER MANAGEMENT		
	41	LCD UPDATE	fast - 1 sec - 3 sec - 15 sec - 30 sec - off
	42	BATTERY MODE	operational - shelf
5	SENSOR		
	51	FILTER	00 - 99
	52	CUT-OFF	0.0 - 99.9%
	53	CALIBRATE LOW	(0)4mA
	54	CALIBRATE HIGH	20mA
6	ANALOG		
	61	OUTPUT	disable - enable
	62	PRESSURE MINIMUM	-999,999 - +999,999 unit
	63	PRESSURE MAXIMUM	-999,999 - +999,999 unit
	64	CUT-OFF	0.0 - 9.9%
	65	TUNE MIN - 0/4mA / 0V	0 - 9,999
	66	TUNE MAX- 20mA / 10V	0 - 9,999
	67	FILTER	00 - 99
7	RELAYS		
	71	OUTPUT R1	low-low - low - high - high-high - all - off
	72	OUTPUT R2	low-low - low - high - high-high - all - off
	73	OUTPUT R3	low-low - low - high - high-high - all - off
	74	OUTPUT R4	low-low - low - high - high-high - all - off
8	COMMUNICATION		
	81	SPEED / BAUDRATE	1200 - 2400 - 4800 - 9600
	82	ADDRESS	1 - 255
	83	MODE	RTU - off
9	OTHERS		
	91	TYPE / MODEL	F153-A
	92	SOFTWARE VERSION	
	93	SERIAL NO.	
	94	PASSWORD	0000 - 9999
	95	TAGNUMBER	0000000 - 9999999

3.2.3. EXPLANATION SETUP-FUNCTIONS

1 - PRESSURE	
MEASUREMENT UNIT 11	<p>SETUP - 11 determines the measurement unit for pressure measured .</p> <p>The following units can be selected:</p> <p style="text-align: center;">mbar - bar - psi - no unit</p> <p>Alteration of the measurement unit will have consequences for operator and SETUP-level values. Please note that the Span has to be adapted as well; the calculation is not done automatically.</p>
DECIMALS 12	<p>This setting determines for pressure the number of digits following the decimal point. The following can be selected:</p> <p style="text-align: center;">00000 - 1111.1 - 2222.22 - 3333.333</p>
SPAN 13	<p>With the span, the sensor signal is converted to a pressure. The span for pressure is determined on the basis of the selected measurement unit at 20mA. Enter the span in whole numbers (decimals are set with SETUP 14). The more accurate the span, the more accurate the functioning of the system will be.</p> <p>Example 1 Calculating the span for pressure <i>Let us assume that the sensor generates 20mA at a pressure of 18.95 Bar and the selected unit is "mbar". The span is 18,950 mbar, Enter for SETUP - 13: "18950" and for SETUP - 14 - decimals span "0".</i></p>
DECIMALS SPAN 14	<p>This setting determines the number of decimals for Span (SETUP 13). The following can be selected:</p> <p style="text-align: center;">0 - 1 - 2 - 3 - 4 - 5 - 6</p> <p>Please note that this SETUP - influences the accuracy of the Span indirectly. This setting has NO influence on the displayed number of digits for "pressure" (SETUP 12)!</p>
OFF SET 15	<p>Enter here the "not measured" pressure, in case a pressure transducer is not placed in the bottom of a container but somewhere halfway for example. Also, a negative offset can be entered: do press the middle and left button simultaneously.</p>



Note !

2 - ALARM

With these settings, it is determined how the pressure will be monitored and the functionality of the transistor / relay outputs be determined.

Please be aware that the alarm levels can be programmed at Operator-level as well. Moreover, the function be locked (setup 31).

Note: for transistor / relay output functions: read *SETUP 7 "relays"*.

OFFSET 21	When the pressure is according to the <u>offset value</u> - setup 15 (most cases zero), then it is possible to ignore or disable the pressure monitoring. The following settings can be selected: DEFAULT: in case of a low-pressure alarm and pressure zero, it will switch the alarm output and indicate the alarm on the display. NO RELAY: in case of a low-pressure alarm and pressure zero, it won't switch the alarm output but will indicate the alarm on the display only. IGNORE: in case of a low-pressure alarm and pressure zero, it won't switch the alarm output and nothing will be indicated on the display.
ALARM VALUE LOW - LOW 22	The low-low alarm is set with this setting. An alarm will be generated as long as the pressure is lower as this value. With value 0.0 this function is disabled.
ALARM VALUE LOW 23	The low alarm is set with this setting. An alarm will be generated as long as the pressure is lower as this value. With value 0.0 this function is disabled.
ALARM VALUE HIGH 24	The high alarm is set with this setting. An alarm will be generated as long as the pressure is higher as this value. With value 0.0 this function is disabled.
ALARM VALUE HIGH - HIGH 25	The high-high alarm is set with this setting. An alarm will be generated as long as the pressure is higher as this value. With value 0.0 this function is disabled.
DELAY TIME ALARM LOW - LOW 26	An alarm generated by SETUP 22 "low-low" can be ignored during X-time period. If the actual pressure is still incorrect after this delay time, then an alarm will be generated.
DELAY TIME ALARM LOW 27	An alarm generated by SETUP 23 "low" can be ignored during X-time period. If the actual pressure is still incorrect after this delay time, then an alarm will be generated.
DELAY TIME ALARM HIGH 28	An alarm generated by SETUP 24 "high" can be ignored during X-time period. If the actual pressure is still incorrect after this delay time, then an alarm will be generated.
DELAY TIME ALARM HIGH - HIGH 29	An alarm generated by SETUP 25 "high-high" can be ignored during X-time period. If the actual pressure is still incorrect after this delay time, then an alarm will be generated.

3 - DISPLAY

ALARM SET 31	With this function it is determined if the operator can enter alarm values or not. If "SETUP" is selected, the operator is still able to read the values but can not change them.
-------------------------------	---

4 - POWER MANAGEMENT

When used with the internal battery Type, the user may hold the concern of reliable measurement over a long period of time. The F153-A has several smart power management functions to extend the battery life time significantly. Two of these functions can be set:

LCD NEW 41	<p>The calculation of the display-information influences the power consumption significantly. When the application does not require a fast display update, it is strongly advised to select a slow refresh-rate. Please understand that NO information will be lost; the signal will be processed and the output-signals will be generated in the normal way. The following can be selected:</p> <p style="text-align: center;">Fast - 1 sec - 3 sec - 15 sec - 30 sec - off.</p> <p>Example 3: Battery life-time <i>battery life-time with FAST update: about 1 years.</i> <i>battery life-time with 1 sec update: about 3 years.</i></p> <p>Note: after a button has been pressed by the operator - the display refresh-rate will always be FAST during 30 seconds. When "OFF" is selected, the display will be switched-off after 30 seconds and will be switched-on as soon as a button has been pressed.</p>
BATTERY-MODE 42	<p>The unit has two modes: operational or shelf. After "shelf" has been selected, the unit can be stored for several years; it will not process the signal, the display is switched-off but all settings and totals are stored. In this mode, power consumption is extremely low. To wake-up the unit again; press the SELECT-key twice.</p>



Note !

5 - SENSOR

FILTER 51	<p>The analog output signal of a sensor does mirror the actual pressure. This signal is measured several times a second by the F153-A. The value measured is a "snap-shot" of the real pressure as it will be fluctuating. With the help of this digital filter a stable and accurate reading can be obtained while the filter pressure can be set to a desired value.</p> <p>The filter principal is based on three input values: the filter pressure (01-99), the last measured analog value and the last average value. The higher the filter pressure, the longer the response time on a value change will be. Below, several filter pressures with there response times are indicated:</p>
----------------------------	---

FILTER VALUE	RESPONSE TIME ON STEP CHANGE OF ANALOG VALUE.			
	TIME IN SECONDS			
	50% INFLUENCE	75% INFLUENCE	90% INFLUENCE	99% INFLUENCE
01	filter disabled	filter disabled	filter disabled	filter disabled
02	0.3 seconds	0.5 seconds	1.0 seconds	1.8 seconds
03	0.5 seconds	1.0 seconds	1.5 seconds	3 seconds
05	1.0 seconds	1.8 seconds	2.8 seconds	5.3 seconds
10	1.8 seconds	3.5 seconds	5.6 seconds	11 seconds
20	3.5 seconds	7.0 seconds	11 seconds	23 seconds
30	5.3 seconds	10 seconds	17 seconds	34 seconds
50	8.8 seconds	17 seconds	29 seconds	57 seconds
75	13 seconds	26 seconds	43 seconds	86 seconds
99	17 seconds	34 seconds	57 seconds	114 seconds

Continued next page >>>

5 - SENSOR (CONTINUED)

CUT-OFF 52	<p>To ignore e.g. vibration, a low-pressure cut-off can be set as percentage over the full range of 16mA (or 20mA / 10V). When the analog value is less then required with this setting, the signal will be ignored. The cut-off value can be programmed is the range 0.0 - 99.9%.</p> <p>Examples:</p>			
	SPAN (setup 13)	REQUIRED CUT-OFF	CUT-OFF (setup 52)	REQUIRED OUTPUT
	450 PSI	25 PSI	$25/450 \times 100\% = 5.5\%$	$16\text{mA} \times 5.5\% + 4\text{mA} = 4.88\text{mA}$
TUNE MIN / 4MA 53	<p>With this setting it is possible to calibrate the input value for (0)4mA as the signal from the sensor might not be exact 4.0 mA (or 0.0 mA) at pressure zero. This function will measure the real output value at pressure zero.</p> <ul style="list-style-type: none"> ▪ <i>Warning: be very sure that the offered signal is correct before the calibration is executed as this function has major influences on the accuracy of the system!</i> <p>After pressing PROG, three settings can be selected:</p> <ul style="list-style-type: none"> ▪ CALIBRATE: with this setting, the input will be calibrated with the actual "(0)4mA" value. After pressing enter, CAL SET will be displayed as soon as the calibration is completed. From that moment, the analog value must be more than the calibrated value before the signal will be processed. ▪ DEFAULT: with this setting, the manufactures value is re-installed. ▪ CAL SET: to select the last calibrated value. 			
TUNE MAX / 20MA 54	<p>With this setting it is possible to calibrate the input value for 20mA as the signal from the sensor might not be exact 20.0 mA at maximum pressure. This function will measure the real output value at maximum pressure.</p> <ul style="list-style-type: none"> ▪ <i>Warning: be very sure that the offered signal is correct before the calibration is executed as this function has major influences on the accuracy of the system!</i> <p>After pressing PROG, three settings can be selected:</p> <ul style="list-style-type: none"> ▪ CALIBRATE: with this setting, the input will be calibrated with the actual "20mA" value. After pressing enter, CAL SET will be displayed as soon as the calibration is completed. From that moment, the analog value must be less than the calibrated value for a reliable measurement. ▪ DEFAULT: with this setting, the manufactures value is re-installed. ▪ CAL SET: to select the last calibrated value. 			



6 - ANALOG OUTPUT

A linear 4-20mA signal (Type AB: 0-20mA or Type AU: 0-10V) output signal is generated according to the calculated pressure with a 10 bits resolution. The settings for pressure (SETUP - 1) influences the analog output directly.

Note: When the analog-output is not used, please make sure that setting 61 is disabled, else the battery life-time will be reduced significantly!

When a power supply is available but the output is disabled, a 3.5mA signal will be generated.

The relationship between rate and analog output is set with following functions:



DISABLE / ENABLE 61	The analog output can be disabled. In case of a passive analog output type AP, 3.5mA will be generated if a power supply is available but the output is disabled.
--------------------------------------	--

MINIMUM PRESSURE 62	Enter here the pressure according which the output should generate a 4mA signal (or 0mA / 0V) - in most applications at pressure "zero". The number of decimals displayed is according to SETUP 12. The measuring units (PSI for example) is according SETUP 11 but can not be displayed.
--------------------------------------	---

MAXIMUM PRESSURE 63	Enter here the pressure according which the output should generate a 20mA (or 10V) - in most applications at maximum pressure. The number of decimals displayed is according to SETUP 12. The measuring units (PSI for example) is according SETUP 11 but can not be displayed.
--------------------------------------	---

CUT-OFF 64	A low-pressure cut-off can be set as percentage over the full range of 16mA (or 20mA / 10V). When the pressure is less as required, the current will be 4mA. Examples:
-----------------------------	---

4mA (SETUP 62)	20mA (SETUP 63)	CUT-OFF (SETUP 64)	REQUIRED RATE	OUTPUT
0 PSI	100 PSI	2%	$(100-0)*2\% = 2.0 \text{ PSI}$	$4+(16*2\%) = 4.32\text{mA}$
20 PSI	800 PSI	3.5%	$(800-20)*3.5\% = 27.3 \text{ PSI}$	$4+(16*3.5\%)=4.56\text{mA}$

TUNE MIN / 4MA 65	<p>The initial minimum analog output value is 0/4mA or 0V. However, this value might differ slightly due to external influences such as temperature for example. The 0/4mA or 0V value can be tuned precisely with this setting.</p> <ul style="list-style-type: none"> ▪ <i>Before tuning the signal, be sure that the analog signal is not being used for any application!</i> <p>After pressing PROG, the current will be about 4mA (or 0mA / 0V). The current can be increased / decreased with the arrow-keys and is <u>directly active</u>. Press ENTER to store the new value. Remark: the analog output value can be programmed "up-side-down" if desired, so 20mA at minimum pressure for example!</p>
------------------------------------	---



TUNE MAX / 20MA 66	<p>The initial maximum analog output value is 20mA (or 10V). However, this value might differ slightly due to external influences such as temperature for example. The 20mA value (or 10V) can be tuned precisely with this setting.</p> <ul style="list-style-type: none"> ▪ <i>Before tuning the signal, be sure that the analog signal is not being used for any application!</i> <p>After pressing PROG, the current will be about 20mA. The current can be increased / decreased with the arrow-keys and is <u>directly active</u>. Press ENTER to store the new value. Remark: the analog output value can be programmed "up-side-down" if desired, so 4mA at maximum pressure for example!</p>
-------------------------------------	---



Continued next page >>>

6 - ANALOG OUTPUT (CONTINUED)

FILTER 67	This function is used to stabilize the analog output signal. The output value is update every 0.1 second. With the help of this digital filter a more stable but less actual reading can be obtained. The filter principal is based on three input values: the filter pressure (01-99), the last analog output value and the last average value. The higher the filter pressure, the longer the response time on a value change will be. Below, several filter pressures with there response times are indicated:			
FILTER VALUE	RESPONSE TIME ON STEP CHANGE OF ANALOG VALUE. TIME IN SECONDS			
	50% INFLUENCE	75% INFLUENCE	90% INFLUENCE	99% INFLUENCE
01	filter disabled	filter disabled	filter disabled	filter disabled
02	0.1 second	0.2 second	0.4 second	0.7 second
03	0.2 second	0.4 second	0.6 second	1.2 seconds
05	0.4 second	0.7 second	1.1 seconds	2.1 seconds
10	0.7 second	1.4 seconds	2.2 seconds	4.4 seconds
20	1.4 seconds	2.8 seconds	4.5 seconds	9.0 seconds
30	2.1 seconds	4 seconds	7 seconds	14 seconds
50	3.5 seconds	7 seconds	11 seconds	23 seconds
75	5.2 seconds	10 seconds	17 seconds	34 seconds
99	6.9 seconds	14 seconds	23 seconds	45 seconds



Note !

7 - RELAY OUTPUT

With "SETUP 2", four alarm pressures can be entered. Based on the options ordered, the F153-A will have 2, 3 or 4 alarm outputs.

Note: If the unit is Intrinsically Safe, it will have two alarm outputs. If Type ZR (relay board) has been supplied, it will have four alarm outputs. Else it has three alarm outputs.

OUTPUT R1 71	Assign the output function to output R1. Following can be selected: low-low - low - high - high-high alarm - all alarms - off
OUTPUT R2 72	Assign the output function to output R2. Following can be selected: low-low - low - high - high-high alarm - all alarms - off
OUTPUT R3 73	Assign the output function to output R3. Following can be selected: low-low - low - high - high-high alarm - all alarms - off
OUTPUT R4 74	Assign the output function to output R4. Following can be selected: low-low - low - high - high-high alarm - all alarms - off

8 - COMMUNICATION (TYPEAL)

Functions as described below deal with hardware that are not part of the standard delivery. Programming of these functions does not have any effect if this hardware has not been installed. Consult Appendix C and the Modbus communication protocol description for a detailed explanation.

BAUDRATE 81	For external control, following communication speeds can be selected: 1200 - 2400 - 4800 - 9600 baud
BUS ADDRESS 82	For communication purposes, a unique identity can be attributed to every F153-A. This address can vary from 1-255.
MODE 83	The communication is executed according Modbus protocol RTU mode. With OFF, the communication is disabled.

9 - OTHERS	
TYPE OF MODEL 91	For support and maintenance it is important to have information about the characteristics of the F153-A. Your supplier will ask for this information in the case of a serious breakdown or to assess the suitability of your model for upgrade considerations.
VERSION SOFTWARE 92	For support and maintenance it is important to have information about the characteristics of the F153-A. Your supplier will ask for this information in the case of a serious breakdown or to assess the suitability of your model for upgrade considerations.
SERIAL NUMBER 93	For support and maintenance it is important to have information about the characteristics of the F153-A. Your supplier will ask for this information in the case of a serious breakdown or to assess the suitability of your model for upgrade considerations.
PASSWORD 94	All SETUP-values can be password protected. This protection is disabled with value 0000 (zero). Up to and including 4 digits can be programmed, for example 1234.
TAGNUMBER 95	For identification of the unit and communication purposes, a unique tagnumber of maximum 7 digits can be entered.

4. INSTALLATION



4.1. GENERAL DIRECTIONS

- Mounting, electrical installation, start-up and maintenance of this instrument may only be carried out by trained personnel authorized by the operator of the facility. Personnel must read and understand this Operating Manual before carrying out its instructions.
- The F153-A may only be operated by personnel who are authorized and trained by the operator of the facility. All instructions in this manual are to be observed.
- Ensure that the measuring system is correctly wired up according to the wiring diagrams. Protection against accidental contact is no longer assured when the housing cover is removed or the panel cabinet has been opened (danger from electrical shock). The housing may only be opened by trained personnel.
- Take careful notice of the " Safety rules, instructions and precautionary measures " at the front of this manual.

4.2. INSTALLATION / SURROUNDING CONDITIONS

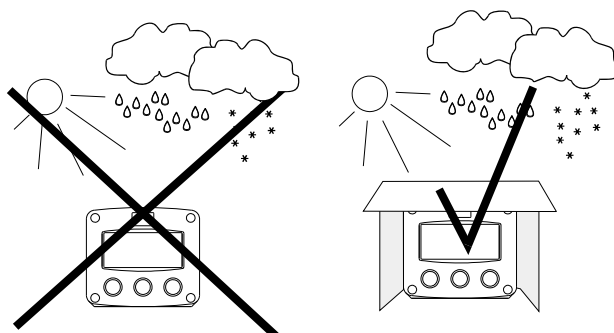

Take the relevant IP classification of the casing into account (see manufactures plate). Even an IP67 (NEMA 4X) casing should NEVER be exposed to strongly varying (weather) conditions.

When panel-mounted, the unit is IP65 (NEMA 4X)!

When used in very cold surroundings or varying climatic conditions, take the necessary precautions against moisture by placing a dry sachet of silica gel, for example, inside the instrument case.

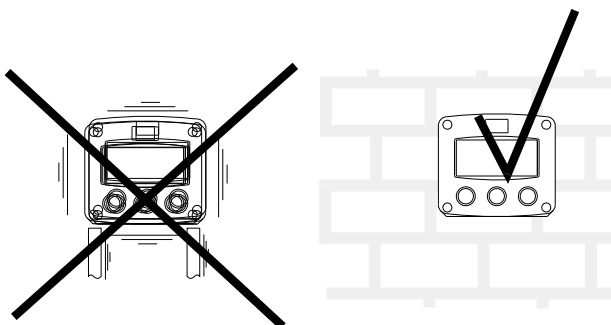

Mount the F153-A on a solid structure to avoid vibrations.

4.3. DIMENSIONS- ENCLOSURE

Aluminum enclosures:

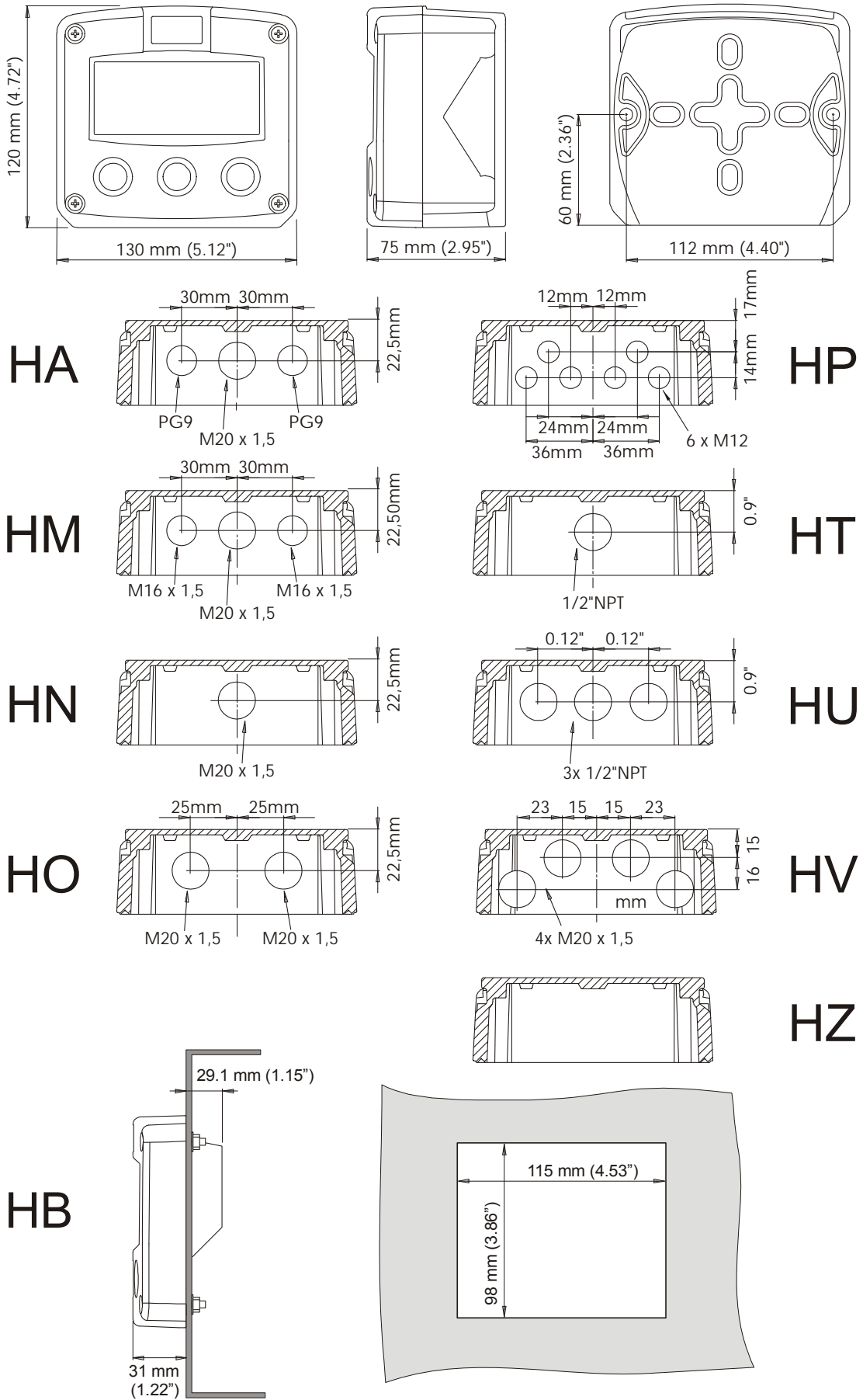
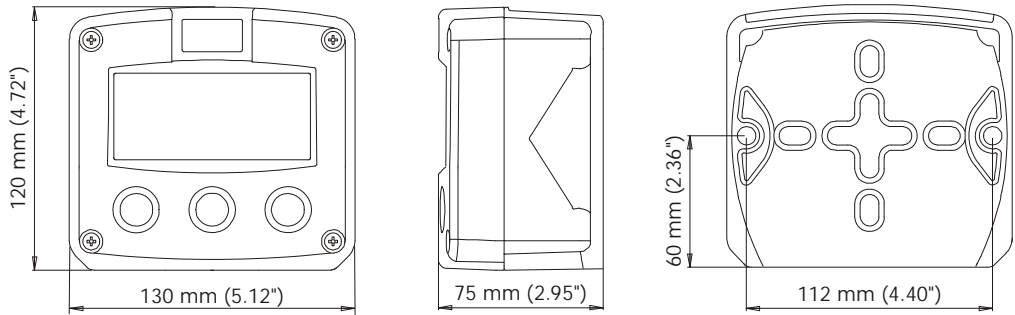
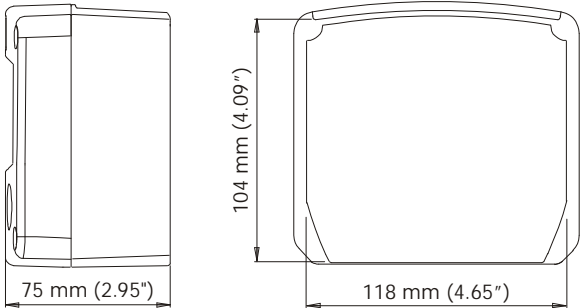

Fig. 6: Dimensions aluminum enclosures.

GRP enclosures:



HK back box:
(flat bottom)



HD
HK

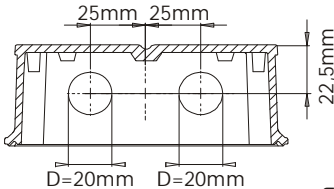
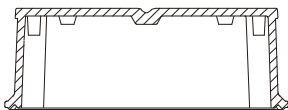

HG

HE

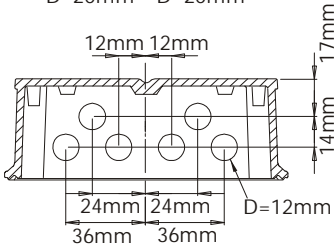
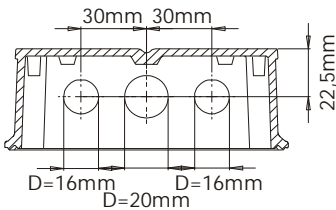

HH

HF

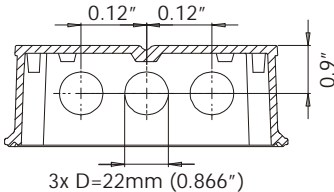
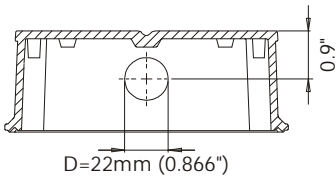

HJ

HC

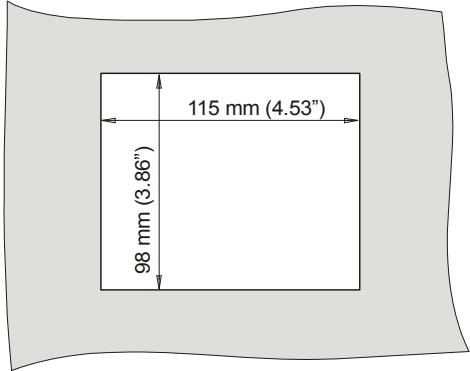
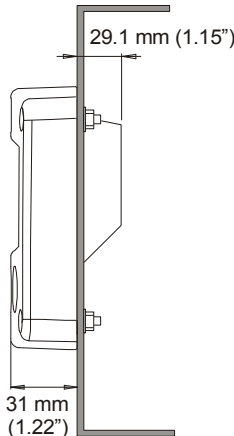

Fig 7: Dimensions GRP enclosures.

4.4. INSTALLING THE HARDWARE



4.4.1. INTRODUCTION

- Electro static discharge does inflict irreparable damage to electronics! Before installing or opening the unit, the installer has to discharge himself by touching a well-grounded object.
- This unit must be installed in accordance with the EMC guidelines (Electro Magnetic Compatibility).



Aluminum enclosures

- When installed in an aluminum enclosure and a potentially explosive atmosphere requiring apparatus of equipment protection level Ga and Da, the unit must be installed such that, even in the event of rare incidents, an ignition source due to impact or friction sparks between the enclosure and iron/steel is excluded.
- Do ground the aluminum enclosure properly as indicated, if the F153-A has been supplied with the 115-230V AC power-supply type PM. The green / yellow wire between the back-casing and removable terminal-block may never be removed.

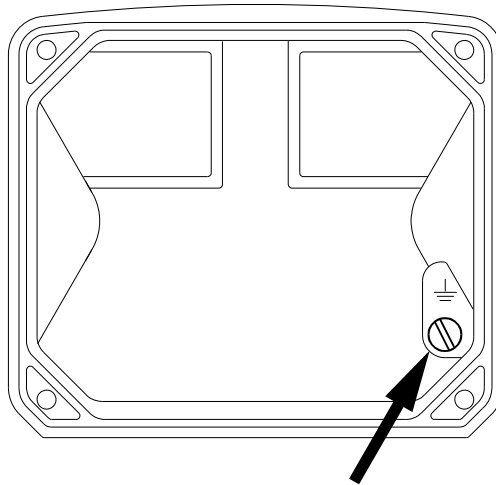

Fig. 8: Grounding aluminum enclosure with type PM 115-230V AC.

FOR INSTALLATION, PAY EMPHATIC ATTENTION TO:

- Separate cable glands with effective IP67 (NEMA4X) seals for all wires.
- Unused cable entries: ensure that you fit IP67 (NEMA4X) plugs to maintain rating.
- A reliable ground connection for both the sensor, and if applicable, for the metal casing.
- An effective screened cable for the input signal, and grounding of its screen to terminal 9 (GND) or at the sensor itself, whichever is appropriate to the application.

4.4.2. VOLTAGE SELECTION SENSOR SUPPLY

For Intrinsically Safe applications: read chapter 5.

Type PB / PC / PX (AP) - battery powered and output loop-powered applications:

Terminal 11 provides a limited supply voltage of 3.2 V DC for the signal output of the flowmeter. This is not suitable to power analog sensors.

Type PD / PF / PM: Sensor supply: 1.2 - 3.2V - 8.2V - 12V or 24 V DC:

With this option, a real power supply for the sensor is available. The flowmeter can be powered with 8.2 - 12 or 24 V DC.

Total power consumption PD: max. 50mA@24V and PF / PM: max. 400mA@24V.

The voltage is selected with the three switches inside the enclosure.



- **Warning: be sure that all the leads to the terminals are disconnected from the unit when the internal plastic protection cover has been removed !**
- **HIGH VOLTAGE 400V !! NEVER connect the mains power supply to the unit when the plastic protection cover has been removed !!!**

First, remove the terminal strip(s) after which the internal plastic cover can be removed. The switches are located in the top left corner (type PD) or on the right hand (type PF / PM) as indicated:

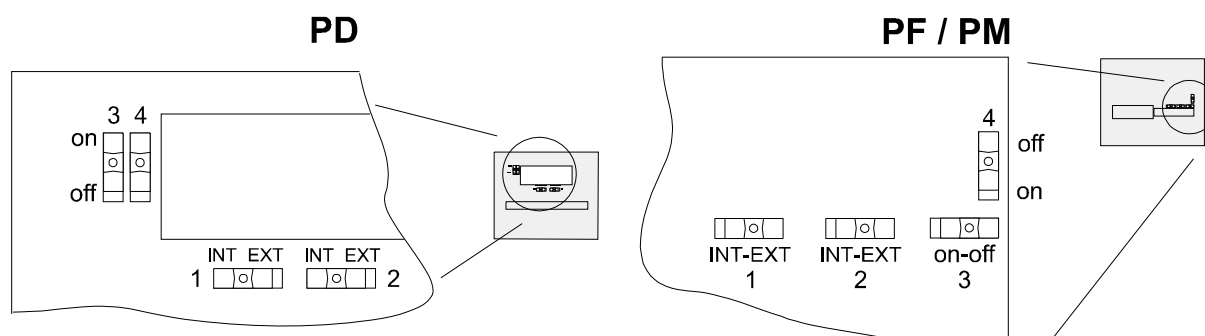

Fig. 9: Switch setting sensor supply voltage.

Switch positions

SENSOR A	
SWITCH 1	VOLTAGE
internal	3.2 V DC
external	switch 3+4

SENSOR B	

VOLTAGE SELECTION		
SWITCH 3	SWITCH 4	VOLTAGE
on	on	8.2 V DC
on	off	12 V DC
off	off	23 V DC

Function switch 1: voltage selection sensor A - terminal 11.

Function switch 2: not available.

Function switch 3+4: the combination of these switches determine the voltage as indicated. Do move switch 1 and / or switch 2 to the OFF position to enable the selected voltage with switch 3+4.

4.4.3. TERMINAL CONNECTORS

For Intrinsically Safe applications: read chapter 5.

The following terminal connectors are available:

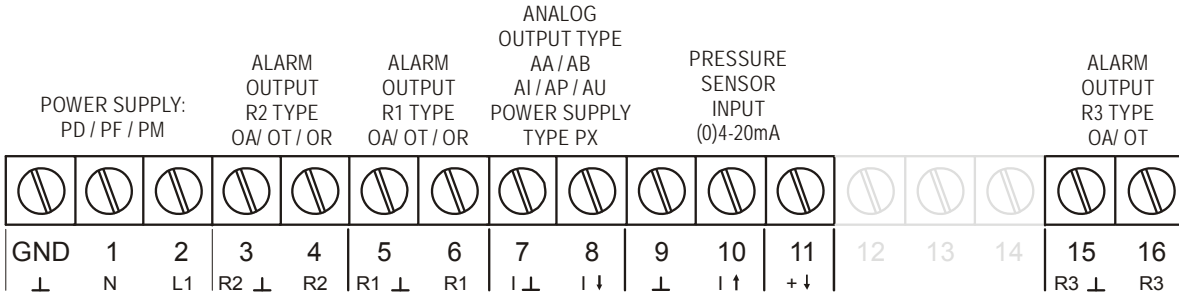

Fig. 10: Overview terminal connectors **standard** configuration F153-A and Types.

REMARKS TERMINAL CONNECTORS:

Terminal GND- 01- 02: Power Supply - only available with type PD / PF or PM:

TYPE	SENSOR SUPPLY	Terminal			backlight	TYPE AA	TYPE AU	Type OA	Type OR
		GND	01	02					
PD 8-24V AC	8,2-12-24V max. 50mA		AC	AC	◇	◇	◇		
PD 8-30V DC	8,2-12-24V max. 50mA	L-	L+		◇	◇	◇		
PF 24V AC ± 15%	8,2-12-24V max. 400mA		AC	AC	◇	◇		◇	
PF 24V DC ± 15%	8,2-12-24V max. 400mA	L-	L+		◇	◇		◇	
PM 115-230V AC ± 15%	8,2-12-24V max. 400mA	EARTH	AC	AC	◇	◇	◇	◇	
Note PD	do not use a AC autotransformer (Spartrafo) without a galvanic isolation.								
Note PF / PM	The total consumption of the sensors and outputs may not exceed 400mA@24V								

◇=option



Note !

Note: for power supply type PX: please read Terminal 07-08 !

Terminal 03-04; alarm output R2:

This output is an alarm output according setup 82.

Terminal 05-06; alarm output R1:

This output is an alarm output according setup 81.

Type OA:

An active 24V DC signal according the alarm settings is available with this option.

Max. driving capacity 50mA@24V per output. (Requires power supply Type PD / PF / PM).

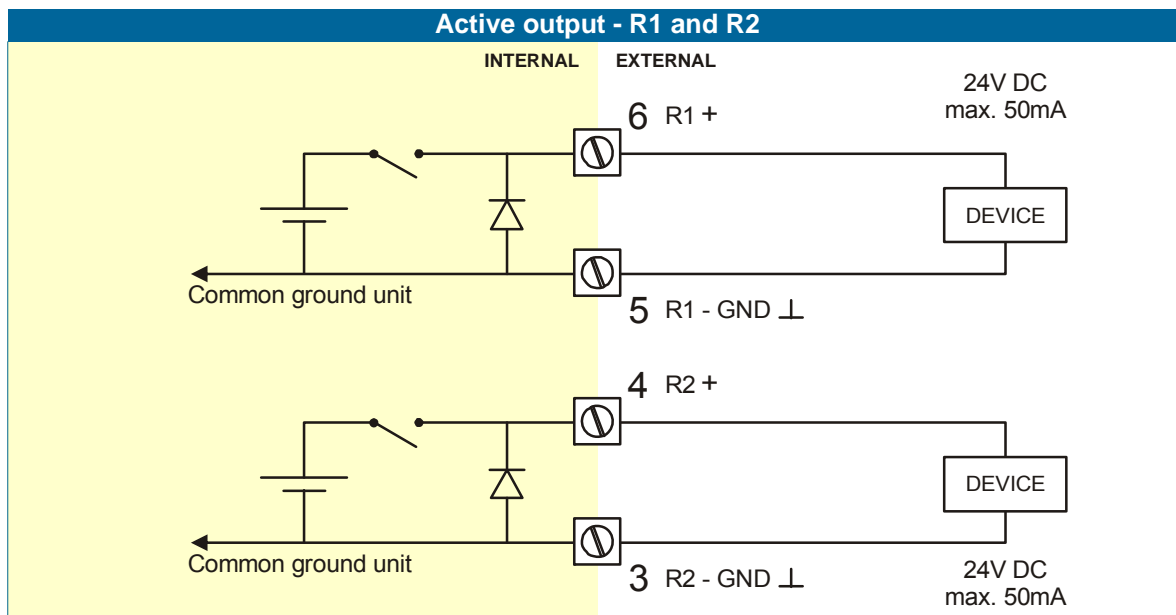

Type OR:

A mechanical relay output is available with this option.

Max. switch power 240V-0,5A per output. (Requires power supply Type PF / PM).

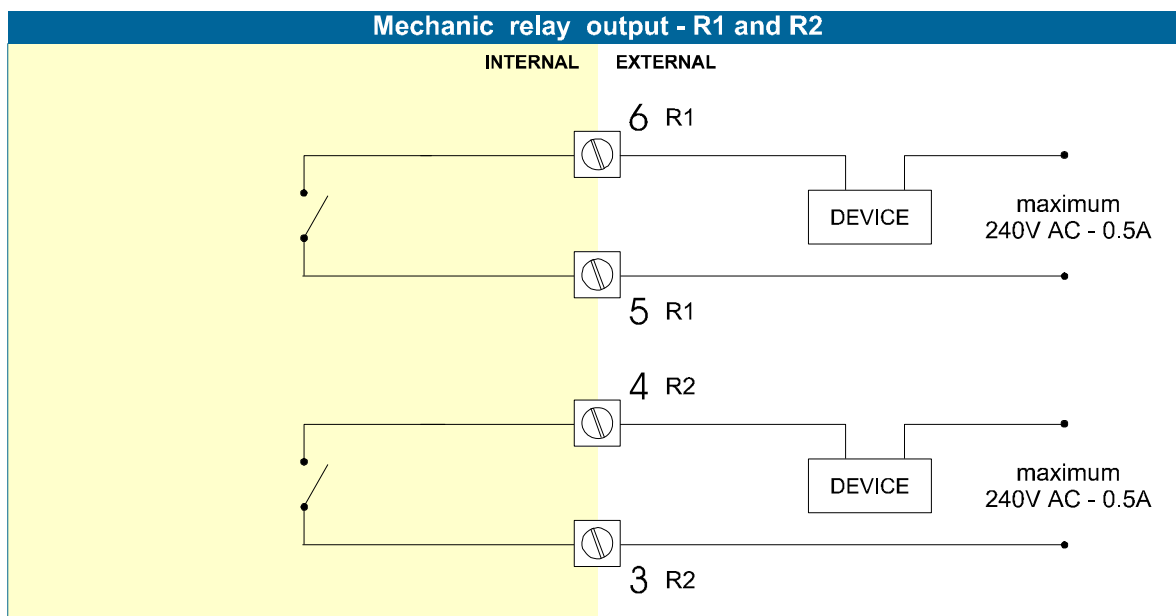

Type OT:

A passive transistor output is available with this option. Max. driving capacity 300mA@50V DC

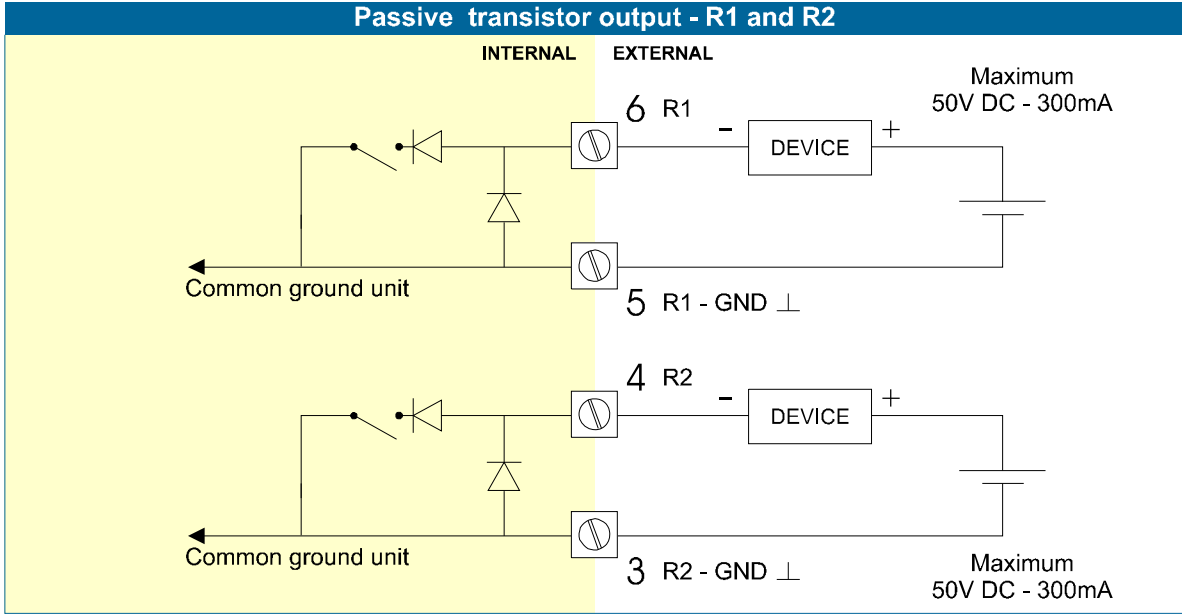

Terminal 07-08; basic POWER SUPPLY - type PX - output loop powered:

Connect an external power supply of 8-30VDC to these terminals or a 4-20mA loop. Do connect the "-" to terminal 7 and the "+" to terminal 8. When power is applied to these terminals, the (optional) internal battery will be disabled / enabled automatically to extend the battery life time.



Caution ! Only valid for standard passive output type AP!

Terminal 07-08 analog output (SETUP 7) :

An analog output signal proportional to the pressure is available as standard.

Type AA:

An active 4-20mA signal proportional to the pressure is available with this option. When the output is disabled, a 3.5mA signal will be generated on these terminals. Max. driving capacity 1000 Ohm @ 24VDC. (Requires power supply type PD / PF / PM).

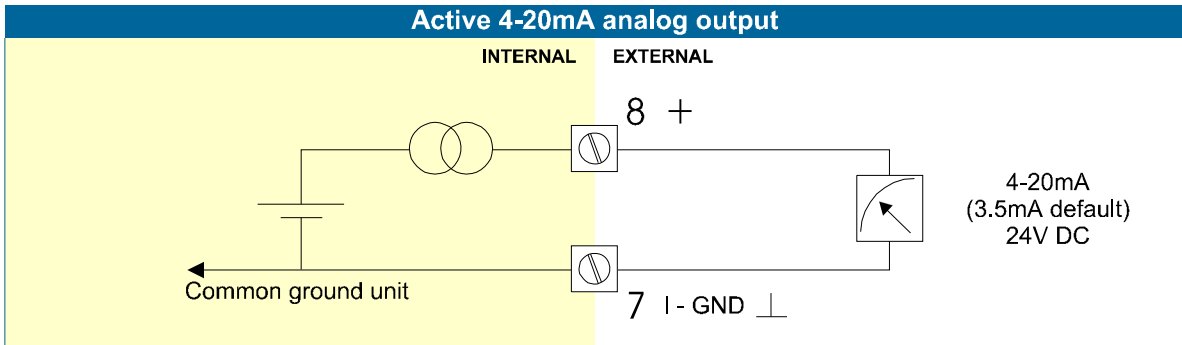

Type AB:

An active 0-20mA signal proportional to the pressure is available with this option.

Max. driving capacity 1000 Ohm @ 24VDC. (Requires power supply type PD / PF / PM).

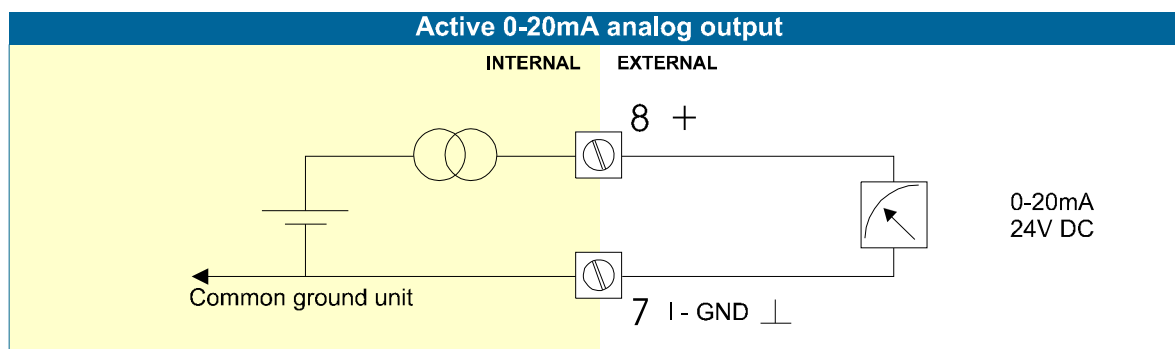
**Type AF:**

For the Intrinsically Safe floating 4-20mA signal: please read Chapter 5.

Type AI:

An isolated 4-20mA signal proportional to the pressure is available with this option.

When the output is disabled, a 3.5mA signal will be generated on these terminals.

Max. driving capacity 1000 Ohm @ 30VDC.

This option can be used with a battery powered unit but the life time of the battery is about 2 -3 years.

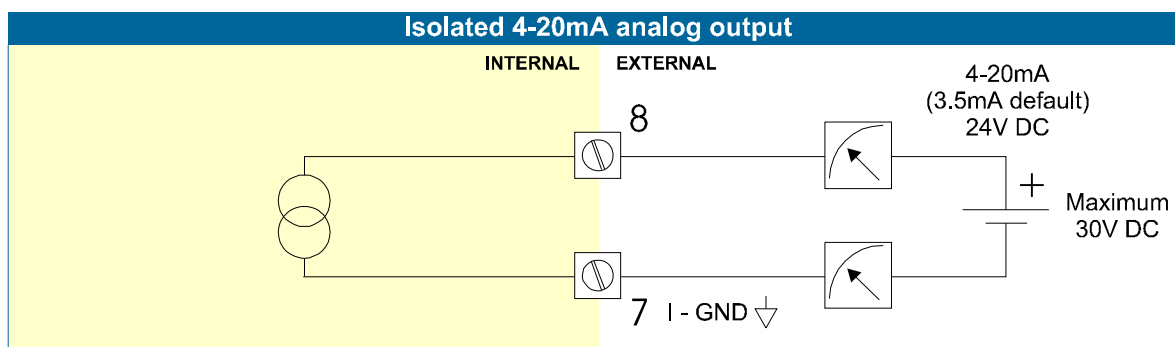
**Type AP:**

A passive 4-20mA signal proportional to the pressure is available with this option. When a power supply is connected but the output is disabled, a 3.5mA signal will be generated.

Max. driving capacity 1000 Ohm. This output does loop power the unit as well (type PX).

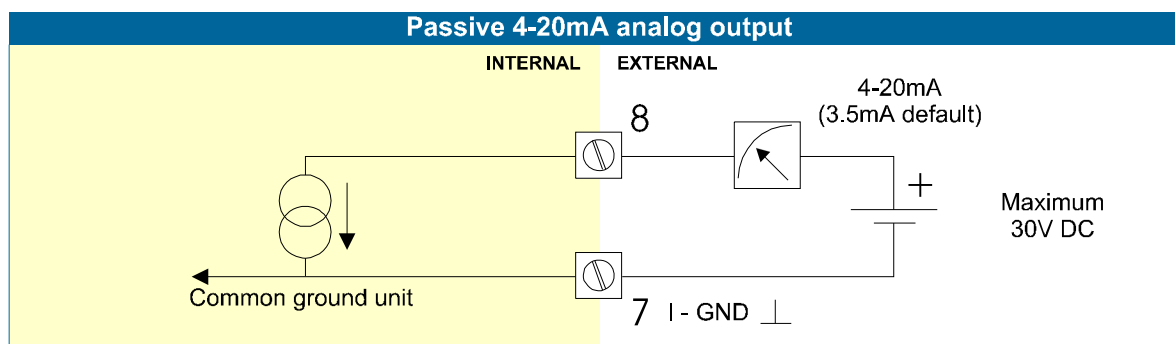

Type AU:

A 0-10VDC signal proportional to the pressure is available with this option.
 Max. load 10mA @ 10VDC. (Requires power supply type PD / PF / PM).

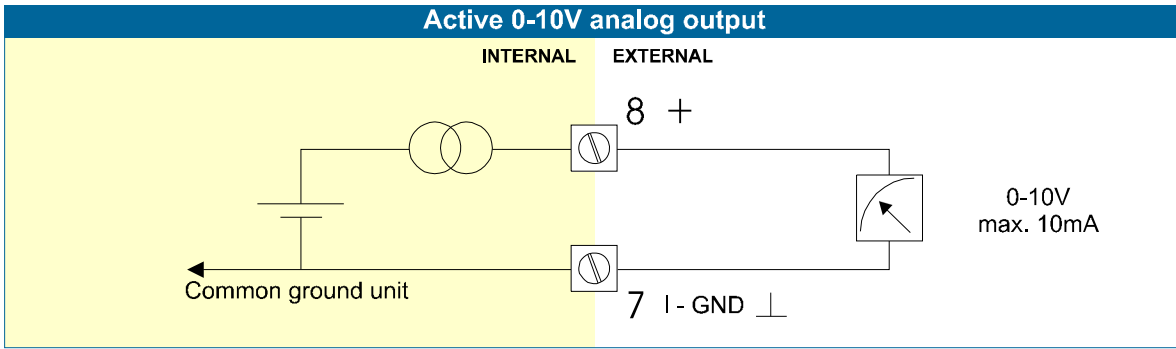

Terminal 09-11: Type A – Sensor input (general)

The F153-A requires a (0)4-20mA sensor signal which will be processed 4 times a second with a 14 bits accuracy. The input is not isolated.

For Intrinsically safe applications (without input loop power): please read chapter 5.

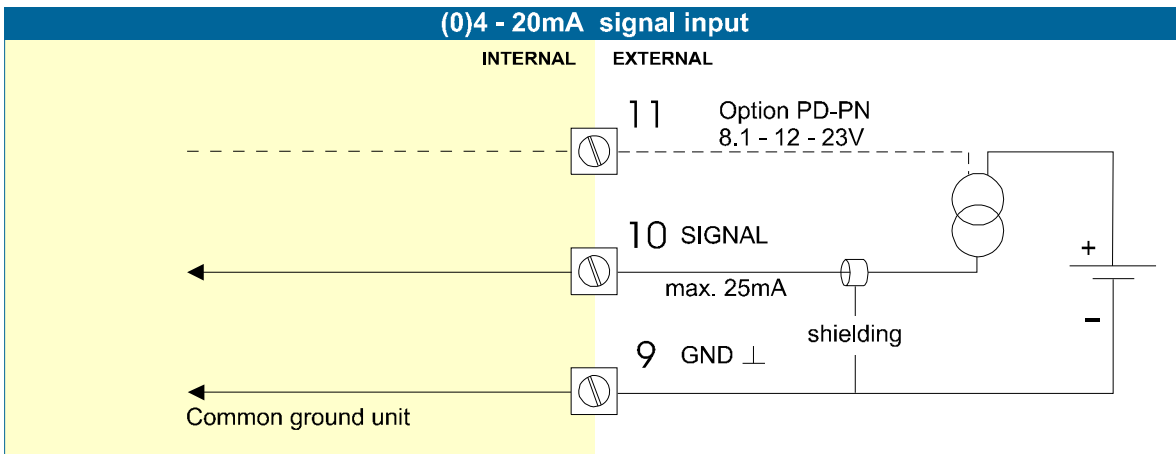

Terminal 09-10: Type A-PL – Sensor input / power supply:

The F153-A-PL requires a 4-20mA sensor signal which has a double function: The signal will be processed 4 times a second with a 14 bits accuracy and the unit will be powered from the sensor signal (input loop powered). The input is not isolated and not intrinsically safe.

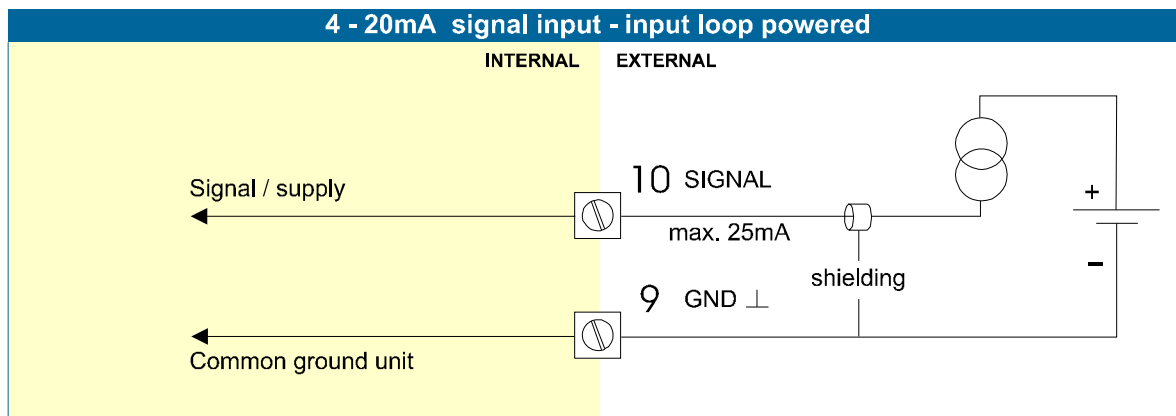

Terminal 15-16; alarm output R3:

This output is an alarm output according setup 83.

Type OT:

A passive transistor output is available with this option. Max. driving capacity 300mA@50V DC

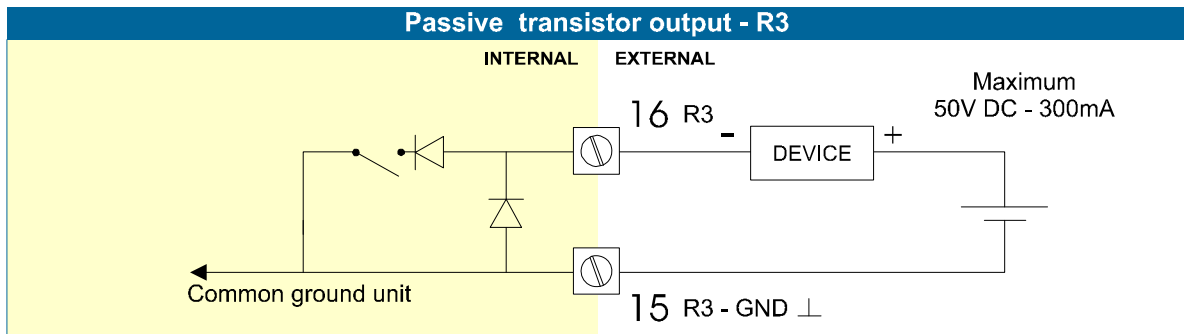

Type OA:

An active 24V DC pressure alarm output is available with this option.

Max. driving capacity 50mA@. (Requires power supply Type PD / PF / PM).

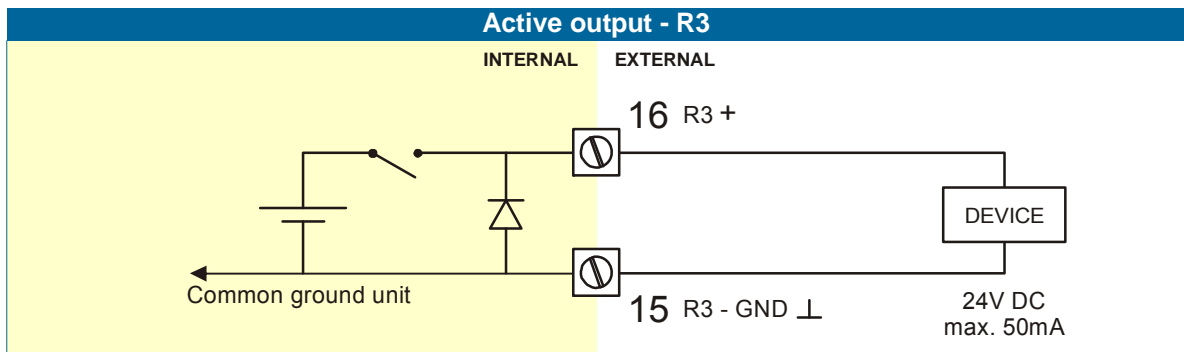

Terminal 26-31: type CB / CH / CI / CT - communication RS232 / RS485 / TTL (option)

- Full serial communications and computer control in accordance with RS232 (length of cable max. 15 meters) or RS485 (length of cable max. 1200 meters) is possible.
- Read the Modbus communication protocol and Appendix C.
- \

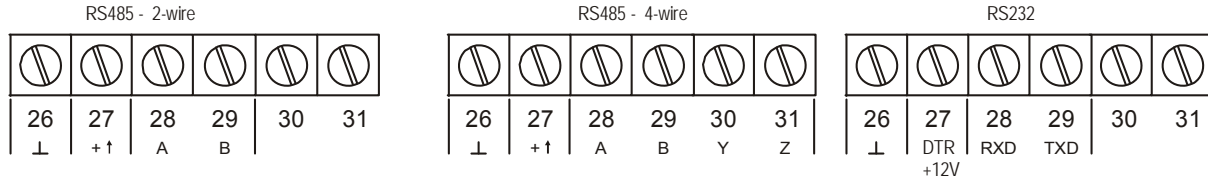

Fig. 11: Overview terminal connectors communication option.

When using the RS232 communication option, terminal 27 is used for supplying the interface. Please connect the DTR (or the RTS) signal of the interface to this terminal and set it active (+12V). If no active signal is available it is possible to connect a separate supply between terminals 26 and 27 with a voltage between 8V and 24V.

Terminal 26-31: backlight - type ZB (option):



Note: if the unit is supplied with a power supply type PD, PF or PM, the backlight supply is integrated, so the text following is not applicable.

To power the backlight, provide a 12-24V DC to terminal 26 (-) and 27 (+). An external trimmer 1kOhm trimmer can be used to tune the brightness of the backlight, or if not desired, a short-cut between these terminals have to be made which will result in the maximum brightness.



Note: Intrinsically Safe as well as 4-wire RS485 communication is not possible in combination with type ZB.

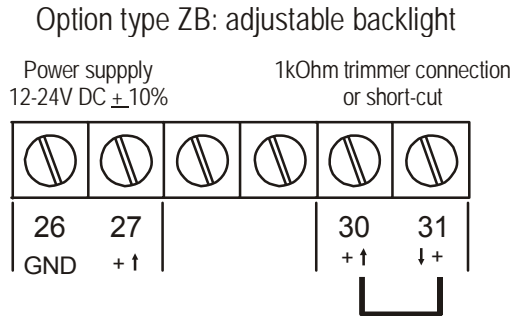

Fig. 12: Overview terminal connectors backlight option.

5. INTRINSICALLY SAFE APPLICATIONS

5.1. GENERAL INFORMATION AND INSTRUCTIONS



Cautions

- Mounting, electrical installation, start-up and maintenance of this device may only be carried out by trained personnel authorized by the operator of the facility. Personnel must read and understand this Operating Manual before carrying out its instructions.
- This device may only be operated by personnel who are authorized and trained by the operator of the facility. All instructions in this manual are to be observed.
- Ensure that the measuring system is correctly wired up according to the wiring diagrams. Protection against accidental contact is no longer assured when the housing cover is removed or the cabinet has been opened (danger of electric shock). The housing may only be opened by trained personnel.
- To maintain the degree of protection of at least IP65 in accordance with IEC 60529, certified cable entries in accordance with IEC 61241-0 must be used and correctly installed. Unused openings must be closed with suitable blanking elements.
- When the enclosure of the Indicator is made of aluminum alloy, when used in a potentially explosive atmosphere requiring apparatus of equipment protection level Ga and Da, the unit must be installed such that, even in the event of rare incidents, an ignition source due to impact or friction sparks between the enclosure and iron/steel is excluded.
- Take careful notice of the " Safety rules, instructions and precautionary measures " in the front of this manual.



Safety Instructions

- When two or more active intrinsically safe circuits are connected to the indicator, in order to prevent voltage and/or current addition, applicable to the external circuits, precautions must be taken to separate the intrinsically safe circuits in accordance with IEC 60079-11.
- For the combined connection of the different supply, input and output circuits, the instructions in this manual must be observed.
- From the safety point of view the circuits shall be considered to be connected to earth.
- For installation under ATEX directive: this intrinsically safe device must be installed in accordance with the ATEX directive 94/9/EC and the product certificate KEMA 03ATEX1074 X.
- For installation under IECEx scheme: this intrinsically safe device must be installed in accordance with the product certificate IECEx DEK 11.0042X.
- Exchange of Intrinsically Safe battery FWLiBAT-0xx with certificate number KEMA 03ATEX1071 U or IECEx KEM 08.0005U is allowed in Hazardous Area. See paragraph 5.4. for detailed battery replacement instructions.



Please Note

- Certificates, safety values and declaration of compliance can be found in the document named: "Fluidwell F1...-XI - Documentation for Intrinsic Safety".
- Special conditions for safe use mentioned in both the certificate and the installation instructions must be observed for the connection of power to both input and / or output circuits.
- When installing this device in hazardous areas, the wiring and installation must comply with the appropriate installation standards for your industry.
- Study the following pages with wiring diagrams per classification.

Label information (inside and outside the enclosure)

Indicated labels on the back cover (below) and on the inside cover (right) show the type labels for intrinsically safe certified units.

For details on usage see the separate “Fluidwell F1...-XI Documentation for Intrinsic Safety”.

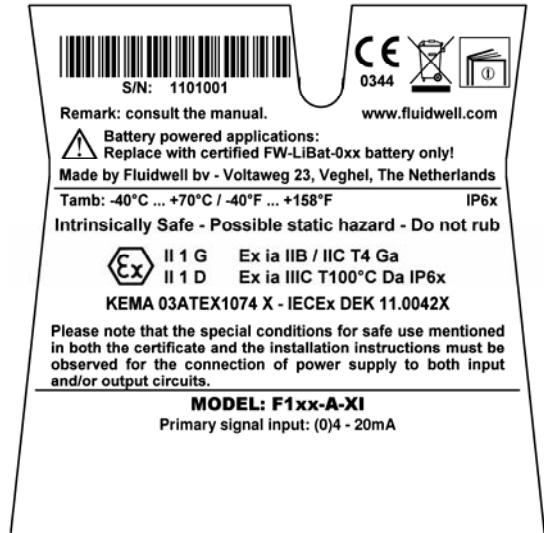
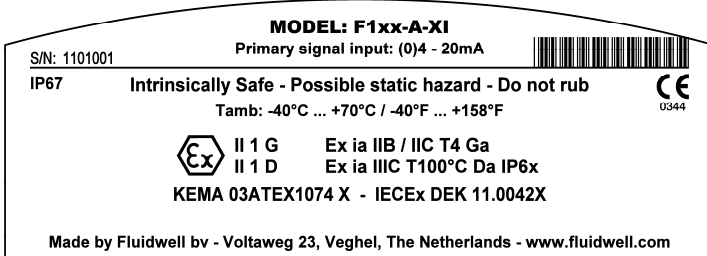

Serial number and year of production

This information can be looked-up on the display: See setup function (par. 3.2.2.) for details.

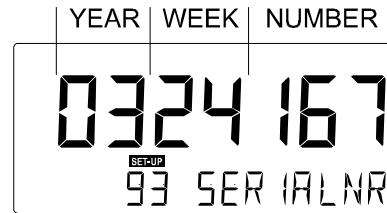

5.2. TERMINAL CONNECTORS INTRINSICALLY SAFE APPLICATIONS

The unit is classified as group IIB/IIIC by default.



Note !

Classification of the unit as group IIC is only possible under the following conditions:

- The indicator is either supplied by
 - the internal supply (option -PC); or
 - the external supply connected to terminals 0 and 1 (option -PD); or
 - the circuit supply connected to terminals 7 and 8 (option -AP);
 The maximum values for any of those circuits are those as defined for group IIB/IIIC;
- No other active external intrinsically safe circuits may be connected to the indicator, with exception of circuits connected to terminals 3 and 4 and/or terminals 5 and 6; the maximum values for any of those circuits are those as defined for group IIB/IIIC

Terminal connectors F153-A-XI:

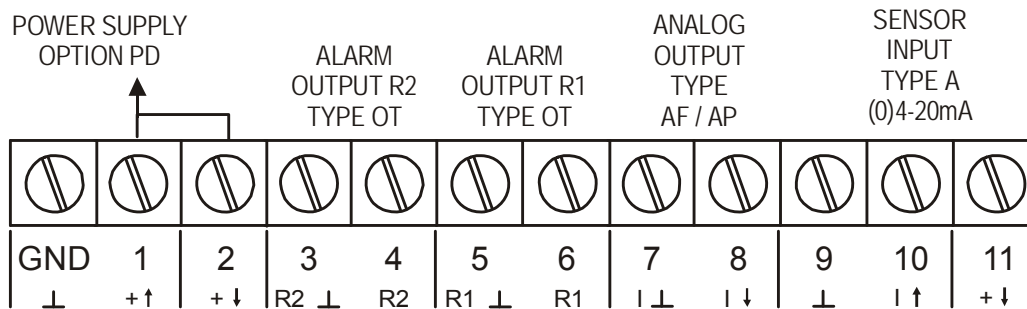

Fig. 13: Overview of Intrinsically Safe terminal connectors F153-A and options.

Explanation Intrinsically Safe options:

Type AF - Intrinsically Safe floating 4-20mA analog output - Terminal 7-8:

A floating 4-20mA signal proportional to the pressure is available with this option.

When the output is disabled, a 3.5mA signal will be generated.

Max. driving capacity 1000 Ohm @ 30V DC.



Note! It is required to link the minus from the analog output - terminal 7 - with a ground terminal of the unit; terminal: GND, 3, 5, 9, 12 or 15.

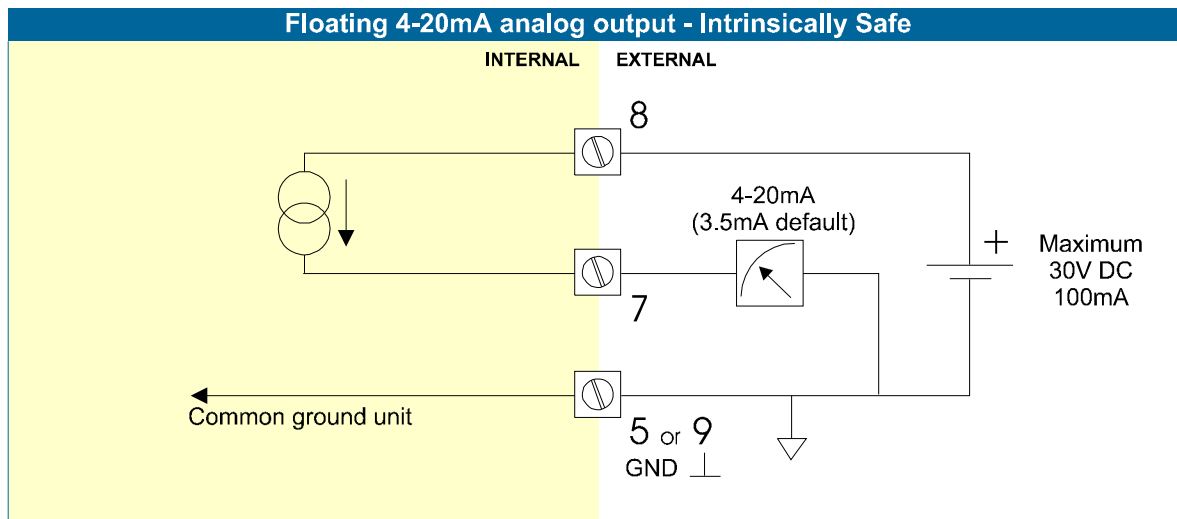

Type PD - Intrinsically Safe power supply and sensor supply - Terminal GND- 01 and 11.

OPTION	SENSOR SUPPLY (TERMINAL 11 AND 14)	Terminal		
		GND	01	02
PD-XI Input voltage: 8-30V DC	= input voltage	L-	L+	output voltage is according the input voltage; internally linked with terminal 01.

Terminal 02 and 11: these terminals offer the same voltage as connected to terminal 01.

5.3. CONFIGURATION EXAMPLES INTRINSICALLY SAFE APPLICATIONS

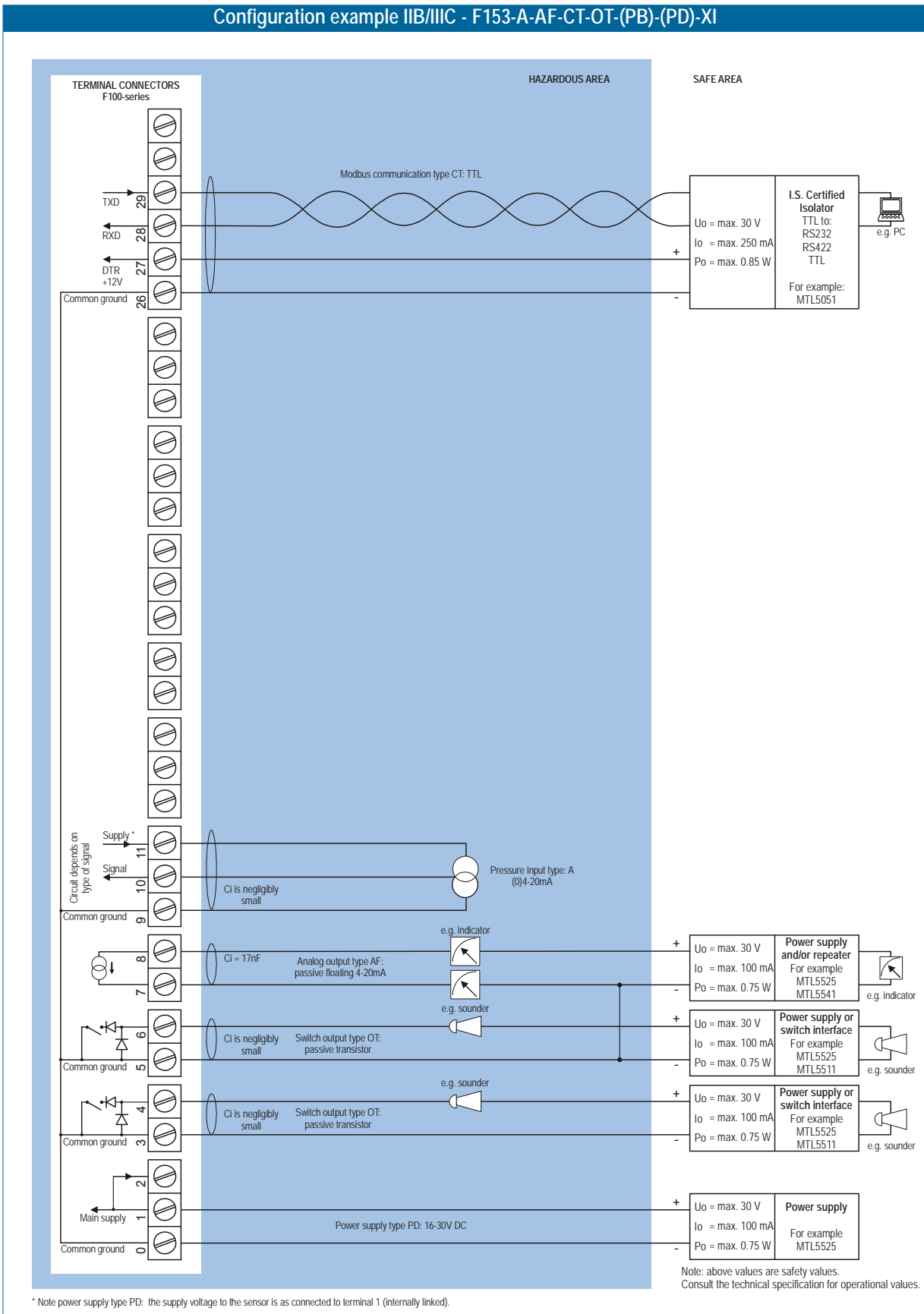

Fig. 14: Configuration example 1 Intrinsically Safe.

Configuration example IIB/IIIC - F153-A-AP-CT-OT-(PD)-XI

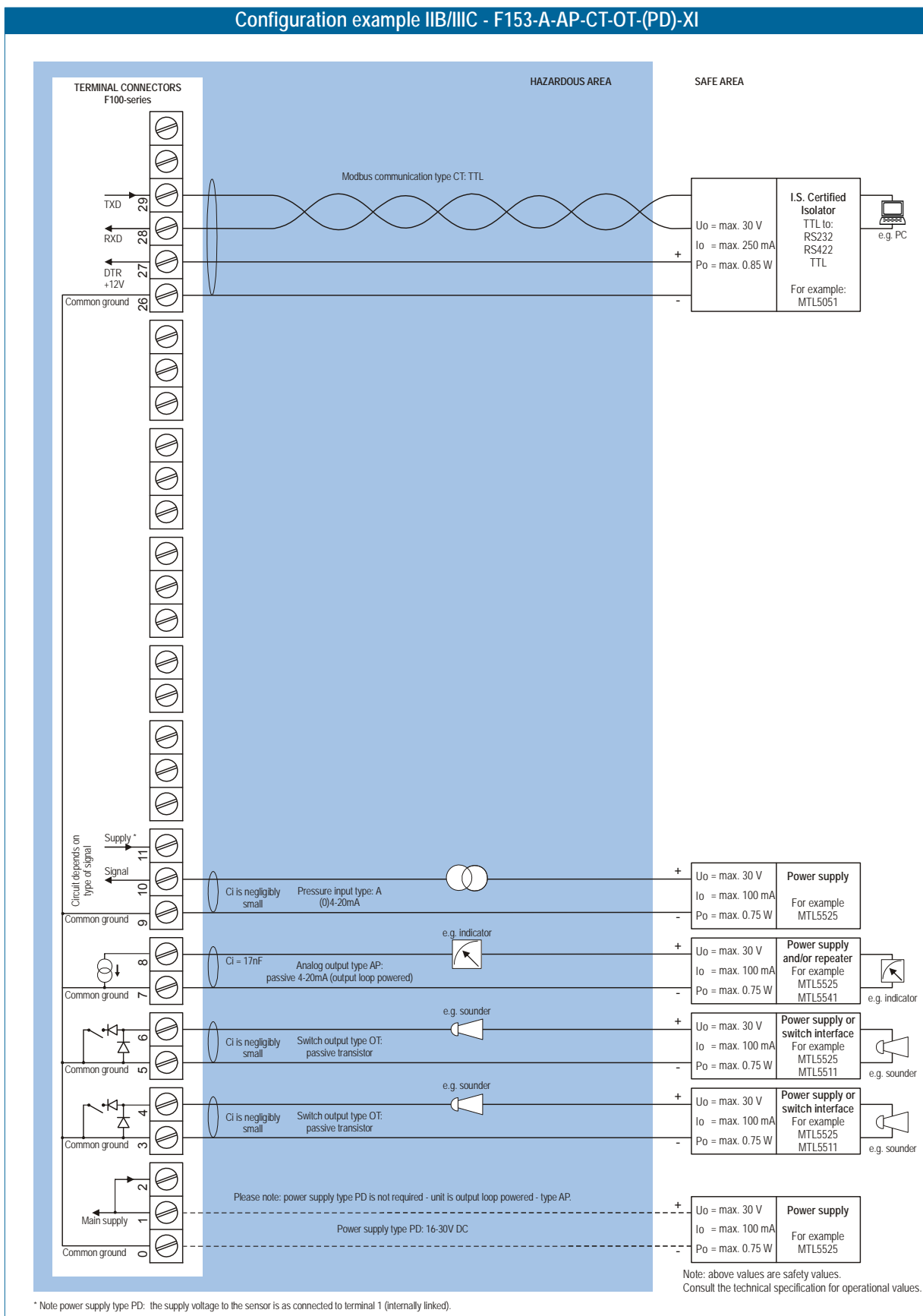

Fig. 15: Configuration example 2 Intrinsically Safe.

5.4 BATTERY REPLACEMENT INSTRUCTIONS

**Safety Instructions**

- **Fire, explosion or severe burns may result if mistreated.** Do not recharge, crush, disassemble, incinerate, heat above 100°C (212°F) or expose contents to water.
- Mounting, electrical installation, start-up and maintenance of this device may only be carried out by trained personnel authorized by the plant operator. Personnel must read and understand this instruction before carrying out the replacement procedure.
- Always follow the instructions listed in the supplied Battery Replacement Instruction Sheet.
- Batteries pose an environmental hazard. Return used batteries to a recycling point.

**Safety instructions for hazardous areas**

- Verify the correct battery is supplied: **Only batteries with indicated Ex label are certified for replacement and use in hazardous areas.** Batteries for use in safe areas have no Ex label. **DO NOT EXCHANGE:** Using the wrong type of battery can pose a SERIOUS RISK.
- **For use in hazardous areas Fluidwell recommends FW-LiBAT type batteries (manufactured by Fluidwell bv) only.**

Battery replacement procedure

Depending on the production batch, one of two visualized Intrinsically Safe certified battery types may have been installed in the unit. They are interchangeable.

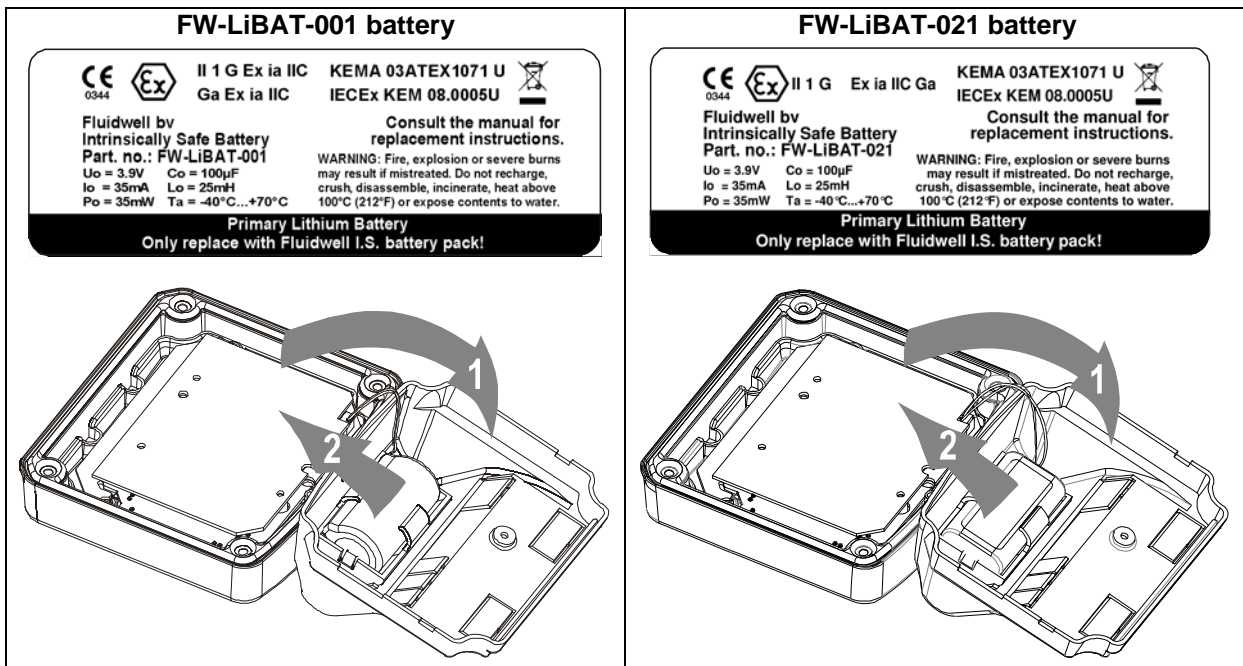

1. To replace the battery, open the unit to gain access to the back inside cover of the unit
2. Unplug the field connectors from the back inside of the unit.
3. Remove the screw that holds the plastic inside cover.
4. Open the cover and unplug the battery connector.
5. Remove the battery from the inside of the plastic cover. *Do not remove the battery clip!*
6. Install the new battery and re-assemble the unit in reverse order.
7. Start-up the unit.

6. MAINTENANCE

6.1. GENERAL DIRECTIONS



Caution !

- *Mounting, electrical installation, start-up and maintenance of the instrument may only be carried out by trained personnel authorized by the operator of the facility. Personnel must read and understand this Operating Manual before carrying out its instructions.*
- *The F153-A may only be operated by personnel who are authorized and trained by the operator of the facility. All instructions in this manual are to be observed.*
- *Ensure that the measuring system is correctly wired up according to the wiring diagrams. Protection against accidental contact is no longer assured when the housing cover is removed or the panel cabinet has been opened (danger from electrical shock). The housing may only be opened by trained personnel.*
- *Take careful notice of the " Safety rules, instructions and precautionary measures " in the front of this manual.*

The F153-A does not require special maintenance unless it is used in low-temperature applications or surroundings with high humidity (above 90% annual mean). It is the users responsibility to take all precautions to dehumidify the internal atmosphere of the F153-A in such a way that no condensation will occur, for example by placing dry silica-gel sachet in the casing just before closing it. Furthermore, it is required to replace or dry the silica gel periodically as advised by the silica gel supplier.

Battery life-time:

It is influenced by several issues as:

- Analog output signal; be sure that an external power supply is connected or that the function is disabled if not in use; else it has major influence on the battery life-time (SETUP 61).
- Display update: fast display update has major influence; SETUP 41.
- Alarm output and communication.
- Low temperatures; the available power will be less due to battery chemistry.



Note !

Note: *It is strongly advised to disable unused functions.*

Check periodically:

- The condition of the casing, cable glands and front panel.
- The input/output wiring for reliability and aging symptoms.
- The process accuracy. As a result of wear and tear, re-calibration of the sensor might be necessary. Do re-enter any subsequent Span alterations.
- The indication for low-battery.
- Clean the casing with soapy-water; don't use any aggressive solvents as these might damage the coating.

APPENDIX A: TECHNICAL SPECIFICATION

GENERAL

Display	
Type	High intensity reflective numeric and alphanumeric LCD, UV-resistant.
Digits	Seven 17mm (0.67") and eleven 8mm (0.31"). Various symbols and measuring units.
Refresh rate	User definable: 8 times/sec - 30 secs.
Type ZB	Transflective LCD with green LED backlight. Good readings in full sunlight and darkness. Note: only available for safe area applications. Power requirements: 12-24V DC + 10% or type PD, PF, PM. Power consumption max. 1 Watt.

Enclosures	
General	Die-cast aluminum or GRP (Glassfibre Reinforced Polyamide) enclosure with Polycarbonate window, silicone and EPDM gaskets. UV stabilized and flame retardant material.
Control Keys	Three industrial micro-switch keys. UV-stabilized silicone keypad.
Painting	Aluminum enclosure only: UV-resistant 2-component industrial painting.
Panel-mount enclosures	Dimensions: 130 x 120 x 60mm (5.10" x 4.72" x 2.38") – LxHxD.
Classification	IP65 / NEMA4X
Panel cut-out	115 x 98mm (4.53" x 3.86") LxH.
Type HC	GRP panel-mount enclosure
Type HB	Aluminum panel-mount enclosure
Field/wall-mount enclosures	Dimensions: 130 x 120 x 75mm (5.10" x 4.72" x 2.95") – LxHxD.
Classification	IP67 / NEMA4X
Aluminum enclosures	
Type HA	Drilling: 2x PG9 – 1x M20.
Type HM	Drilling: 2x M16 – 1x M20.
Type HN	Drilling: 1x M20.
Type HO	Drilling: 2x M20.
Type HP	Drilling: 6x M12.
Type HT	Drilling: 1x ½"NPT.
Type HU	Drilling: 3x ½"NPT.
Type HZ	No drilling.
GRP enclosures	
Type HD	No drilling.
Type HE	Drilling: 2x 16mm (0.63") – 1x 20mm (0.78").
Type HF	Drilling: 1x 22mm (0.87").
Type HG	Drilling: 2x 20mm (0.78").
Type HH	Drilling: 6x 12mm (0.47").
Option ZS	Silicone free ABS enclosure with EPDM and PE gaskets. UV-resistant polyester keypad. Note: this option comes with type HD only.

Operating temperature	
Operational	-40°C to +80°C (-40°F to +176°F)
Intrinsically Safe	-40°C to +70°C (-40°F to +158°F)

Power supply	
Type PB	Lithium battery - life-time depends upon settings - up to 5 years.
Type PC	Intrinsically Safe lithium battery - life-time depends upon settings - up to 5 years.
Type PD	8-24V AC / DC ± 10%. Power consumption max. 10 Watt. Intrinsically safe: 16-30V DC; power consumption max. 0.75 Watt.
Type PF	24V AC / DC ± 10%. Power consumption max. 15 Watt.
Type PL	Input loop powered from sensor signal 4-20mA (type A, non IS).
Type PM	115-230V AC ± 10%. Power consumption max. 15 Watt.
Type PX	Output loop powered: 8-30V DC. Power consumption max. 0.5 Watt.
Note PF / PM	The total consumption of the sensors', backlight and outputs may not exceed 400mA@24V.
Note I.S. applications	For intrinsically safe applications, consult the safety values in the certificate.

Sensor excitation	
Type PB / PC / PX	3.2V DC for pulse signals and 1.2V DC for coil pick-up. Note: This is not a real sensor supply. Only suitable for pulse sensors with a very low power consumption like coils (sine wave) and reed-switches.
Type PD	1.2 - 3.2 - 8.2 - 12 and 24V DC - max. 50mA@24V DC
Type PD-XI	Intrinsically safe: Pulse signals: 1.2 - 3.2 - 8.2 - max. 7mA@8.2V DC. Analog signals: the sensor supply voltage is according to the power supply voltage connected to terminal 1. Also terminal 2 offers the same voltage.
Type PF / PM	1.2 - 3.2 - 8.2 - 12 and 24V DC - max. 400mA@24V DC.

Terminal connections	
Type:	Removable plug-in terminal strip. Wire max. 1.5mm ² and 2.5mm ² (Type PM / PF)

Data protection	
Type	EEPROM backup of all setting. Backup of running totals every minute. Data retention at least 10 years.
Pass code	Configuration settings can be pass code protected.

Hazardous area (option)	
Intrinsically safe Type XI	ATEX approval:  II 1 G Ex ia IIB/IIC T4 Ga II 1 D Ex ia IIIC T100°C Da IP6x IECEx approval: Ex ia IIB/IIC T4 Ga Ex ia IIIC T100°C Da IP6x
Explosion proof Type XD/XF	ATEX approval ref.: <EX> II 2 GD EEx d IIB T5. Weight appr. 15kg. Dimensions of enclosure: 350 x 250 x 200mm (13.7" x 9.9" x 7.9") LxHxD.

Environment	
Electromagnetic compatibility	Compliant ref: EN 61326 (1997), EN 61010-1 (1993).

INPUTS

Sensor	
Type A	(0)4-20mA - with signal calibration feature at any current within the range.
Type U	0-10 V - with signal calibration feature at any voltage within the range.
Accuracy	Resolution: 14 bit.. Error < 0.025mA / ±0.125% FS. Low level cut-off programmable.
Span	0.000010 - 9,999,999 with variable decimal position.
Update time	Four times a second.
Voltage drop	2.5 Volt.
Load impedance	3kOhm
Note	For signal type A and U: external power to sensor is required; e.g. Type PD.

OUTPUTS

Analog output	
Function	transmitting actual pressure.
Accuracy	10 bit. Error < 0.05% - update 10 times a second. Software function to calibrate the 4.00mA and 20.00mA levels precisely within set-up.
Load	max. 1 kOhm
Type AA	Active 4-20mA output (requires type OA + PD, PF or PM).
Type AB	Active 0-20mA output (requires type OA + PD, PF or PM).
Type AF	Passive floating 4-20mA output for Intrinsically Safe applications (requires PC, PD or PL).
Type AI	Passive galvanically isolated output (requires PB, PD, PF, PL or PM).
Type AP	Passive 4-20mA output - output loop powered (type PX).
Type AU	Active 0-10V output (requires type OA + PD, PF or PM).

Alarm outputs	
Function	low, low-low, high, high-high or all alarms output.
Type OA	Three active 24V DC transistor outputs; max. 50mA per output (requires type AA + PD or PM).
Type OR	Two mechanic relay outputs; max. switch power 230V AC - 0,5A (requires type PF or PM) and one OT or OA output.
Type OS	Four mechanic relay outputs for alarms. Requires type AP + PD and OR. Not Intrinsically Safe.
Type OT	Three passive transistor outputs - not isolated. Load max. 50V DC - 300mA (XI: two outputs).

Communication option	
Functions	reading display information, reading / writing all settings.
Protocol	Modbus ASCII or RTU
Speed	1200 - 2400 - 4800 - 9600 baud
Addressing	maximum 255 addresses.
Type CB	RS232
Type CH	RS485 2-wire
Type CI	RS485 4-wire
Type CT	TTL Intrinsically Safe communication.
Type CX	no communication.

OPERATIONAL

Operator functions	
Displayed functions	<ul style="list-style-type: none"> • actual pressure • low-low alarm value • low alarm value • high alarm value • high-high alarm value

Pressure	
Digits	5 digits.
Units	BAR - mbar - PSI - no unit
Decimals	0 - 1 - 2 or 3.

APPENDIX B: PROBLEM SOLVING

In this appendix, several problems are included that can occur when the F153-A is going to be installed or while it is in operation.

Analog output does not function properly:

Check:

- SETUP 61 - is the function enabled?
- SETUP 62 / 63: are the pressure-levels programmed correctly?
- connection of the external power-supply according specification.

Alarm output does not function:

Check:

- SETUP 71 - 74 - did you enable the relays?
- SETUP 2 - alarm: are the correct alarm values programmed

The password is unknown:

If the password is not 1234, there is only one possibility left: call your supplier.

ALARM

When the alarm flag starts to blink an internal alarm condition has occurred. Press the "select button" several times to display the 5-digit error code. The codes are:

0001: irrecoverable display-data error: data on the display might be corrupted.

0002: irrecoverable data-storage error: the programming cycle might have gone wrong: check programmed values.

0003: error 1 and error 2 occurred simultaneously

The alarm condition will almost certainly be handled internally and if all mentioned values still appear correct, no intervention by the operator is needed. If the alarm occurs more often or stays active for a longer time, please contact your supplier.

APPENDIX C: COMMUNICATION VARIABLES

Remarks:

- Below, an overview of the F153-A specific variables; other common variables are described in the standard table.
- All numbers are decimal numbers, unless otherwise noted.
- Following variables of the standard table (var00-var30) are not valid for this product and will be responded with value 1: var00, 03-05, 07,08, 16-22, 24, 26-29.

CONFIGURATION VARIABLES F153-A - SETUP-LEVEL:				
VAR	DESCRIPTION	BYTES	VALUE	REMARKS
PRESSURE				
48 (30h)	unit	1	0=mbar 1=bar 2=psi 3=none	
50 (32h)	decimals	1	0...1	
51 (33h)	Span	3	1....99.999	
54 (36h)	decimals Span	1	0...5	
48 (30h)	unit	1		
50 (32h)	decimals	1	0...1	
51 (33h)	span	3	1....9.999.999	S 0000001 up to S 0000009 is allowed when decs < 6! (VAR54)
54 (36h)	decimals span	1	0...6	
ALARMS				
234 EAh	pressure low	3	0-9,9999	decimals: see 50 (32h)
237 EDh	pressure high	3	0-9,9999	decimals: see 50 (32h)
205 CDh	delay time alarm low pressure	2	1...9,999	steps of 0.1 second
DDh	delay time alarm high pressure	2	1...9,999	steps of 0.1 second
44h	edit pressure alarm	1	0=operator 1=SETUP-level	
46h	alarm at pressure zero	1	0=ignore 1=default 2=no relay	
DISPLAY				
68 (44h)	set pressure monitor	1	0=operator level 1=SETUP-level	
POWERMANAGEMENT				
80 (50h)	LCD update time	1	0=fast 1=1sec 2=3sec 3=15sec 4=30sec 5=off	
81 (51h)	power-mode battery	1	0=operational 1=shelf	
SENSOR				
99 (63h)	filter	1	0....99	

100 (64h)	cut-off	2	0...999	steps of 0.1%
102 (66h)	calibration low (4mA)	1	0=default 1=calibrate 2=cal set	
103 (67h)	calibration high (20mA)	1	0=default 1=calibrate 2=cal set	
ANALOG OUTPUT				
112 (70h)	analog output	1	0=disable 1=enable	
113 (71h)	minimum rate	3	0..9999999	unit, time, decimals acc. var48-50
116 (74h)	maximum rate	3	0..9999999	unit, time, decimals acc. var48-50
119 (77h)	cut off percentage	1	0..99	steps of 0.1%
120 (78h)	tune minimum rate	2	0..9999	
122 (7Ah)	tune maximum rate	2	0..9999	
99 (63h)	filter	1	0...99	
VAR	DESCRIPTION	BYTES	VALUE	REMARKS
OTHERS				
168 (A8h)	password	2	xxxx	read only!
170 AAh	tagnumber	3	0..9999999	Other vars: see standard table

OTHER F153-A VARIABLES FOR COMMUNICATION

PRESSURE - variable number 572 (23Ch) – 4 bytes

READ PRESSURE: The value difference as mentioned with total/acc. total might appear here too.

WRITE PRESSURE: Impossible.

INDEX OF THIS MANUAL

actual settings	47	Low-battery alarm	9
alarm output	27, 31	main-function	11
analog		maintenance	39
floating output.	35	model	20
flowrate min.	18	Operator level	8
intrinsically safe output.	35	password	20, 43
<i>output loop powered.</i>	28	power supply	26, 28
Analog output	28	power supply intrinsically safe	35
Backlight	32	pressure	8
battery life time	16, 39	alarm	9
communication	32	alarm value	8
family-specific variables	44	decimals	14
Configuration	10	decimals Span	14
Dimension enclosures	22, 23	Span	14
display update	16	Problem solving	43
Flowmeter input	30	serial number	20
Installation	21	SETUP-level	10
Intrinsic safety	33	subfunction	11
Intrinsically Safe options	35	tagnumber	20
IP classification	21	Technical specification	40
keys	7	terminal connectors	26
low-battery	9	version software	20

LIST OF FIGURES IN THIS MANUAL

Fig. 1: Typical application for the F153-A.	5
Fig. 2: Control Panel.	7
Fig. 3: Example of display information during process.	8
Fig. 4: Example display information during programming maximum pressure.	8
Fig. 5: Example of low-battery alarm.	9
Fig. 6: Dimensions aluminum enclosures.	22
Fig. 7: Dimensions GRP enclosures.	23
Fig. 8: Grounding aluminum enclosure with type PM 115-230V AC.	24
Fig. 9: Switch setting sensor supply voltage.	25
Fig. 10: Overview terminal connectors standard configuration F153-A and Types.	26
Fig. 11: Overview terminal connectors communication option.	32
Fig. 12: Overview terminal connectors backlight option.	32
Fig. 13: Overview of Intrinsically Safe terminal connectors F153-A and options.	34
Fig. 14: Configuration example 1 Intrinsically Safe.	36
Fig. 15: Configuration example 2 Intrinsically Safe.	37

NOTES

LIST OF CONFIGURATION SETTINGS			
SETTING	DEFAULT	DATE :	DATE :
1 - PRESSURE			
11 unit	BAR		
12 decimals	00000		
13 span	00001		
14 decimals span	0		
15 offset	0		
2 - ALARM			
21 offset	default		
22 alarm low-low	0		
23 alarm low	0		
24 alarm high	0		
25 alarm high-high	0		
26 delay alarm low-low	0.0 sec		
27 delay alarm low	0.0 sec		
28 delay alarm high	0.0 sec		
29 delay alarm high-high	0.0 sec		

SETTING	DEFAULT	DATE :	DATE :
3 - DISPLAY			
31 alarm set	operator		
4 - POWER MANAGEMENT			
41 LCD-new	1 sec.		
42 mode	operational		
5 - SENSOR			
51 filter	01 (off)		
52 cut-off %	00.0%		
53 calibrat. low-(0)4mA	default		
54 calibrat. high-20mA	default		
6 - ANALOG OUTPUT			
61 output	disabled		
62 min. pressure 4mA / 0V	0000000		
63 max. pressure 20mA / 10V	9999999		
64 cut off percentage	0.0%		
65 tune min - 4mA / 0V	0208		
66 tune max - 20mA / 10V	6656		
67 filter	01 (off)		
7 - RELAY OUTPUT			
71 output R1	off		
72 output R2	off		
73 output R3	off		
74 output R4	off		
8 - COMMUNICATION			
81 baud-rate	2400		
82 address	1		
83 mode	BUS-ASC		
9 - OTHERS			
91 model	F153-A	F153-A	F153-A
92 software version			
93 serial number			
94 pass code	0000		
95 tagnumber	0000000		

