

# ***F126-P-EL-TP***

## **FLOW COMPUTER**

**temperature compensation for corrected liquid volume**

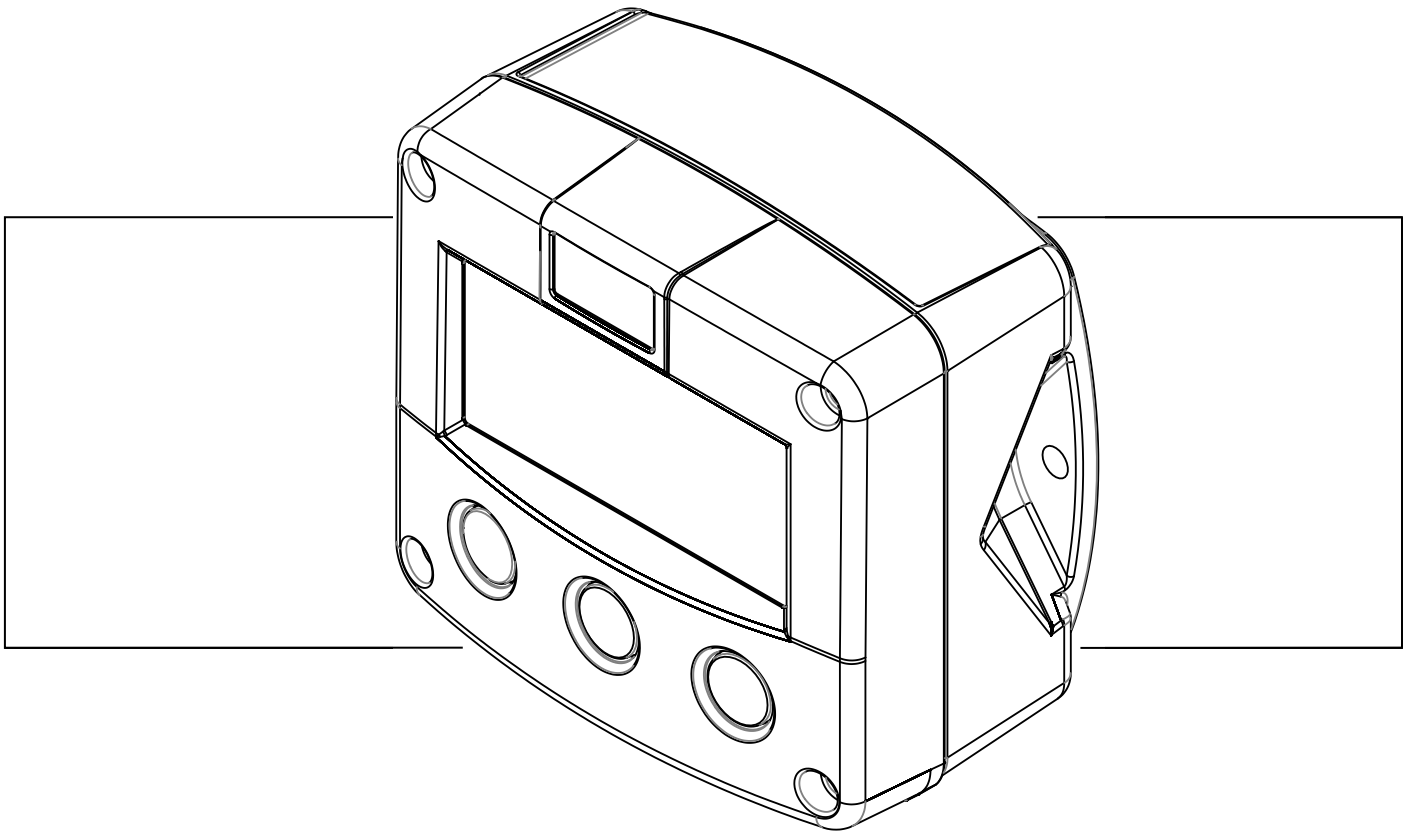

***Signal input flowmeter: pulse, Namur and coil***

***Signal outputs: (0)4-20mA ref. flow rate and pulse ref. total***

***Options: Intrinsically safe, Modbus communication, external reset and backlight***





## SAFETY INSTRUCTIONS

- Any responsibility is lapsed if the instructions and procedures as described in this manual are not followed.
- **LIFE SUPPORT APPLICATIONS:** The F126-P is not designed for use in life support appliances, devices, or systems where malfunction of the product can reasonably be expected to result in a personal injury. Customers using or selling these products for use in such applications do so at their own risk and agree to fully indemnify the manufacturer and supplier for any damages resulting from such improper use or sale.
- Electro static discharge does inflict irreparable damage to electronics! Before installing or opening the unit, the installer has to discharge himself by touching a well-grounded object.
- This unit must be installed in accordance with the EMC guidelines (Electro Magnetic Compatibility).
- Do connect a proper grounding to the metal enclosure as indicated if the F126-P has an incoming power line which carries a 115-230V AC. The Protective Earth (PE) wire may never be disconnected or removed.
- Inherently safe applications: follow the instructions as mentioned in Chapter 5 and consult “Fluidwell F1...-XI - Documentation for Intrinsic safety”.

## DISPOSAL OF ELECTRONIC WASTE



- The WEEE Directive requires the recycling of disposed electrical and electronic equipment in the European Union. When the WEEE Directive does not apply to your region, we support its policy and ask you to be aware on how to dispose of this product.
- The crossed out wheeled bin symbol as illustrated and found on our products tells that this product shall not be disposed of into the general waste system or into a landfill.
- At the end of its life, equipment shall be disposed of according to the local regulations regarding waste of the electrical and the electronic equipment.
- Please contact your local dealer, national distributor or the manufacturer's Technical helpdesk for information on the product disposal.

## SAFETY RULES AND PRECAUTIONARY MEASURES

- The manufacturer accepts no responsibility whatsoever if the following safety rules and precautions instructions and the procedures as described in this manual are not followed.
- Modifications of the F126-P-EL-TP implemented without preceding written consent from the manufacturer, will result in the immediate termination of product liability and warranty period.
- Mounting, electrical installation, start-up and maintenance of this device may only be carried out by trained persons authorized by the operator of the facility. Persons must read and understand this manual before carrying out its instructions.
- This device may only be operated by persons who are authorized and trained by the operator of the facility. All instructions in this manual are to be observed.
- Check the mains voltage and information on the manufacturer's plate before installing the unit.
- Check all connections, settings and technical specifications of the various peripheral devices with the F126-P supplied.
- Open the enclosure only if all leads are free of potential.
- Never touch the electronic components (ESD sensitivity).
- Never expose the system to heavier conditions than allowed according the classification of the enclosure (see manufacture's plate and chapter 4).
- If the operator detects errors or dangers, or disagrees with the safety precautions taken, then inform the owner or principal responsible.
- The local labor and safety laws and regulations must be adhered to.

## ABOUT THE MANUAL

This manual is divided into two main sections:

- The daily use of the unit is described in chapter 2 "Operation". These instructions are meant for users.
- The following chapters and appendices are exclusively meant for electricians/technicians. These provide a detailed description of all software settings and hardware installation guidance.

This manual describes the standard unit as well as the available options. For additional information, please contact your supplier.

**A hazardous situation may occur if the F126-P is not used for the purpose it was designed for or is used incorrectly. Please carefully note the information in this manual indicated by the pictograms:**



A "**warning !**" indicates actions or procedures which, if not performed correctly, may lead to personal injury, a safety hazard or damage of the F126-P or connected instruments.



Caution !

A "**caution !**" indicates actions or procedures which, if not performed correctly, may lead to personal injury or incorrect functioning of the F126-P or connected instruments.



Note !

A "**note !**" indicates actions or procedures which, if not performed correctly, may indirectly affect operation or may lead to an instrument response which is not planned.

Hardware version	: 03.01.xx
Software version	: 03.03.xx
Manual	: FW_F126PELTP_v1702_02_EN
© Copyright 2017	: Fluidwell B.V. - the Netherlands

**Information in this manual is subject to change without prior notice. The manufacturer is not responsible for mistakes in this material or for incidental damage caused as a direct or indirect result of the delivery, performance or use of this material.**

**© All rights reserved. No parts of this publication may be reproduced or used in any form or by any means without written permission of your supplier.**

# CONTENTS MANUAL

<b>SAFETY INSTRUCTIONS</b> .....	<b>3</b>
<b>DISPOSAL OF ELECTRONIC WASTE</b> .....	<b>3</b>
<b>SAFETY RULES AND PRECAUTIONARY MEASURES</b> .....	<b>3</b>
<b>ABOUT THE MANUAL</b> .....	<b>4</b>
<b>CONTENTS MANUAL</b> .....	<b>5</b>
<b>1. INTRODUCTION</b> .....	<b>6</b>
1.1. System description .....	6
<b>2. OPERATIONAL</b> .....	<b>7</b>
2.1. Control panel .....	7
2.2. Operator information and functions .....	8
<b>3. CONFIGURATION</b> .....	<b>9</b>
3.1. How to program the F126-P .....	9
3.1.2. Setup menu - Settings .....	11
3.1.3. Explanation of setup menu 1 - Total .....	12
3.1.4. Explanation of setup menu 2 - Flow rate .....	12
3.1.5. Explanation of setup menu 3 - Display .....	13
3.1.6. Explanation of setup menu 4 - Power management .....	13
3.1.7. Explanation of setup menu 5 - Flowmeter .....	14
3.1.8. Explanation of setup menu 6 - Temperature .....	14
3.1.9. Explanation of setup menu 7 - Formula .....	15
3.1.10. Explanation of setup menu 8 - Analog .....	15
3.1.11. Explanation of setup menu 9 - Pulse .....	16
3.1.12. Explanation of setup menu A - Communication (option) .....	17
3.1.13. Explanation of setup menu B - Others .....	17
<b>4. INSTALLATION</b> .....	<b>18</b>
4.1. General directions .....	18
4.2. Installation - surrounding conditions .....	18
4.3. Dimensions- Enclosure .....	19
4.4. Installing the hardware .....	21
4.4.1. General installation guidelines .....	21
4.4.2. Aluminum enclosure - Field mounted .....	22
4.4.3. Aluminum enclosure - Panel mounted .....	22
4.4.4. Plastic (GRP) enclosure .....	23
4.4.5. Terminal connectors .....	24
4.4.6. Voltage selection sensor supply .....	24
<b>5. INTRINSICALLY SAFE APPLICATIONS</b> .....	<b>31</b>
5.1. General information and instructions .....	31
5.2. Terminal connectors Intrinsically safe applications .....	33
5.3. Configuration examples .....	35
5.4. Battery replacement instructions .....	37
5.4.1. Safety instructions .....	37
5.4.2. Replace the battery (hazardous area) .....	37
5.4.3. Disposal of batteries .....	37
<b>6. MAINTENANCE</b> .....	<b>38</b>
6.1. General directions .....	38
6.2. Repair .....	38
<b>APPENDIX A. TECHNICAL SPECIFICATIONS</b> .....	<b>39</b>
<b>APPENDIX B. PROBLEM SOLVING</b> .....	<b>42</b>
<b>APPENDIX C. COMMUNICATION VARIABLES</b> .....	<b>43</b>
<b>APPENDIX D. DECLARATION OF CONFORMITY</b> .....	<b>47</b>
<b>INDEX OF THIS MANUAL</b> .....	<b>48</b>
<b>LIST OF FIGURES IN THIS MANUAL</b> .....	<b>49</b>

# 1. INTRODUCTION

## 1.1. SYSTEM DESCRIPTION

### Functions and features

The flow computer, model F126-P-EL-TP is a microprocessor driven instrument for the calculation of the flow rate from a liquid medium with respect to temperature and pressure.

This product has been designed with a focus on:

- ultra-low power consumption to allow long-life battery powered applications (type PB/PC),
- intrinsic safety for use in hazardous applications (type XI),
- several mounting possibilities with aluminum or GRP enclosures for harsh industrial surroundings,
- ability to process all types of flowmeter signals,
- transmitting possibilities with analog, pulse and communication outputs.

### Flowmeter and temperature input

This manual describes the unit with a pulse input from the flowmeter. The F126-P has also a PT100 temperature input. Other versions are available to process (0)4-20mA signals.

One flowmeter with a passive or active pulse, Namur or sine wave (coil) signal output can be connected to the F126-P. To power the sensor, several options are available.

### Standard output

- Pulse output to transmit a pulse that represents a totalized quantity as programmed.
- Linear (0)4-20mA or 0-10V analog output to represent the actual flow rate as programmed. The (0)4-20mA or 0-10V signal limits can be tuned.

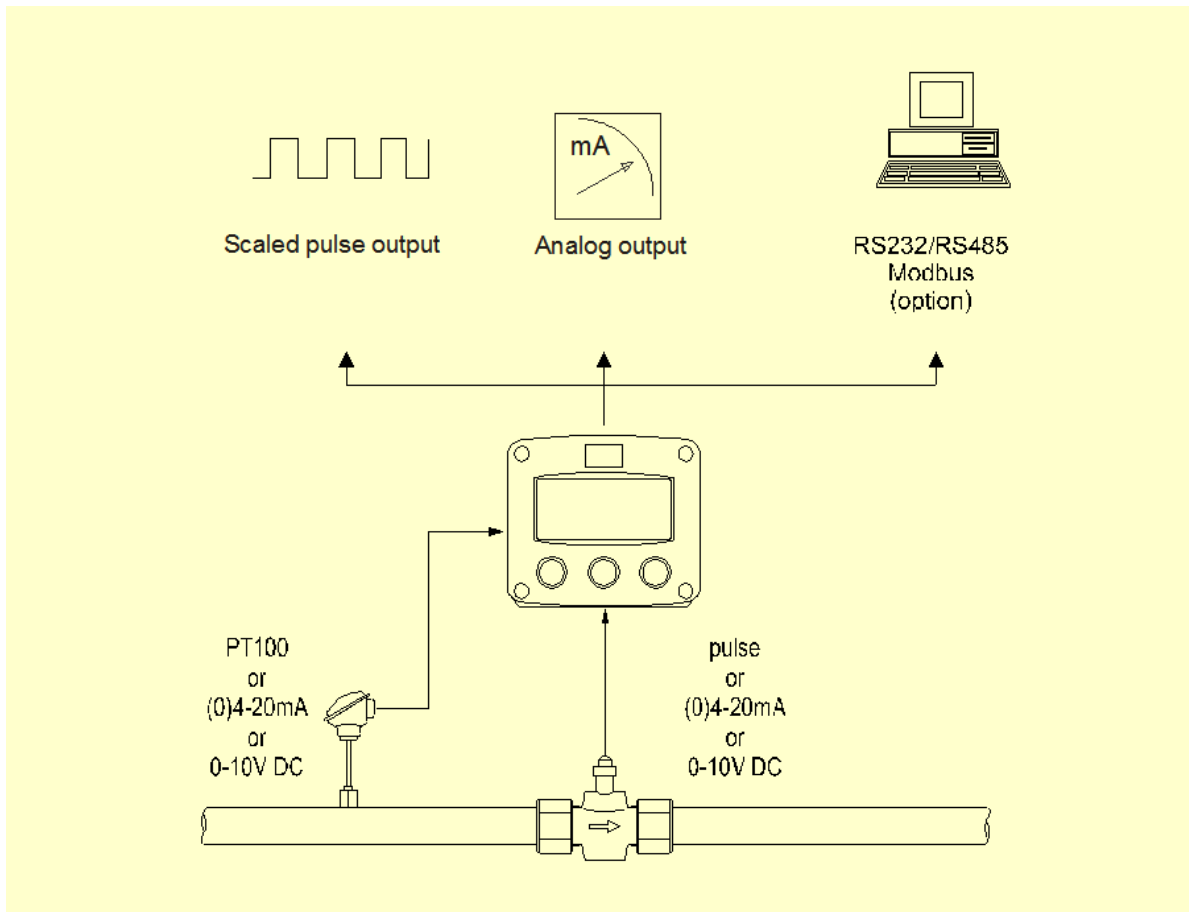

**Fig. 1: typical application**

### Configuration of the unit

The F126-P is designed for use in many types of applications. For that reason, a setup menu is available to program the F126-P according to your specific requirements.

The setup includes several important features, such as K-Factors, engineering units, signal selection, power management (to extend battery life-time), etc. All settings are stored in a non-volatile memory and therefore kept in the event of a power failure or an exhausted battery.

### Display information

The unit has a LCD with (optional) backlight to show the process information, status and alarm messages. The display refresh rate is programmed in the setup menu.

At a key press, the display refresh rate will switch to FAST for 30 seconds. When 'OFF' is selected, the display goes off after 30 seconds after the last key press. The display temporarily comes on after a key press.

A backup of the total and accumulated total in EEPROM memory is made every minute.

### Options

The following options are available: isolated or active (0)4-20mA / 0-10V analog output, full Modbus communication RS232/485/TTL (also battery powered), intrinsic safety, mechanical relay or active output, power- and sensor-supply options, extended measurement range for PT100, panel -mount, wall-mount and weather-proof enclosures, flame proof enclosure and LED backlight.

## 2. OPERATIONAL



- This device may only be operated by persons who are authorized and trained by the operator of the facility. All instructions in this manual are to be observed.
- Take careful notice of the "Safety rules, instructions and precautionary measures" in the front of this manual.

This chapter describes the daily use of the F126-P. This instruction is meant for users / operators.

### 2.1. CONTROL PANEL

The control panel has three keys. The available keys are:



Fig. 2: Control Panel

#### Functions of the keys



This key is used to program and save new values or settings. The PROG/ENTER key is also used to gain access to the setup menu (read chapter 3).



This key is used to select the accumulated total and the temperature. The SELECT/▲ key is also used to increase a value after the PROG/ENTER key has been pressed (read chapter 3).



This key is used to reset the total. The CLEAR/▶ key is also used to select a digit or an option after the PROG/ENTER key has been pressed (read chapter 3).

## 2.2. OPERATOR INFORMATION AND FUNCTIONS

In general, the F126-P operates in the operator mode. The shown information depends on the settings which are made in the setup menu. The signal from the connected sensor is processed by the F126-P in the background, independent from the selected display refresh rate.



Fig. 3: Process information (typical)

For the Operator, the following functions are available:

- **Display calculated flow rate and calculated total or calculated flow rate**  
This is the main display information of the F126-P. After the selection of any other information, it will always return to this main display automatically. Total is shown on the upper line of the display and flow rate on the bottom line. When selected in the setup menu, the display shows the flow rate only. When you press the select key, the total shows momentarily. When "-----" is shown, the flow rate value is too high to be shown. The arrows  $\blacktriangle$  indicate the increase/decrease of the flow rate trend.
- **Clear total**  
The value for total can be reset. To do so, press the CLEAR/  $\blacktriangleright$  key twice. When the key is pressed once, the text "PUSH CLEAR" is shown. To avoid a reset at this stage, press another key other than the CLEAR/  $\blacktriangleright$  key or wait for 20 seconds. A reset of the total does not influence the accumulated total.
- **Display calculated accumulated total**  
When the SELECT/  $\blacktriangle$  key is pressed, total and accumulated total are shown. The accumulated total cannot be reset. The value will count up to 99,999,999,999. The unit and number of decimals are shown according to the settings for the total.
- **Display line temperature**  
When the SELECT/  $\blacktriangle$  key is pressed twice, the actual temperature is shown.
- **Range error**  
As soon as the input value is out of the calibrated PT100 measurement range, the alarm indicator shows. When the SELECT/  $\blacktriangle$  key is pressed a few times, the alarm code is shown in the alarm display. This alarm is also activated at a wire break or faulty sensor. (standard range -100°C - +200°C or extended range, type ZV: -200° - +800°C).
- **Low-battery alarm**



*Only use original batteries. Original batteries can be ordered at the manufacturer.  
The use of unapproved batteries will void the warranty.*

Note !

At the end of the battery's life-time, the voltage starts to drop. When the voltage becomes too low, the battery indicator comes on. When the battery indicator is on, install a new and fresh battery as soon as possible.



Fig. 4: Low-battery alarm (typical)

- **Alarm**  
When the alarm indicator is shown, refer to Appendix B: Problem Solving.



### 3. CONFIGURATION

This and the following chapters are exclusively meant for electricians and non-operators. In these, an extensive description of all software settings and hardware connections are provided.



Caution !

- Mounting, electrical installation, start-up and maintenance of this device may only be carried out by trained persons authorized by the operator of the facility. Persons must read and understand this manual before carrying out its instructions.
- This device may only be operated by persons who are authorized and trained by the operator of the facility. All instructions in this manual are to be observed.
- Make sure, the measuring system is correctly wired up according to the wiring diagrams. Protection against accidental contact is no longer assured when the housing cover is removed or the panel cabinet has been opened (danger from electrical shock). The housing may only be opened by trained persons authorized by the operator of the facility.
- Take careful notice of the "Safety rules, instructions and precautionary measures" in the front of this manual.

The setup menu is used to program the F126-P.

The setup menu is accessible at all times while the F126-P remains fully operational. Be aware that in this case any change to the settings may have an influence on the operation.



Note !

*It is possible to prevent access to the setup menu with a password. A password may be required to enter the setup menu. Without this password, access is denied.*

#### 3.1. HOW TO PROGRAM THE F126-P

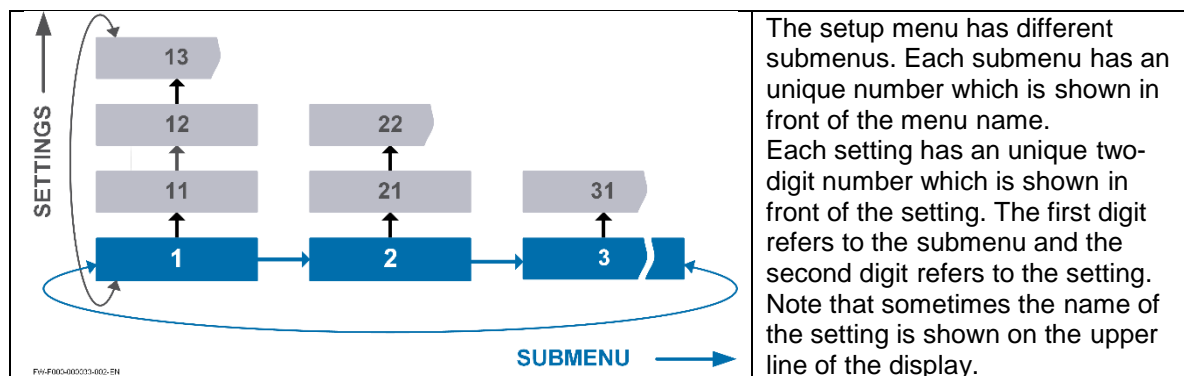

##### How to enter the setup menu

When the setup menu is protected by a password, the F126-P asks for a password to access the setup menu. When in the operator mode, press and hold the PROG/ENTER key for 7 seconds to access the setup menu.

##### How to navigate in the setup menu

The setup menu has different submenus to program the F126-P. For navigation, the submenus and the settings are identified with numbers (for the submenu: e.g. 1; for the setting: e.g. 12.). The CLEAR/▶ key and the PROG/ENTER key are used for navigation. The explanation assumes that you are in the submenu TOTAL.

Action	Result	Remark
1 Press the CLEAR/▶ key to select the next submenu.	• The submenu FLOW RATE shows	-
2 Press again to go to the next submenu.	• The submenu DISPLAY shows.	-
3 Momentarily, press the PROG/ENTER key to select the previous submenu.	• The submenu FLOW RATE shows	The PROG/ENTER key is used as a ◀ key.
4 Press again to go to the previous submenu.	• The submenu TOTAL shows	The PROG/ENTER key is used as a ◀ key.

The SELECT/▲ key and the CLEAR/▶ key are used for navigation.

The explanation assumes that you are in the submenu TOTAL. When you are:

- in the first setting and you navigate to the previous setting, the F126-P goes back to the related main menu.
- in the last setting and you navigate to the next setting, the F126-P goes to the related main menu.

Action	Result	Remark
1 Press the SELECT/▲ key to select the first setting.	• The setting UNIT shows.	-
2 Press the SELECT/▲ key again to go to the next setting.	• The setting DECIMALS shows.	-
3 Press the CLEAR/▶ key to select the previous setting.	• The setting UNIT shows.	-
4 Press the CLEAR/▶ key again to go to the previous setting.	• The submenu TOTAL shows	This is normal behavior because the setting UNIT is the first setting of the submenu TOTAL.

**How to make a setting**



Caution!

Changes are only saved when you press the PROG/ENTER key.



The explanation assumes that you are in the submenu TOTAL and the setting UNIT. When you do not want to save the change, wait for approximately 20 seconds or press and hold the PROG/ENTER key for approximately 3 seconds.

Action	Result	Remark
1 Momentarily, press the PROG/ENTER key.	• The PROG indicator blinks. • The engineering unit L shows.	To access the setting.
2 Press the SELECT/▲ key to select the next engineering unit.	• The PROG indicator blinks. • The engineering unit m <sup>3</sup> shows.	If you wait too long, the program mode goes off and changes are not saved, this is normal behavior.
3 Press the SELECT/▲ key to select the next engineering unit.	• The PROG indicator blinks. • The engineering unit US GAL shows.	-
4 Press the CLEAR/▶ key to select the previous engineering unit	• The PROG indicator blinks. • The engineering unit m <sup>3</sup> shows.	-
5 To confirm the changes: Momentarily, press the PROG/ENTER key.	• The PROG indicator goes off. • The change is saved. • The engineering unit m <sup>3</sup> shows.	If you do not press the PROG/ENTER key to confirm, your selection is not saved.
To discard the changes: Press and hold the PROG/ENTER key for approximately 3 seconds.	• The PROG indicator goes off. • The change is discarded. • The engineering unit L shows.	-

## 3.1.2. SETUP MENU - SETTINGS



<b>1</b>	<b>TOTAL</b>		
	11	unit	L; m <sup>3</sup> ; kg; lb; GAL; USGAL; bbl; no unit
	12	decimals	0000000; 111111.1; 22222.22; 3333.333
	13	K-Factor:	0.000010 - 9999999
	14	decimals K-Factor	0 - 6
<b>2</b>	<b>FLOW RATE</b>		
	21	unit	mL; L; m <sup>3</sup> ; mg; g; kg; ton; gal; bbl; lb; cf; rev; - - - - (no unit); scf; nm <sup>3</sup> ; nL; p
	22	time	/sec; /min; /hour; /day
	23	decimals	0000000; 111111.1; 22222.22; 3333.333
	24	K-Factor	0.000010 - 9999999
	25	decimals K-Factor	0 - 6
	26	filter	0 - 99
	27	period	0.1 - 99.9 seconds
<b>3</b>	<b>DISPLAY</b>		
	31	function	total; rate
	32	light	0% (off); 20%; 40%; 60%;- 80%; 100% (full brightness)
<b>4</b>	<b>POWER MANAGEMENT</b>		
	41	LCD new	fast; 1 sec; 3 sec; 15 sec; 30 sec; off
	42	battery mode	operational; shelf
<b>5</b>	<b>FLOWMETER</b>		
	51	signal	nnp; npn-lp; reed; reed-lp; pnp; pnp-lp; namur; coil-hi; coil-lo; 8-1 DC; 12 DC; 24 DC
<b>6</b>	<b>TEMPERATURE</b>		
	61	display	°C; °F; K
	62	no. of wires	2; 3
	63	filter	01 - 99
<b>7</b>	<b>FORMULA</b>		
	71	equations type	EL (fixed)
	72	thermal expansion coefficient	0.000000 - 9.999999 (*10-3/K)
	73	t-normal (temp)	0.00 - 99999.99 K
<b>8</b>	<b>ANALOG</b>		
	81	output	disable; enable
	82	rate-min	000.000 - 999999
	83	rate-max	000.000 - 999999
	84	cut-off	0.0 - 9.9%
	85	tune-min	0 - 9999
	86	tune-max	0 - 9999
	87	filter	01 - 99
<b>9</b>	<b>PULSE</b>		
	91	width	0.001 - 9
	92	decimals	0000000; 111111.1; 22222.22; 3333.333
	93	amount	0.001 - 9999999
<b>A</b>	<b>COMMUNICATION</b>		
	A1	speed	1200; 2400; 4800; 9600
	A2	address	1 - 247
	A3	mode	bus-rtu; bus-asc; off
<b>B</b>	<b>OTHERS</b>		
	B1	model	F126-P
	B2	software version	nn:nn:nn
	B3	serial no.	nnnnnnn
	B4	password	0000 - 9999
	B5	tag-nr	0000000 - 9999999

## 3.1.3. EXPLANATION OF SETUP MENU 1 - TOTAL

<b>UNIT</b> 11	This setting is used to select the engineering unit for the indication of the total, the accumulated total and the pulse output.
 Note !	<b><i>When you change the engineering unit, you must recalculate and reprogram the K-factor for the (accumulated) total. When you recalculate and reprogram the K-Factor, the history for (accumulated) total is not correct anymore, because the (accumulated) total is not recalculated. For future reference, best practice is to make a note of the accumulated total before you program the recalculated K-Factor.</i></b>
<b>DECIMALS</b> 12	This setting is used to set the amount of digits behind the decimal point for the (accumulated) total indication.
<b>K-FACTOR</b> 13	This setting is used to set the K-Factor for the total. With the K-Factor, the flowmeter pulse signals are converted to a quantity. The K-Factor is based on the number of pulses generated by the flowmeter per selected engineering unit, for example per m <sup>3</sup> . A more accurate K-Factor (more decimals, as set in decimals K-Factor) allows for a more accurate operation of the system. <b>Example 1: Calculating the K-Factor.</b> The flowmeter generates 2.4813 pulses per liter and the selected unit is m <sup>3</sup> . A cubic meter consists of 1000 liter which gives 2.4813 pulses*1000 liter=2481.3 pulses per m <sup>3</sup> . So, the K-Factor is 2481.3. Enter for the Flowmeter K-Factor: 24813 and for the flowmeter K-Factor decimals: 1. <b>Example 2: Calculating the K-Factor.</b> The flowmeter generates 6.5231 pulses per gallon and the selected engineering unit is gallons. So, the K-Factor is 6.5231. Enter for the Flowmeter K-Factor: 65231 and for the Flowmeter K-Factor decimals: 4.
 Note !	<b><i>When you recalculate and reprogram a new K-Factor, the history for (accumulated) total is not correct anymore, because the (accumulated) total is not recalculated. For future reference, best practice is to make a note of the accumulated total before you program the recalculated K-Factor.</i></b>
<b>DECIMALS K-FACTOR</b> 14	This setting is used to set the amount of digits behind the decimal point for the K-Factor.

## 3.1.4. EXPLANATION OF SETUP MENU 2 - FLOW RATE

The settings for total and flow rate are entirely separate. In this way, different engineering units can be used for each e.g. cubic meters for total and liters for flow rate.

<b>UNIT</b> 21	This setting is used to select the engineering unit for the indication of the flow rate.
 Note !	<b><i>Alteration of the engineering unit will have consequences for operator and setup values, they will not be automatically recalculated to the value of the new selected unit. The K-Factor has to be adapted as well; the calculation is not done automatically.</i></b>
<b>TIME</b> 22	This setting is used to set the time unit for the flow rate calculation. Note that the flow rate is given in engineering unit/time unit, e.g. liters/minute (l/min).  Note ! <i>When you change this setting, also recalculate and change the settings for the analog rate-min and analog rate-max.</i>
<b>DECIMALS</b> 23	This setting is used to set the amount of digits behind the decimal point for the flow rate indication.
<b>K-FACTOR</b> 24	This setting is used to set the K-Factor for the flow rate. With the K-Factor, the flowmeter pulse signals are converted to a quantity. The K-Factor is based on the number of pulses generated by the flowmeter per selected engineering unit, for example per m <sup>3</sup> . A more accurate K-Factor (more decimals, as set in decimals K-Factor) allows for a more accurate operation of the system.
<b>DECIMALS K-FACTOR</b> 25	This setting is used to set the amount of digits behind the decimal point for the K-Factor.

<b>FILTER</b> <b>26</b>	<p>This setting is used to stabilize the flow rate reading. With the help of this digital filter a more stable but less actual reading can be obtained. The filter principal is based on three input values: the filter level (01-99), the last calculated flow rate and the last average value. The higher the filter level, the longer the response time on a value change will be. In practice it is best to use trial and error to find the best setting for your application.</p>
<b>PERIOD</b> <b>27</b>  Note !	<p>This setting is used to calculate the flow rate by counting the number of pulses within a certain time, for example 1 second. The longer the time the more accurate the flow rate will be.</p> <ul style="list-style-type: none"> <li>• <i>this setting does influence the update time for the analog output directly. If the output response is too slow, decrease the number of pulses.</i></li> <li>• <i>the shorter the update time, the higher the power consumption of the unit will be (important for battery powered applications).</i></li> </ul>

### 3.1.5. EXPLANATION OF SETUP MENU 3 - DISPLAY

<b>FUNCTION</b> <b>31</b>	<p>This setting can be set to display total or rate.</p> <ul style="list-style-type: none"> <li>• <i>When 'total' is selected, simultaneously, total is shown with the large digits and flow rate with the smaller digits. When SELECT is pressed, the accumulated total is shown temporarily.</i></li> <li>• <i>When 'rate' is selected, only flow rate will be shown with the large digits together with its measuring unit. When SELECT is pressed, the total and the accumulated total are shown temporarily.</i></li> </ul>
<b>LIGHT</b> <b>32</b>	<p>The backlight brightness can be adjusted from 0% (off) to 100% (full brightness) in steps of 20%. When the F126-P is only loop powered, the backlight is disabled. An external power supply is required to supply the backlight.</p>

### 3.1.6. EXPLANATION OF SETUP MENU 4 - POWER MANAGEMENT

When used with the internal battery option (type PB/PC), the user can expect reliable measurement over a long period of time. The F126-P has several smart power management functions to extend the battery life time significantly. Two of these functions can be set.

<b>LCD NEW</b> <b>41</b>	<p>The calculation of the display-information influences the power consumption significantly. When the application does not require a fast display refresh rate, it is strongly advised to select a slow refresh rate. Please understand that NO information will be lost; every pulse will be counted and the output signals will be generated in the normal way. At a key press, the display refresh rate will switch to FAST for 30 seconds. When 'OFF' is selected, the display goes off after 30 seconds after the last key press. The display temporarily comes on after a key press.</p> <p><b>Example battery life-time with a coil pick-up:</b></p> <ul style="list-style-type: none"> <li>• 1kHz pulse and FAST update: about 2 years;</li> <li>• 1kHz pulse and 1 sec update: about 5 years.</li> </ul>
<b>BATTERY MODE</b> <b>42</b>	<p>The F126-P has two modes: operational or shelf. After "shelf" has been selected, the F126-P can be stored for several years; it will not process the sensor signal; the display is switched off but all settings and totals are stored. In this mode, power consumption is extremely low. To wake up the F126-P again, press the SELECT/▲ key two times.</p>

## 3.1.7. EXPLANATION OF SETUP MENU 5 - FLOWMETER

<b>SIGNAL 51</b>	With this setting the type of flowmeter output is selected. The settings with LP (low-pass) filter are used to apply a build-in noise reduction. <i>Selections "active pulse" offer a detection level of 50% of the supply voltage.</i>				
TYPE OF SIGNAL	Note !	EXPLANATION	RESISTANCE	FREQ. / mV	REMARK
NPN		NPN input	100 kΩ pull-up	max. 6 kHz.	(open collector)
NPN-LP		NPN with low pass filter	100 kΩ pull-up	max. 1.2 kHz.	(open collector) less sensitive
REED		Reed-switch input	1 MΩ pull-up	max. 600 Hz.	
REED-LP		Reed-with low pass filter	1 MΩ pull-up	max. 120 Hz.	Less sensitive
PNP		PNP input	100 kΩ pull-down	max. 6 kHz.	
PNP-LP		PNP with low pass filter	100 kΩ pull-down	max. 1.2 kHz.	Less sensitive
NAMUR		NAMUR input	820 Ω pull-down	max. 4 kHz.	External power required
COIL-HI		High sensitive coil input	-	min. 20 mV <sub>pp</sub>	Sensitive for interference!
COIL-HI (option ZF)	min. 10 mV <sub>pp</sub>				
COIL-HI (option ZG)	min. 5 mV <sub>pp</sub>				
COIL-LO		Low sensitive coil input	-	min. 80 mV <sub>pp</sub>	Normal sensitivity
8-1 DC		Active pulse input detection level 8.2V DC	3.9 kΩ	max. 10 kHz.	External power required
12 DC		Active pulse input detection level 12V DC	4 kΩ	max. 10 kHz.	External power required
24 DC		Active pulse input detection level 24V DC	3 kΩ	max. 10 kHz.	External power required

## 3.1.8. EXPLANATION OF SETUP MENU 6 - TEMPERATURE

<b>DISPLAY 61</b>	This setting is used to program the temperature unit which is shown to the operator. This setting does not influence the actual calculations.				
<b>NO. OF WIRES 62</b>	This setting is used to program the number of wires for the PT100 sensors.				
<b>FILTER 63</b>	The analog output signal of a sensor represents the actual temperature. This signal is measured several times a second. The value measured is a "snap-shot" of the real temperature as it will be fluctuating. With the help of this digital filter a stable and accurate reading can be obtained while the filter level can be set to a desired value. The filter principal is based on three input values: the filter level (01-99), the last measured analog value and the last average value. The higher the filter level, the longer the response time on a value change will be.				
<b>Filter value</b>	<b>Response time on step change of analog value. (Time in seconds).</b>				
<b>influence</b>	<b>50%</b>	<b>75%</b>	<b>90%</b>	<b>99%</b>	
<b>01</b>	filter disabled	filter disabled	filter disabled	filter disabled	
<b>10</b>	14 sec	28 sec	44 sec	88 sec	
<b>20</b>	28 sec	56 sec	90 sec	180 sec	
<b>30</b>	42 sec	82 sec	136 sec	272 sec	
<b>50</b>	70 sec	136 sec	228 sec	456 sec	
<b>75</b>	104 sec	208 sec	344 sec	688 sec	
<b>99</b>	136 sec	274 sec	454 sec	908 sec	







## 3.1.9. EXPLANATION OF SETUP MENU 7 - FORMULA

<b>EQUATIONS TYPE</b> 71	This setting shows the formula. The type EL stands for Equations Liquid - flow computer for corrected liquid volume. The formula use[d] $Q_{normal} = Q * (1 + \alpha (T_{normal} - T))$ where: <b>Q<sub>normal</sub></b> : calculated volume at reference conditions <b>Q</b> : measured volume <b>α</b> : thermal expansion coefficient <b>T<sub>normal</sub></b> : reference temperature <b>T</b> : measured temperature
<b>THERMAL EXPANSION COEFFICIENT</b> 72	Enter here the thermal expansion coefficient $\alpha$ for the liquid used. The value to be entered has to be multiplied with 1000. The decimal position is fixed but cannot be shown: x,xxxxxx. With the default value of 0.000000 the volume correction is <u>disabled</u> . <b>Examples: Calculation of the thermal expansion coefficient</b> $\alpha$ for water is 0,00031 per K. Enter: 0310000. $\alpha$ for petrol is 0,00110 per K. Enter: 1100000.
<b>NORMAL TEMPERATURE</b> 73	Enter here the reference temperature $T_{normal}$ in degrees Kelvin (K). In most applications, the volume has to be calculated at 15°C which is 288,15 K.

## 3.1.10. EXPLANATION OF SETUP MENU 8 - ANALOG

A linear 4-20mA signal (option AB: 0-20mA or option AU: 0-10V) output signal is generated that represents the flow rate. The settings for the flow rate influence the analog output directly. The relationship between the flow rate and the analog output is set with the following settings.

<b>OUTPUT</b> 81  	If the analog output is not used, select disable to minimize the power consumption (e.g. save battery life-time). <i>Option AP: When a power supply is available but the output is disabled, a 3.5mA signal will be generated.</i>
<b>RATE-MIN</b> 82	Enter here the flow rate at which the output should generate the minimum signal (0)4mA or 0V - in most applications at zero flow. The number of decimals shown depend upon setup 23. The engineering units/time (e.g. L/min) are dependent upon setup 21 and 22.
<b>RATE-MAX</b> 83	Enter here the flow rate at which the output should generate the maximum signal (20mA or 10V) - in most applications at maximum flow. The number of decimals shown depend upon setup 23. The engineering units/time (e.g. L/min) are dependent upon setup 21 and 22.
<b>CUT-OFF</b> 84	To ignore leakage of the flow for example, a low flow cut-off can be set as a percentage of the full range of 16mA, 20mA or 10V. When the flow is less than the required rate, the current will be the minimum signal (0)4mA or 0V. <b>Example:</b> Calculate the cut-off. Rate-min: 0L/min [4mA], Rate-max: 100 L/min [16mA], Cut-off: 2% <b>Required rate [L/min]:</b> (rate-max - rate-min)*cut-off: (100-0)*2%=2.0L/min <b>Output [mA]:</b> rate-min + (rate-max*cut-off): 4+(16*2%)=4.32mA
<b>TUNE-MIN</b> 85    	The (0)4mA or 0V value can be tuned precisely with this setting. The initial minimum analog output value is (0)4mA or 0V. However, this value might differ slightly due to ambient influences such as temperature for example. <b>Before tuning the signal, make sure that the analog signal is idle (not used) for any application!</b> After pressing PROG, the current will be about 4mA (0mA or 0V). The current can be increased / decreased with the arrow keys and is directly active. Press ENTER to store the new value. <i>If required, you can program the analog output 'up-side-down'. The (0)4mA or 0V represents the maximum flow rate and the 20mA or 10V represents the minimum flow rate.</i>

<b>TUNE-MAX</b> <b>86</b>    	<p>The 20mA or 10V value can be tuned precisely with this setting. The initial maximum analog output value is 20mA or 10V. However, this value might differ slightly due to ambient influences such as temperature for example.</p> <p><b>Before tuning the signal, make sure that the analog signal is idle (not used) for any application!</b></p> <p>After pressing PROG, the current will be about 20mA or 10V. The current can be increased / decreased with the arrow keys and is directly active. Press ENTER to store the new value.</p> <p><i>If required, you can program the analog output 'up-side-down'. The (0)4mA or 0V represents the maximum flow rate and the 20mA or 10V represents the minimum flow rate.</i></p>
--	---

<b>FILTER</b> <b>87</b>	<p>This setting is used to stabilize the output signal. With the help of this digital filter a more stable but less actual representation of the flow rate can be obtained.</p> <p>The filter principal is based on three input values: the filter level (01-99), the last calculated flow rate and the last average value. The higher the filter level, the longer the response time on a value change will be.</p>
----------------------------	--

Filter value		Response time on step change of analog value. (Time in seconds)			
INFLUENCE	50%	75%	90%	99%	
01	filter disabled	filter disabled	filter disabled	filter disabled	
02	0.1 sec	0.3 sec	0.5 sec	0.9 sec	
03	0.3 sec	0.5 sec	0.7 sec	1.5 sec	
05	0.5 sec	0.9 sec	1.5 sec	2.6 sec	
10	0.9 sec	1.8 sec	2.8 sec	5.5 sec	
20	1.75 sec	3.5 sec	5.6 sec	11.25 sec	
30	2.6 sec	5 sec	8.8 sec	17.5 sec	
50	4.4 sec	8.8 sec	13.8 sec	28.8 sec	
75	6.5 sec	12.5 sec	21.25 sec	4.25 sec	
99	8.6 sec	17.5 sec	28.75 sec	56.25 sec	

**3.1.11. EXPLANATION OF SETUP MENU 9 - PULSE**

Two transistor or mechanic relay outputs are available as scaled pulse output according to the total.

<b>WIDTH</b> <b>91</b>	<p>The pulse width determines the time that the output will be active; in other words the pulse duration. Value “zero” will disable the pulse output.</p> <p>The pulse signal always has a 50% duty cycle, hence the minimum time between the pulses is equal to the pulse width setting. If the frequency should go out of range – when the flow rate increases for example – an internal buffer will be used to “store the missed pulses”: As soon as the flow rate slows down, the buffer will be “emptied”.</p> <p>It might be that pulses will be missed due to a buffer-overflow, so it is advised to program this setting within its range!</p>
<b>DECIMALS</b> <b>92</b>	<p>This setting is used to set the amount of digits behind the decimal point for the amount.</p>
<b>AMOUNT</b> <b>93</b>	<p>A pulse will be generated every time a certain quantity is added to the total. Enter this quantity here while taking the decimals for pulse into account.</p>



**3.1.12. EXPLANATION OF SETUP MENU A - COMMUNICATION (OPTION)**

*This product is designed for the connection to a communication network. Products with a communication option do not include cyber security functions. Fluidwell cannot take any responsibility for the cyber security, omissions or errors in the communication safety. To maintain a secure operation, automation and control, it is the sole responsibility of the owner to install and manage the appropriate safety measures to protect the network, the product and the communication against any kind of security breaches.*

The functions described below deal with hardware that is not part of the standard delivery. Programming of these functions does not have any effect if this hardware has not been installed. Consult Appendix C and the Modbus communication protocol description for a detailed explanation.

<b>SPEED A1</b>	This setting is used to set the Baudrate.
<b>ADDRESS A2</b>	This setting is used to set the communication address for the F126-P.
<b>MODE A3</b>	This setting is used to set the Modbus transmission mode. Select OFF to disable the communication.

**3.1.13. EXPLANATION OF SETUP MENU B - OTHERS**

For support and maintenance it is important to have information about the characteristics of the F126-P. Your supplier will ask for this information when support is required.

<b>MODEL B1</b>	This setting shows the model name.
<b>SOFTWARE VERSION B2</b>	This setting shows the version number of the firmware (software).
<b>SERIAL NO. B3</b>	This setting shows the serial number.
<b>PASSWORD B4</b>	This setting is used to set a password (pin code) to limit the access for the setup menu. Only persons who know the pin code can access the setup menu. The pin code 0000 disables the pin code to allow for access by any person.
<b>TAG-NR B5</b>	This setting is used to set a tag number for the F126-P.

## 4. INSTALLATION

### 4.1. GENERAL DIRECTIONS



- Mounting, electrical installation, start-up and maintenance of this device may only be carried out by trained persons authorized by the operator of the facility. Persons must read and understand this manual before carrying out its instructions.
- This device may only be operated by persons who are authorized and trained by the operator of the facility. All instructions in this manual are to be observed.
- Make sure, the measuring system is correctly wired up according to the wiring diagrams. Protection against accidental contact is no longer assured when the housing cover is removed or the panel cabinet has been opened (danger from electrical shock). The housing may only be opened by trained persons authorized by the operator of the facility.
- Take careful notice of the "Safety rules, instructions and precautionary measures" at the front of this manual.

### 4.2. INSTALLATION - SURROUNDING CONDITIONS

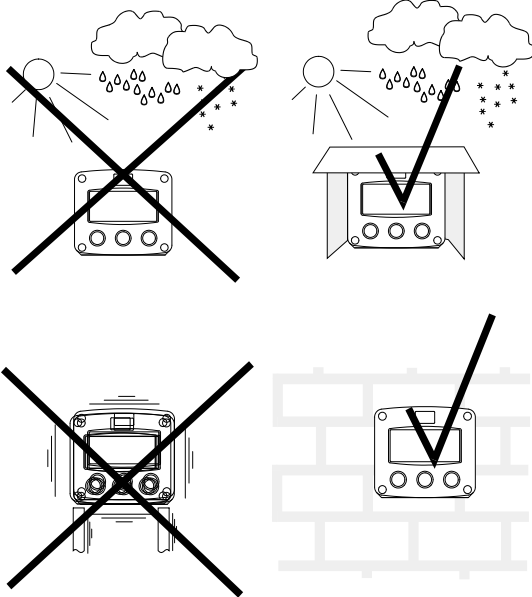

Take the relevant IP classification of the enclosure into account (see identification plate). Even an enclosure rated for IP67 / TYPE 4(X) should NEVER be exposed to strongly varying (weather) conditions.

**When panel-mounted, the front panel of the F126-P is rated for IP65 / TYPE 4(X)!**

When used in very cold surroundings or varying climatic conditions, inside the instrument case, take the necessary precautions against moisture.

Mount the F126-P onto a solid structure to avoid vibrations.

4.3. DIMENSIONS- ENCLOSURE

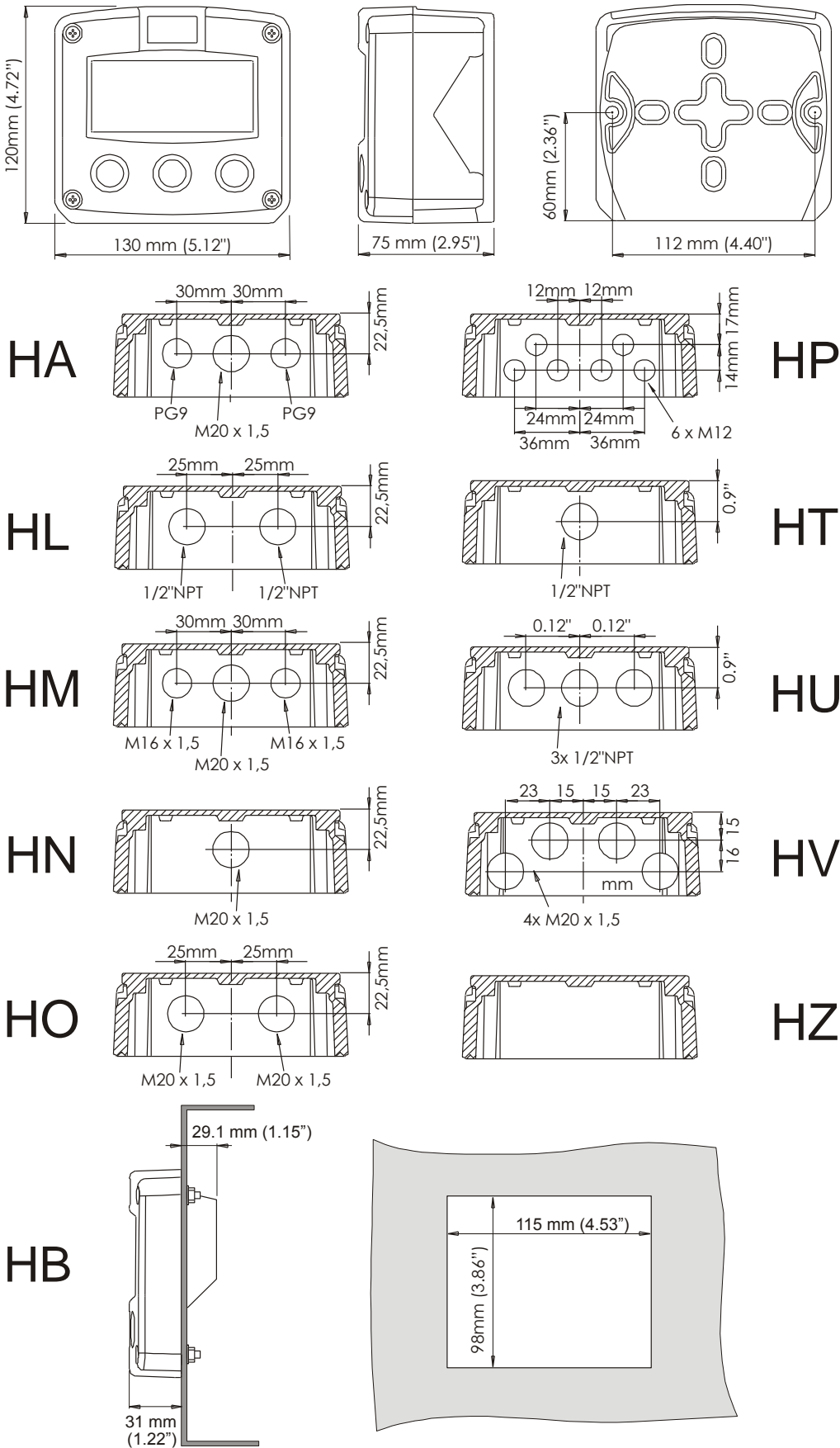
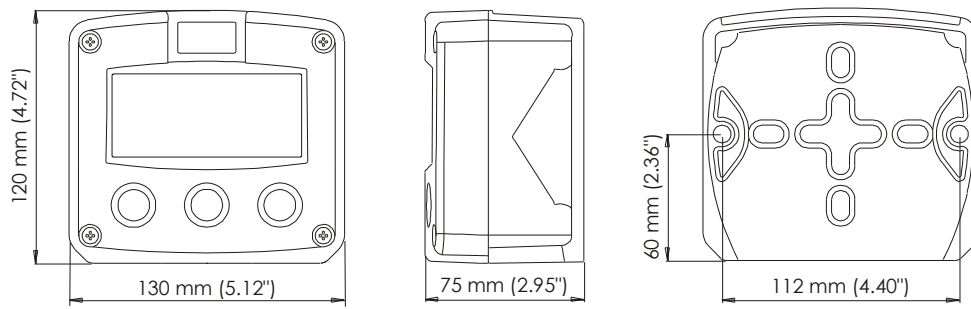
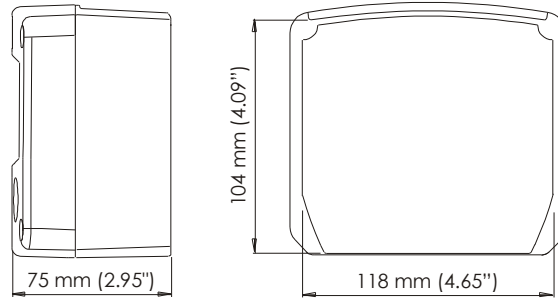

Fig. 5: Aluminum enclosures - Dimensions



HK back box:  
(flat bottom)



HD  
HK

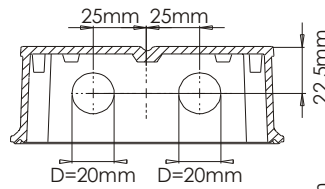
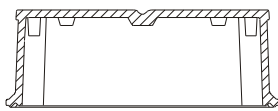

HG

HE

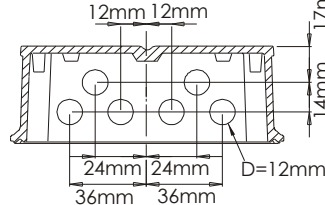
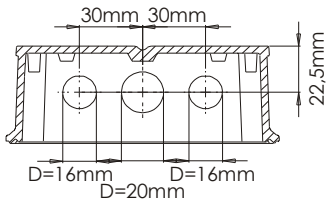

HH

HF

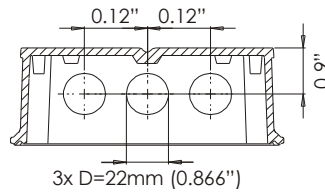
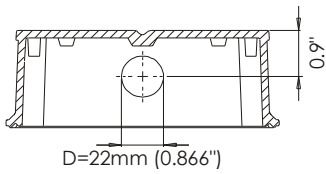

HJ

HC

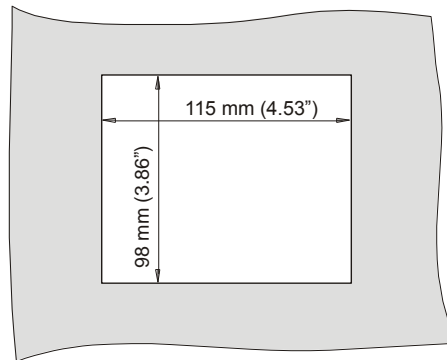
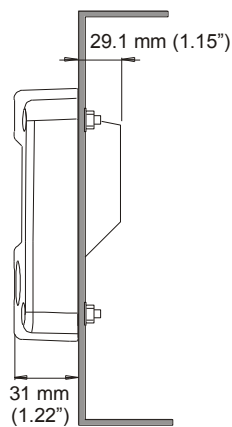

Fig. 6: GRP enclosures - Dimensions

#### 4.4. INSTALLING THE HARDWARE



- Electro static discharge does inflict irreparable damage to electronics! Before installing or opening the F126-P, the installer has to discharge himself by touching a well-grounded object.
- Do ground the aluminum enclosure properly as indicated. It is the responsibility of the installer to install, connect and test the Protective Earth connections in accordance with the (inter)national Rules and Regulations.
- This chapter shows general information regarding the electrical installation of the F126-P. Chapter 5 gives additional specific information regarding Intrinsically safe installation and overrules the information given in this chapter.



- When installed in an aluminum enclosure and a potentially explosive atmosphere requiring apparatus of equipment protection level Ga and Da, the unit must be installed such that, even in the event of rare incidents, an ignition source due to impact or friction sparks between the enclosure and iron/steel is excluded.

##### 4.4.1. GENERAL INSTALLATION GUIDELINES

- In the F126-P, different types of bonding and earthing are used. The common (ground) is mostly used for termination of the wire shields and the Protective Earth (PE) is used for electrical safety.
- The F126-P that came with a power module type PM; 110V-230V AC or type PD/PF with an option OR (the relays can handle 110V-230V AC) shall be connected to the Protective Earth (PE) stud which is installed in the metal back panel. The metal front panel is connected to the Protective Earth by the mounting screws and serrated washers.
- For V AC applications, the terminal 00 shall not be connected to avoid earth loops. For V DC applications, the terminal 00 shall be connected to the common (do NOT use for PE).
- The wire screens (shield) are meant to prevent electromagnetic interference and shall be, galvanic isolated, connected to the common ground terminals that belong to the specific sensor connection. The wire screens shall be terminated at one side to prevent wire loops. Inside of the Fluidwell unit, the different common ground terminals are connected to each other. It is advised, as illustrated, to terminate the wire screens in the vicinity of the sensor and to insulated the wire screen with a shrink tube at the Fluidwell unit side.
- Separate cable glands with effective IP67 / TYPE 4(X) seals for all wires.
- Unused cable entries: ensure that you fit IP67 / TYPE 4(X) plugs to maintain rating.
- A reliable ground connection for both the sensor, and if applicable, for the metal enclosure (above).
- An effective screened cable for the input signal, and grounding of its screen to the “⊥” terminal or at the sensor itself, whichever is appropriate to the application.

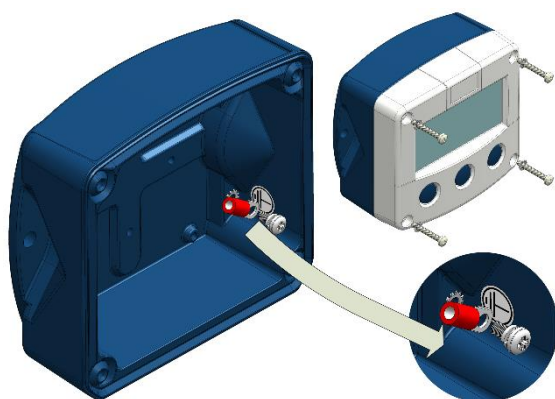

Field mounted

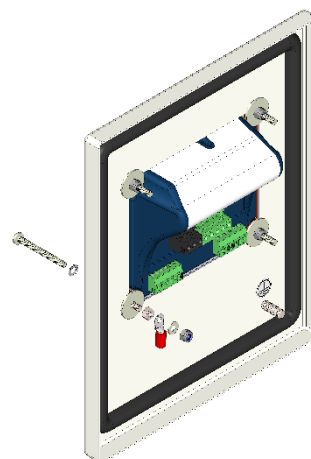

Panel mounted

4.4.2. ALUMINUM ENCLOSURE - FIELD MOUNTED



**Risk of damage to equipment!**

Do not use the terminal 00 to connect the protective earth wire, the 00 and the common ground terminals are internally connected. Be careful, to prevent damage to equipment when you connect different power supplies (sensor, PLC, etc.). Inside the Fluidwell display, the common grounds are internally connected to each other.

**The PE connection**

The PE connection is made with the PE stud inside the back panel and the 4 mounting screws that attach the cover to the back panel.

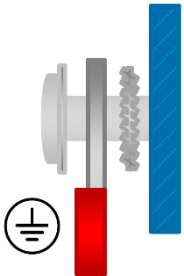

The PE connection in the metal back panel is made with a serrated washer, a terminal, a washer and a screw.

The PE connection to the metal cover is made with the serrated washers and the mounting screws.

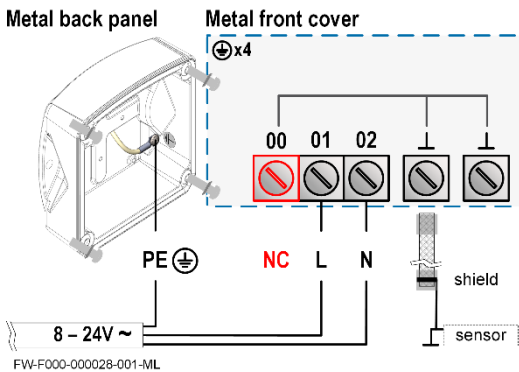

**Type OR (8-24V AC)**

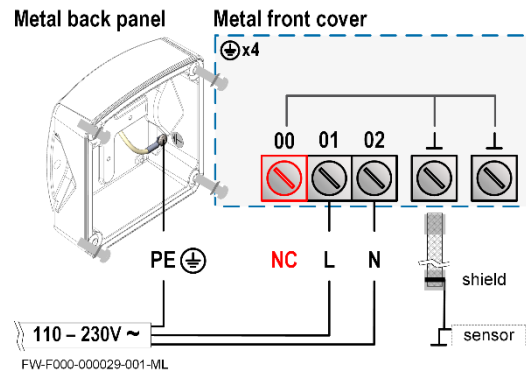

**Type PM (110-230V AC)**

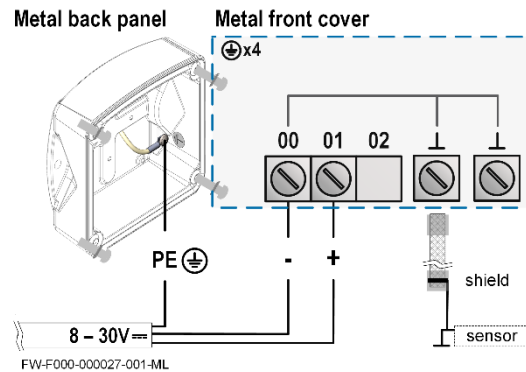

**Type OR (8-30V DC)**

4.4.3. ALUMINUM ENCLOSURE - PANEL MOUNTED

**The PE connection**

The PE connection is made with one of the mounting screws that attaches the front panel to the panel.

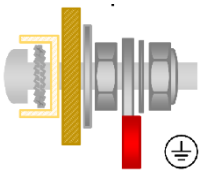

The PE connection to the metal cover is made with the serrated washers and the mounting screws.

The PE connection to the panel is made with the washer, the nut, the terminal, the washer and a lock nut.

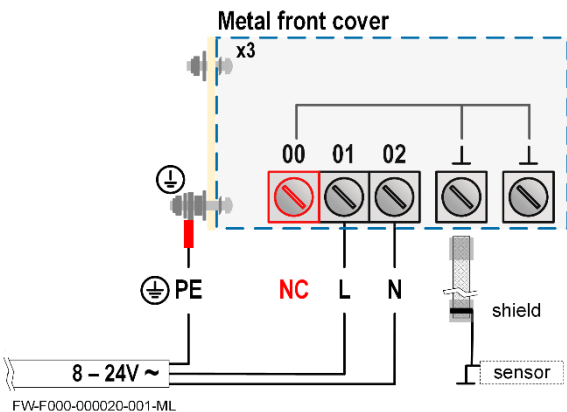

**Type OR (8-24V AC)**

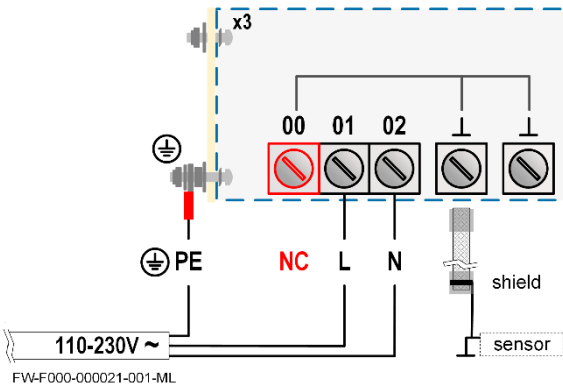

**Type PM (110-230V AC)**

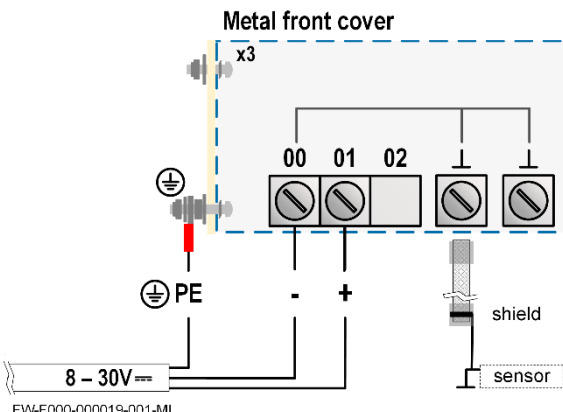

**Type OR (8-30V DC)**

#### 4.4.4. PLASTIC (GRP) ENCLOSURE

##### The PE connection

The F126-P in a GRP enclosure meets the requirements of class 2 (double insulated). Therefore the incoming PE wire is terminated with an insulating end cap.

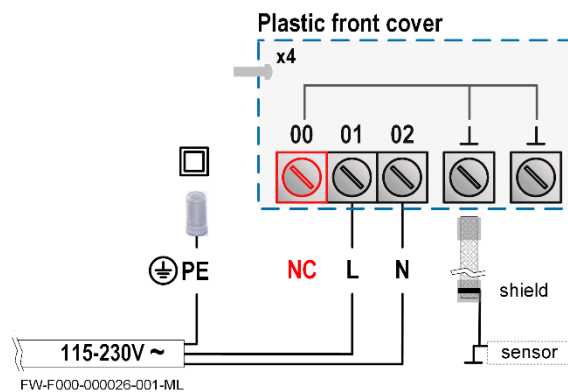

**Type PM (110-230V AC)**

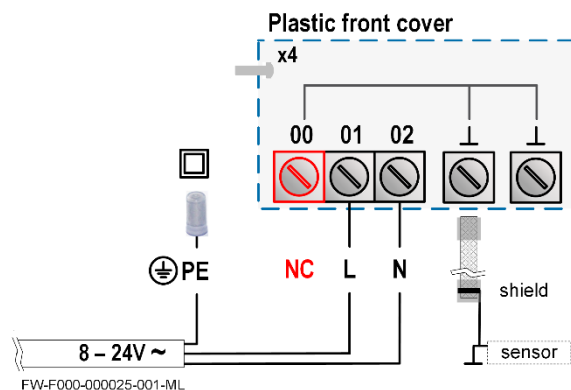

**Type OR (8-24V AC)**

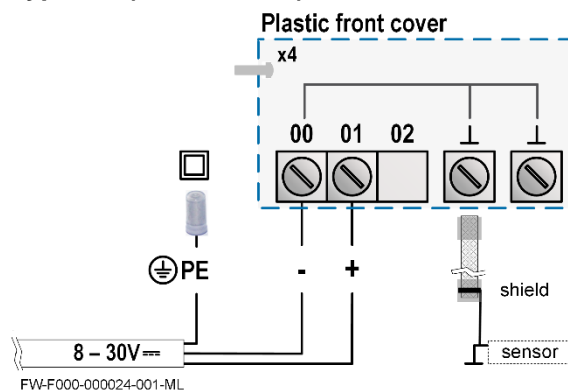

**Type OR (8-30V DC)**

4.4.5. TERMINAL CONNECTORS

Refer to Appendix A: Technical Specification



For *Intrinsically safe* applications: read chapter 5.

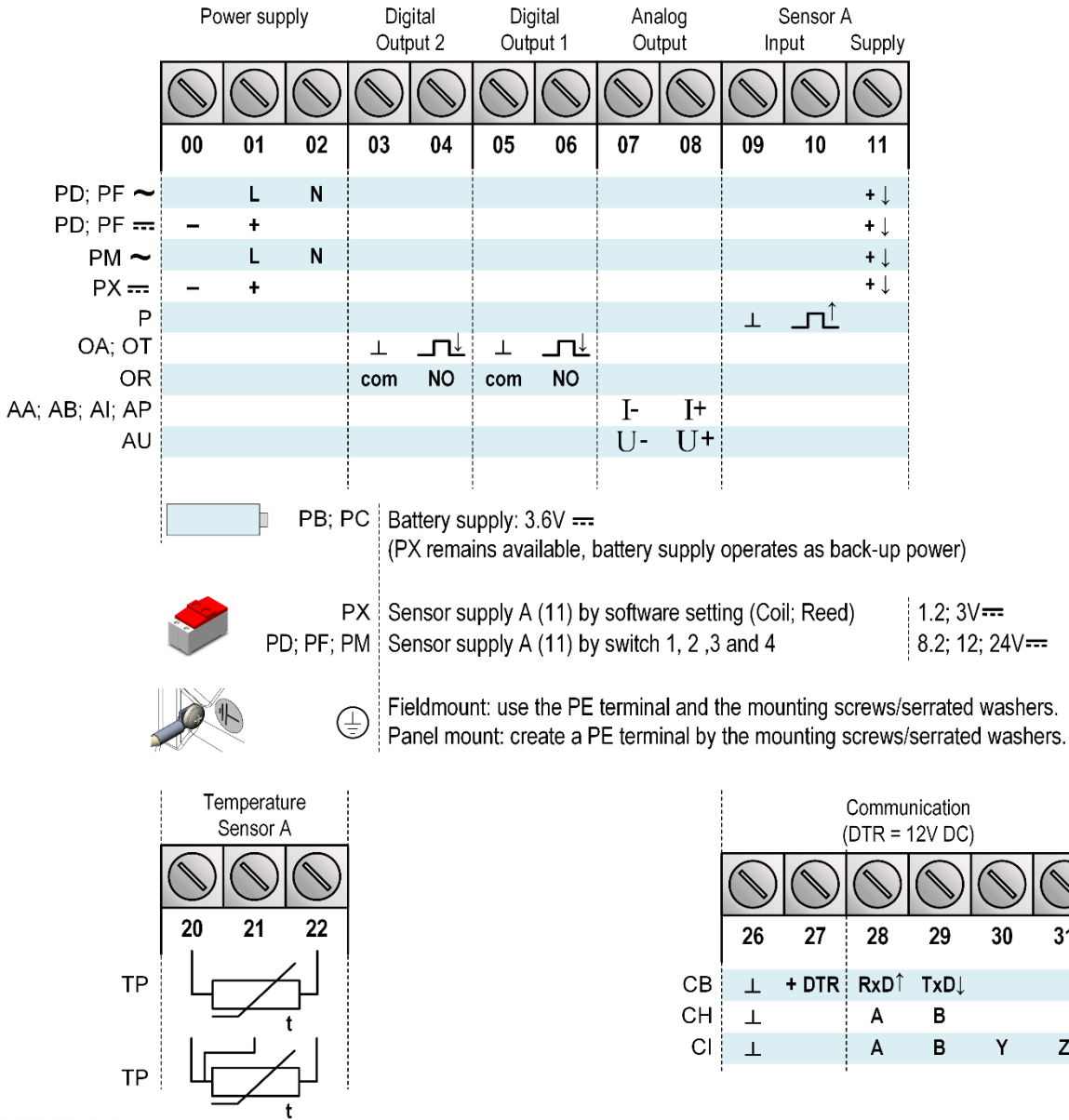

FW-F126-000001-001-EN

Fig. 7: Overview of terminal connectors - Standard configuration and options

4.4.6. VOLTAGE SELECTION SENSOR SUPPLY

**For type PB/PC; PX; AP:** There is no real sensor supply out available. Only a limited power supply is available. This power supply MAY NOT be used to supply the flowmeters electronics, converters etc. as it will not provide adequate sustained power ! All energy used by the flowmeters pick-up will directly influence the battery life-time. It is strongly advised to use a "zero power" pickup such as a coil or reed-switch when operating without external power. It is possible to use some low power NPN or PNP output signals, but the battery life time will be significantly reduced (consult your distributor). The sensor supply is fixed: 1.2V DC or 3V DC (set by the firmware).

**For type PD; PF; PM:** It is possible to supply the sensor with different voltages. You can set the voltage with the switches. Internal power is only applicable for low power sensors (Coil, Reed). External power is only available when the main external power supply is connected. The sensor supply voltage is selectable: 1.2; 3; 8.2; 12 or 24V DC.



### Set the sensor supply

1. Make the F126-P safe. If applicable, mind the battery power.
2. Open the F126-P and carefully remove the cable-connectors and the protective cover.
3. Find and set the switches and select the  $V_{out}$  as required.
4. Close the protective cover and install the cable connectors.
5. Close the F126-P.



#### Risk of electrocution - High voltage!

Make sure, all the leads to the terminals are disconnected from the F126-P and NEVER connect the mains power supply to the unit when the protection cover has been removed!

Type PD	Power supply in: 8-24V AC / 10-30V DC				
<p>FW-PD-000001-001-EN</p> <p>Switch location (typical)</p>	Sensor A		$V_{out}$ selection		Sensor supply out
	1	2	3	4	NOTE: Use an AC autotransformer (spartrafo) with galvanic isolation.
	int	-	off	off	Coil 1.2V DC; <1mA Reed 3V DC; <1mA
	ext	-	on on off	on off off	8.2V DC @8V <sub>in</sub> AC / 10V <sub>in</sub> DC 12V DC @10V <sub>in</sub> AC / 14V <sub>in</sub> DC 24V DC @18V <sub>in</sub> AC / 26V <sub>in</sub> DC
Type PF	Power supply in: 15-24V AC / 20-30V DC				
<p>FW-PFPM-000001-001-EN</p> <p>Switch location (typical)</p>	Sensor A		$V_{out}$ selection		Sensor supply out
	1	2	3	4	
	int	-	off	off	Coil 1.2V DC; <1mA Reed 3V DC; <1mA
	ext	-	on on off	on off off	8.2V DC @8V <sub>in</sub> AC / 10V <sub>in</sub> DC 12V DC @10V <sub>in</sub> AC / 14V <sub>in</sub> DC 24V DC @18V <sub>in</sub> AC / 26V <sub>in</sub> DC
Type PM	Power supply in: 115V - 230V AC				
<p>FW-PFPM-000001-001-EN</p> <p>Switch location (typical)</p>	Sensor A		$V_{out}$ selection		Sensor supply out
	1	2	3	4	
	int	-	off	off	Coil 1.2V DC; <1mA Reed 3V DC; <1mA
	ext	-	on on off	on off off	8.2V DC 12V DC 24V DC

Fig. 8: Sensor supply voltage - Switch setting

#### Terminal 05-06/03-04; scaled pulse output R1/R2:

Setup 9 (read chapter 3) determines the pulse output function. The maximum pulse frequency of this output is 500Hz. If a relay output option has been supplied, be sure that the output frequency does not exceed 5Hz or else the life-time of the relay will be reduced significantly.

**Type OA:**

An active 24V DC pulse signal output is available with this option.  
 Max. driving capacity 50mA@24V per output. (Requires power supply type PD/PF/PM).

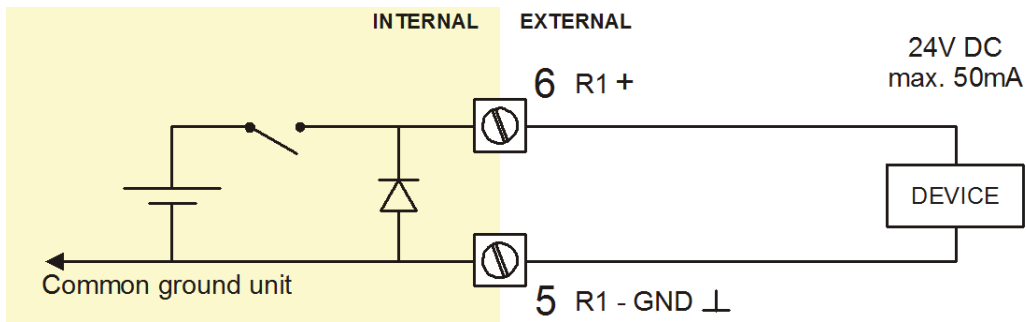

**Fig. 9: Terminal connections - Active output (typical)**

**Type OR:**

A mechanical relay output is available with this option. Max. switch power 240V 0,5A per output.  
 (Requires power supply type PF/PM). Be sure that the output frequency does not exceed 5Hz, else the relay life time will be reduced significantly.

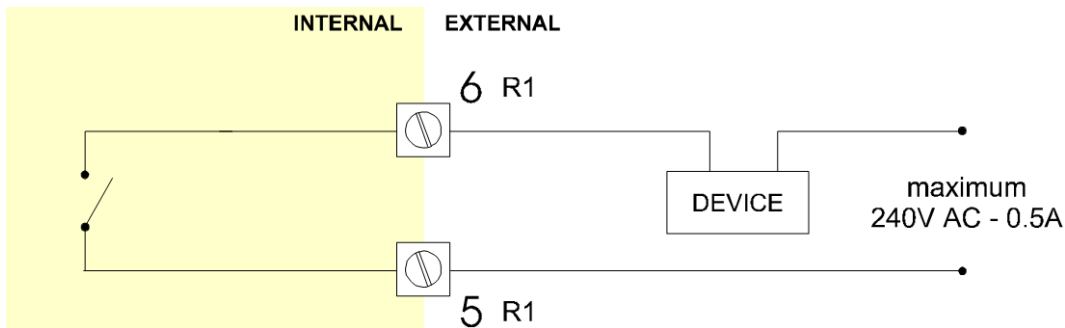

**Fig. 10: Terminal connections - Mechanical relay output (typical)**

**Type OT:**

A passive transistor output is available with this option. Max. driving capacity 300mA@50V DC.

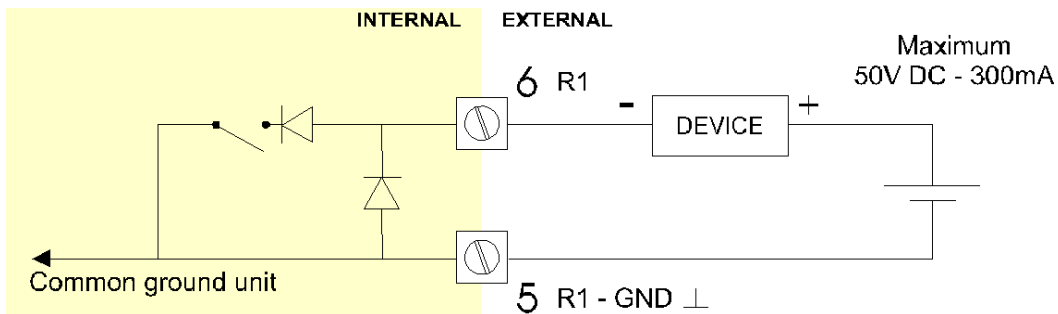

**Fig. 11: Terminal connections - Pulse output (typical)**

**Terminal 07-08; basic POWER SUPPLY - type AP – output loop powered**

Connect an external power supply of 8-30VDC to these terminals or a 4-20mA loop.  
 Do connect the “-“ to terminal 7 and the “+“ to terminal 8. When power is applied to these terminals, the (optional) internal battery will be disabled / enabled automatically to extend the battery life time.

**Terminal 07-08 analog output (setup 7) :**

An analog output signal proportional to the flow rate is available as standard.

**Type AA:**

An active 4-20mA signal proportional to the flow rate is available with this option. When the output is disabled, a 3.5mA signal will be generated on these terminals. Max. driving capacity 1000 Ohm @ 24VDC. (Requires power supply type PD/PF/PM).

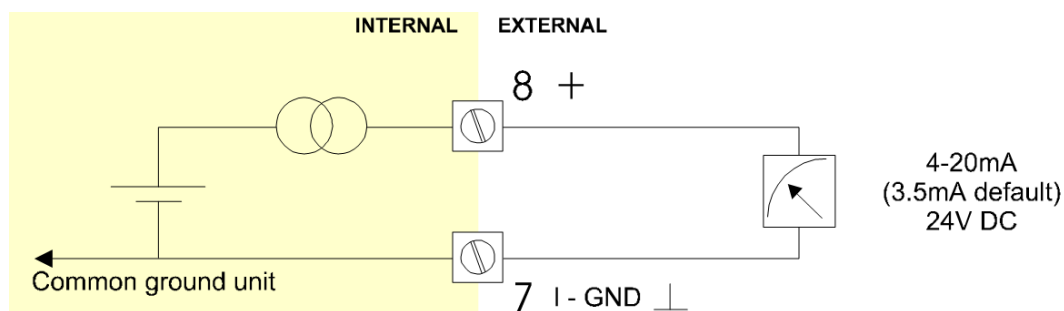

**Fig. 12: Terminal connections - 4-20mA analog output (typical)**

**Type AB:**

An active 0-20mA signal proportional to the flow rate is available with this option. Max. driving capacity 1000 Ohm @ 24VDC. (Requires power supply type PD/PF/PM).

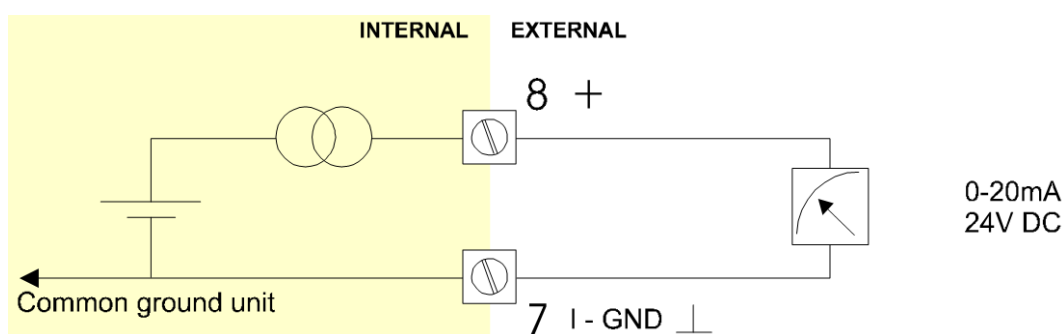

**Fig. 13: Terminal connections - Active 0-20mA analog output (typical)**

**Type AF:**

For the Intrinsically safe floating 4-20mA signal: please read Chapter 5.

**Type AI:**

An isolated 4-20mA signal proportional to the flow rate is available with this option. When the output is disabled, a 3.5mA signal will be generated on these terminals. Max. driving capacity 1000 Ohm @ 30VDC. This option can be used with a battery powered unit but the life time of the battery is about 2 -3 years.

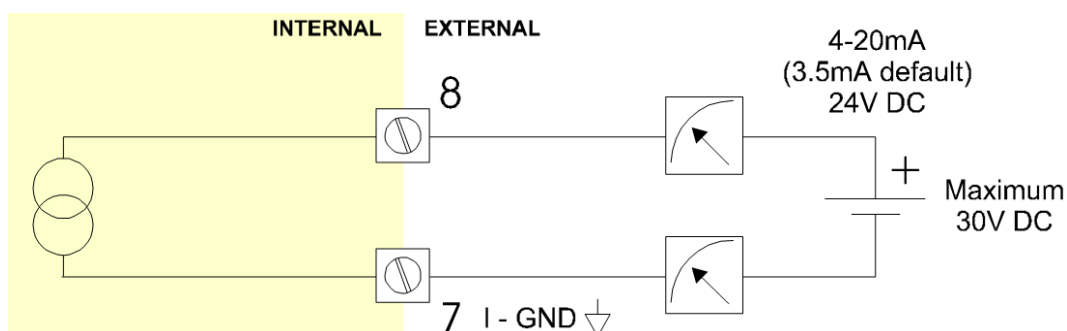

**Fig. 14: Terminal connections - Isolated 4-20mA analog output (typical)**

**Type AP:**

A passive 4-20mA signal proportional to the flow rate is available with this option. When a power supply is connected but the output is disabled, a 3.5mA signal will be generated. Max. driving capacity 1000 Ohm. This output does loop power the unit as well.

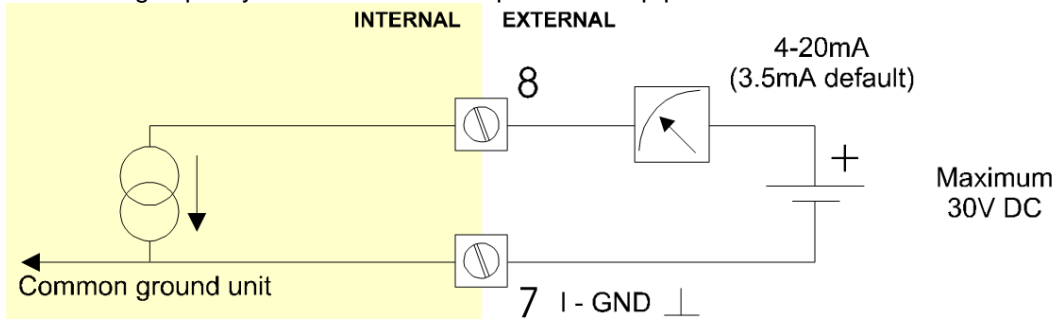

**Fig. 15: Terminal connections - Passive 4-20mA analog output (typical)**

**Type AU:**

A 0-10VDC signal proportional to the flow rate is available with this option. Max. load 10mA @ 10VDC. (Requires power supply type PD/PF/PM).

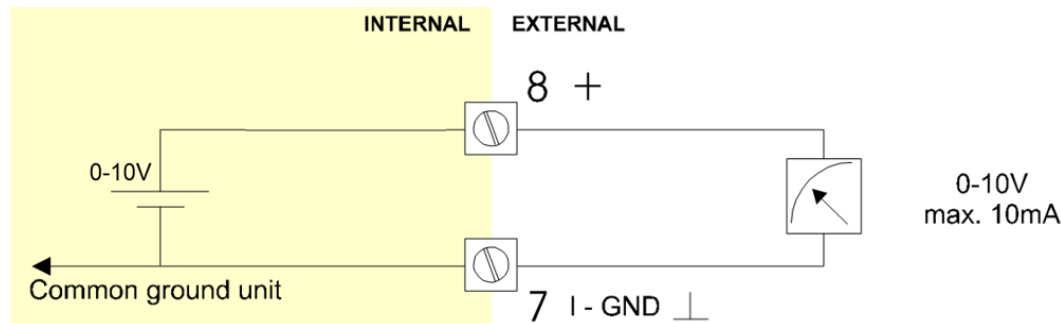

**Fig. 16: Terminal connections - Active 0-10V analog output (typical)**

**Terminal 09-11; Flowmeter input:**

Three basic types of flowmeter signals can be connected to the unit: pulse, active pulse or sine-wave (coil). The screen of the signal wire must be connected to the common ground terminal 09 (unless earthed at the sensor itself).

The maximum input frequency is approximately 10 kHz (depending on the type of signal). The input signal type has to be selected in the flowmeter setup (read chapter 3).

**Sine-wave signal (Coil):**

The F126-P is suitable for use with flowmeters which have a coil output signal.

Two sensitivity levels can be selected:

- COIL-LO: sensitivity from about 80mV<sub>pp</sub>;
- COIL-HI: sensitivity from about 20mV<sub>pp</sub>;
- type ZF, COIL-HI: sensitivity from about 10mV<sub>pp</sub>;
- type ZG, COIL-HI: sensitivity from about 5mV<sub>pp</sub>.

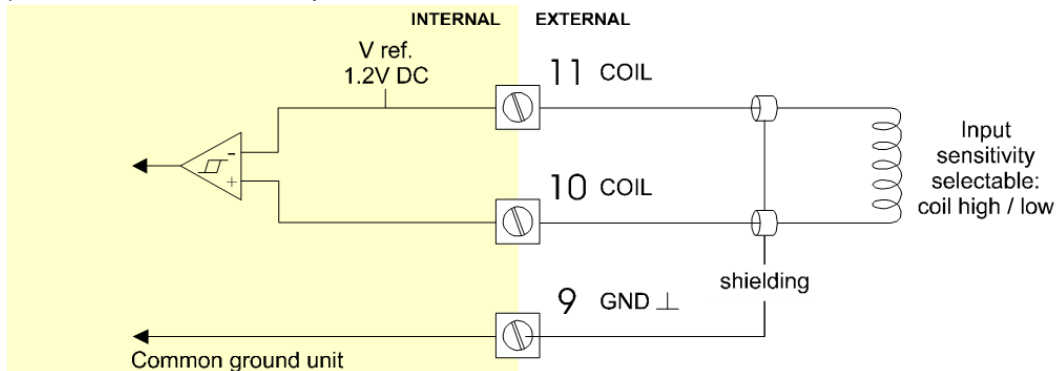

**Fig. 17: Terminal connections - Coil signal input (typical)**

**Pulse-signal NPN / NPN-LP:**

The F126-P is suitable for use with flowmeters which have a NPN output signal. For reliable pulse detection, the pulse amplitude has to go below 1.2V. Signal setting NPN-LP employs a low-pass signal noise filter, which limits the maximum input frequency (read chapter 3).

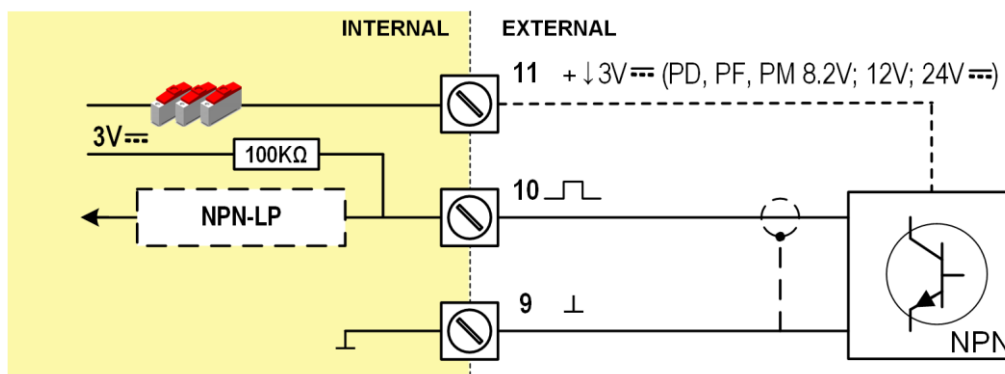

**Fig. 18: Terminal connections - NPN signal input (typical)**

**Pulse-signal PNP / PNP-LP:**

The F126-P is suitable for use with flowmeters which have a PNP output signal. 3V is offered on terminal 11 which has to be switched by the sensor to terminal 10 (SIGNAL). For a reliable pulse detection, the pulse amplitude has to go above 1.2V. Signal setting PNP-LP employs a low-pass signal noise filter, which limits the maximum input frequency (read chapter 3). A sensor supply voltage of 8.2, 12 or 24V DC can be provided with power supply type PD, PF, PM. For a signal detection level of 50% of the supply voltage: please refer to “active signals”.

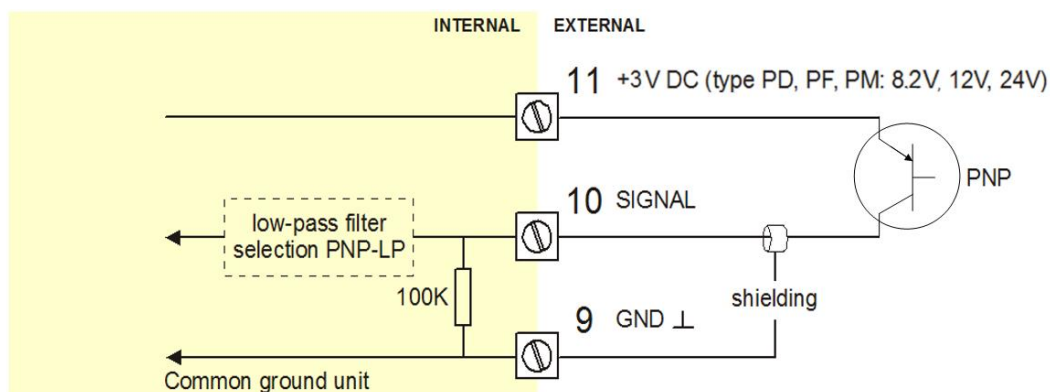

**Fig. 19: Terminal connections - PNP signal input (typical)**

**Active signal 8.2V, 12V and 24V:**

If a sensor gives an active signal (read chapter 3). The detection levels are 50% of the selected supply voltage; approx. 4V (8-1 DC) or 6V (12 DC) or 12V (24 DC). Active signal selection may well be desired in case of power supply type PD, PF, PM is available for sensor supply.

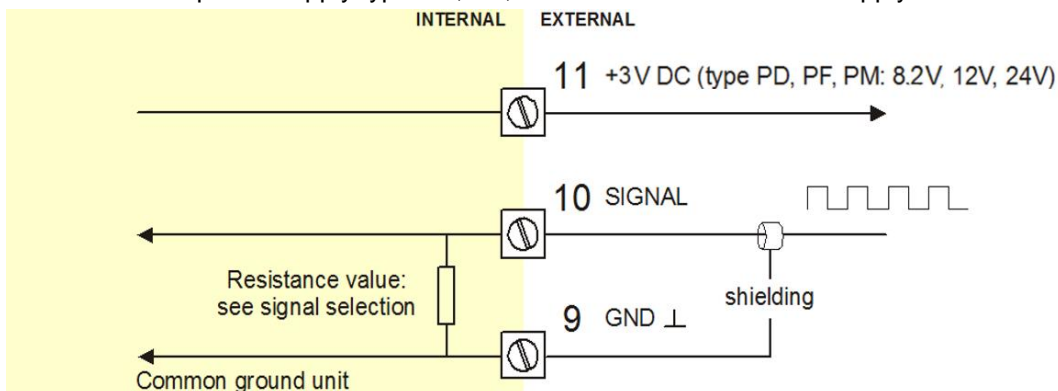

**Fig. 20: Terminal connections - Active signal input (typical)**

**Reed-switch:**

The F126-P is suitable for use with flowmeters which have a reed-switch. To avoid pulse bounce from the reed-switch, it is advised to select REED LP – low-pass filter (read chapter 3).

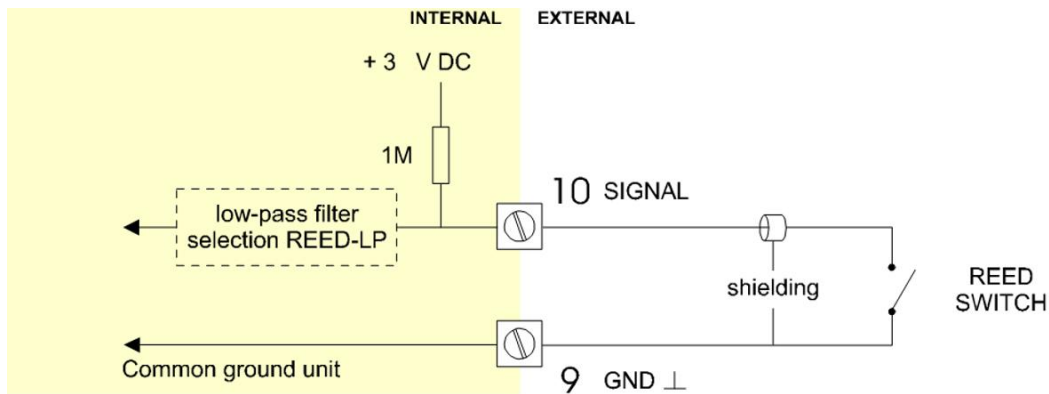

**Fig. 21: Terminal connections - Reed-switch signal input (typical)**

**NAMUR-signal:**

The F126-P is suitable for flowmeters with an Namur signal. The standard F126-P is not able to power the Namur sensor, as an external power supply for the sensor is required. However, a 8.2V sensor supply voltage (terminal 11) can be provided with power supply type PD, PF, PM.

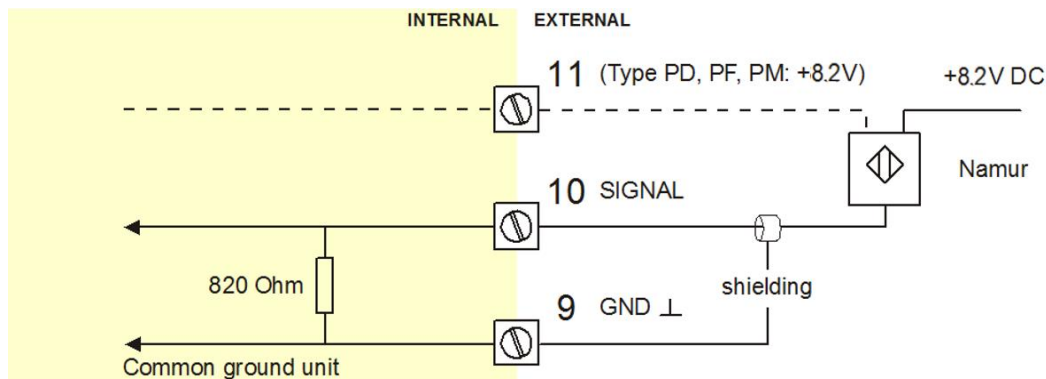

**Fig. 22: Terminal connections - NAMUR signal input (typical)**

**Terminal 20-22; Temperature input TP - PT100:**

The temperature of the inlet flow will be measured with sensor A. Two types of PT100 elements can be connected: 2 or 3-wire. The temp coefficient for the RTD is 0.00385 ohms/ohms/°C. The  $R_0$  is 100 ohms at 0.0°C.

**Terminal 26-31: type CB / CH / CI / CT - communication RS232 / RS485 / TTL (option)**

For connections, refer to figure: Overview of terminal connectors - Standard configuration and options

Full serial communications and computer control in accordance with RS232 (length of cable max. 15 meters) or RS485 (length of cable max. 1200 meters) is possible.

When using the RS232 communication option, terminal 27 is used for supplying the interface.

Please connect the DTR (or the RTS) signal of the interface to this terminal and set it active (+12V).

If no active signal is available it is possible to connect a separate supply between terminals 26 and 27 with a voltage between 8V and 24V.

**Terminal 00 - 01: type ZB backlight (option):**

If the unit is supplied with a power supply:

- type PD, PF or PM, the backlight supply is integrated.
- type PX, use the terminals 00 and 01 to supply the backlight.

The backlight intensity is set in the setup menu: Display.

## 5. INTRINSICALLY SAFE APPLICATIONS

### 5.1. GENERAL INFORMATION AND INSTRUCTIONS



- For the combined connection of the different supply, input and output circuits, the instructions in this manual must be observed. From the safety point of view the circuits shall be considered to be connected to earth
- Certificates, safety values, control drawing and declaration of compliance can be found in the document named: "Fluidwell F1...-XI - Documentation for Intrinsic safety"
- For installation under ATEX directive: this Intrinsically safe device must be installed in accordance with the latest ATEX directive and product certificate KEMA 03ATEX1074 X.
- For installation under IECEx scheme: this Intrinsically safe device must be installed in accordance the product certificate IECEx DEK 11.0042X.
- Exchange of Intrinsically safe battery FWLiBAT-0xx with certificate number KEMA 03ATEX1071 U or IECEx KEM 08.0005U is allowed in Hazardous Area. Read chapter 6 for battery replacement instructions.
- When the enclosure of the F126-P is made of aluminum alloy, when used in a potentially explosive atmosphere requiring apparatus of EPL Ga, the indicator shall be installed so, that even in the event of rare incidents, an ignition source due to impact or friction sparks between the enclosure and iron/steel is excluded.
- When two or more active Intrinsically safe circuits are connected to the indicator, in order to prevent voltage and/or current addition, applicable to the external circuits, precautions must be taken to separate the Intrinsically safe circuits in accordance with EN 60079-11.
- To maintain the degree of protection of at least IP65 in accordance with IEC 60529, suitable cable entries and blanking elements must be used and correctly installed.
- For enclosures and windows with a high surface resistance, potential charging hazard exists. Do not rub these surfaces of the indicator. Clean window and enclosure only with a lint-free cleaning cloth made damp with a mild soap solution.
- Chapter 4 shows general information regarding the electrical installation of your indicator. Chapter 5 gives additional specific information regarding Intrinsically safe installation and overrules the information given in chapter 4.



- Mounting, electrical installation, start-up and maintenance of this device may only be carried out by trained persons authorized by the operator of the facility. Persons must read and understand this manual before carrying out its instructions.
- This device may only be operated by persons who are authorized and trained by the operator of the facility. All instructions in this manual are to be observed.
- Make sure, the measuring system is correctly wired up according to the wiring diagrams. Protection against accidental contact is no longer assured when the housing cover is removed or the panel cabinet has been opened (danger from electrical shock). The housing may only be opened by trained persons authorized by the operator of the facility.
- Take careful notice of the "Safety rules, instructions and precautionary measures" in the front of this manual.



- Special conditions for safe use mentioned in both the certificate and the installation instructions must be observed for the connection of power to both input and / or output circuits.
- When installing this device in hazardous areas, the wiring and installation must comply with the appropriate installation standards for your industry.
- Study the following pages with wiring diagrams per classification.

**Serial number and year of production**

This information can be looked-up in the setup menu: Others.

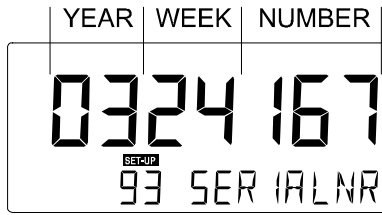

Fig. 23: Example serial number (typical)

**Label information pulse input type – F1xx-...-XI (inside and outside the enclosure)**

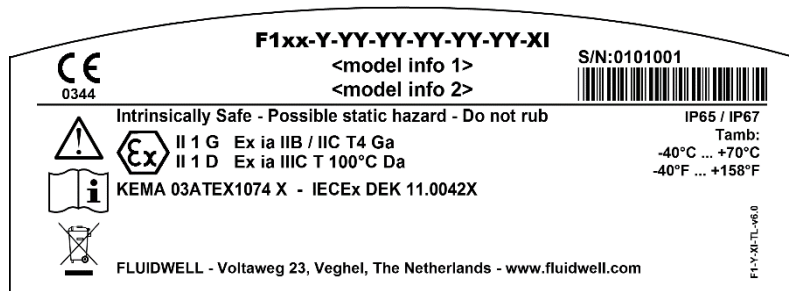

Fig. 24: Label information - Intrinsically safe application (typical)



## 5.2. TERMINAL CONNECTORS INTRINSICALLY SAFE APPLICATIONS



The unit is classified as group IIB/IIIC by default

Note !

Classification of the unit as group IIC is only possible under the following conditions:

The indicator is either supplied by

- the internal supply (option -PC);
- the external supply connected to terminals 0 and 1 (option -PD);
- the circuit supply connected to terminals 7 and 8 (option -AP);
- The maximum values for any of those circuits are those as defined for group IIB/IIIC;
- No other active external Intrinsically safe circuits may be connected to the indicator, with exception of circuits connected to terminals 3 and 4 and/or terminals 5 and 6; the maximum values for any of those circuits are those as defined for group IIB/IIIC.

### Terminal connectors F126-P-EL-TP-XI:

For intrinsically safe applications, consult the safety values in the certificate.

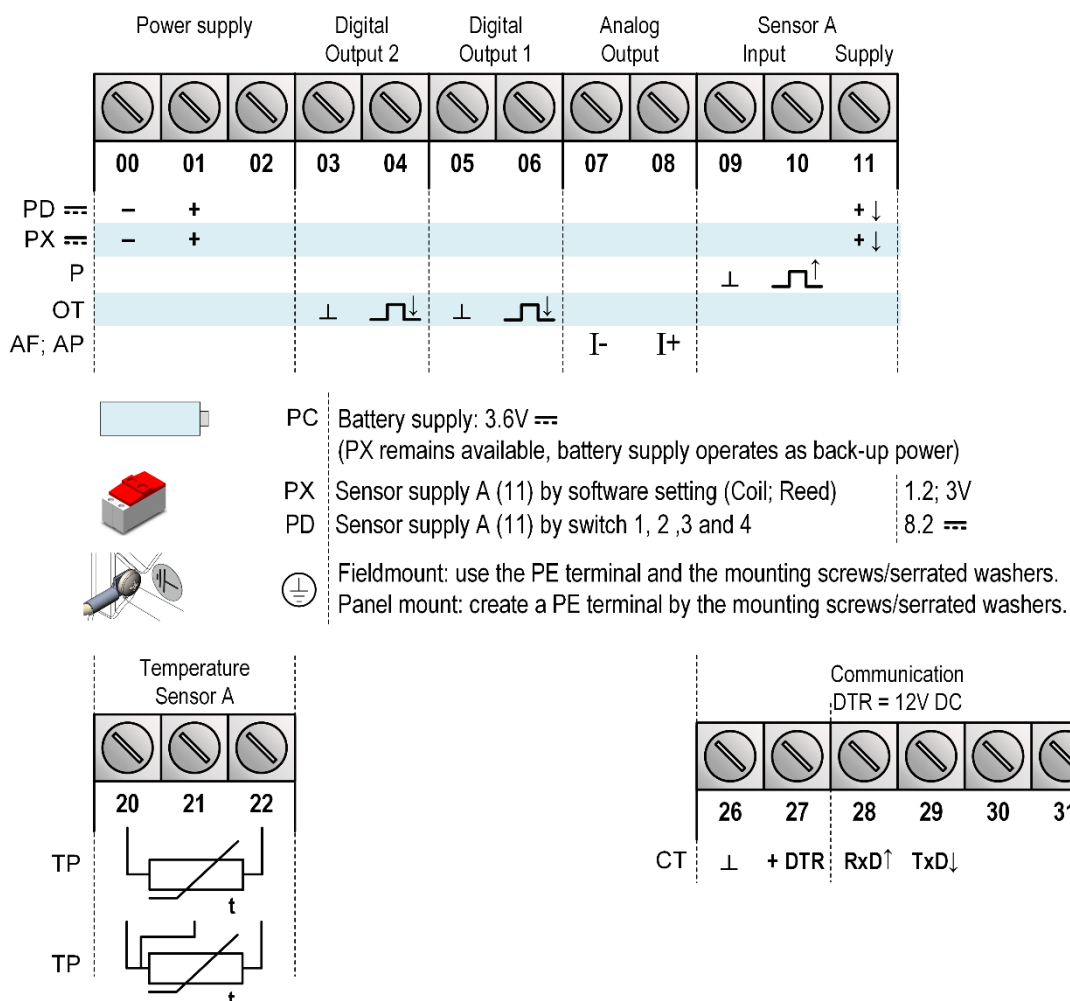

FW-F126-000002-001-EN

Fig. 25: Overview terminal connectors XI – Intrinsically safe applications

**Explanation Intrinsically safe options:**

**Type AF – Intrinsically safe floating 4-20mA analog output:**

A floating 4-20mA signal proportional to the flow rate is available with this option. When the output is disabled, a 3.5mA signal will be generated. Max. driving capacity 1000 Ohm @ 30V DC.

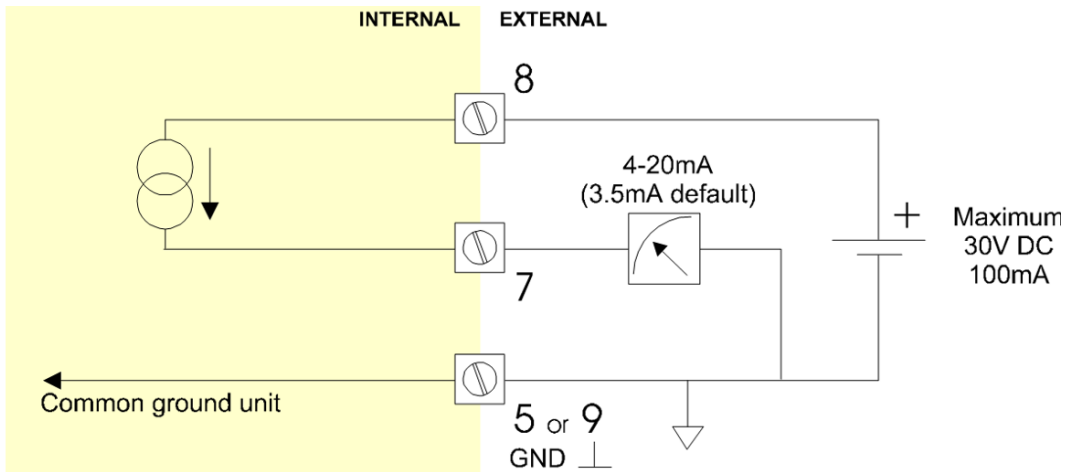

**Fig. 26: Terminal connections - Intrinsically safe floating 4-20mA analog output (typical)**

**For option PD-XI:** It is possible to supply the sensor with different voltages. You can set the voltage with the switches. Internal power is only applicable for low power sensors (Coil, Reed). The sensor supply is set by the firmware: 1.2V DC or 3V DC. External power is only available when the main external power supply is connected. The sensor supply voltage is fixed: 8.2V DC.

**Set the sensor supply**

1. Make the F126-P safe. If applicable, mind the battery power.
2. Open the F126-P and carefully remove the cable-connectors and the protective cover.
3. Find and set the switches and select the  $V_{out}$  as required.
4. Close the protective cover and install the cable connectors.
5. Close the F126-P.



**Risk of electrocution - High voltage!**

Make sure, all the leads to the terminals are disconnected from the F126-P and NEVER connect the mains power supply to the unit when the protection cover has been removed!

Type PD-XI	Power supply in: 16-30V DC / max. 1W				
	Sensor		Sensor supply out		
<p>Switch location (typical)</p>	1	2			
	off	-			Coil 1.2V DC; <1mA Reed 3V DC; <1mA
	on	-			8.2V DC; 7mA (max)
	on	on			

**Fig. 27: Switch position voltage selection option PD-XI**

5.3 CONFIGURATION EXAMPLES

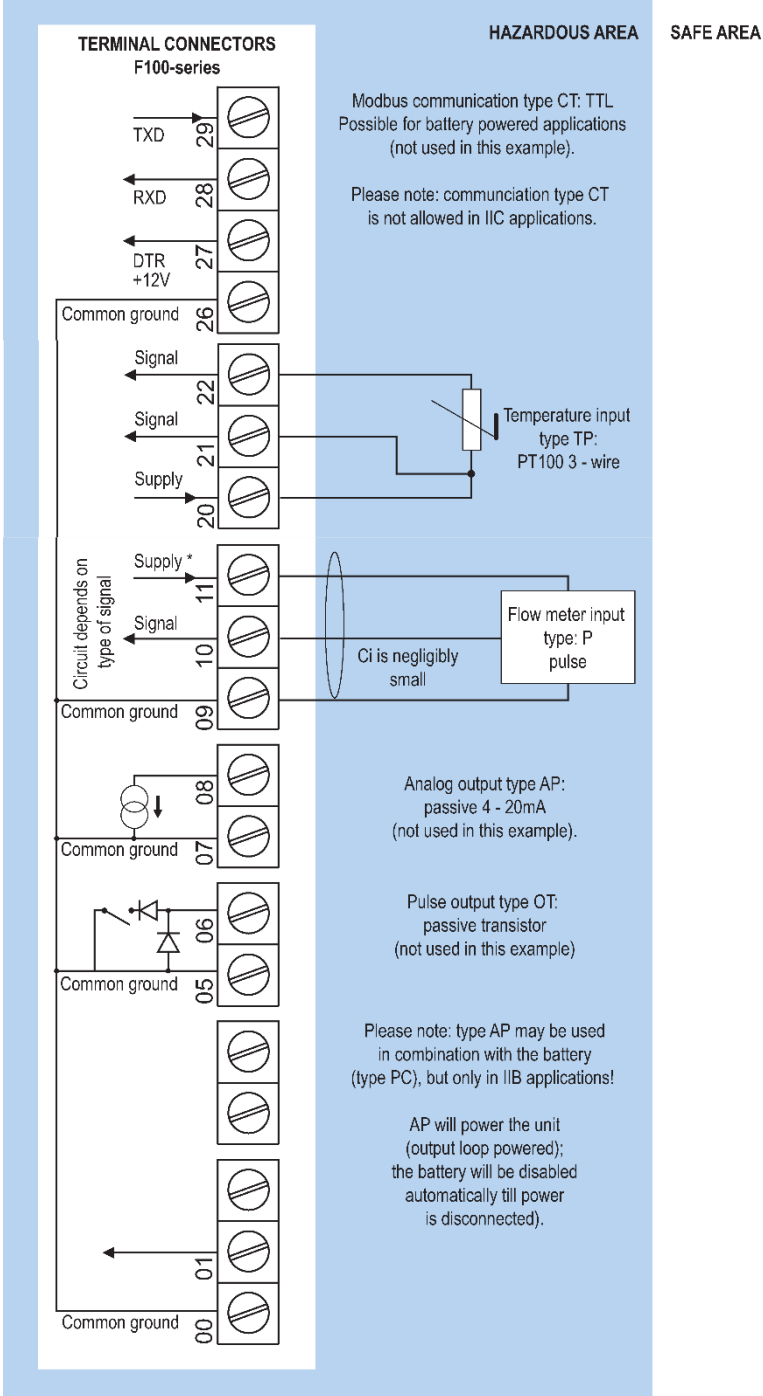

\* Note sensor supply voltage: 1.2V DC for coil sensors or 3.2V DC for other pulse sensors.

Fig. 28: F126-P-(AP)-EL-(OT)-PC-TP-XI - Battery powered - IIB/IIC - IIIC

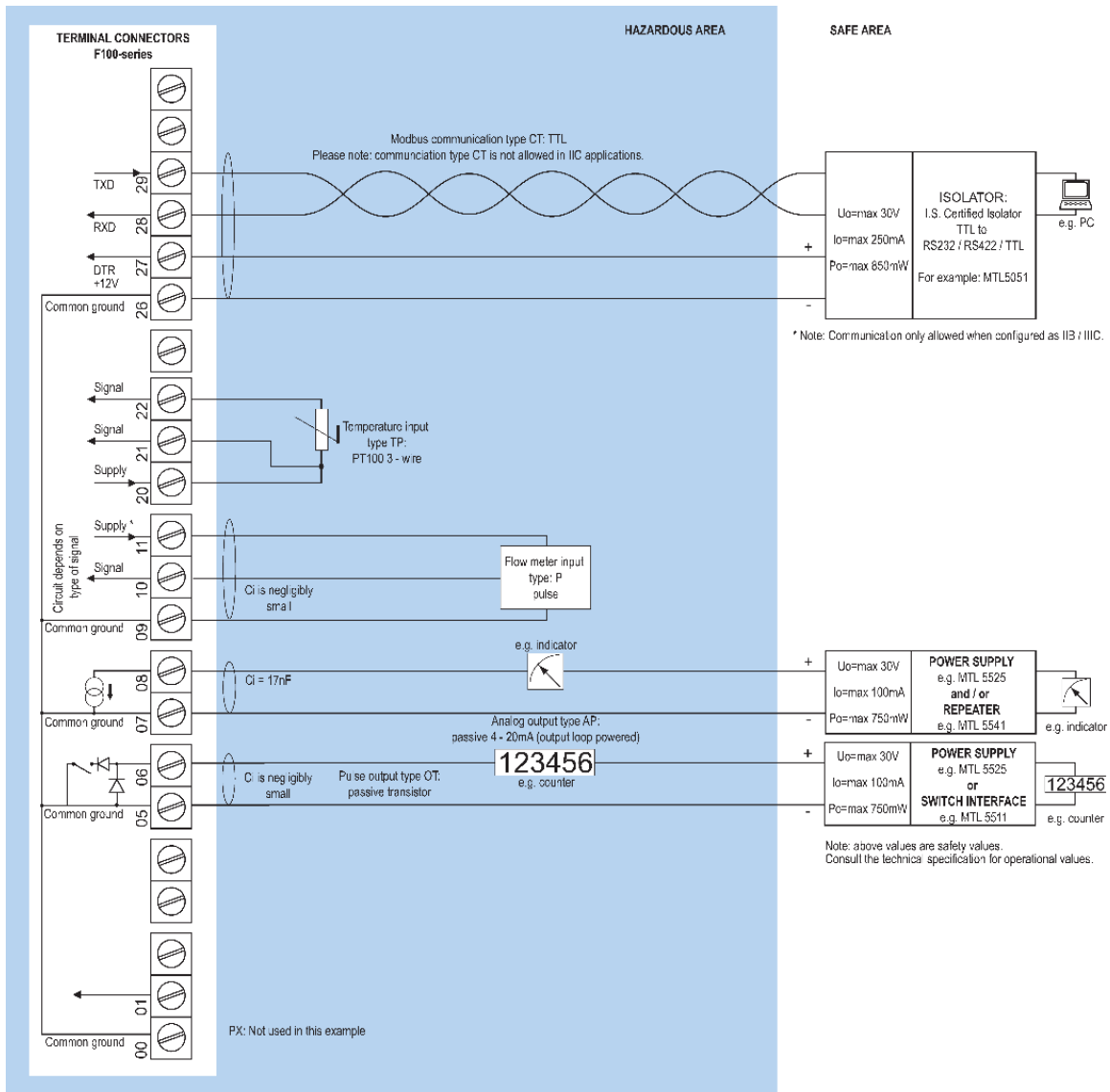

\* Note sensor supply voltage: 1.2V DC for coil sensors or 3.2V DC for other pulse sensors.

**Fig. 29: F126-P-AP-(CT)-EL-OT-(PX)-TP-XI - Output loop powered - IIB/IIC - IIC**

## 5.4 BATTERY REPLACEMENT INSTRUCTIONS

### 5.4.1. SAFETY INSTRUCTIONS



- Handle the battery with care. A mistreated battery can become unsafe. Unsafe batteries can cause (serious) injury to persons.
- Only use batteries which are certified for use in hazardous areas. The use of standard batteries in hazardous area's is not safe and prohibited. Batteries that are regarded as unsafe can cause (serious) injury to persons and damage to the property.
- Mounting, electrical installation, start-up and maintenance of this device may only be carried out by trained persons authorized by the operator of the facility. Persons must read and understand this manual before carrying out its instructions.
- Only use batteries which are certified for use in hazardous areas. The use of standard batteries in hazardous area's is not safe and prohibited. Batteries that are regarded as unsafe can cause (serious) injury to persons and damage to the property.
- For use in hazardous areas we advise to apply FW-LiBAT batteries only.



Caution !

### 5.4.2. REPLACE THE BATTERY (HAZARDOUS AREA)

The batteries are used to store electrical energy. The battery is a high power battery which must be treated carefully. When the battery is mistreated or damaged, there is a risk of a fire, an explosion and serious burns.

1. Mind that you cannot switch off a battery.
2. Make sure, it is safe to work on the battery system.
3. Handle the battery with the utmost care to prevent a short circuit and damage.
4. Do not recharge, crush, disassemble, incinerate, heat above its rated temperature or expose the contents to water.
5. Dispose of the battery in accordance with the (inter)national, the manufacturer's and the plant owner's standards and regulations.
6. Read and understand the instructions.
7. Get approval from the safety officer to do the work.
8. Lock-out/Tag-out the unit and related system.
9. Make sure, it is safe to do the work.

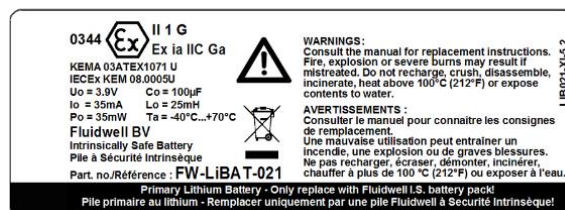
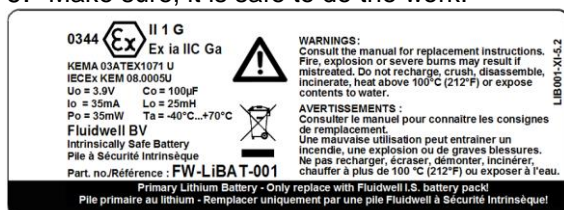

### REMOVE THE BATTERY

1. If necessary, clean the housing with an anti-static cloth made damp with a mild soap solution.
2. Let the enclosure dry onto the air.
3. Carefully, open the enclosure.
4. Keep the removed parts in a clean location.
5. Get access to the battery.
6. Find the battery connector and disconnect the battery from the unit.
7. Remove and keep the battery from the unit.
8. Install an insulation tape over the battery connector to prevent a short circuit.

### INSTALL THE BATTERY

1. Make sure, the new battery is certified for use in the unit.
2. Work as clean as possible, to prevent contamination to enter the unit.
3. Carefully, install the battery.
4. Make sure, the battery is correctly locked into the battery holder.
5. Install the battery connector.
6. Carefully assemble the unit and close the enclosure.
7. With the enclosure carefully closed, do a test of the unit.
8. If necessary, get access to the setup menu and make any adjustments to obtain the correct settings.

### 5.4.3. DISPOSAL OF BATTERIES



- Batteries pose an environmental hazard.
- Do not dispose of as general waste or incinerate.
- Return used batteries to a recycling point.

## 6. MAINTENANCE

### 6.1. GENERAL DIRECTIONS



Caution !

- Mounting, electrical installation, start-up and maintenance of this device may only be carried out by trained persons authorized by the operator of the facility. Persons must read and understand this manual before carrying out its instructions.
- This device may only be operated by persons who are authorized and trained by the operator of the facility. All instructions in this manual are to be observed.
- Make sure, the measuring system is correctly wired up according to the wiring diagrams. Protection against accidental contact is no longer assured when the housing cover is removed or the panel cabinet has been opened (danger from electrical shock). The housing may only be opened by trained persons authorized by the operator of the facility.
- Take careful notice of the "Safety rules, instructions and precautionary measures" in the front of this manual.

The F126-P does not require special maintenance unless it is used in low-temperature applications or surroundings with high humidity (above 90% annual mean). It is the users responsibility to take all precautions to dehumidify the internal atmosphere of the F126-P in such a way that no condensation will occur, e.g. to put a dose of desiccant (drying agent) inside the enclosure just before closing it. Furthermore, it is required to replace the desiccant periodically as advised by its supplier.

#### Battery life-time:

It is influenced by several issues:

- Type of sensor (read chapter 3): NPN and PNP inputs consume more energy than coil inputs;
- Input frequency: the higher the frequency, the shorter the battery life-time;
- Analog output signal; be sure that an external power supply is connected or that the function is disabled if not in use; or else it will have a major influence on the battery life-time;
- Display update: fast display update uses significantly more power;
- Pulse output and communications;
- Low temperatures; the available power will be less due to battery chemistry.



Note !

*It is strongly advised to disable the unused functions.*

#### Check periodically:





- The condition of the enclosure, cable glands and front panel.
- The input/output wiring for reliability and aging symptoms.
- The process accuracy. As a result of wear and tear, re-calibration of the flowmeter and temperature sensor might be necessary. Do not forget to re-enter any subsequent K-Factor or Span alterations.
- The indication for low-battery.
- Clean window and enclosure only with a lint-free cleaning cloth made damp with a mild soap solution.. Do not use any aggressive solvents as these might damage the coating.



### 6.2 REPAIR

This product cannot be repaired by the user and must be replaced with an equivalent certified product. Repairs should only be carried out by the manufacturer or his authorized agent.

## APPENDIX A. TECHNICAL SPECIFICATIONS

General	
<b>Display</b>	
Type	High intensity reflective numeric and alphanumeric LCD, UV-resistant.
Digits	Seven 17mm (0.67") and eleven 8mm (0.31"). Various symbols and measuring units.
Refresh rate	User definable: 8 times/sec – 30 secs.
Type ZB	LCD with LED backlight. Improved readability in full sunlight and darkness. Power requirements: 12-24V DC + 10% or type PD, PF, PM. Power consumption max. 1 Watt.
<b>Enclosures</b>	
General	Die-cast aluminum or GRP (Glassfibre Reinforced Polyamide) enclosure with Polycarbonate window, silicone gaskets. UV stabilized and flame retardant material.
Control Keys	Three industrial micro-switch keys. UV-stabilized silicone keypad.
Painting	Aluminum enclosure only: UV-resistant 2-component industrial painting.
Panel-mount enclosures	Dimensions : 130 x 120 x 60mm (5.10 » x 4.72 » x 2.38 ») – LxHxD.
Classification	IP65 / TYPE 4(X)
Panel cut-out	115 x 98mm (4.53" x 3.86") LxH.
Type HC	GRP panel-mount enclosure
Type HB	Aluminum panel-mount enclosure
Field/wall-mount enclosures	Dimensions : 130 x 120 x 75mm (5.10" x 4.72" x 2.95") – LxHxD.
Classification	IP67 / TYPE 4(X)
Aluminium enclosures	
Type HA	Drilling: 2x PG9 – 1x M20.
Type HL	Drilling: 2x ½"NPT.
Type HM	Drilling: 2x M16 – 1x M20.
Type HN	Drilling: 1x M20.
Type HO	Drilling: 2x M20.
Type HP	Drilling: 6x M12.
Type HT	Drilling: 1x ½"NPT.
Type HU	Drilling: 3x ½"NPT.
Type HV	Drilling: 4x M20
Type HZ	No drilling.
GRP enclosures	
Type HD	No drilling.
Type HE	Drilling: 2x 16mm (0.63") – 1x 20mm (0.78").
Type HF	Drilling: 1x 22mm (0.87").
Type HG	Drilling: 2x 20mm (0.78").
Type HJ	Drilling: 3x 22mm (0.87").
Type HH	Drilling: 6x 12mm (0.47").
Type HK	Flat bottom – no drilling.
<b>Ambient temperatures</b>	
Operational	-40°C to +80°C (-40°F to +176°F)
Intrinsically safe	-40°C to +70°C (-40°F to +158°F)
Relative humidity	90%, no condensation allowed.
<b>Power supply</b>	
Type AP	8-30V DC; Power consumption max. 0.5 Watt.
Type PB	Lithium battery - life-time depends upon settings - up to 5 years.
Type PC	Intrinsically safe lithium battery - life-time depends upon settings - up to 5 years.
Type PD	8-24V AC / 8-30V DC; Power consumption max. 5 Watt.
Type PD-ZB	10-24V AC / 12-30V DC; Power consumption max. 5 Watt.
Type PD-XI	16-30V DC; Power consumption max. 1 Watt.
Type PF	15-24V AC / 20-30V DC; Power consumption max. 15 Watt.
Type PM	115-230V AC; Power consumption max. 15 Watt.
Type PX	8-30V DC; Power consumption max. 0.75 Watt.
Type PX-ZB	12-30V DC; Power consumption max. 1.5 Watt.
Type PX-XI	8-30V DC; Power consumption max. 0.75 Watt.
Note I.S. applications	<b>For Intrinsically safe applications, consult the safety values in the certificate.</b>

Sensor excitation					
Type PB / PC / PX	3V DC for low power pulse signals and 1.2V DC for coil pick-up.				
Type PD	1.2; 3; 8.2; 12; 24V DC - max. 50mA@24V DC				
Type PD-XI	Intrinsically safe: Pulse signals: 1.2; 3; 8.2 - max. 7mA@8.2V DC.				
Type PF / PM	1.2; 3; 8.2; 12; 24V DC - max. 400mA@24V DC.				
Terminal connections					
Type:	Removable plug-in terminal strip. Wire max. 1.5m <sup>2</sup> and 2.5m <sup>2</sup>				
Data protection					
Type	EEPROM backup of all setting. Backup of running totals every minute. Data retention at least 10 years.				
Password	Configuration settings can be password protected.				
Hazardous area					
Intrinsically safe Type XI	<table border="1"> <tr> <td><b>ATEX approval :</b></td> <td><b>IECEx approval :</b></td> </tr> <tr> <td>  II 1 G Ex ia IIB/IIC T4 Ga II 1 D Ex ia IIIC T100°C Da </td> <td>           Ex ia IIB/IIC T4 Ga Ex ia IIIC T100°C Da </td> </tr> </table>	<b>ATEX approval :</b>	<b>IECEx approval :</b>	 II 1 G Ex ia IIB/IIC T4 Ga II 1 D Ex ia IIIC T100°C Da	Ex ia IIB/IIC T4 Ga Ex ia IIIC T100°C Da
<b>ATEX approval :</b>	<b>IECEx approval :</b>				
 II 1 G Ex ia IIB/IIC T4 Ga II 1 D Ex ia IIIC T100°C Da	Ex ia IIB/IIC T4 Ga Ex ia IIIC T100°C Da				
Explosion proof Type XD/XF	ATEX approval ref:  II 2 EEx d IIB T5. Weight appr. 15kg. Dimensions of enclosure: 350 x 250 x 200mm (13.7" x 9.9" x 7.9") LxHxD.				
Directives and Standards					
EMC	EN 61326-1; FCC 47 CFR part 15				
LVD	EN/IEC 61010-1				
ATEX / IECEx	EN/IEC 60079-0; EN/IEC 60079-11				
RoHS	EN 50581				
IP & NEMA	EN 60529; NEMA 250				

Inputs	
Flowmeter	
Type P	nnp; npn-lp; reed; reed-lp; pnp; pnp-lp; namur; coil-hi; coil-lo; 8-1 DC; 12 DC; 24 DC
Frequency	Minimum 0 Hz – maximum 7 kHz for total and flow rate. Maximum frequency depends on signal type and internal low-pass filter. E.g. Reed switch with low-pass filter: max. frequency 120 Hz.
K-Factor	0.000010 - 9999999 with variable decimal position.
Low-pass filter	nnp-lp; reed-lp; pnp-lp
Temperature	
Type TP	2 or 3 wire PT100.
Standard range	-100°C to +200°C (-148°F to 392°F) – accuracy 0.1 °C (0.18°F).
Extended range (ZV)	-200°C to +800°C (-328°F to 1832°F) - accuracy 0.5 °C (0.9°F).
Update time	four times a second.
 Note !	The linearity is internally compensated.
Type TA	(0)4-20mA - with signal calibration feature at any current within the range.
Type TU	0-10 V - with signal calibration feature at any voltage within the range.
Accuracy	Resolution: 14 bit.. Error < 0.025mA / ±0.125% FS. Low level cut-off programmable.
Span	0.000010 - 9999999 with variable decimal position.
Update time	Four times a second.
Voltage drop (TA only)	2.5 Volt
Load impedance	3kOhm
 Note !	Type TA and TU: external power to sensor required; e.g. type PD.



<b>Outputs</b>	
<b>Analog output</b>	
Function	transmitting compensated flow rate.
Accuracy	10 bit. Error < 0.05% - update 10 times a second. Software function to calibrate the 4.00mA and 20.00mA levels precisely within set-up.
Load	max. 1 kOhm
Type AA	Active 4-20mA output (requires type OA + PD, PF or PM).
Type AB	Active 0-20mA output (requires type OA + PD, PF or PM).
Type AF	Passive floating 4-20mA output for Intrinsically safe applications (requires type PC or PD).
Type AI	Passive galvanic isolated output (requires type PB, PD, PF, PL or PM).
Type AP	Passive 4-20mA output - output loop powered.
Type AU	Active 0-10V output (requires type OA + PD, PF or PM).
<b>Switch output(s)</b>	
Function	One pulse output - transmitting accumulated total.
Pulse output	Max. frequency 500Hz. Pulse length user definable between 0.001 up to 9.999 seconds.
Type OA	Active 24V DC transistor output; max. 50mA per output (requires type AA + PD, PF or PM).
Type OR	Isolated mechanic relay output; max. switch power 230V AC - 0,5A (requires type PF or PM).
Type OT	Passive transistor output - not isolated. Load max. 50V DC - 300mA.
<b>Communication option</b>	
Protocol	bus-rtu; bus-asc
Speed	1200; 2400; 4800; 9600
Addressing	1 - 247
Type CB	RS232
Type CH	RS485 2-wire
Type CI	RS485 4-wire
Type CT	TTL Intrinsically safe communication.
Type CX	no communication.
<b>Operational</b>	
<b>Operator functions</b>	
Shown functions	<ul style="list-style-type: none"> <li>• compensated total and/or compensated flow rate.</li> <li>• compensated total and compensated accumulated total.</li> <li>• line temperature.</li> <li>• compensated total can be reset to zero by pressing the CLEAR-key twice.</li> </ul>
<b>Total</b>	
Digits	7 digits.
Units	L; m <sup>3</sup> ; kg; lb; GAL; USGAL; bbl; no unit
Decimals	000000; 111111.1; 22222.22; 3333.333
Note	total can be reset to zero.
<b>Accumulated total</b>	
Digits	11 digits.
Units / decimals	according to selection for total.
<b>Flow rate</b>	
Digits	7 digits.
Units	mL; L; m <sup>3</sup> ; mg; g; kg; ton; gal; bbl; lb; cf; rev; - - - (no unit); scf; nm <sup>3</sup> ; nL; p
Decimals	000000; 111111.1; 22222.22; 3333.333
Time units	/sec; /min; /hour; /day
<b>Line temperature</b>	
Digits	7 digits.
Units	°C; °F; K
Decimals	1
Normal temperature	default: 273.15 K - any temperature can be set.
<b>Flow equations</b>	
Type EL	Equations Liquid - flow computer for corrected liquid volume
Formula	$Q_{normal} = Q * (1 + \alpha * (T_{normal} - T))$ where $\alpha$ = thermal expansion coefficient.

## APPENDIX B. PROBLEM SOLVING

In this appendix, several problems are included that can occur when the F126-P-EL-TP is going to be installed or while it is in operation.

### Flowmeter does not generate pulses:

Check:

- Signal selection;
- Pulse amplitude;
- Flowmeter, wiring and connection of terminal connectors;
- Power supply of flowmeter.

### Flowmeter generates "too many pulses":

Check:

- Settings for total and Flow rate;
- Type of signal selected with actual signal generated;
- Sensitivity of coil input;
- Proper grounding of the F126-P;
- Use screened wire for flowmeter signals and connect screen to terminal 9. (unless connected at sensor).

### Analog output does not function properly:

Check:

- is the analog output enabled?
- are the flow-levels programmed correctly?
- connection of the external power-supply according to the specification.

### Pulse output does not function:

Check:

- amount: pulse per "x" quantity; is the value programmed reasonable and will the maximum output be under 20Hz?
- width; is the external device able to recognize the selected pulse width and frequency?

### Flow rate displays "0 / zero" while there is flow (total is counting):

Check:

- are the K-Factor and time unit correct?
- The unit has to count the number of pulses according to setup 26 within the time according to setup 27. Make sure, setup 27 is set to 10.0 seconds for example : the result is that the unit has at least 10 seconds time to measure the number of pulses according to setup 26.

### The password is unknown:

- If the password is not 1234, there is only one possibility left: call your supplier.

## ALARM

When the alarm flag starts to blink an internal alarm condition has occurred. Press the "select button" several times to display the error code. When multiple errors arise at the same time, their error codes are added and their sum is shown. The digital [d] codes are:

### Not recoverable by the end user:

- [d] 0 = no error
- [d] 1 = display error
- [d] 2 = data-storage error
- [d] 3 = error 1 + error 2 simultaneously
- [d] 4 = initialization error
- [d] 16 = PT100 ADC error

### Recoverable by the end user:

- [d] 32 = Correction calculation factor error
- [d] 64 = TPC calculation error
- [d] 128 = PT100 sensor out of range error

For a not recoverable error, keep the error code at hand and contact your supplier.

## APPENDIX C. COMMUNICATION VARIABLES

### General

The product is fitted with the Modbus communication protocol and can be equipped with various physical interfaces like RS485 and RS232 (please see device datasheet for available options). The tables below show the various variables that can be accessed through the communication. Currently, the function codes supported are:

- function code 3 "Read Holding Registers" (4x references);
- function code 16 "Preset Multiple Registers" (4x references).

The table below shows the Modbus PDU addresses in a decimal format, followed by its hexadecimal representation (0x0000). When the PLC address range is required (4x references are typically used by PLCs), please add a value of 40001 to the Modbus PDU address. E.g. reading the serial number of the product with PLC-based addressing means: 165 + 40001 = register 40166.

**The variables that consist of a multiple register must always read/write in 1 single action!**

Refer to the illustration:

For this example it is assumed that the variable accumulated total has 3 registers (words) with address 566, 567 and 568. When a transmission is done, register 566, which acts as the MSW, arrives first with bit 15 which is the MSB of the lowest addressed word, but is also the MSB (bit 47) of the complete variable that represents the Accumulated total.

Although most Modbus Masters will support variables that span 2 registers, variables spanning more registers sometimes require you to manually calculate the resulting value.

MSW			ACCUMULATED TOTAL			LSW		
REGISTER 566	[d] 00001 [h] 0001		REGISTER 567	[d] 45236 [h] b0b4		REGISTER 568	[d] 34756 [h] 87c4	
15			0	15		0	15	
MSB						LSB		
47			32	31		16	15	

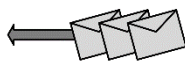

**ACCUMULATED TOTAL:** [register 566 \* 4294967296] + [register 567\* 65536] + [register 568\*1] =  
[d] **ACCUMULATED TOTAL:** [00001 \* 4294967296] + [45236 \* 65536] + [34756\*1] = 7259588540  
[h] **ACCUMULATED TOTAL:** 0x[0001] [b0b4] [87c4] = 1B0B487BC

FW-F000-000032-002#AL

For additional information regarding using your Modbus device, please read our 'General Modbus Communication Protocol' and 'Modbus troubleshooting guide' that are available through our website or your distributor.

### Runtime variables

PDU ADDRESS	REGISTER	VARIABLE RUN TIME	NO. REGISTERS	R/W	TYPE	VALUE / REMARKS
[d] 572 [h] 0x23C	40573	flow rate	2	r	uint32	0...9999999; Representation: unit, time, decimals depending on variables 48, 49, 50
[d] 566 [h] 0x236	40567	total	3	r	uint48	0...99999999999; Representation: unit, decimals depending on variables 32, 33
[d] 560 [h] 0x230	40561	accumulated total	3	r	uint48	0...999999999999999; Representation: unit, decimals depending on variables 32, 33
[d] 516 [h] 0x204	40517	error status (bitfield)	1	r	uint16	[d] 0 = no error [d] 1 = display error [d] 2 = data-storage error [d] 3 = error 1 + error 2 simultaneously [d] 4 = initialization error [d] 16 = PT100 ADC error [d] 32 = Correction calculation factor error [d] 64 = TPC calculation error [d] 128 = PT100 sensor out of range error

#### **Reading flow rate, total or accumulated total:**

The returned values are given including the decimals and represent the actual value. The given value may differ from the value that is shown on the display – this is due to the fact that the display is limited in the number of digits and may have a slower update rate set.

For example when two decimals are selected for total and total has a value of 123456,78 the display will show 23456,78 while communication will read a "total" of 12345678 and a "total decimals" of 2.

#### **\* Clearing total:**

It is possible to clear the total counter by means of writing a value of 0 to all the 3 registers of total/flow rate in a single write action. Writing any other value will result in the reply of an error message because the registers of total/flow rate are during operation read-only.

## Setup variables

PDU ADDRESS	REGISTER	VARIABLE TOTAL	NO. REGISTERS	R/W	TYPE	VALUE / REMARKS
[d] 32 [h] 0x020	40033	unit	1	r/w	uint16	0=none      3=kg      6= USGAL 1=L          4= lb      7= bbl 2= m <sup>3</sup> 5=GAL
[d] 33 [h] 0x021	40034	decimals	1	r/w	uint16	0...3
[d] 34 [h] 0x022	40035	K-Factor	2	r/w	uint32	1...9999999 Representation: 0.000010...9999999 depending on variable 54: decimals K-Factor.
[d] 37 [h] 0x025	40038	decimals K-Factor	1	r/w	uint16	0...6

PDU ADDRESS	REGISTER	VARIABLE FLOW RATE A	NO. REGISTERS	R/W	TYPE	VALUE / REMARKS
[d] 48 [h] 0x030	40049	unit	1	r/w	uint16	0=mL      4=g      8=bbl      12=none 1=L          5=kg      9=lb      13=scf 2= M <sup>3</sup> 6=ton      10=cf      14=NM <sup>3</sup> 3=mg      7=GAL      11=rev      15=NL 16=P
[d] 49 [h] 0x031	40050	time unit	1	r/w	uint16	0=/sec      1=/min      2=/hour      3=/day
[d] 50 [h] 0x032	40051	decimals	1	r/w	uint16	0...3
[d] 51 [h] 0x033	40052	K-Factor	2	r/w	uint32	1...9999999 Representation: 0.000010...9999999 depending on variable 54: decimals K-Factor.
[d] 54 [h] 0x036	40055	decimals K-Factor	1	r/w	uint16	0...6
[d] 62 [h] 0x03E	40063	filter	1	r/w	uint16	1...99
[d] 71 [h] 0x047	40072	period	1	r/w	uint16	1...999 Representation: 0.1 – 99.9 sec

PDU ADDRESS	REGISTER	VARIABLE DISPLAY	NO. REGISTERS	R/W	TYPE	VALUE / REMARKS
[d] 64 [h] 0x040	40065	function	1	r/w	uint16	0: total      1: flow rate
[d] 67 [h] 0x043	40068	backlight brightness	1	r/w	uint16	0: off      2: 40%      4: 80% 1: 20%      3: 60%      5: 100%

PDU ADDRESS	REGISTER	VARIABLE POWER MANAGEMENT	NO. REGISTERS	R/W	TYPE	VALUE / REMARKS
[d] 80 [h] 0x050	40081	LCD update time	1	r/w	uint16	0=fast      2=3sec      4=30sec 1=1sec      3=15sec      5=off
[d] 81 [h] 0x051	40082	power mode	1	r/w	uint16	0=operational      1=shelf

PDU ADDRESS	REGISTER	VARIABLE FLOWMETER	NO. REGISTERS	R/W	TYPE	VALUE / REMARKS
[d] 96 [h] 0x060	40097	flowmeter signal	1	r/w	uint16	0: npn      4: pnp      8: coil-lo 1: npn lp      5: pnp lp      9: act. 8.2V 2: reed      6: namur      10: act. 12V 3: reed lp      7: coil-hi      11: act. 24V

PDU ADDRESS	REGISTER	VARIABLE TEMPERATURE	NO. REGISTERS	R/W	TYPE	VALUE / REMARKS
[d] 209 [h] 0x0D1	40210	display	1	r/w	uint16	0: °C      1: °F      2: K
[d] 208 [h] 0x0D0	40209	number of wires	1	r/w	uint16	0: 2      1: 3
[d] 199 [h] 0x0C7	40200	filter	1	r/w	uint16	1...99
PDU ADDRESS	REGISTER	VARIABLE FORMULA	NO. REGISTERS	R/W	TYPE	VALUE / REMARKS
[d] 74 [h] 0x04A	40075	thermal expansion coefficient	1	r/w	uint32	0...9999999 (*10 <sup>-9</sup> )
[d] 537 [h] 0x219	40538	normal temperature	1	r/w	uint32	0.00...9999999; step: 0.01; Representation: temperature unit depending on variable 209
PDU ADDRESS	REGISTER	VARIABLE ANALOG OUTPUT	NO. REGISTERS	R/W	TYPE	VALUE / REMARKS
[d] 112 [h] 0x070	40113	analog output	1	r/w	uint16	0: disable      1: enable
[d] 113 [h] 0x071	40114	rate-min	2	r/w	uint32	0...9999999 Representation: unit, time, decimals depending on variables 48, 49, 50
[d] 116 [h] 0x074	40017	rate-max	2	r/w	uint32	0...9999999 Representation: unit, time, decimals depending on variables 48, 49, 50
[d] 119 [h] 0x077	40120	cut off	1	r/w	uint16	0...99 Representation: 0.0 – 9.9%
[d] 120 [h] 0x078	40121	tune-min	1	r/w	uint16	0...9999
[d] 122 [h] 0x07A	40023	tune-max	1	r/w	uint16	0...9999
[d] 99 [h] 0x063	40100	filter	1	r/w	uint16	0...99
PDU ADDRESS	REGISTER	VARIABLE PULSE OUTPUT	NO. REGISTERS	R/W	TYPE	VALUE / REMARKS
[d] 128 [h] 0x080	40129	pulse width	1	r/w	uint16	0...9999, (0=disabled) Representation: 0.000 – 9.999 sec
[d] 133 [h] 0x085	40134	decimals	1	r/w	uint16	0...3
[d] 130 [h] 0x082	40131	amount	2	r/w	uint32	1...9999999 Representation: 0.001 – 9999999 depending on variable 133
PDU ADDRESS	REGISTER	VARIABLE COMMUNICATION	NO. REGISTERS	R/W	TYPE	VALUE / REMARKS
[d] 144 [h] 0x090	40145	speed (baud rate)	1	r/w	uint16	0: 1200      2: 4800 1: 2400      3: 9600
[d] 145 [h] 0x091	40146	Modbus address	1	r/w	uint16	1...247
[d] 146 [h] 0x092	40147	Modbus mode	1	r/w	uint16	0: ASCII      1: RTU      2: OFF

PDU ADDRESS	REGISTER	VARIABLE OTHERS	NO. REGISTERS	R/W	TYPE	VALUE / REMARKS
[d] 173 [h] 0x0AD	40174	model number	1	r	uint16	0...9999
[d] 160 [h] 0x0A0	40161	model suffix	1	r	char	Representation: ASCII character
[d] 162 [h] 0x0A2	40163	firmware version	2	r	uint32	0...999999 Representation: xx.xx.xx
[d] 165 [h] 0x0A5	40166	serial no	2	r	uint32	0...9999999
[d] 168 [h] 0x0A8	40169	password	1	r	uint16	0...9999
[d] 170 [h] 0x0AA	40171	tag-nr	2	r/w	uint32	0...9999999

## APPENDIX D. DECLARATION OF CONFORMITY



### Declaration of Conformity

#### Fluidwell F1-series indicators

Veghel, July 2016

We, Fluidwell BV, declare under our sole responsibility that the F1-series indicators are designed and will operate conform the following applicable European Directives and Harmonised Standards, when installed and operated according to the related manual:

<b>EMC Directive</b>		EN61000-6-2:2005; EN61000-6-3:2007; EN61326-1:2013
<b>RoHS Directive</b>		EN 50581:2012
<b>Low Voltage Directive</b>	For options –PM or –OR:	EN61010-1:2010
<b>ATEX Directive</b>	For option –XI, intrinsically safe:	EN60079-0:2012+A11; EN60079-11:2012
	Protective system:	Ⓜ II 1 G Ex ia IIB/IIC T4 Ga Ⓜ II 1 D Ex ia IIIC T100 °C Da
<b>Certification</b>	Certificates:	KEMA 03ATEX1074 X, Issue 5
	Notified body 0344:	DEKRA Certification BV, Meander 1051, 6825 MJ, Arnhem, the Netherlands.

Last two digits of the year in which the CE marking was affixed: 03.

Fluidwell BV

I. Meij, Manager Technology

Fluidwell BV are ISO9001 certified by DEKRA Certification BV, Meander 1051, 6825 MJ, Arnhem, The Netherlands.

	<b>Fluidwell bv</b> P.O. Box 6 • 5460 AA • Veghel Voltaweg 23 • 5466 AZ • Veghel The Netherlands	Telephone: +31 (0) 413 - 343 786 Telefax: +31 (0) 413 - 363 443 Email: displays@fluidwell.com Internet: www.fluidwell.com	Trade Reg. No: 17120985 VAT No: NL8085.29.699.B.01 Bank: ING-Bank SWIFT Nr / BIC: INGBNL2A	EUR account no: 66.63.96.078 IBAN: NL73 INGB 0666 3960 78 USD account no: 02.20.81.771 IBAN: NL22 INGB 0022 0817 71

## INDEX OF THIS MANUAL

accumulated Total	8	Intrinsically Safe options	34
actual settings	51	IP classification	18
analog		Low-battery alarm	8
floating output.	34	maintenance	38
flowrate min.	15	model	17
intrinsically safe output.	34	NAMUR-signal	30
tune / calibrate	15	operational	7, 9, 10, 18, 38
Analog output	26	operator level	8
backlight		pass code	17
density	13	power supply	26
battery life time	38	Problem solving	42
Clear Total	8	pulse output	
coil-signal	28	pulse length / period time	16
Coil-signal	28	pulse per quantity	16
communication	30	Pulse output	25
family-specific variables	43, 47	Pulse-signal NPN/PNP	29
contents	5	rate/Total	8
Dimension enclosures	19	Reed-switch:	30
display		serial number	17
function	13	tagnumber	17
filter	14	Technical specification	39
Flowmeter input	28	temperature - normal	15
flowrate		temperature input	30
calculation	13	temperature settings	14
Installation	18	time/date	8
Intrinsic safety	31, 33	version software	17



## LIST OF FIGURES IN THIS MANUAL

Fig. 1: typical application .....	6
Fig. 2: Control Panel.....	7
Fig. 3: Process information (typical) .....	8
Fig. 4: Low-battery alarm (typical) .....	8
Fig. 5: Aluminum enclosures - Dimensions .....	19
Fig. 6: GRP enclosures - Dimensions .....	20
Fig. 7: Overview of terminal connectors - Standard configuration and options .....	24
Fig. 8: Sensor supply voltage - Switch setting .....	25
Fig. 9: Terminal connections - Active output (typical) .....	26
Fig. 10: Terminal connections - Mechanical relay output (typical) .....	26
Fig. 11: Terminal connections - Pulse output (typical) .....	26
Fig. 12: Terminal connections - 4-20mA analog output (typical).....	27
Fig. 13: Terminal connections - Active 0-20mA analog output (typical).....	27
Fig. 14: Terminal connections - Isolated 4-20mA analog output (typical).....	27
Fig. 15: Terminal connections - Passive 4-20mA analog output (typical).....	28
Fig. 16: Terminal connections - Active 0-10V analog output (typical).....	28
Fig. 17: Terminal connections - Coil signal input (typical).....	28
Fig. 18: Terminal connections - NPN signal input (typical) .....	29
Fig. 19: Terminal connections - PNP signal input (typical) .....	29
Fig. 20: Terminal connections - Active signal input (typical) .....	29
Fig. 21: Terminal connections - Reed-switch signal input (typical).....	30
Fig. 22: Terminal connections - NAMUR signal input (typical).....	30
Fig. 23: Example serial number (typical).....	32
Fig. 24: Label information - Intrinsically safe application (typical).....	32
Fig. 25: Overview terminal connectors XI – Intrinsically safe applications .....	33
Fig. 26: Terminal connections - Intrinsically safe floating 4-20mA analog output (typical) .....	34
Fig. 27: Switch position voltage selection option PD-XI.....	34
Fig. 28: F126-P-(AP)-EL-(OT)-PC-TP-XI - Battery powered - IIB/IIC - IIIC .....	35
Fig. 29: F126-P-AP-(CT)-EL-OT-(PX)-TP-XI - Output loop powered - IIB/IIC - IIIC .....	36



LIST OF CONFIGURATION SETTINGS			
SETTING	DEFAULT	DATE :	DATE :
<b>1 - TOTAL</b>	Enter your settings here		
11 unit	L		
12 decimals	0000000		
13 K-Factor	0000001		
14 decimals K-Factor	0		
<b>2 - FLOW RATE</b>			
21 unit	L		
22 time unit	/min		
23 decimals	0000000		
24 K-Factor	0000001		
25 decimals K-Factor	0		
26 filter	1		
27 period	1.0 sec.		
<b>3 - DISPLAY</b>			
31 function	total		
32 light	100%		
<b>4 - POWER MANAGEMENT</b>			
41 LCD-new	1 sec.		
42 battery mode	operational		
<b>5 - FLOWMETER</b>			
51 signal	coil-lo		
<b>6 - TEMPERATURE</b>			
61 display	°C		
62 no. of wires	2		
63 filter	1		
<b>7 - FORMULA</b>			
71 equations type	EL		
72 thermal exp. coefficient	0.000000		
73 normal temperature	288.15 K		
<b>8 - ANALOG OUTPUT</b>			
81 output	disabled		
82 rate-min	0000000		
83 rate-max	9999999		
84 cut-off	0.0%		
85 tune-min	0208		
86 tune-max	6656		
87 filter	0 (off)		
<b>9 - PULSE</b>			
91 width	0 (off)		
92 decimals	0		
93 amount	1.000		
<b>A - COMMUNICATION</b>			
A1 speed	9600		
A2 address	1		
A3 mode	BUS-RTU		
<b>B - OTHERS</b>			
B1 model	F126-P		
B2 software version			
B3 serial no.			
B4 password	0000		
B5 tag-nr	0000000		

**Fluidwell B.V.**

PO box 6  
5460 AA Veghel  
the Netherlands

Voltaweg 23  
5466 AZ Veghel  
the Netherlands

Website: [www.fluidwell.com](http://www.fluidwell.com)

Find your nearest representative: [www.fluidwell.com/representatives](http://www.fluidwell.com/representatives)

© 2017 Fluidwell B.V.: FW\_F126PELTP\_v1702\_02\_EN