

# *F090-A-PL*

*LOOP POWERED INDICATOR*

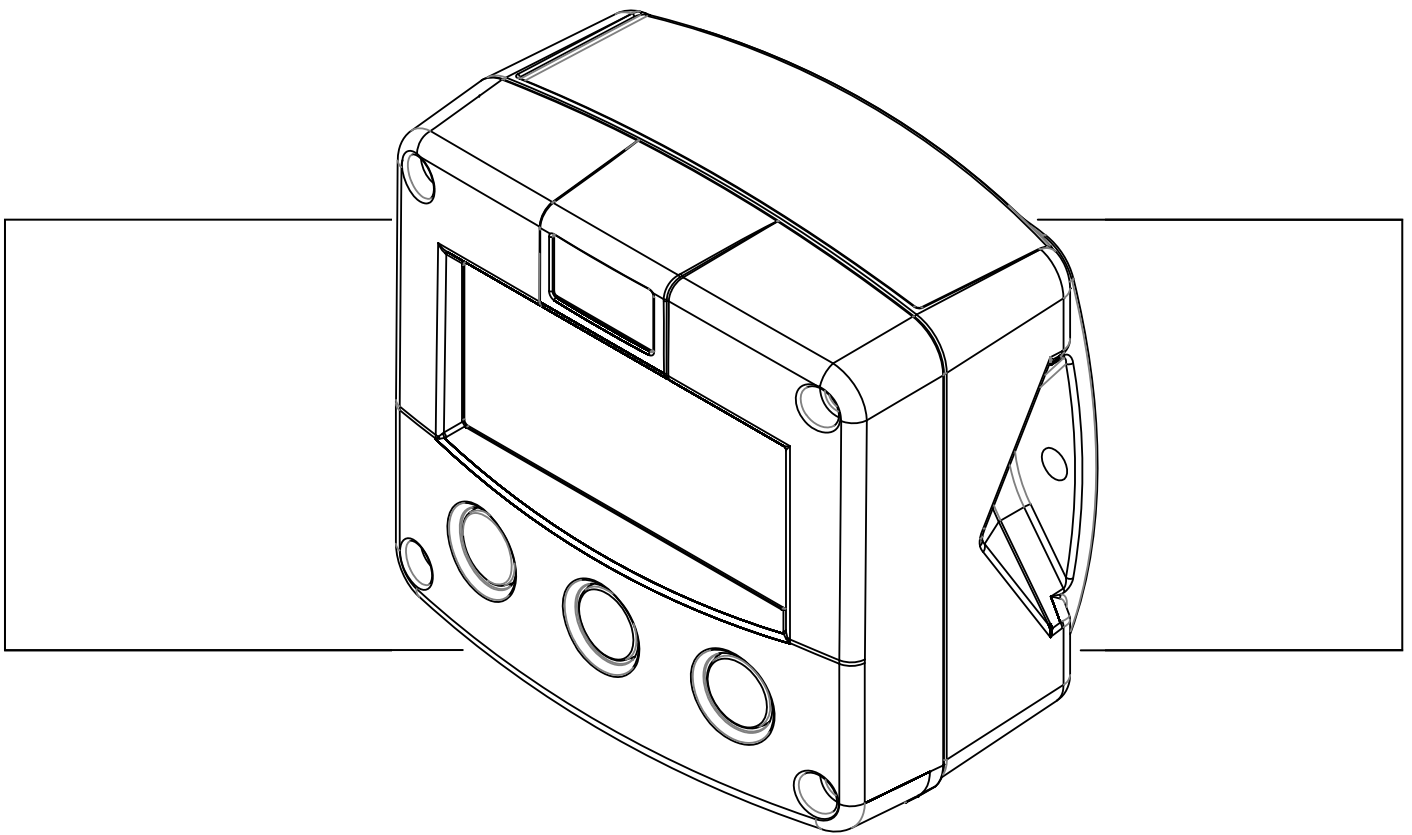

*Signal input sensor: 4-20mA.*

*Options: Intrinsically Safe.*



## SAFETY INSTRUCTIONS



- Any responsibility is lapsed if the instructions and procedures as described in this manual are not followed.
- **LIFE SUPPORT APPLICATIONS:** The F090-A-PL is not designed for use in life support appliances, devices, or systems where malfunction of the product can reasonably be expected to result in a personal injury. Customers using or selling these products for use in such applications do so at their own risk and agree to fully indemnify the manufacturer and supplier for any damages resulting from such improper use or sale.
- Electro static discharge does inflict irreparable damage to electronics! Before installing or opening the unit, the installer has to discharge himself by touching a well-grounded object.
- This unit must be installed in accordance with the EMC guidelines (Electro Magnetic Compatibility).
- Do connect a proper grounding to the aluminum casing as indicated if the F090-A-PL has been supplied with the 115-230V AC power-supply type PM. The green / yellow wire between the back-casing and removable terminal-block may never be removed.
- **Intrinsically Safe applications:** follow the instructions as mentioned in Chapter 5 and consult "Fluidwell F0...-XI - Documentation for Intrinsic Safety".

## DISPOSAL



- At the end of its life this product should be disposed of according to local regulations regarding waste electronic equipment. If a battery is present in this product it should be disposed of separately. The separate collection and recycling of your waste equipment will help to conserve natural resources and ensure that it is recycled in a manner that protects the environment.

## SAFETY RULES AND PRECAUTIONARY MEASURES

- The manufacturer accepts no responsibility whatsoever if the following safety rules and precautions instructions and the procedures as described in this manual are not followed.
- Modifications of the F090-A-PL implemented without preceding written consent from the manufacturer, will result in the immediate termination of product liability and warranty period.
- Installation, use, maintenance and servicing of this equipment must be carried out by authorized technicians.
- Check the mains voltage and information on the manufacturer's plate before installing the unit.
- Check all connections, settings and technical specifications of the various peripheral devices with the F090-A-PL supplied.
- Open the casing only if all leads are free of potential.
- Never touch the electronic components (ESD sensitivity).
- Never expose the system to heavier conditions than allowed according to the casing classification (see manufacture's plate and chapter 4.2.).
- If the operator detects errors or dangers, or disagrees with the safety precautions taken, then inform the owner or principal responsible.
- The local labor and safety laws and regulations must be adhered to.

## ABOUT THE OPERATION MANUAL

This operation manual is divided into two main sections:

- The daily use of the unit is described in chapter 2 "Operation". These instructions are meant for users.
- The following chapters and appendices are exclusively meant for electricians/technicians. These provide a detailed description of all software settings and hardware installation guidance.

This operation manual describes the standard unit as well as most of the options available. For additional information, please contact your supplier.

**A hazardous situation may occur if the F090-A-PL is not used for the purpose it was designed for or is used incorrectly. Please carefully note the information in this operating manual indicated by the pictograms:**



A "**warning**" indicates actions or procedures which, if not performed correctly, may lead to personal injury, a safety hazard or damage of the F090-A-PL or connected instruments.



Caution !

A "**caution**" indicates actions or procedures which, if not performed correctly, may lead to personal injury or incorrect functioning of the F090-A-PL or connected instruments.



Note !

A "**note**" indicates actions or procedures which, if not performed correctly, may indirectly affect operation or may lead to an instrument response which is not planned.

Hardware version	:	FB03.03.xx
Software version	:	03.03.xx
Manual	:	HF090APLEN_v0403_05 Atex_IECEX_CSA_FM
© Copyright 2012	:	Fluidwell bv - The Netherlands.

**Information in this manual is subject to change without prior notice. The manufacturer is not responsible for mistakes in this material or for incidental damage caused as a direct or indirect result of the delivery, performance or use of this material.**

**© All rights reserved. No parts of this publication may be reproduced or used in any form or by any means without written permission of your supplier.**

# CONTENTS MANUAL

Safety instructions .....	2
Disposal .....	2
Safety rules and precautionary measures .....	2
About the operation manual .....	3
Contents manual.....	4
1. Introduction .....	5
1.1. System description of the F090-A-PL .....	5
2.1. General .....	6
2.2. Control panel.....	6
2.3. Operator information and functions .....	7
3. Configuration .....	8
3.1. Introduction .....	8
3.2. Programming SETUP-level.....	8
3.2.1. General .....	8
3.2.2. Overview functions SETUP level .....	11
3.2.3. Explanation OF SETUP-functions.....	11
1 - Display .....	11
1 - Display (continued) .....	12
2 - Backlight .....	13
3 - Sensor .....	13
3 - Sensor (continued) .....	14
4 - Others .....	14
4. Installation .....	15
4.1. General directions .....	15
4.2. Installation / surrounding conditions .....	15
4.3. Dimensions- Enclosure .....	16
4.4. Installing the hardware.....	18
4.4.1. Introduction .....	18
4.4.2. Terminal connectors .....	18
5. Intrinsically safe applications.....	19
5.1. General information and instructions: .....	19
5.2. Terminal connectors Intrinsically Safe applications: .....	20
5.3. Configuration example Intrinsically Safe application: .....	21
5.4. Battery replacement instructions (if applicable) .....	22
6. Maintenance.....	23
6.1. General directions .....	23
6.2. Repair.....	23
Appendix A: Technical specification .....	24
Appendix B: Problem solving.....	26
Index of this manual.....	27
List of figures in this manual .....	27
List of configuration settings .....	28

## 1. INTRODUCTION

### 1.1. SYSTEM DESCRIPTION OF THE F090-A-PL

#### Functions and features

The general purpose indicator model F090-A-PL is a loop powered microprocessor driven instrument designed to display the actual value, like level, temperature, flow, pressure etc.

This product has been designed with a focus on:

- ultra-low power consumption to allow loop powered applications (type PL),
- intrinsic safety for use in hazardous applications (type XI),
- several mounting possibilities with GRP or aluminum enclosures for industrial surroundings,

#### Sensor input

This manual describes the unit with an analog 4-20mA input type from the sensor "-A version". One sensor with an active 4-20mA signal output can be connected to the F090-A-PL.

The F090-A-PL is powered from the loop (sensor signal) and does not require any additional external power supply.

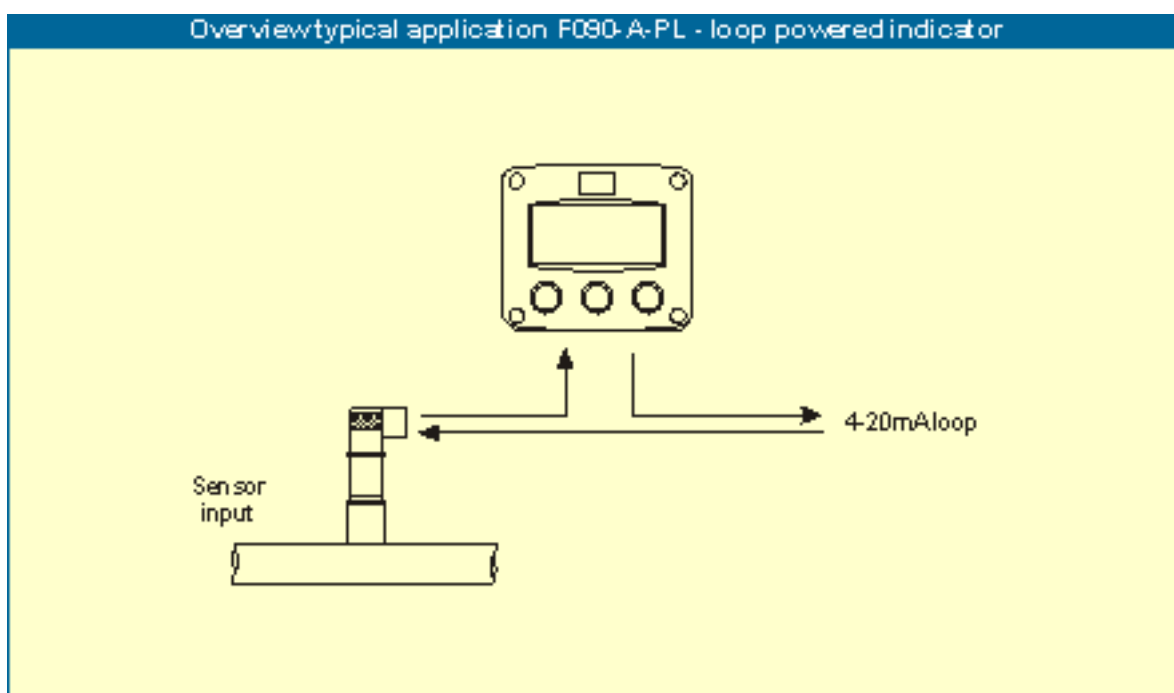

Fig. 1: Application example of the F090-A-PL.

#### Configuration of the unit

The F090-A-PL has been designed to be implemented in many types of applications. For that reason, a SETUP-level is available to configure your F090-A-PL according to your specific requirements.

It includes several important features, such as Span, measurement units, display options etc. All settings are stored in EEPROM memory and will not be lost in the event of power failure.

#### Display information

The unit has a large transreflective LCD with all kinds of symbols and digits to display measuring units, status information and key-word messages.

The actual values are displayed with the large 26mm (1") digits while the smaller 8mm (0.31") digits display the measuring unit and messages.

The Piegraph is percentage-wise related to the span.

#### Options

The following options are available: intrinsic safety, panel-mount, wall-mount and weather-proof enclosures, flame proof enclosure and LED backlight.

## 2. OPERATIONAL

### 2.1. GENERAL



- *The F090-A-PL may only be operated by personnel who are authorised and trained by the operator of the facility. All instructions in this manual are to be observed.*
- *Take careful notice of the " Safety rules, instructions and precautionary measures " in the front of this manual.*

This chapter describes the daily use of the F090-A-PL. This instruction is meant for users / operators.

### 2.2. CONTROL PANEL

The following keys are available:

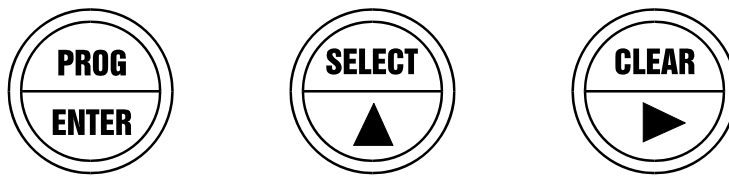

Fig. 2: Control Panel.

#### Functions of the keys



This key is used to program and save new values or settings. It is also used to gain access to SETUP-level; please read chapter 3.



This key is used to SELECT actual mA value, 0% and 100% value. The arrow-key ▲ is used to increase a value after PROG has been pressed or to configure the unit; please read chapter 3.



This key has no function at Operator level. The arrow-key ► is used to select a digit after PROG has been pressed or to configure the unit; please read chapter 3.

### 2.3. OPERATOR INFORMATION AND FUNCTIONS

In general, the F090-A-PL will always act at Operator level.



Fig. 3: Example of display information during process.

For the Operator, the following functions are available (if activated):

- **Display value and measuring unit**  
This is the main display information of the F090-A-PL. After selecting any other information, it will always return to this main display automatically.
- **Display actual mA value (if activated)**  
After pressing SELECT, the actual input current (mA) will be displayed.
- **Display 0% / 100% (if activated)**  
After pressing SELECT a few times, the 0% value (=4mA) and 100% value (=20mA) will be displayed.
- **Under range / over range**  
If the input current is in-between 3.5mA and 3.75mA "low range" will be displayed.  
If the input current is in-between 3.75mA and 4mA the value corresponding to 4mA will be displayed.  
If the input current is in-between 20 mA and 22mA the value will be extrapolated.  
If the input current is above 22mA the value "high range" will be displayed.

### 3. CONFIGURATION

#### 3.1. INTRODUCTION

This and the following chapters are exclusively meant for electricians and non-operators. In these, an extensive description of all software settings and hardware connections are provided.

- 
- Caution !
- *Mounting, electrical installation, start-up and maintenance of the instrument may only be carried out by trained personnel authorised by the operator of the facility. Personnel must read and understand this Operating Manual before carrying out its instructions.*
  - *The F090-A-PL may only be operated by personnel who are authorised and trained by the operator of the facility. All instructions in this manual are to be observed.*
  - *Ensure that the measuring system is correctly wired up according to the wiring diagrams. The housing may only be opened by trained personnel.*
  - *Take careful notice of the " Safety rules, instructions and precautionary measures " in the front of this manual.*

#### 3.2. PROGRAMMING SETUP-LEVEL

##### 3.2.1. GENERAL

Configuration of the F090-A-PL is done at SETUP-level. SETUP-level is reached by pressing the PROG/ENTER key for 7 seconds; at which time, both arrows  $\blacktriangleleft$  will be displayed. In order to return to the operator level, PROG will have to be pressed for three seconds. Alternatively, if no keys are pressed for 2 minutes, the unit will exit SETUP automatically.

SETUP can be reached at all times while the F090-A-PL remains fully operational.



Note !

**Note:** A pass code may be required to enter SETUP. Without this pass code access to SETUP is denied.

To enter SETUP-level:

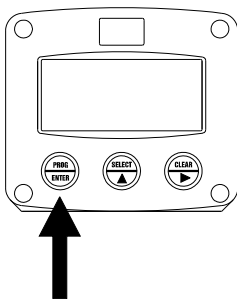

Press  for 7 seconds



Matrix structure SETUP-level:

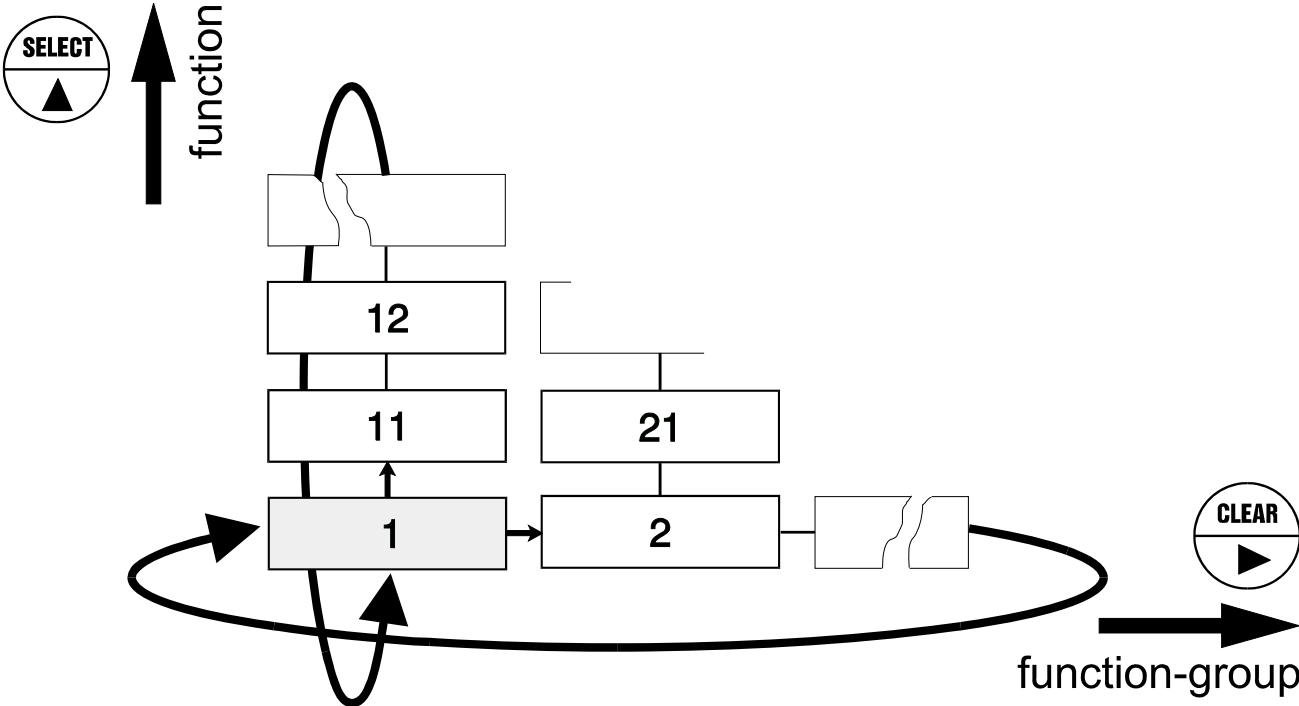

SCROLLING THROUGH SETUP-LEVEL

Selection of function-group and function:  
SETUP is divided into several function groups and functions.

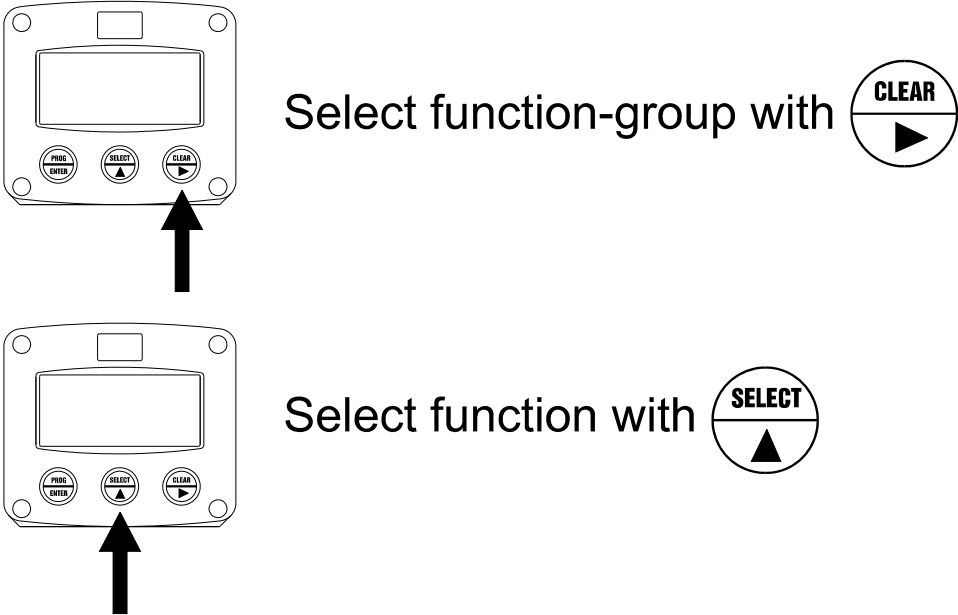





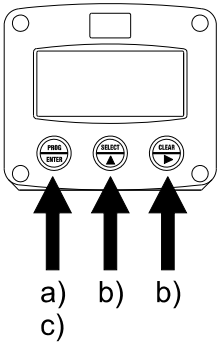

Each function has a unique number, which is displayed below the word "SETUP" at the bottom of the display. The number is a combination of two figures. The first figure indicates the function-group and the second figure the sub-function. Additionally, each function is expressed with a keyword.



After selecting a sub-function, the next main function is selected by scrolling through all "active" sub-functions (e.g. 1 ▲, 11 ▲, 12 ▲, 13 ▲, 14 ▲, 1 ►, 2 ►, 3 ▲, 31 etc.).



To change or select a value:



- a) press  briefly; **PROGRAM** will start flash
- b) select or enter value with  and / or 
- c) press  to confirm the value / selection.

To change a value, use  to select the digits and  to increase that value.

To select a setting, both  and  can be used.

If the new value is invalid, the increase sign  or decrease-sign  will be displayed while you are programming.

When data is altered but ENTER is not pressed, then the alteration can still be cancelled by waiting for 20 seconds or by pressing ENTER for three seconds: the PROG-procedure will be left automatically and the former value reinstated.



Note !

**Note:** alterations will only be set after ENTER has been pressed!

To return to OPERATOR-level:

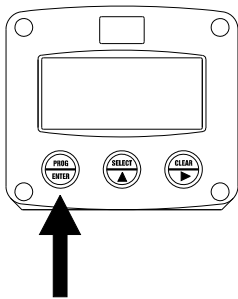

Press  for 3 seconds

In order to return to the operator level, PROG will have to be pressed for three seconds. Also, when no keys are pressed for 2 minutes, SETUP will be left automatically.

## 3.2.2. OVERVIEW FUNCTIONS SETUP LEVEL

SETUP FUNCTIONS AND VARIABLES			
<b>1</b>	<b>DISPLAY</b>		
	11	UNIT	mL - L - nL - M3 - nM3 - mg - g - kg - ton - gal - sgal - igal - lb - bbl - cf - scf - p - rev - °C - °F - °K - % - m - mm - cm - mtr - inch - ft - psi - mbar - bar - barg - mmwk - mmwc - cmwk - cmwc - mwk - mwc - inwc - ftwc - Ph - mV - no unit.
	12	TIME UNIT	sec - min - hour - day - no unit (-----)
	13	DECIMALS	0 - 1 - 2 - 3 - 4 - 5 (Ref: displayed value)
	14	OFFSET	-99.999 to +199.999
	15	SPAN	0.00001 to 199,999 unit/time-unit
	16	DIRECTION	reverse - normal
	17	CURRENT	on - off
	18	PERCENTAGE	on - off
	19	BARGRAPH	on - off
<b>2</b>	<b>BACKLIGHT</b>		
	21	BACKLIGHT (optional)	off - green - amber
	22	BL. BRIGHTNESS	1 - 5
<b>3</b>	<b>SENSOR</b>		
	31	FORMULA	interpolation, square root
	32	FILTER	00 - 99
	33	CALIBRATE LOW - 4mA	default - set - calibrate
	34	CALIBRATE HIGH - 20mA	default - set - calibrate
<b>4</b>	<b>OTHERS</b>		
	41	MODEL	F090-A
	42	SOFTWARE VERSION	03-03-xx
	43	SERIAL NO.	
	44	PASSWORD	0000 - 9999
	45	TAGNUMBER	0000000 - 9999999

## 3.2.3. EXPLANATION OF SETUP-FUNCTIONS

1 - DISPLAY	
<b>UNIT 11</b>	<p>SETUP - 21 determines the measurement unit to be displayed. The following units can be selected:</p> <p>mL - L - nL - M3 - nM3 - mg - g - kg - ton - gal - sgal - igal - lb - bbl - cf = scf - p - rev - °C - °F - °K - % - m - mm - cm - mtr - inch - ft - psi - mbar = bar - barg - mmwk - mmwc - cmwk - cmwc - mwk - mwc - inwc - ftwc - Ph - mV - no unit.</p> <p>Alteration of the measurement unit will have consequences for other SETUP-level values. Please note that the Span has to be adapted as well; the calculation is not done automatically.</p>
<b>TIME UNIT 12</b>	<p>For flowrate calculations, a time unit can be set. The flowrate can be calculated per second (SEC), minute (MIN), hour (HR) or day (DAY). Do select "-----" if no time is desired.</p>
<b>DECIMALS 13</b>	<p>This setting determines the number of digits following the decimal point. The following can be selected:</p> <p>000000 - 11111.1 - 222.22 - 33.333 - 4.4444 - .55555</p>
Continued next page >>>	

<b>1 - DISPLAY (CONTINUED)</b>	
<b>OFFSET</b> <b>14</b>	<p>The unit need to know the value at minimum signal. The following range can be programmed:</p> <p style="text-align: center;">-99,999 to + 199,999</p> <p>The <b>minus</b> for a <b>negative</b> value can selected by pressing the centre and right button simultaneously.</p>
<b>SPAN</b> <b>15</b>	<p>With the span, the sensor signal is converted to a certain value. The <b>span</b> is determined on the basis of the <b>selected measurement and time unit</b> at 20mA. The more accurate the span, the more accurate the functioning of the system will be. The following range can be programmed:</p> <p style="text-align: center;">0.00001 to + 199,999</p> <p><b>Example 1     Calculating the span for a level measurement application:</b> <i>Let us assume that the sensor generates 20mA at a level of 2,481.3 Liters, the selected unit is "Liters" and one decimal.</i> <i>The span is 2481.3</i> <i>Enter:</i> <i>SETUP 11: "L"</i> <i>SETUP 12: "1111.1"</i> <i>SETUP 13: "2481.3"</i> <i>SETUP 14 "0.00".</i></p> <p><b>Example 2     Calculating the span for a level measurement Application with an offset:</b> <i>Let us assume that the sensor generates 4mA at a level of 200.00 USGAL and 20mA at a level of 652.31 USGAL, the selected unit is "USG" and two decimals.</i> <i>The span is 652.31-200=452.31.</i> <i>Enter:</i> <i>SETUP 11: "USG"</i> <i>SETUP 12: "222.22"</i> <i>SETUP 13: "452.31"</i> <i>SETUP 14 "200.00".</i></p>
<b>DIRECTION</b> <b>16</b>	<p>If the display is required to increase in value as the input current increases, select the scale direction "normal". Alternatively, select "reverse" if the display is required to decrease as the input current rises.</p>
<b>CURRENT</b> <b>17</b>	<p>Do select "ON" if you want the actual current value to be displayed for the operator.</p>
<b>PERCENTAGE</b> <b>18</b>	<p>Do select "ON" if you want to display the 0% value (value at minimum sensor signal) and 100% (value at maximum sensor signal).</p>
<b>BARGRAPH</b> <b>19</b>	<p>The bargraph (piegraph) displayed at operator level is percentage-wise related to the input signal: minimum signal is 0% (setup 33) and maximum signal is 100% (setup 34). With this function, the bargraph can be enabled / disabled. Following selections are available:</p> <p style="text-align: center;">OFF - ON</p>

## 2 - BACKLIGHT

The functions below will only effect the optional LED-backlight.

<b>BACKLIGHT (OPTION)</b> 21	If a LED backlight has been supplied, the color can be selected. Following selections are available:  <p style="text-align: center;">OFF - GREEN - AMBER</p>
<b>BRIGHTNESS (OPTION)</b> 22	The density of the backlight can be set in following range:  <p style="text-align: center;">1 - 5</p> One is minimum and five is maximum brightness.

## 3 - SENSOR

<b>FORMULA</b> 31	The F090-A-PL can process the 4-20mA signal in two ways: <ul style="list-style-type: none"> <li>▪ Interpolation: the signal is processed linear  <math display="block">V = S \times I</math></li> <li>▪ Square root: for differential pressure  <math display="block">V = S \sqrt{I}</math></li> </ul> <p>where:  V = Value: the calculated value  S = Span: the value at maximum signal (Span). The Span is programmed with setting 14.  I = Input: the scaled analogue input value; in these formulas value 0 (zero) for (0)4mA and value 1 (one) for 20mA.</p>
----------------------	---

<b>FILTER</b> 32	The analogue output signal of a sensor does mirror a value. This value is measured several times a second by the F090-A-PL. The value measured is a "snap-shot" of the real signal as it will be fluctuating. With the help of this digital filter a stable and accurate reading can be obtained while the filter level can be set to a desired value. The filter principal is based on three input values: the filter level (01-99), the last measured analogue value and the last average value. The higher the filter level, the longer the response time on a value change will be. Below, several filter levels with there response times are indicated:
---------------------	--





Note !

FILTER VALUE	RESPONSE TIME ON STEP CHANGE OF ANALOG VALUE.			
	TIME IN SECONDS			
	50% INFLUENCE	75% INFLUENCE	90% INFLUENCE	99% INFLUENCE
01	filter disabled	filter disabled	filter disabled	filter disabled
02	0.3 seconds	0.5 seconds	1.0 seconds	1.8 seconds
03	0.5 seconds	1.0 seconds	1.5 seconds	3 seconds
05	1.0 seconds	1.8 seconds	2.8 seconds	5.3 seconds
10	1.8 seconds	3.5 seconds	5.6 seconds	11 seconds
20	3.5 seconds	7.0 seconds	11 seconds	23 seconds
50	8.8 seconds	17 seconds	29 seconds	57 seconds
75	13 seconds	26 seconds	43 seconds	86 seconds
99	17 seconds	34 seconds	57 seconds	114 seconds

Continued next page >>>

### 3 - SENSOR (CONTINUED)

<b>CALIBRATE LO - 4mA</b> <b>33</b>	<p>With this setting it is possible to calibrate the input value for 4mA as the signal from the sensor might not be exact 4.0 mA at minimum signal.</p> <ul style="list-style-type: none"> <li>▪ <b>Warning:</b> <i>be very sure that the offered signal is correct before the calibration is executed as this function has major influences on the accuracy of the system!</i></li> </ul> <p>After pressing PROG, three settings can be selected:</p> <ul style="list-style-type: none"> <li>▪ CALIB (calibrate): with this setting, the input will be calibrated with the actual "(0)4mA" value. After pressing enter, TUNED will be displayed as soon as the calibration is completed. From that moment, the analog value must be more than the calibrated value before the signal will be processed.</li> <li>▪ DFLT.: with this setting, the factory value is re-installed.</li> <li>▪ SET: to select the last calibrated value.</li> </ul> <p><i>Remark: the analog input value can be programmed "up-side-down" if desired, so 4mA at maximum value for example! Also, any value is allowed with it's range of 4-20mA.</i></p>	
<b>CALIBRATE HI - 20mA</b> <b>34</b>	<p>With this setting it is possible to calibrate the input value for 20mA as the signal from the sensor might not be exact 20.0 mA at maximum signal.</p> <ul style="list-style-type: none"> <li>▪ <b>Warning:</b> <i>be very sure that the offered signal is correct before the calibration is executed as this function has major influences on the accuracy of the system!</i></li> </ul> <p>After pressing PROG, three settings can be selected:</p> <ul style="list-style-type: none"> <li>▪ CALIB (calibrate): with this setting, the input will be calibrated with the actual "20mA" value. After pressing enter, TUNED will be displayed as soon as the calibration is completed. From that moment, the analog value must be less than the calibrated value for a reliable measurement.</li> <li>▪ DFLT.: with this setting, the manufactures value is re-installed.</li> <li>▪ SET: to select the last calibrated value.</li> </ul> <p><i>Remark: the analog input value can be programmed "up-side-down" if desired, so 20mA at minimum value for example! Also, any value is allowed with it's range of 4-20mA.</i></p>	

### 4 - OTHERS

<b>TYPE OF MODEL</b> <b>41</b>	<p>For support and maintenance it is important to have information about the characteristics of the F090-A-PL. Your supplier will ask for this information in the case of a serious breakdown or to assess the suitability of your model for upgrade considerations.</p>
<b>VERSION SOFTWARE</b> <b>42</b>	<p>For support and maintenance it is important to have information about the characteristics of the F090-A-PL. Your supplier will ask for this information in the case of a serious breakdown or to assess the suitability of your model for upgrade considerations.</p>
<b>SERIAL NUMBER</b> <b>43</b>	<p>For support and maintenance it is important to have information about the characteristics of the F090-A-PL. Your supplier will ask for this information in the case of a serious breakdown or to assess the suitability of your model for upgrade considerations.</p>
<b>PASS CODE</b> <b>44</b>	<p>All SETUP-values can be pass code protected. This protection is disabled with value 0000 (zero). Up to and including 4 digits can be programmed, for example 1234.</p>
<b>TAGNUMBER</b> <b>45</b>	<p>For identification of the unit and communication purposes, a unique tag number of maximum 7 digits can be entered.</p>

## 4. INSTALLATION

### 4.1. GENERAL DIRECTIONS



- *Mounting, electrical installation, start-up and maintenance of this instrument may only be carried out by trained personnel authorised by the operator of the facility. Personnel must read and understand this Operating Manual before carrying out its instructions.*
- *The F090-A-PL may only be operated by personnel who are authorised and trained by the operator of the facility. All instructions in this manual are to be observed.*
- *Ensure that the measuring system is correctly wired up according to the wiring diagrams. Protection against accidental contact is no longer assured when the housing cover is removed or the panel cabinet has been opened (danger from electrical shock). The housing may only be opened by trained personnel.*
- *Take careful notice of the " Safety rules, instructions and precautionary measures " at the front of this manual.*

### 4.2. INSTALLATION / SURROUNDING CONDITIONS

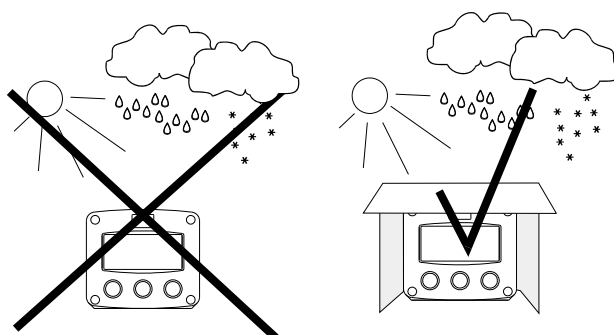

Take the relevant IP classification of the casing into account (see manufactures plate). Even an IP67 (NEMA 4X) casing should NEVER be exposed to strongly varying (weather) conditions.

When panel-mounted, the unit is IP65 (NEMA 4)!

When used in very cold surroundings or varying climatic conditions, take the necessary precautions against moisture by placing a dry sachet of silica gel, for example, inside the instrument case.

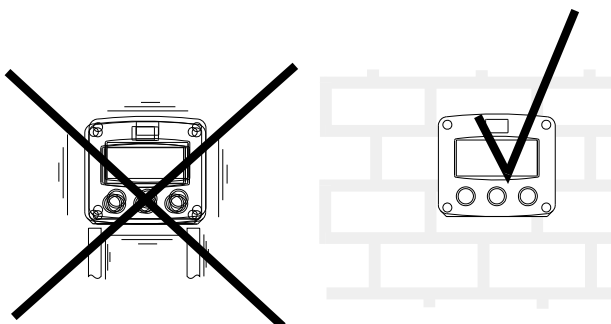

Mount the F090-A-PL on a solid structure to avoid vibrations.

4.3. DIMENSIONS- ENCLOSURE

Aluminum enclosures:

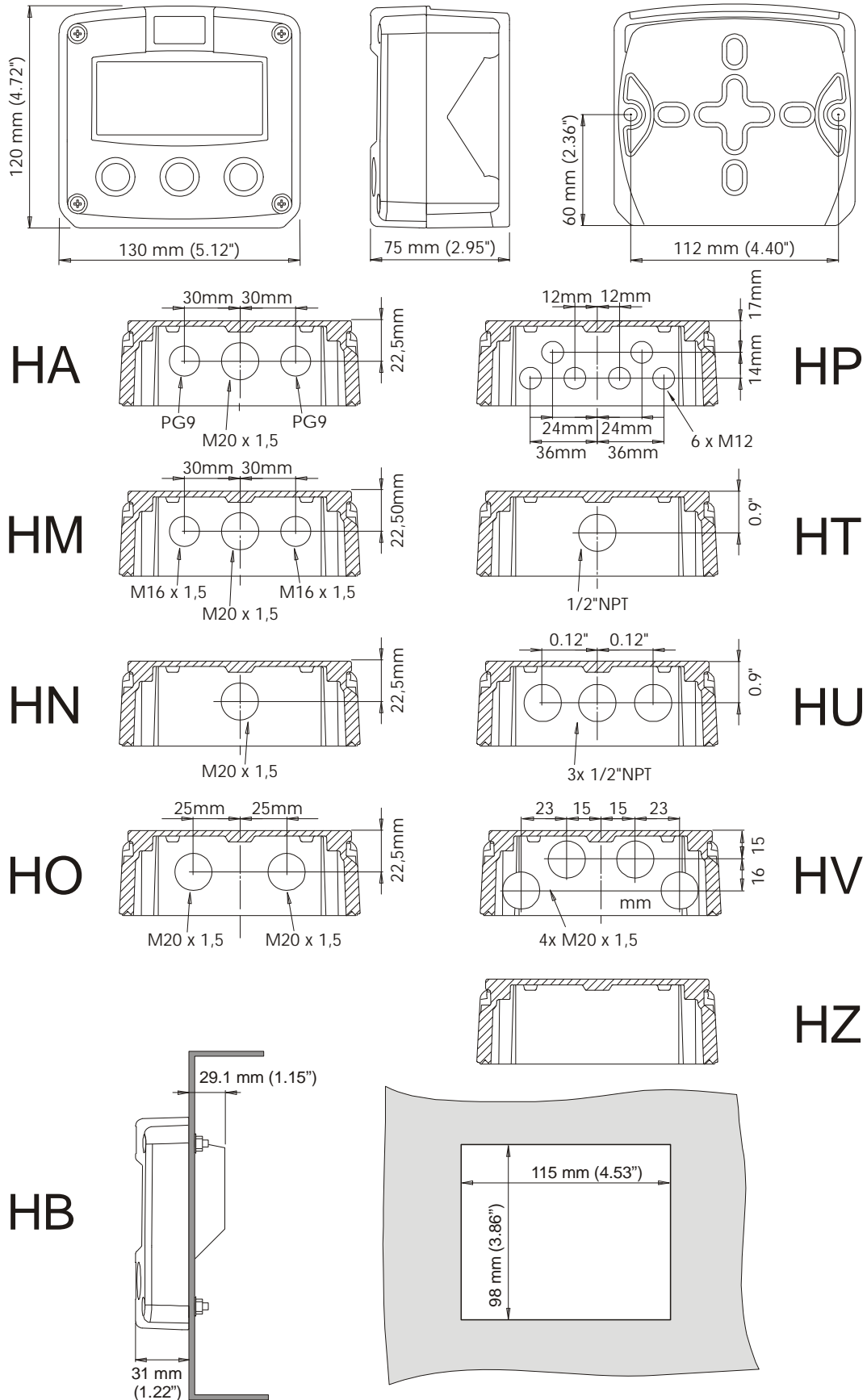
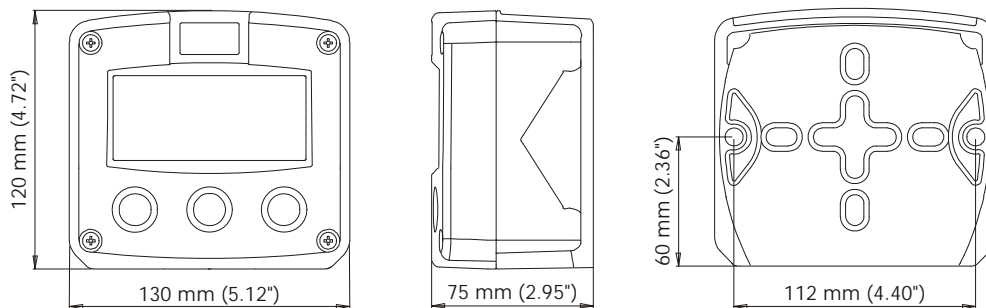

Fig. 4: Dimensions Aluminum enclosures.



GRP enclosures:



HK back box:  
(flat bottom)

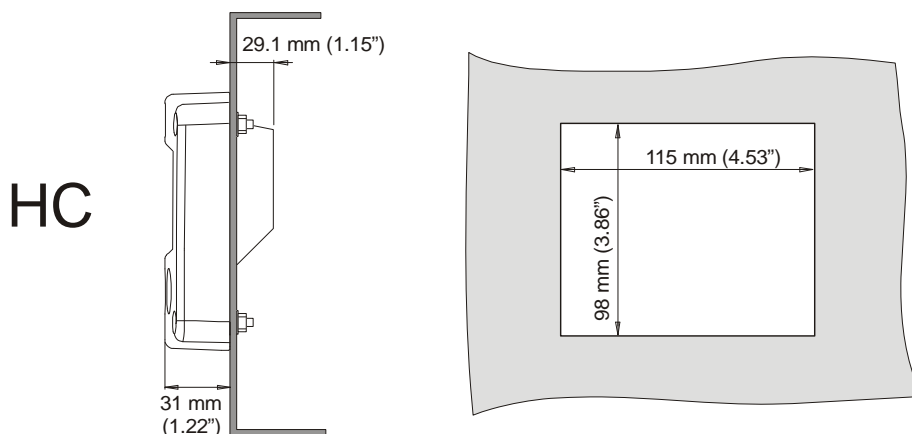
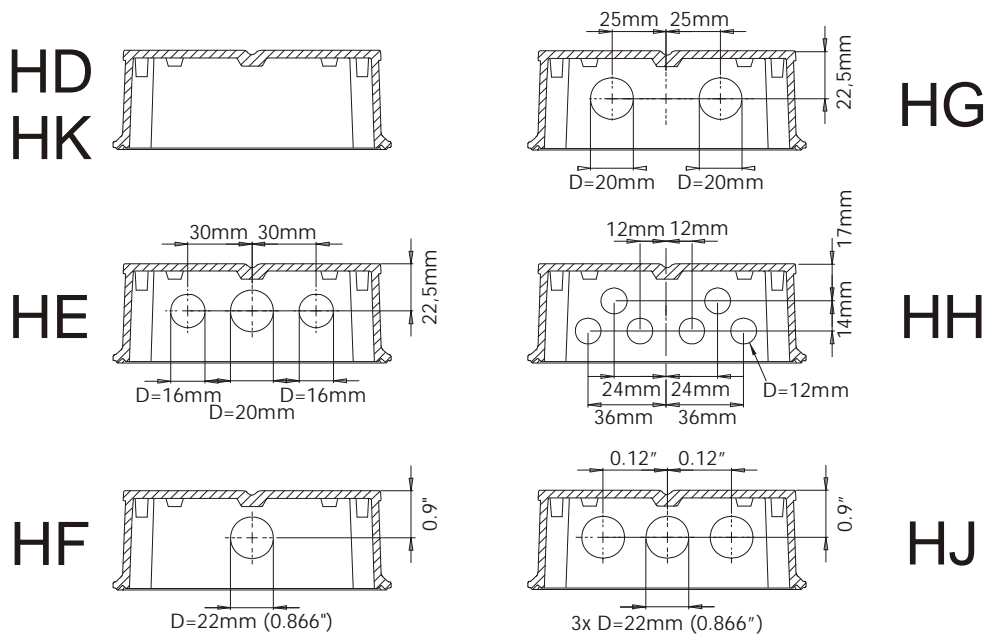
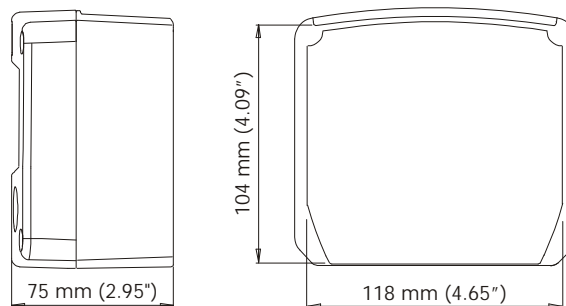

Fig. 5: Dimensions GRP enclosures.

4.4. INSTALLING THE HARDWARE

4.4.1. INTRODUCTION



▪ *Electro static discharge does inflict irreparable damage to electronics! Before installing or opening the unit, the installer has to discharge himself by touching a well-grounded object.*



▪ *This unit must be installed in accordance with the EMC guidelines (Electro Magnetic Compatibility).*

**FOR INSTALLATION, PAY EMPHATIC ATTENTION TO:**

- Separate cable glands with effective IP67 (NEMA4X) seals for all wires.
- Unused cable entries: ensure that you fit IP67 (NEMA4X) plugs to maintain rating.
- A reliable ground connection for both the sensor, and if applicable, for the metal casing. (above)
- An effective screened cable for the input signal, and grounding of it's screen or at the sensor itself, whichever is appropriate to the application.

4.4.2. TERMINAL CONNECTORS

For *Intrinsically Safe* applications: read chapter 5.

The following terminal connectors are available:

SENSOR SIGNAL  
ANALOG INPUT  
TYPE: A-PL 4-20mA

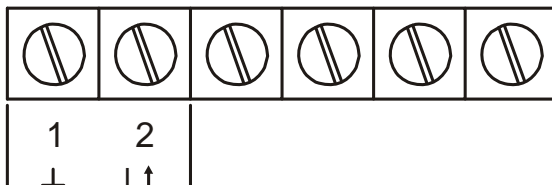

POWER SUPPLY  
BACKLIGHT  
OPTION: ZB

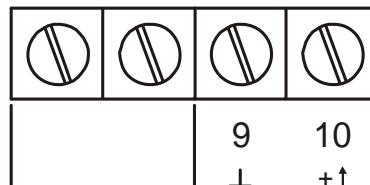

Fig. 6: Overview of terminal connectors standard configuration F090-A-PL and options.

**REMARKS: TERMINAL CONNECTORS:**

**Terminals 1-2; sensor INPUT LOOP POWERED 4-20mA - type A-PL:**

Model F090-A-PL is powered from the 4-20mA sensor signal. The unit will process the signal four times a second with a 16 bits accuracy. The input is not isolated.

The screen of the signal wire must be connected to the common ground terminal.

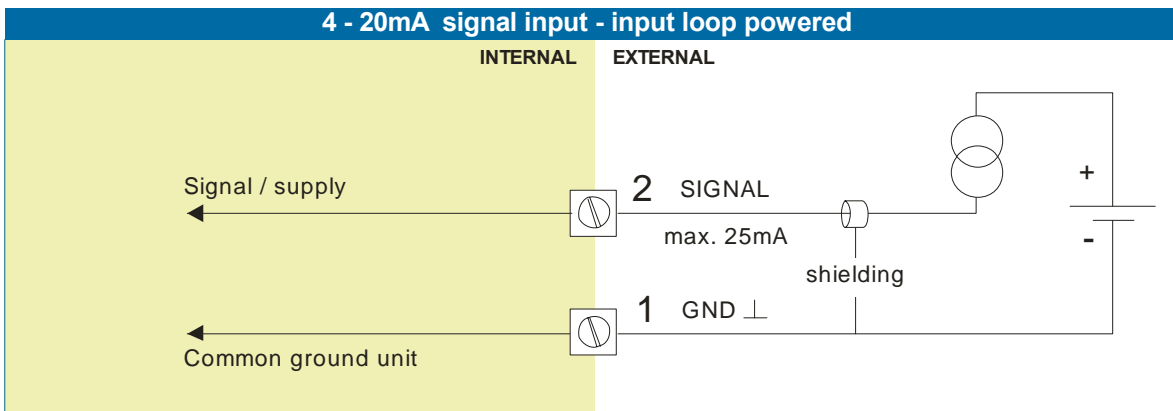

**Terminal 9-10: power supply backlight - type ZB (option):**

To power the backlight, a voltage in the range 20-30V DC has to be connected. Maximum current 30mA. Connect the "-" to terminal 9 and the "+" to terminal 10.

## 5. INTRINSICALLY SAFE APPLICATIONS

### 5.1. GENERAL INFORMATION AND INSTRUCTIONS:



- *Mounting, electrical installation, start-up and maintenance of this device may only be carried out by trained personnel authorized by the operator of the facility. Personnel must read and understand this Operating Manual before carrying out its instructions.*
- *This device may only be operated by personnel who are authorized and trained by the operator of the facility. All instructions in this manual are to be observed.*
- *Ensure that the measuring system is correctly wired up according to the wiring diagrams. Protection against accidental contact is no longer assured when the housing cover is removed or the cabinet has been opened (danger of electric shock). The housing may only be opened by trained personnel.*
- *Take careful notice of the " Safety rules, instructions and precautionary measures " in the front of this manual.*

### Safety Instructions



- *Certificates, safety values, control drawing and declaration of compliance can be found in the document named: "Fluidwell F0..-A-XI - Documentation for Intrinsic Safety".*
- *For installation under ATEX directive: this intrinsically safe device must be installed in accordance with the Atex directive 94/9/EC and the product certificate KEMA 05ATEX1168 X.*
- *For installation under IECEx scheme: this intrinsically safe device must be installed in accordance the product certificate IECEx KEM 08.0006X.*
- *For installation under CSA: this intrinsically safe device must be installed in accordance with the product certificate CSA.08.2059461 X.*
- *For installation under FM: this intrinsically safe device must be installed in accordance with the Certificate / Project ID: 3033306.*
- *The control drawing number FWCD-0001 can be found in the document named: "Fluidwell F0..-A-XI - Documentation for Intrinsic Safety".*
- *The control drawing number FWCD-0002 can be found in the document named: "Fluidwell F0..-A-PL-XI - Documentation for Intrinsic Safety".*
- *Exchange of Intrinsically Safe battery FWLiBAT-00x with certificate number KEMA 03ATEX1071 U or IECEx KEM 08.0005U is allowed in Hazardous Area. See paragraph 5.4. for battery replacement instructions.*

### Please note



- *Special conditions for safe use mentioned in both the certificate and the installation instructions must be observed for the connection of power to both input and / or output circuits.*
- *When installing this device in hazardous areas, the wiring and installation must comply with the appropriate installation standards for your industry.*
- *Study the following pages with wiring diagrams per classification.*

### Serial number and year of production

This information can be looked-up on the display setup function (par. 3.2.2.). :

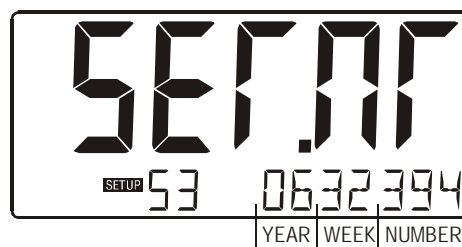

Fig. 7: Example serial number.

**Label information analog input - loop powered - type A-PL (inside and outside the enclosure)**

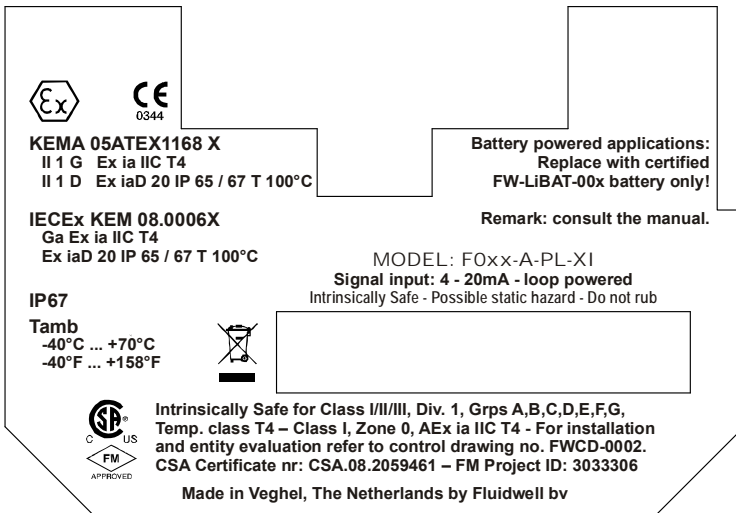
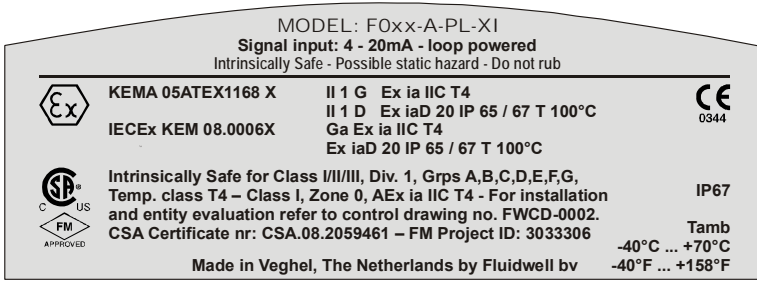

Fig. 8: Label information Intrinsically Safe application.

**5.2. TERMINAL CONNECTORS INTRINSICALLY SAFE APPLICATIONS:**

**Terminal connectors F090-A-PL-XI-(ZB):**

SENSOR SIGNAL  
ANALOG INPUT  
TYPE: A-PL 4-20mA

POWER SUPPLY  
BACKLIGHT  
OPTION: ZB

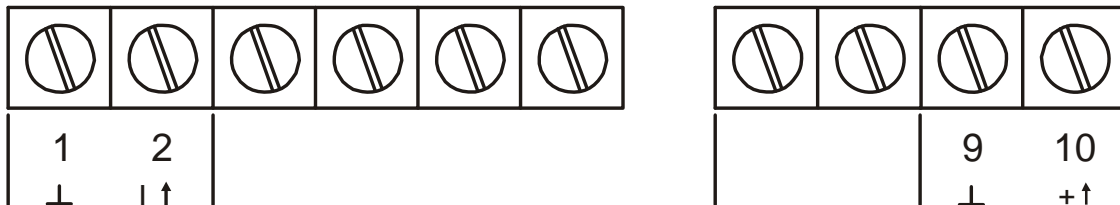

Fig. 9: Overview terminal connectors XI - Intrinsically Safe applications.

**Power supply:**

**Type PL:** the F090-A-PL-XI will be powered from the 4-20mA input signal.

5.3. CONFIGURATION EXAMPLE INTRINSICALLY SAFE APPLICATION:

Configuration example

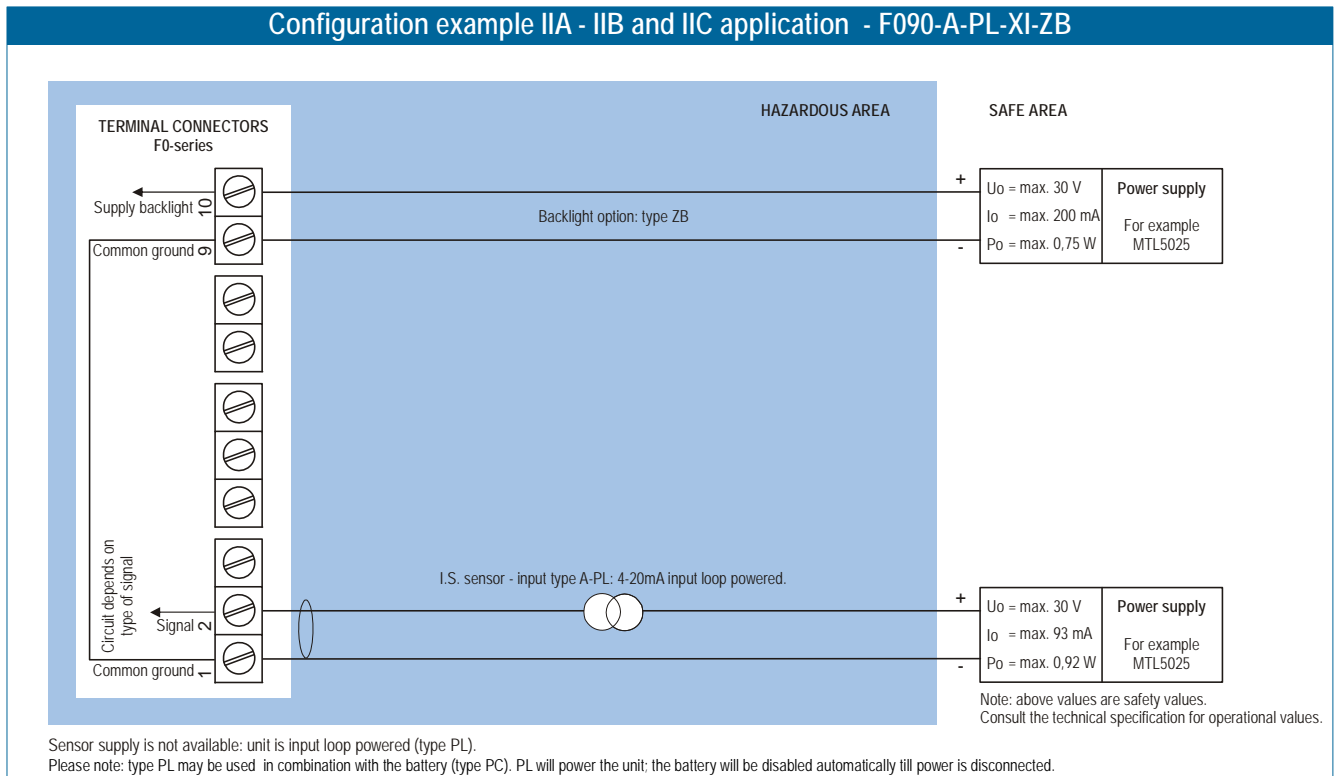

Fig. 10: Configuration example Intrinsically Safe.

5.4. BATTERY REPLACEMENT INSTRUCTIONS (IF APPLICABLE)

INSTRUCTION SHEET BATTERY REPLACEMENT FW-LiBAT-001

FW-LiBAT-001 - INST001

**Manufacturer**  
Fluidwell bv - The Netherlands  
www.fluidwell.com - sales@fluidwell.com

**Safety Instructions**  
**WARNING:** Fire, explosion or severe burns may result if mistreated. Do not recharge, crush, disassemble, incinerate, heat above 100°C (212°F) or expose contents to water.

**Replacement Instructions**  
Mounting, electrical installation, start-up and maintenance of this device may only be carried out by trained personnel authorized by the operator of the facility.  
Personnel must read and understand this Instruction before carrying out its instructions.

It is allowed to replace the Intrinsically Safe battery FW-LiBAT-001 in hazardous area. The battery may only be replaced with an original FW-LiBAT-001 manufactured by Fluidwell bv.

For replacement, unplug the connector carefully and lift the old battery out of the mounting clip. The new battery can be placed in the clip and the connector plugged on the board.

**Disposal**  
Disposal should be done in accordance with applicable regulations, which vary from country to country. Trashing of used batteries is forbidden and disposal can be done through non-profit organizations mandated by local authorities or organized by professionals.

**Battery label:**

0344       II 1 G    Ex ia IIC    KEMA 03ATEX1071 U  
 Fluidwell bv - Intrinsically Safe Battery    Consult manual for replacement instructions.  
 Part. no.: FW-LiBAT-001    **WARNING:** Fire, explosion or severe burns may result if mistreated. Do not recharge, crush, disassemble, incinerate, heat above 100°C (212°F) or expose contents to water.  
 Uo = 3.9V    Co = 100µF  
 Io = 35mA    Lo = 25mH  
 Po = 35mW    Ta = -40°C to +70°C  
**Primary Lithium Battery - Only replace with Fluidwell I.S. battery pack !**

**F0-series:**

Fig. 11: Battery replacement instructions Intrinsically Safe Battery.

## 6. MAINTENANCE

### 6.1. GENERAL DIRECTIONS



- *Mounting, electrical installation, start-up and maintenance of the instrument may only be carried out by trained personnel authorized by the operator of the facility. Personnel must read and understand this Operating Manual before carrying out its instructions.*
- *The F090-A-PL may only be operated by personnel who are authorized and trained by the operator of the facility. All instructions in this manual are to be observed.*
- *Ensure that the measuring system is correctly wired up according to the wiring diagrams. Protection against accidental contact is no longer assured when the housing cover is removed or the panel cabinet has been opened (danger from electrical shock). The housing may only be opened by trained personnel.*
- *Take careful notice of the " Safety rules, instructions and precautionary measures " in the front of this manual.*

The F090-A-PL does not require special maintenance unless it is used in low-temperature applications or surroundings with high humidity (above 90% annual mean). It is the users responsibility to take all precautions to dehumidify the internal atmosphere of the F090-A-PL in such a way that no condensation will occur, for example by placing dry silica-gel sachet in the casing just before closing it. Furthermore, it is required to replace or dry the silica gel periodically as advised by the silica gel supplier.

#### **Check periodically:**

- The condition of the casing, cable glands and front panel.
- The input/output wiring for reliability and aging symptoms.
- The process accuracy. As a result of wear and tear, re-calibration of the sensor might be necessary. Do not forget to re-enter any subsequent span alterations.
- The indication for low-battery.
- Clean the casing with soapy-water. Do not use any aggressive solvents as these might damage the coating.

### 6.2. REPAIR

This product cannot be repaired by the user and must be replaced with an equivalent certified product. Repairs should only be carried out by the manufacturer or his authorized agent.

## APPENDIX A: TECHNICAL SPECIFICATION

### GENERAL

Display	
Type	High intensity reflective numeric and alphanumeric LCD, UV-resistant.
Digits	5 ½ 26mm (1") and eleven 8mm (0.31"). Various symbols and measuring units.
Piegraph	10 segment range indication in relation to its measuring range 0-100%
Refresh rate	1 times/sec.
Type ZB (option)	Bi-color configurable LED-backlight - green or amber. Intensity adjustable from the keyboard.

Enclosures	
General	Die-cast aluminum or GRP (Glassfibre Reinforced Polyamide) enclosure with Polycarbonate window, silicone and EPDM gaskets. UV stabilized and flame retardant material.
Control Keys	Three industrial micro-switch keys. UV-resistant silicone keypad.
Painting	Aluminum enclosure only: UV-resistant 2-component industrial painting.
Panel-mount enclosures	Dimensions: 130 x 120 x 60mm (5.10" x 4.72" x 2.38") – LxHxD.
Classification	IP65 / NEMA4
Panel cut-out	115 x 98mm (4.53" x 3.86") LxH.
Type HC	GRP panel-mount enclosure
Type HB	Aluminum panel-mount enclosure
Field/wall-mount enclosures	Dimensions: 130 x 120 x 75mm (5.10" x 4.72" x 2.95") – LxHxD.
Classification	IP67 / NEMA4X
Aluminum enclosures	
Type HA	Drilling: 2x PG9 – 1x M20.
Type HM	Drilling: 2x M16 – 1x M20.
Type HN	Drilling: 1x M20.
Type HO	Drilling: 2x M20.
Type HP	Drilling: 6x M12.
Type HT	Drilling: 1x ½"NPT.
Type HU	Drilling: 3x ½"NPT.
Type HV	Drilling: 4x M20
Type HZ	No drilling.
GRP enclosures	
Type HD	No drilling.
Type HE	Drilling: 2x 16mm (0.63") – 1x 20mm (0.78").
Type HF	Drilling: 1x 22mm (0.87").
Type HG	Drilling: 2x 20mm (0.78").
Type HJ	Drilling: 3x 22mm (0.87").
Type HH	Drilling: 6x 12mm (0.47").
Type HK	Flat bottom - no drilling.

Operating temperature	
Operational	-40°C to +80°C (-40°F to +178°F).
Intrinsically Safe	-40°C to +70°C (-40°F to +158°F).

Power requirements	
Type PL	Input loop powered from 4-20mA signal input. Voltage drop max. 2.6V DC
Type ZB (backlight)	20-30V DC. Power consumption max. 1 Watt.
Note I.S. application	for intrinsically safe applications, consult the safety values in the certificate.

Terminal connections	
Type:	Removable plug-in terminal strip. Wire max. 1.5mm2

Data protection	
Type	EEPROM backup of all setting. Data retention at least 10 years.
Pass code	Configuration settings can be pass code protected.



Hazardous area (option)	
Intrinsically safe Type XI	<b>ATEX approval:</b> II 1 G Ex ia IIC T4 II 1 D Ex iaD 20 IP 65 / 67 T 100°C  <b>IECEX approval:</b> Ga Ex ia IIC T4 Ex iaD 20 IP 65 / 67 T 100°C  <b>CSA / FM approval :</b> IS Class I/II/III, Division 1 Groups A to G T4 Class I zone 0 AEx ia IIC T4

Environment	
Electromagnetic compatibility	Compliant ref: EN 61326 (1997), EN 61010-1 (1993)
Low voltage directive	Compliant ref: EN60950.

## INPUTS

Sensor	
Type A	4-20mA - with signal calibration feature.
Accuracy	Resolution: 16 bit.. Error < 0.01mA / ±0.05% FS. Low level cut-off programmable.
Span	0.00001 to 199,999 units with variable decimal position.
Offset	-99,999 to +199,999 units
Update time	Four times a second.
Voltage drop	max. 2.6 Volt.
Relationship	Linear and square root calculation.

## OPERATIONAL

Operator functions	
Displayed functions	<ul style="list-style-type: none"> <li>top line: main display value.</li> <li>bottom line: measuring unit and messages.</li> <li>bottom line: actual percentage in relation to it's measuring range (can be enabled / disabled).</li> <li>piegraph: 10 segment display related to the input signal (can be enabled / disabled).</li> <li>actual sensor input value in mA (can be enabled / disabled).</li> <li>displayed value at 0% of the input signal (can be enabled / disabled).</li> <li>displayed value at 100% of the input signal (can be enabled / disabled).</li> </ul>

Main display value	
Digits	5 ½ digits (height: 26mm / 1").
Units	mL - L - M3 - nM3 - mg - g - kg - ton - gal - sgal - ical - lb - bbl - cf - scf - p - rev - °C - °F - °K - % - m - mm - cm - mtr - inch - ft - psi - mbar - bar - barg - mmwk - mmwc - cmwk - cmwc - mwk - mwc - inwc - ftwc - Ph - mV - no unit.
Time unit	sec - min - hour - day - no unit
Decimals	0 – 1 – 2 – 3 – 4 or 5.

Piegraph	
Digits	10 segments.
Relation	to the minimum and maximum input signal (0-100%).

## APPENDIX B: PROBLEM SOLVING

In this appendix, several problems are included that can occur when the F090-A-PL is going to be installed or while it is in operation.

### Display is "0 / zero" while a higher signal is available:

Check:

- SETUP 14: is the span correct?
- SETUP 15: is the offset value correct?
- SETUP 16: is the direction correct?
- SETUP 33/34: is the sensor input signal correctly calibrated?

### The pass code is unknown:

If the pass code is not 1234, there is only one possibility left: call your supplier.

### ALARM

When the alarm flag starts to blink an internal alarm condition has occurred. Press the "select button" several times to display the 5-digit error code. The codes are:

0001: irrecoverable display-data error: data on the display might be corrupted.

0002: irrecoverable data-storage error: the programming cycle might have gone wrong: check programmed values.

0003: error 1 and error 2 occurred simultaneously

The alarm condition will almost certainly be handled internally and if all mentioned values still appear correct, no intervention by the operator is needed. If the alarm occurs more often or stays active for a longer time, please contact your supplier.

## INDEX OF THIS MANUAL

accumulated Total	7	intrinsic safety	19
actual settings	28	Intrinsic safety	19
backlight	18	IP classification	15
color	12	keys	6
density	12	loop powered	18
bargraph	12	main-function	9
battery life time	12	maintenance	23
Battery replacement	22	manual version	3
calibrate	13	model	14
Clear Total	7	Operator level	7
Configuration	8	pass code	14, 26
contents	4	Piegraph	12
dimensions	16	problem solving	26
display		rate/Total	7
function	12	repair	23
filter	13	safety instructions	2
flowrate		sensor	13
decimals	11, 12	serial number	14
measuring unit	11	SETUP-level	8
Span	12	software version	3
time unit	11	subfunction	9
functional description	5	tagnumber	14
hardware version	3	technical specification	24
input loop powered	18	terminal connectors	18
Installation	15	version software	14

## LIST OF FIGURES IN THIS MANUAL

Fig. 1: Application example of the F090-A-PL.....	5
Fig. 2: Control Panel.....	6
Fig. 3: Example of display information during process. ....	7
Fig. 4: Dimensions Aluminum enclosures. ....	16
Fig. 5: Dimensions GRP enclosures. ....	17
Fig. 6: Overview of terminal connectors standard configuration F090-A-PL and options.....	18
Fig. 7: Example serial number. ....	19
Fig. 8: Label information Intrinsically Safe application. ....	20
Fig. 9: Overview terminal connectors XI - Intrinsically Safe applications.....	20
Fig. 10: Configuration example Intrinsically Safe. ....	21
Fig. 11: Battery replacement instructions Intrinsically Safe Battery. ....	22

## LIST OF CONFIGURATION SETTINGS

SETTING	DEFAULT	DATE:	DATE:
<b>1 - DISPLAY</b>	Enter your settings here		
11 unit	L		
12 time unit	Sec		
13 decimals	00000		
14 offset	0 L		
15 span	1600 L		
16 direction	normal		
17 current	off		
18 percentage	off		
19 bargraph	on		
<b>2 - BACKLIGHT</b>			
21 backlight	off		
22 brightness	5		
<b>3 - SENSOR</b>			
31 formula	interpol		
32 filter	01 (off)		
33 calibrat. low - 4mA	default		
34 calibrat. high - 20mA	default		
<b>4 - OTHERS</b>			
41 model	F090-A	F090-A	F090-A
42 software version	03.____.____	03.____.____	03.____.____
43 serial number	-----	-----	-----
44 pass code	0000		
45 tagnumber	0000000		

