

LEVEL MONITOR

WITH ONE HIGH / LOW ALARM OUTPUT.



Features

- Displays level, height and percentage filled.
- Two alarm values can be entered: low and high level alarm.
- Large 17mm (0.67") digits.
- Selectable on-screen engineering units; volumetric or mass.
- Operational temperature -40°C up to +80°C (-40°F up to 176°F).
- Red flashing LED backlight in case of a level alarm.
- Very compact design for panel mount, wall mount or field mount applications.
- Rugged aluminum field mount enclosure IP67/NEMA4X.
- Intrinsically Safe - ATEX, IECEx, FM and CSA approval for gas and dust applications.
- Explosion/flame proof Ex II 2 GD EEx d IIB T5.
- Loop or battery powered, 8 - 24V AC/DC or 115 - 230V AC power supply.
- Sensor supply 8.2 / 12 / 24V DC.

Signal output

- One free configurable alarm output.

Signal input

Level

- (0)4 - 20mA.
- 0 - 10V DC.
- Reed chain resistance.

Applications

- Level measurement where continuous level monitoring is important.
Alternative basic models: F070 or more advanced F077 and F173.

General information

Introduction

The F073 is a versatile level monitor with continuous level monitoring feature. It offers the facility to set one low level and one high level alarm value. If desired, an ignore function can be set up to allow for an incorrect level for a certain period of time. A wide selection of options further enhances the capabilities of this model, including Intrinsic Safety.

Display

The display has large 17mm (0.67") and 8mm (0.31") digits which can be set to show level, height or percentage and alarm values. As the F073 has been designed for field mounted applications, a smart display update function has been incorporated. Related to the lower temperatures, the update frequency of the LCD is tuned automatically to achieve a readable display even at -40°C / -40°F.

Backlight

The tri-color backlight in combination with the F073 offers a unique feature: in case of a level alarm, the backlight can be set to be red or flashing red / green. The background color can be set to green or amber and the intensity can be adjusted from the keyboard. The display is a transfective type, which means that a high contrast reading is guaranteed in full sunlight as well as during the night. This backlight option is also available Intrinsic Safe.

Configuration

All configuration settings are accessed via a simple operator menu which can be pass-code protected. Each setting is clearly indicated with an alphanumerical description, which avoids confusing abbreviations. All settings are safely stored in EEPROM memory in the event of sudden power failure.

Alarm output

One alarm output is available to transmit the level alarm. It can be set to switched for a low, high or both alarms! The output signal can be a passive NPN, active PNP or an isolated electro-mechanical relay.

Signal input

The F073 does accept (0)4 - 20mA, 0 - 10V and reed chain level input signals from any type of level measurement device. Also a 4 - 20mA input loop powered model is available.

Hazardous area

For hazardous area applications, this model has been ATEX, IECEx, FM and CSA certified Intrinsically Safe for gas and dust applications, with an allowed operational temperature of -40°C to +70°C (-40°F to +158°F). A flame proof enclosure with ATEX certification offers the rating $\text{Ex II 2 GD EEx d IIB T5}$.

Enclosures

Various types of enclosures can be selected, all ATEX, IECEx, FM and CSA approved. As standard the F073 is supplied in an GRP panel mount enclosure, which can be converted to an IP67 / NEMA 4X GRP field mount enclosure by the addition of a back case. Most popular is our aluminum field mount enclosure with IP67 / NEMA 4X rating. Both European or U.S. cable gland entry threads are available.

Overview application F073

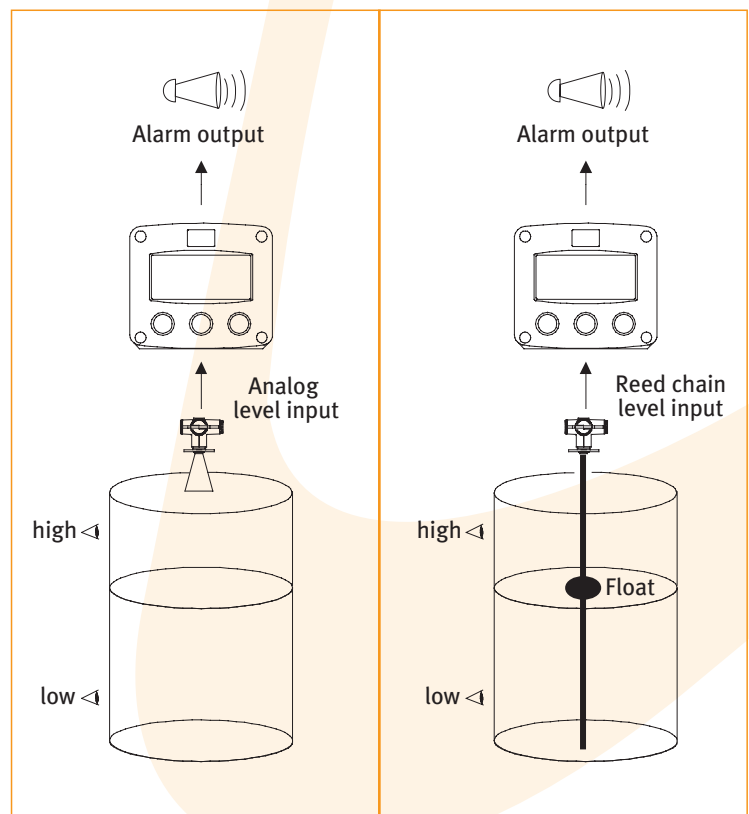

Dimensions enclosures Aluminum & GRP panel mount enclosure

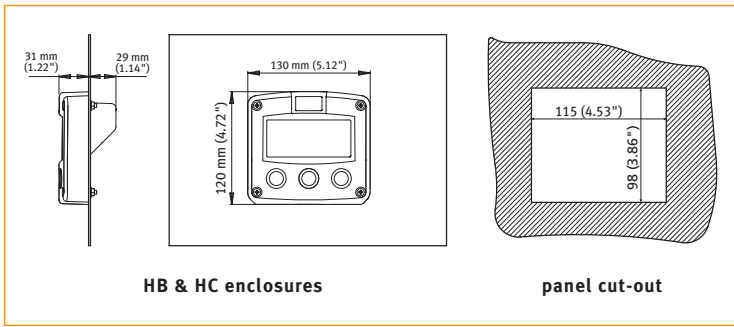

Aluminum & GRP field / wall mount enclosures

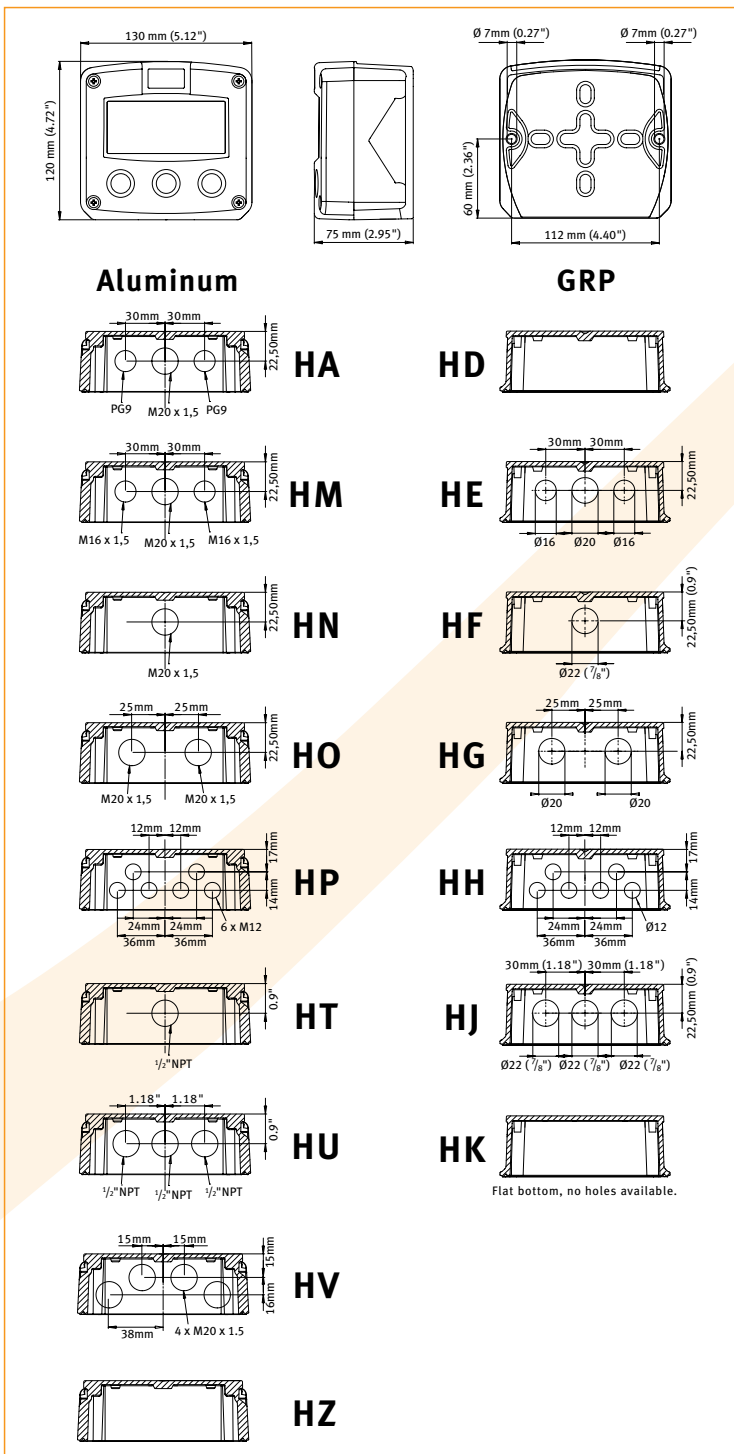

Terminal connections power supply PB/PC - PD - PL - PX

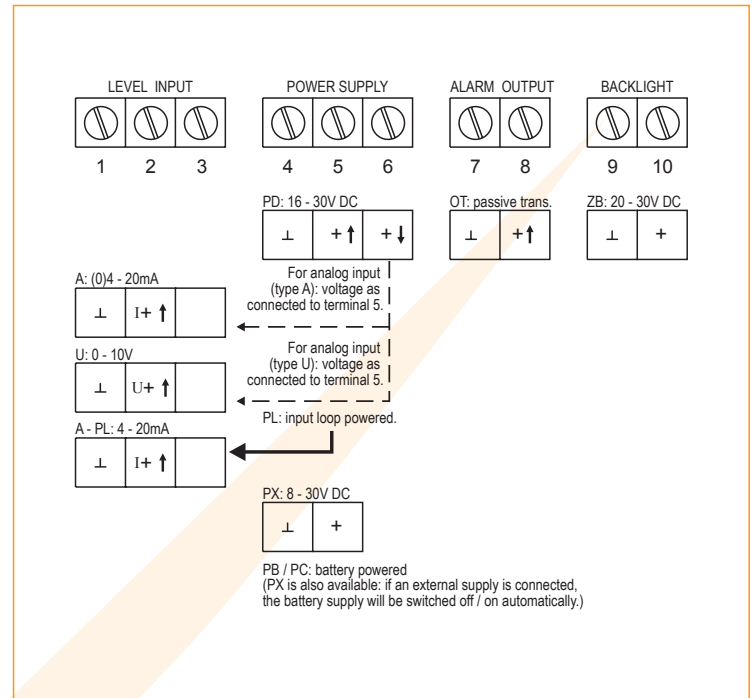

Terminal connections power supply PF - PM

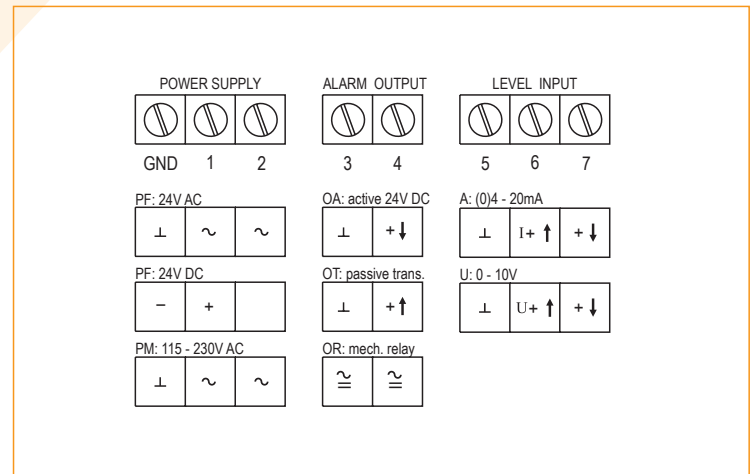

Terminal connections Reed chain level sensor

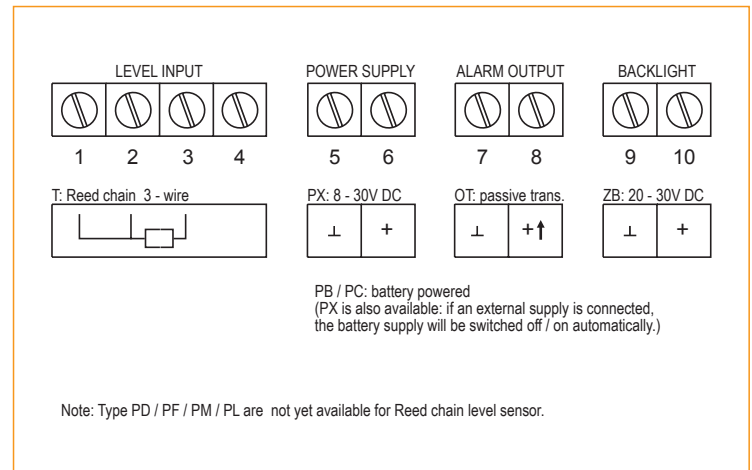

Typical wiring diagram Fo73-T-OT-PB-(PX)

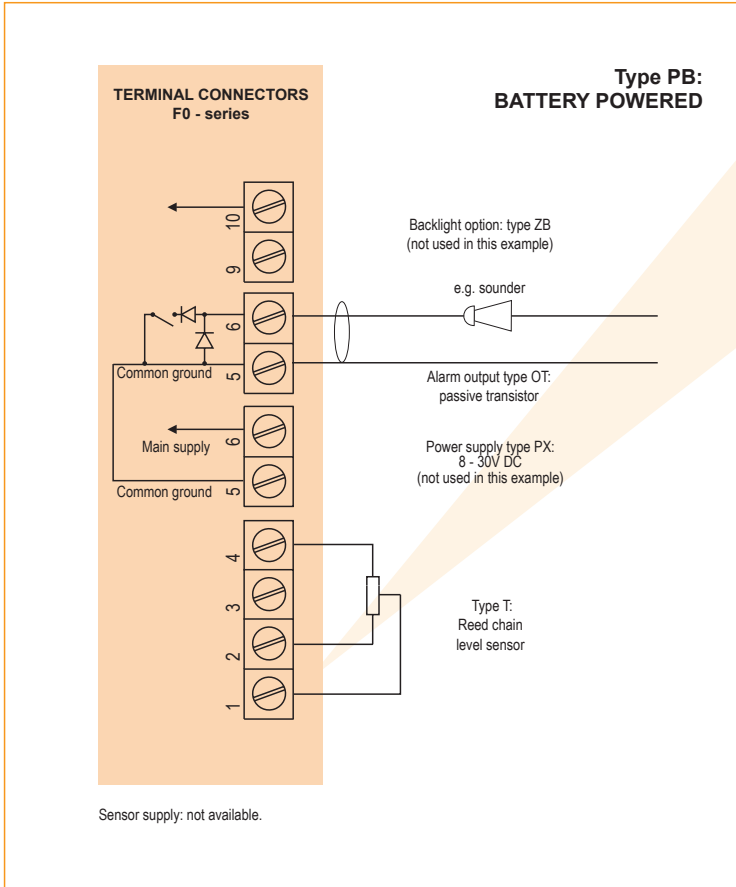

Typical wiring diagram Fo73-A-OT-PX-ZB

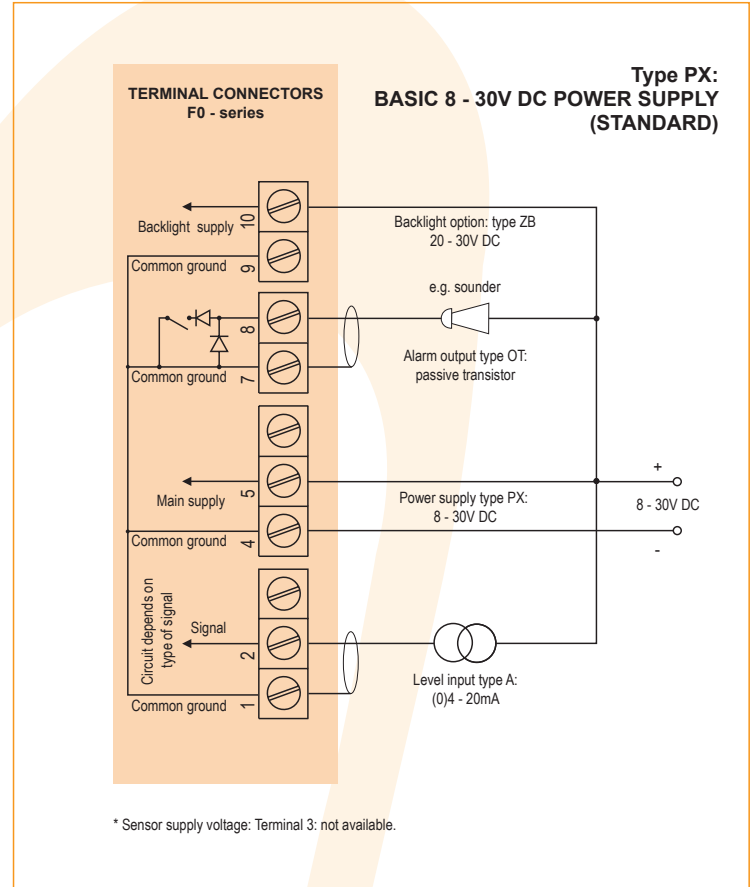

Typical wiring diagram Fo73-A-(OT)-PL-ZB

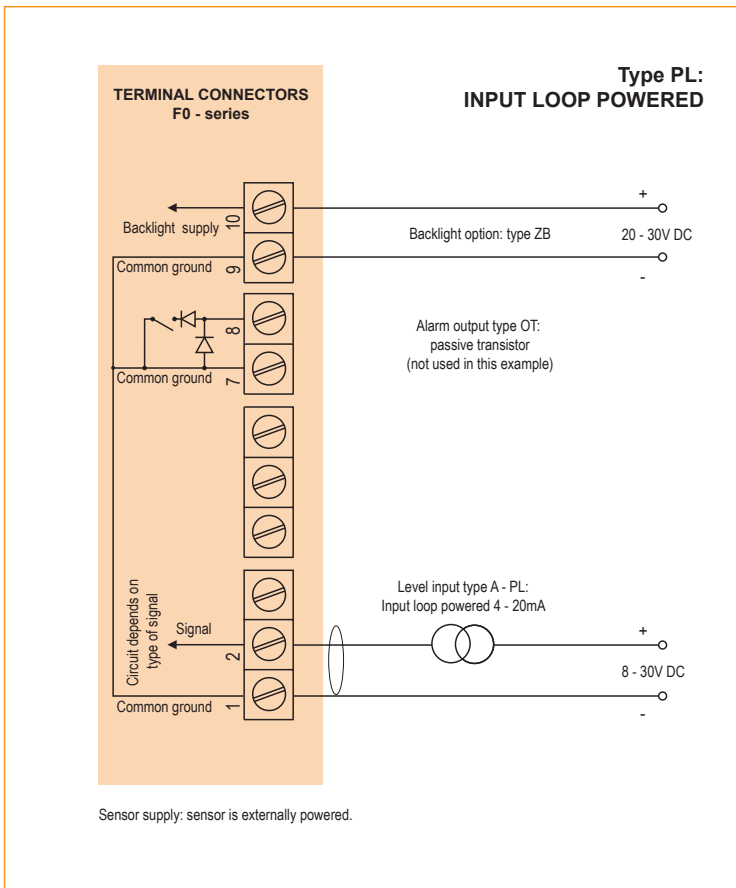

Typical wiring diagram Fo73-A-OT-PD-ZB

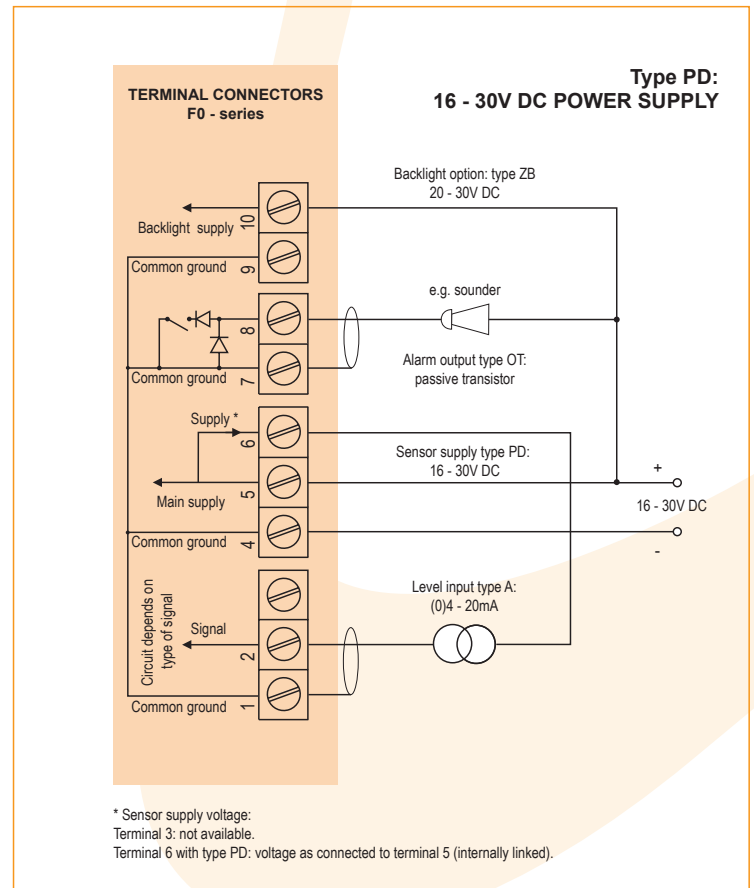

Typical wiring diagram F073-A-OA-PF-ZB

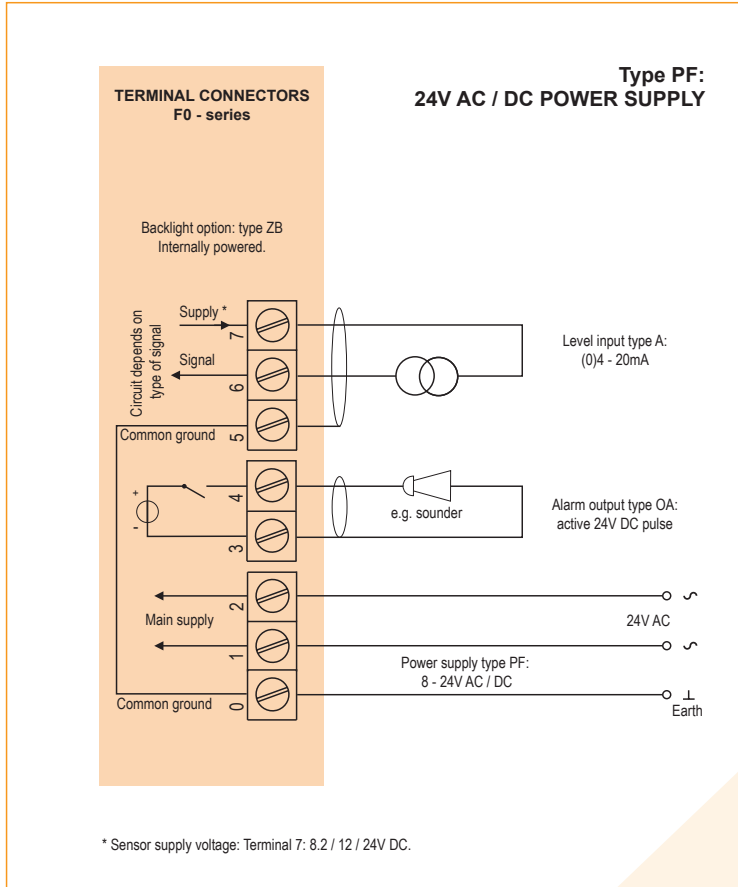

Typical wiring diagram F073-A-OT-PF-ZB

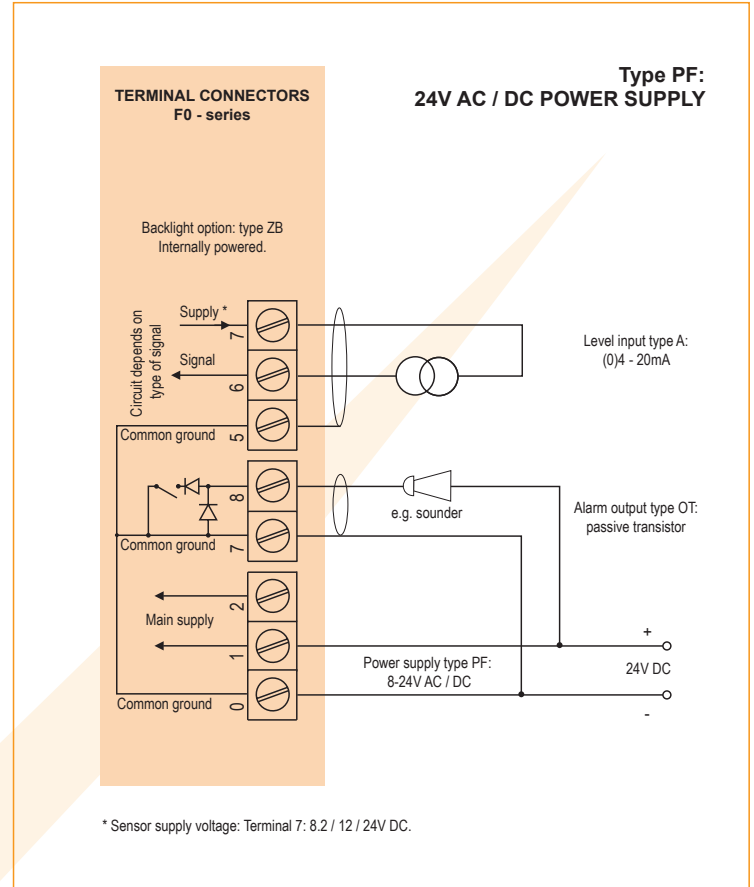

Typical wiring diagram F073-A-OA-PM-ZB

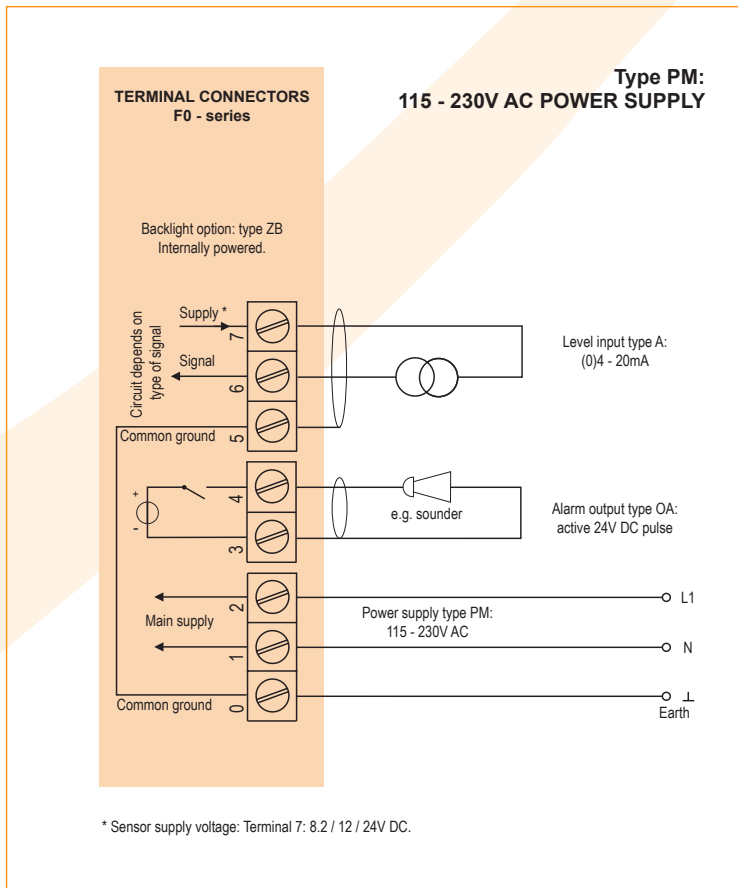

Typical wiring diagram F073-A-OR-PM-ZB

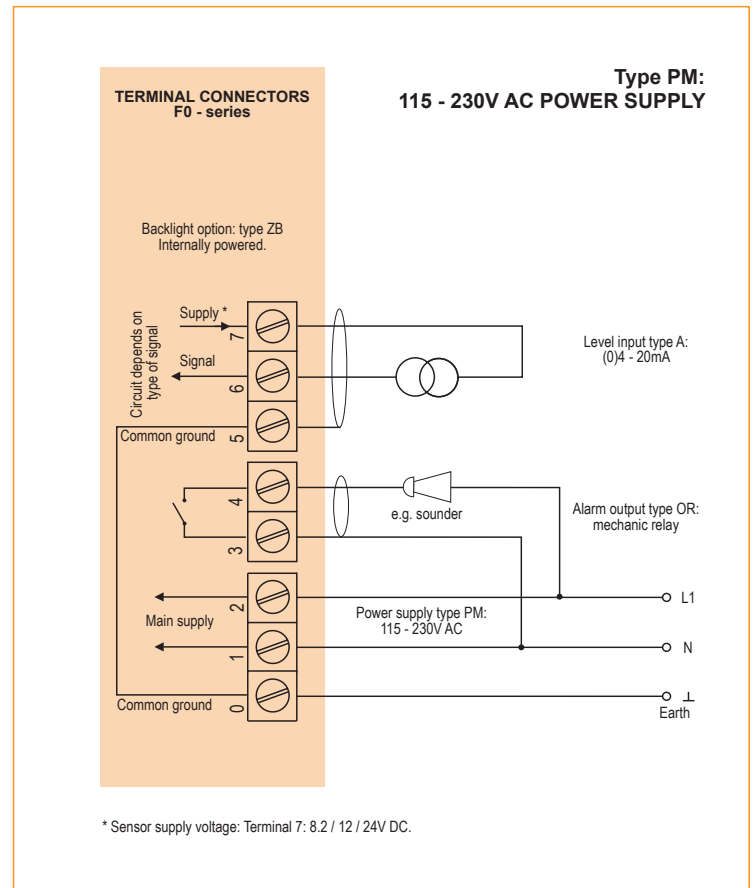

Hazardous area applications

The F073-XI has been certified according ATEX and IECEx by KEMA and according CSA c-us and FM for use in Intrinsically Safe applications with an ambient temperature of -40°C to +70°C (-40°F to +158°F).

- The ATEX markings for gas and dust applications are:

II 1 G Ex ia IIC T4
II 1 D Ex iaD 20 IP 65/67 T 100 [C].

- The IECEx markings for gas and dust applications are: **Ga Ex ia IIC T4 and Ex iaD 20 IP 65/67 T100 [C].**
- The CSA c-us markings are: **Class I/II/III, Division 1, Groups A, B, C, D, E, F, G, Temperature class T4 and Class I, Zone 0, AEx ia IIC T4.**
- The FM markings are: **Class I/II/III, Division 1, Groups A, B, C, D, E, F, G, Temperature class T4 and Class I, Zone 0, AEx ia IIC T4.**

It is allowed to connect up to three I.S. power supplies to power the unit, sensor and backlight. Consult the certificate for the maximum

input and output values of the circuits. The F073-PD-XI offers the input voltage to power an analog sensor. An ATEX approved flame proof enclosure with rating **Ex II 2 GD EEx d IIB T5** is available as well. Please contact your supplier for further details.

Certificate of conformity KEMA 05ATEX1168 X
• IECEx KEM 08.0006X • CSA.08.2059461 X

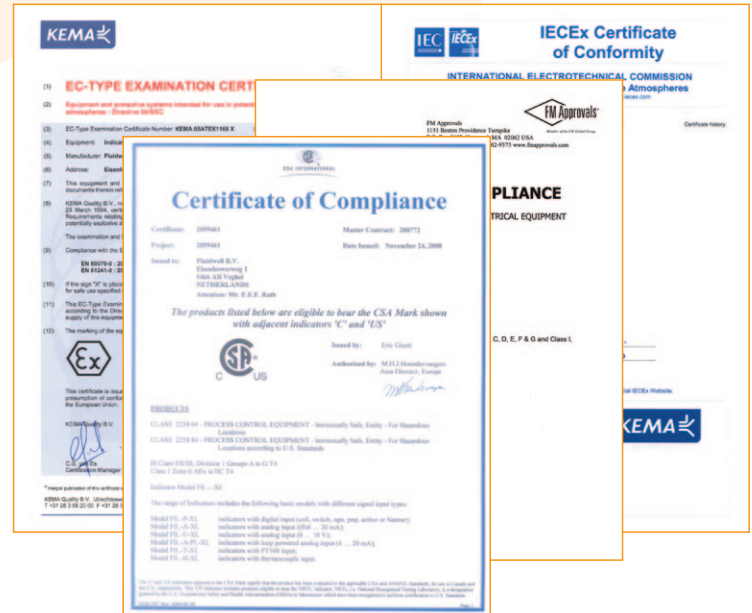

Configuration example IIA - IIB and IIC - F073-T-OT-PX-XI-ZB - Basic power supply 8 - 30V DC

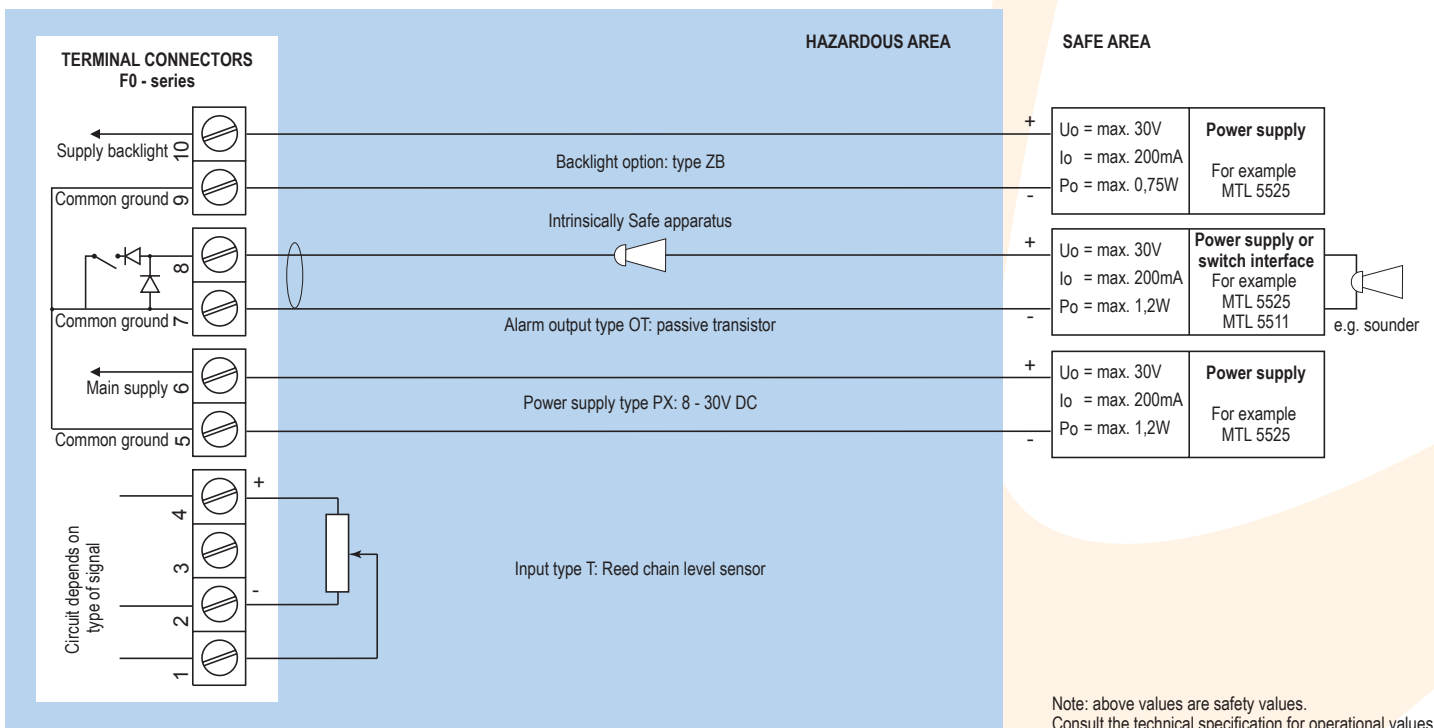

Please note: type PX may be used in combination with the battery (type PC). PX will power the unit; the battery will be disabled automatically till power is disconnected.

Configuration example IIA - IIB and IIC - F073-A-OT-PD-XI-ZB - Power supply 16 - 30V DC

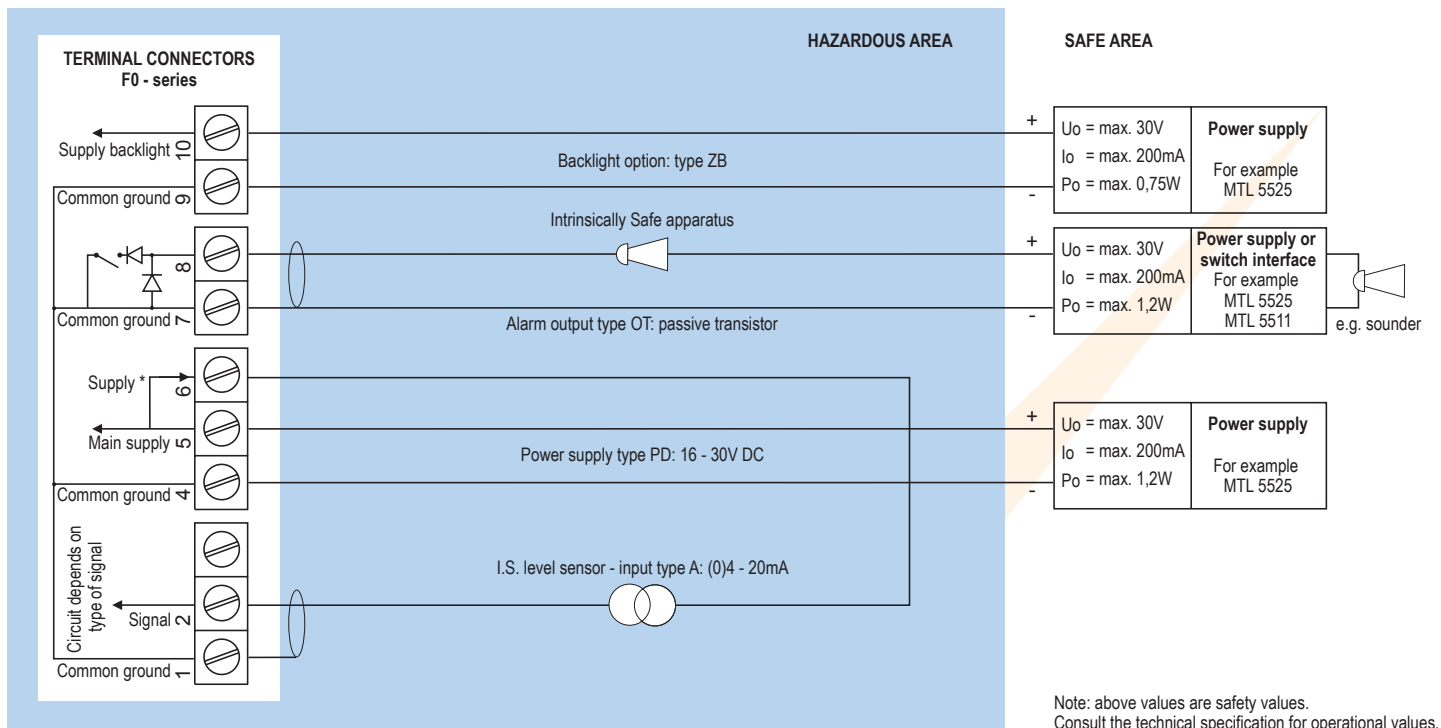

* Sensor supply voltage for analog level sensor type A / U: Terminal 6: as input voltage terminal 5 (internally linked).
Please note: type PD may be used in combination with the battery (type PC). PD will power the unit; the battery will be disabled automatically till power is disconnected.

Configuration example IIA - IIB and IIC - F073-A-OT-PL-XI-ZB - Input loop powered

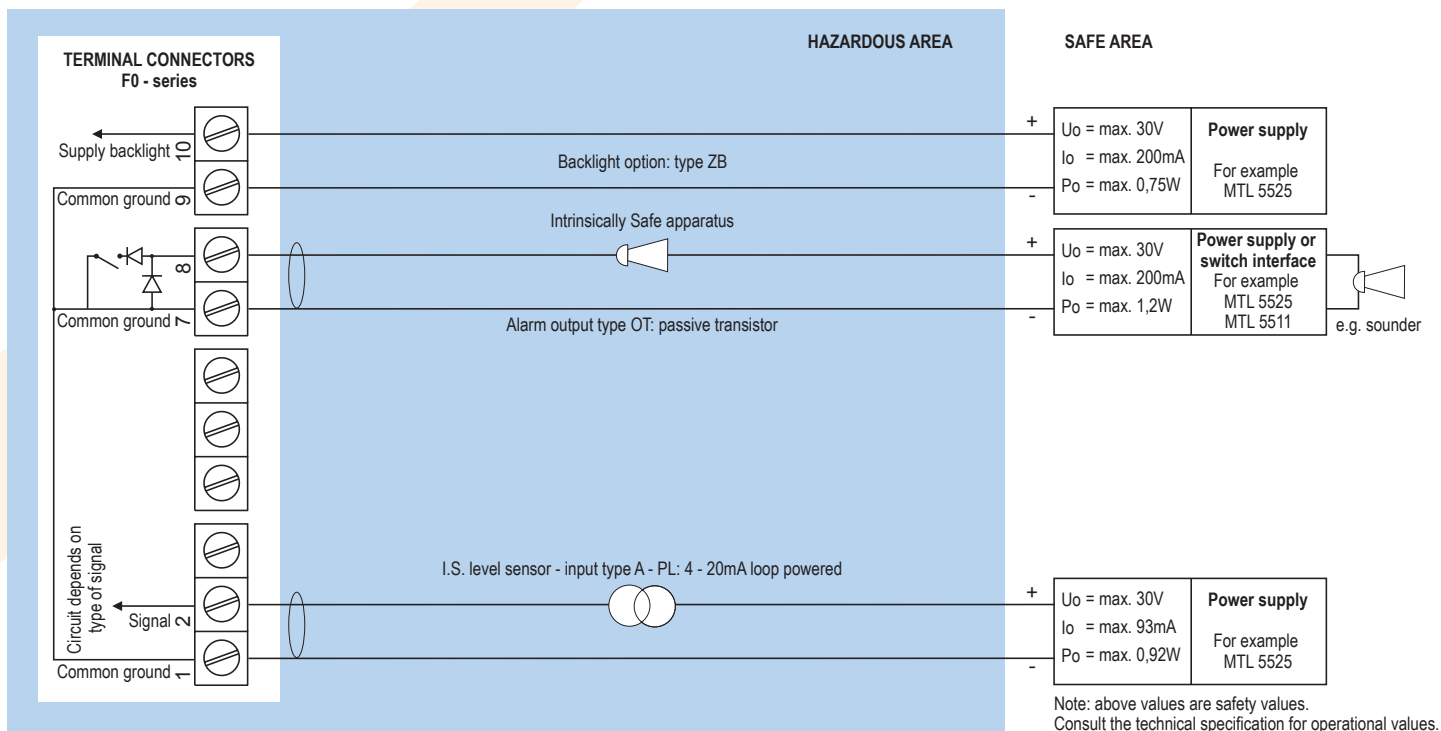

Sensor supply is not available: unit is input loop powered (type PL).
Please note: type PL may be used in combination with the battery (type PC). PL will power the unit; the battery will be disabled automatically till power is disconnected.

Technical specification

General

Display

Type	High intensity reflective numeric and alphanumeric LCD, UV-resistant.
Dimensions	90 x 40mm (3.5" x 1.6").
Digits	Seven 17mm (0.67") and eleven 8mm (0.31") digits. Various symbols and measuring units.
Refresh rate	User definable: 8 times/sec. - 1 time/30 secs - off.
Option ZB	Transflective LCD with tri-color LED-backlight; green / amber. Red (flashing) backlight during alarm conditions. Intensity, color and alarm response selected through the keyboard. Good readings in full sunlight and darkness. Also available Intrinsically Safe.

Operating temperature

Standard unit	-40°C to +80°C (-40°F to +176°F).
Intrinsically Safe	-40°C to +70°C (-40°F to +158°F).

Power requirements

Type PB	Long life Lithium battery - life-time depends upon settings and configuration - up to 5 years.
Type PC	Intrinsically Safe long life lithium battery - life-time depends upon settings and configuration - up to 5 years.
Type PD	16 - 30V DC. Power consumption max. 1 Watt.
Type PF	24V AC / DC ± 10%. Power consumption max. 15 Watt.
Type PL	Input loop powered from sensor signal 4 - 20mA (type A).
Type PM	115 - 230V AC ± 10%. Power consumption max. 15 Watt.
Type PX	8 - 30V DC. Power consumption max. 0.3 Watt.
Type ZB	20 - 30V DC. Power consumption max. 1 Watt. With type PF / PM: internally powered.
Note PB/PF/PM	Not available Intrinsically Safe.
Note PF/PM	The total consumption of the sensor, active output type OA and backlight type ZB may not exceed 400mA @ 24V DC.
Note	For Intrinsically Safe applications, consult the safety values in the certificate.

Sensor excitation

Type PB/PC/PX	Only suitable for Reed chain sensors.
Type PD	The sensor supply voltage will be according to power supply voltage (as connected to terminal 5).
Type PF / PM	8.2 / 12 / 24V DC - max. 400mA @ 24V DC.
Note	Sensor supply is not needed for Reed chain sensors.

Terminal connections

Type	Removable plug-in terminal strip. Wire max. 1.5mm ² and 2.5mm ² .
------	---

Data protection

Type	EEPROM backup of all settings. Data retention at least 10 years.
Pass-code	Configuration settings can be pass-code protected.

Casing

General

Window	Polycarbonate window.
Sealing	Silicone.
Control keys	Three industrial micro-switch keys. UV-resistant silicone keypad.

Aluminum wall / field mount enclosures

General	Die-cast aluminum wall/field mount enclosure IP67 / NEMA 4X with 2-component UV-resistant coating.
Dimensions	130 x 120 x 75mm (5.12" x 4.72" x 2.95") - W x H x D.
Weight	1100 gr.
Type HA	Cable entry: 2 x PG9 and 1 x M20.
Type HM	Cable entry: 2 x M16 and 1 x M20.
Type HN	Cable entry: 1 x M20.
Type HO	Cable entry: 2 x M20.
Type HP	Cable entry: 6 x M12.
Type HT	Cable entry: 1 x 1/2" NPT.
Type HU	Cable entry: 3 x 1/2" NPT.
Type HV	Cable entry: 4 x M20.
Type HZ	Cable entry: no holes.

GRP wall / field mount enclosures

General	GRP wall/field mount enclosure IP67 / NEMA 4X, UV-resistant and flame retardant.
Dimensions	130 x 120 x 75mm (5.12" x 4.72" x 2.95") - W x H x D.
Weight	600 gr.
Type HD	Cable entry: no holes.
Type HE	Cable entry: 2 x Ø 16mm and 1 x Ø 20mm.
Type HF	Cable entry: 1 x Ø 22mm (7/8").
Type HG	Cable entry: 2 x Ø 20mm.
Type HH	Cable entry: 6 x Ø 12mm.
Type HJ	Cable entry: 3 x Ø 22mm (7/8").
Type HK	Flat bottom, cable entry: no holes.

Panel mount enclosures

Dimensions	130 x 120 x 60mm (5.12" x 4.72" x 2.36") - W x H x D.
Panel cut-out	115 x 98mm (4.53" x 3.86") L x H.
Type HB	Die-cast aluminum panel mount enclosure IP65 / NEMA 4X.
Weight	600 gr.
Type HC	GRP panel mount enclosure IP65 / NEMA 4X, UV-resistant and flame retardant.
Weight	450 gr.

ABS wall / field mount enclosures



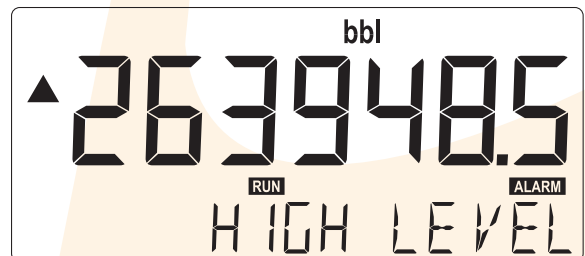

General	Silicone free ABS wall/field mount enclosure IP65 with EPDM and PE sealings. UV-resistant polyester keypad (old HD enclosure).
Dimensions	130 x 114 x 71mm (5.1" x 4.5" x 2.8") - W x H x D.
Weight	450 gr.
Type HS	Cable entry: no holes.

Display example - 90 x 40mm (3.5" x 1.6")



Hazardous area

Intrinsically Safe

ATEX certification	 II 1 G Ex ia IIC T4. II 1 D Ex iaD 20 IP 65 / 67 T 100 °C.
IECEX certification	 Ga Ex ia IIC T4. Ex iaD 20 IP 65 / 67 T 100 °C.
CSA c-us certification	 Intrinsically Safe for Class I/II/III, Div. 1, Groups A, B, C, D, E, F, G, Temp. class T4 and Class I, Zone o, AEx ia IIC T4.
FM certification	 Intrinsically Safe for Class I/II/III, Div. 1, Groups A, B, C, D, E, F, G, Temp. class T4 and Class I, Zone o, AEx ia IIC T4.
Ambient Ta	-40°C to +70°C (-40°F to +158°F).

Explosion proof

ATEX certification	 II 2 GD EEx d IIB T5.
Type XF	Dimensions of enclosure: 300 x 250 x 200mm (11.8" x 9.9" x 7.9") L x H x D.
Weight	Appr. 15kg.

Environment

Electromagnetic compatibility	Compliant ref: EN 61326 (1997), EN 61010-1 (1993).
-------------------------------	--

Signal input

Level sensor

Span	0.001 / 999,999 with variable decimal position.
Offset	-999,999 / +999,999 units.
Relationship	Linear and square root calculation.
Type A	(0)4 - 20mA. Analog input signal can be scaled to any desired range within 0 - 20mA.
Type U	0 - 10V DC. Analog input signal can be scaled to any desired range within 0 - 10V DC.
Voltage drop	Type A: max. 2V DC @ 20mA.
Voltage drop	Type A - PL (loop powered): max. 2.6V DC @ 20mA.
Accuracy	Resolution: 16 bit. Error < 0.01mA / ± 0.05% FS. Low level cut-off programmable.
Update time	Four times per second.
Load impedance	Type U: 3kΩ.
Type T	3-wire Reed chain sensor (req. PB, PC or PX).
Update time	Once per second.
Note	For signal type A and U: external power to sensor is required; e.g. type PD.

Signal output

Alarm output

Function	User defined: low, high or both alarms output.
Type OA	One active 24V DC transistor output (PNP); load max. 400mA (requires PF or PM).
Type OR	One electro-mechanical relay output - isolated; max. switch power 230V AC (N.O.) - 0.5A (requires PF or PM).
Type OT	One passive transistor output (NPN) - not isolated. Max. 50V DC - 300mA per output.

Operational

Operator functions

Displayed functions	<ul style="list-style-type: none"> • Level. • Height or percentage (or no indication). • Low alarm value. • High alarm value. • Alarm values can be set (or only displayed).
---------------------	---

Level

Digits	7 digits.
Units	L, m³, GAL, USGAL, kg, lb, bbl, no unit.
Decimals	0 - 1 - 2 or 3.

Height

Digits	6 digits.
Units	mm, cm, m, mtr, inch, ft, mmwk, mmwc, cmwk, cmwc, mwk, mwc, inwc, ftwc, mbar, bar, psi, no unit.
Decimals	0 - 1 or 2.

Percentage

Digits	3 digits.
Decimals	1.

Alarm values

Digits	7 digits.
Units	According to the settings for level.
Decimals	According to the settings for level.
Time units	According to the settings for level.
Type of alarm	Low and high level alarm. Includes alarm delay time and configurable alarm output.

Accessories

Mounting accessories

ACFo2	Stainless steel wall mounting kit.
ACFo5	Stainless steel pipe mounting kit (worm gear clamps not included).
ACFo6	Two stainless steel worm gear clamps Ø 44 - 56mm.
ACFo7	Two stainless steel worm gear clamps Ø 58 - 75mm.
ACFo8	Two stainless steel worm gear clamps Ø 77 - 95mm.
ACFo9	Two stainless steel worm gear clamps Ø 106 - 138mm.
ACF10	Customized Grevopal tagplates for ACFo2 and ACFo5, including stainless steel screws. Dimension: 95mm x 12.5mm (3.75" x 0.50").

Cable gland accessories

ACF20	For HA enclosure, includes O-rings.
ACF25	For HE enclosure, includes locknuts and O-rings.
ACF26	For HF enclosure, includes locknuts and O-rings.
ACF27	For HG enclosure, includes locknuts and O-rings.
ACF28	For HH enclosure, includes locknuts and O-rings.
ACF29	For HJ enclosure, includes locknuts and O-rings.
ACF32	For HM enclosure, includes O-rings.
ACF33	For HN enclosure, includes O-rings.
ACF34	For HO enclosure, includes O-rings.
ACF35	For HP enclosure, includes O-rings.
ACF39	For HT enclosure, includes O-rings.
ACF40	For HU enclosure, includes O-rings.

Blind plug accessories

ACF50	For HA enclosure, includes O-rings.
ACF55	For HE enclosure, includes locknuts and O-rings.
ACF56	For HF enclosure, includes locknuts and O-rings.
ACF57	For HG enclosure, includes locknuts and O-rings.
ACF58	For HH enclosure, includes locknuts and O-rings.
ACF59	For HJ enclosure, includes locknuts and O-rings.
ACF62	For HM enclosure, includes O-rings.
ACF63	For HN enclosure, includes O-rings.
ACF64	For HO enclosure, includes O-rings.
ACF65	For HP enclosure, includes O-rings.
ACF69	For HT enclosure, includes O-rings.
ACF70	For HU enclosure, includes O-rings.

Ordering information

Standard configuration: F073-A-HC-OT-PX-XX-ZX.

ordering information:	F073	-	-H	-O	-P	-X	-Z
Level sensor input signal							
A	⊗	(o)4 - 20mA input.					
T	⊗	Reed chain resistance input - requires PB, PC or PX.					
U	⊗	0 - 10V DC input.					
Panel mount enclosures - IP65 / NEMA4X							
HB	⊗	Aluminum enclosure.					
HC	⊗	GRP enclosure.					
GRP field / wall mount enclosures - IP67 / NEMA4X							
HD	⊗	Cable entry: no holes.					
HE	⊗	Cable entry: 2 x Ø 16mm & 1 x Ø 20mm.					
HF	⊗	Cable entry: 1 x Ø 22mm (7/8").					
HG	⊗	Cable entry: 2 x Ø 20mm.					
HH	⊗	Cable entry: 6 x Ø 12mm.					
HJ	⊗	Cable entry: 3 x Ø 22mm (7/8").					
HK	⊗	Flat bottom, cable entry: no holes.					
Aluminum field / wall mount enclosures - IP67 / NEMA4X							
HA	⊗	Cable entry: 2 x PG9 + 1 x M20.					
HM	⊗	Cable entry: 2 x M16 + 1 x M20.					
HN	⊗	Cable entry: 1 x M20.					
HO	⊗	Cable entry: 2 x M20.					
HP	⊗	Cable entry: 6 x M12.					
HT	⊗	Cable entry: 1 x 1/2" NPT.					
HU	⊗	Cable entry: 3 x 1/2" NPT.					
HV	⊗	Cable entry: 4 x M20.					
HZ	⊗	Cable entry: no holes.					
ABS field / wall mount enclosures - IP65							
HS	⊗	Silicone free ABS field enclosure – Cable entry: no holes (old HD enclosure).					
Output							
OA		One active transistor output - requires PF or PM.					
OR		One mechanical relay output - requires PF or PM.					
OT	⊗	One passive transistor output - standard configuration.					
Power supply							
PB		Lithium battery powered.					
PC	⊗	Lithium battery powered - Intrinsically Safe.					
PD	⊗	16 - 30V DC + sensor supply.					
PF		24V AC / DC + sensor supply.					
PL	⊗	Input loop powered from sensor signal 4 - 20mA (type A).					
PM		115 - 230V AC + sensor supply.					
PX	⊗	Basic power supply 8 - 30V DC (no sensor supply).					
Hazardous area							
XI	⊗	Intrinsically Safe, according ATEX, IECEx, CSA c-us and FM.					
XF		EExd enclosure - 3 keys.					
XX		Safe area only.					
Other options							
ZB	⊗	Backlight.					
ZX	⊗	No options.					

The bold marked text contains the standard configuration.

⊗ Available Intrinsically Safe.

Specifications are subject to change without notice.



Fluidwell bv
P.O. Box 6
5460 AA - Veghel - The Netherlands
Tel.: +31 (0)413 343786
Fax.: +31 (0)413 363443
sales@fluidwell.com
Internet: www.fluidwell.com

