

# ***F073-A***

***LEVEL MONITOR***

***WITH HIGH / LOW LEVEL ALARMS***

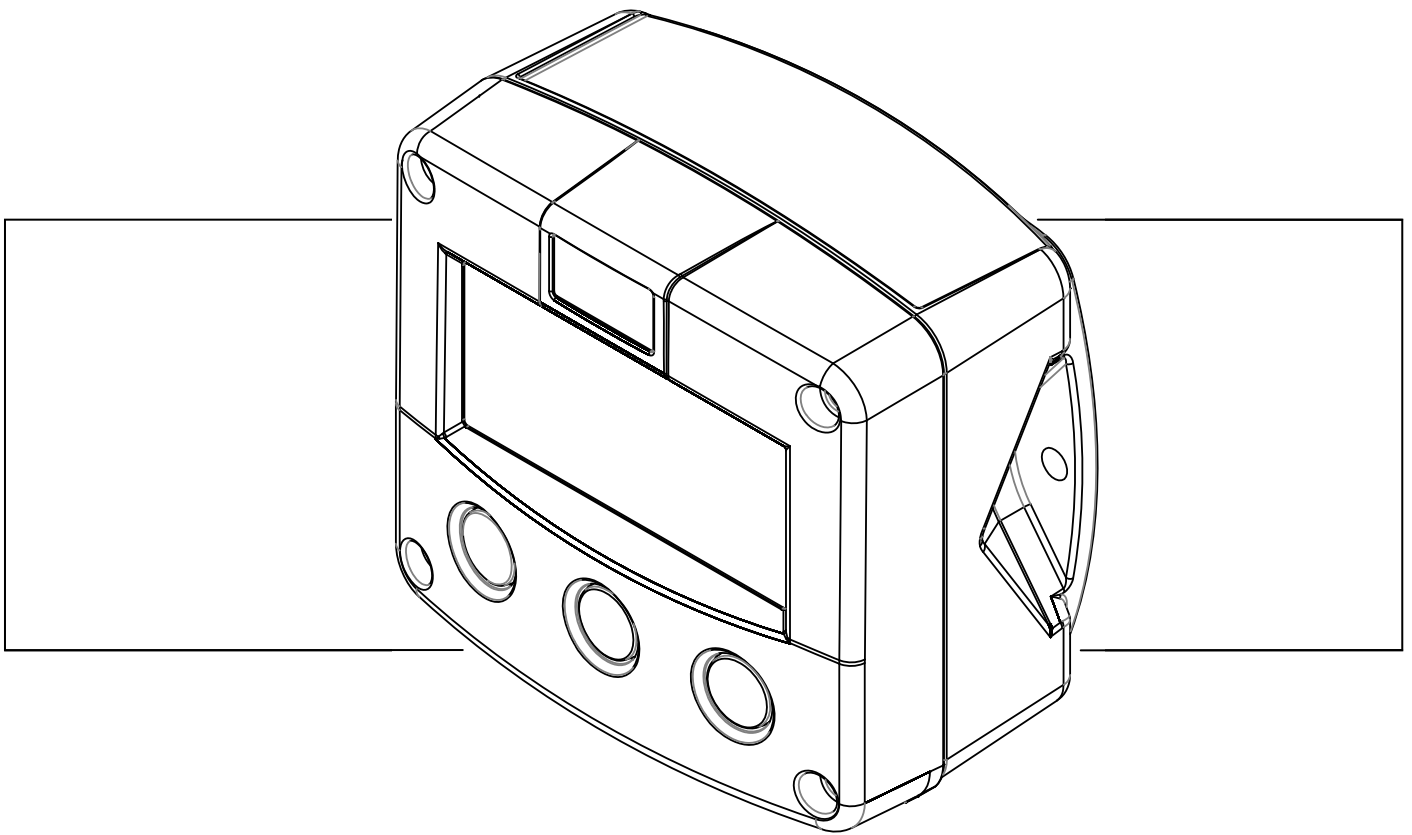

*Signal input sensor: (0)4-20mA.*

*Alarm output: one level alarm.*

*Options: Intrinsically Safe.*



## SAFETY INSTRUCTIONS



- Any responsibility is lapsed if the instructions and procedures as described in this manual are not followed.
- **LIFE SUPPORT APPLICATIONS:** The F073-A is not designed for use in life support appliances, devices, or systems where malfunction of the product can reasonably be expected to result in a personal injury. Customers using or selling these products for use in such applications do so at their own risk and agree to fully indemnify the manufacturer and supplier for any damages resulting from such improper use or sale.
- Electro static discharge does inflict irreparable damage to electronics! Before installing or opening the unit, the installer has to discharge himself by touching a well-grounded object.
- This unit must be installed in accordance with the EMC guidelines (Electro Magnetic Compatibility).
- Do connect a proper grounding to the aluminum casing as indicated if the F073-A has been supplied with the 115-230V AC power-supply type PM. The green / yellow wire between the back-casing and removable terminal-block may never be removed.
- Inherently Safe applications: follow the instructions as mentioned in Chapter 5 and consult "Fluidwell F0...-XI - Documentation for Intrinsic Safety".

## DISPOSAL



- At the end of its life this product should be disposed of according to local regulations regarding waste electronic equipment. If a battery is present in this product it should be disposed of separately. The separate collection and recycling of your waste equipment will help to conserve natural resources and ensure that it is recycled in a manner that protects the environment.

## SAFETY RULES AND PRECAUTIONARY MEASURES

- The manufacturer accepts no responsibility whatsoever if the following safety rules and precautions instructions and the procedures as described in this manual are not followed.
- Modifications of the F073-A implemented without preceding written consent from the manufacturer, will result in the immediate termination of product liability and warranty period.
- Installation, use, maintenance and servicing of this equipment must be carried out by authorized technicians.
- Check the mains voltage and information on the manufacturer's plate before installing the unit.
- Check all connections, settings and technical specifications of the various peripheral devices with the F073-A supplied.
- Open the casing only if all leads are free of potential.
- Never touch the electronic components (ESD sensitivity).
- Never expose the system to heavier conditions than allowed according to the casing classification (see manufacture's plate and chapter 4.2.).
- If the operator detects errors or dangers, or disagrees with the safety precautions taken, then inform the owner or principal responsible.
- The local labor and safety laws and regulations must be adhered to.

## ABOUT THE OPERATION MANUAL

This operation manual is divided into two main sections:

- The daily use of the unit is described in chapter 2 "Operation". These instructions are meant for users.
- The following chapters and appendices are exclusively meant for electricians/technicians. These provide a detailed description of all software settings and hardware installation guidance.

This operation manual describes the standard unit as well as most of the options available. For additional information, please contact your supplier.

**A hazardous situation may occur if the F073-A is not used for the purpose it was designed for or is used incorrectly. Please carefully note the information in this operating manual indicated by the pictograms:**



A "**warning**" indicates actions or procedures which, if not performed correctly, may lead to personal injury, a safety hazard or damage of the F073-A or connected instruments.



Caution !

A "**caution**" indicates actions or procedures which, if not performed correctly, may lead to personal injury or incorrect functioning of the F073-A or connected instruments.



Note !

A "**note**" indicates actions or procedures which, if not performed correctly, may indirectly affect operation or may lead to an instrument response which is not planned.

Hardware version	:	FB03.03.xx
Software version	:	03.03.xx
Manual	:	HF073AEN_v0403_03 Atex_IECEX_CSA_FM
© Copyright 2012	:	Fluidwell bv - The Netherlands.

**Information in this manual is subject to change without prior notice. The manufacturer is not responsible for mistakes in this material or for incidental damage caused as a direct or indirect result of the delivery, performance or use of this material.**

**© All rights reserved. No parts of this publication may be reproduced or used in any form or by any means without written permission of your supplier.**

# CONTENTS MANUAL

Safety instructions .....	2
Disposal .....	2
Safety rules and precautionary measures .....	2
About the operation manual .....	3
Contents manual.....	4
1.1. System description of the F073-A.....	5
2. Operational.....	6
2.1. General .....	6
2.2. Control panel.....	6
2.3. Operator information and functions .....	7
3. Configuration.....	9
3.1. Introduction .....	9
3.2. Programming SETUP-level.....	9
3.2.1. General .....	9
3.2.2. Overview functions SETUP level .....	12
3.2.3. Explanation of SETUP-functions.....	13
1 - Level .....	13
2 - Height .....	14
3 - Alarm .....	15
4 - Display.....	15
5 - Power management .....	16
6 - Sensor .....	17
7 - Others .....	18
4. Installation .....	19
4.1. General directions .....	19
4.2. Installation / surrounding conditions .....	19
4.3. Dimensions- Enclosure .....	20
4.4. Installing the hardware.....	22
4.4.1. Introduction .....	22
4.4.2. Terminal connectors with power supply - <u>type : PB / PD / PL / PX</u> .....	23
4.4.3. Terminal connectors with power supply - <u>type : PF / PM</u> .....	25
5. Intrinsically safe applications.....	28
5.1. General information and instructions:.....	28
5.2. Terminal connectors Intrinsically Safe applications:.....	30
5.3. Configuration examples Intrinsically Safe applications:.....	30
5.4. Battery replacement instructions.....	32
6. Maintenance.....	33
6.1. General directions .....	33
6.2. Repair.....	33
Appendix A: Technical specification .....	34
Appendix B: Problem solving.....	37
Index of this manual.....	38
List of figures in this manual .....	39

## 1. Introduction

### 1.1. SYSTEM DESCRIPTION OF THE F073-A

#### Functions and features

The level monitor model F073-A is a microprocessor driven instrument designed to display level, percentage or the height as well as the monitoring of the level for high / low values.

This product has been designed with a focus on:

- ultra-low power consumption to allow long-life battery powered applications (type PB / PC),
- intrinsic safety for use in hazardous applications (type XI),
- several mounting possibilities with aluminum or GRP enclosures for harsh industrial surroundings,
- alarm transmitting possibilities with one switch output.

#### Sensor input

This manual describes the unit with an analog (0)4-20mA input type from the sensor "-A version". Other versions are available to process a 0-10V sensor signal.

One sensor with a passive or active (0)4-20mA signal output can be connected to the F073-A. To power the sensor, several options are available.

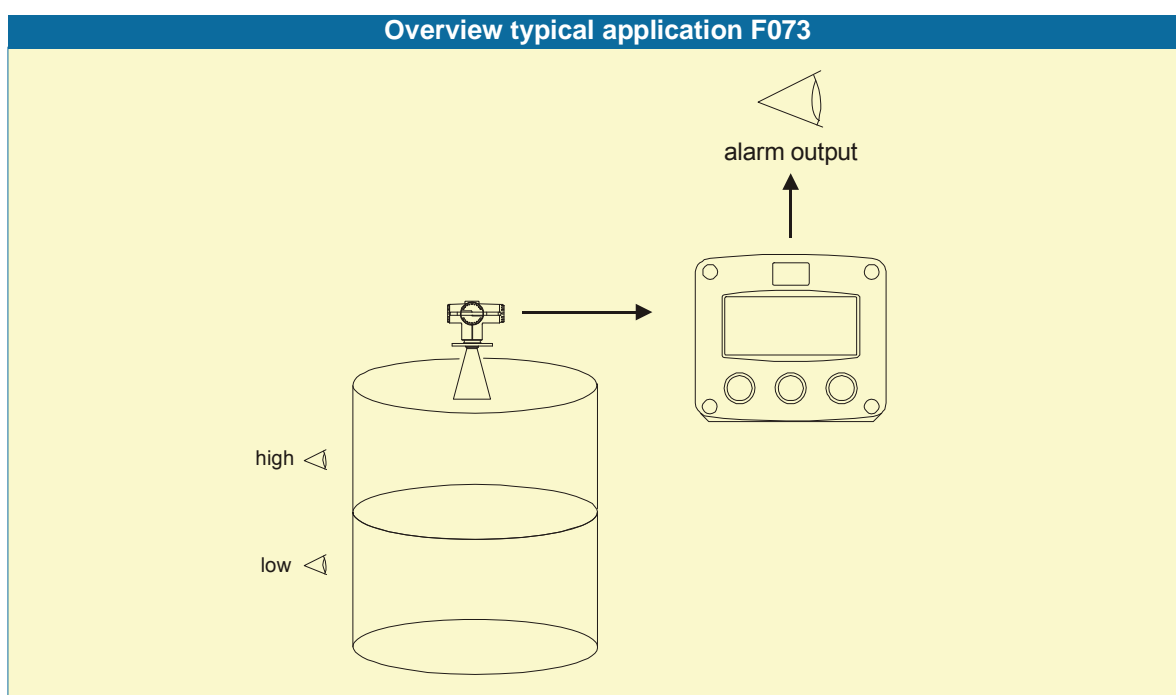

Fig. 1: Typical application for the F073-A.

#### Configuration of the unit

The F073-A has been designed to be implemented in many types of applications. For that reason, a SETUP-level is available to configure your F073-A according to your specific requirements.

It includes several important features, such as Span, measurement units, display options etc. All settings are stored in EEPROM memory and will not be lost in the event of power failure. To extend the battery-life time, please use of the power-management functions as described in chapter 3.2.3.

#### Display information

The unit has a large transreflective LCD with all kinds of symbols and digits to display measuring units, status information, trend-indication and key-word messages.

Level and alarm values are displayed with the large 17mm digits while the smaller 8mm digits can be set to display either the height or percentage filled.

#### Options

The following options are available: intrinsic safety, mechanical relay or active outputs, power- and sensor-supply options, panel-mount, wall-mount and weather-proof enclosures, flame proof enclosure and LED backlight.

## 2. OPERATIONAL

### 2.1. GENERAL



- *The F073-A may only be operated by personnel who are authorized and trained by the operator of the facility. All instructions in this manual are to be observed.*
- *Take careful notice of the " Safety rules, instructions and precautionary measures " in the front of this manual.*

This chapter describes the daily use of the F073-A. This instruction is meant for users / operators.

### 2.2. CONTROL PANEL

The following keys are available:



Fig. 2: Control Panel.

#### Functions of the keys



This key is used to program and save new values or settings.  
It is also used to gain access to SETUP-level; please read chapter 3.



This key is used to SELECT the level alarm values.  
The arrow-key ▲ is used to increase a value after PROG has been pressed or to configure the unit; please read chapter 3.



The arrow-key ► is used to select a digit after PROG has been pressed or to configure the unit; please read chapter 3.

### 2.3. OPERATOR INFORMATION AND FUNCTIONS

In general, the F073-A will always act at Operator level. The information displayed is dependant upon the SETUP-settings. The signal generated by the connected sensor is measured by the F073-A in the background, whichever screen refresh rate setting is chosen. After pressing a key, the display will be updated very quickly during a 30 second period, after which it will slow-down again.



Fig. 3: Example of display information during process.

For the Operator, the following functions are available:

- **Display level / height or percentage**

This is the main display information of the F073-A. After selecting any other information, it will always return to this main display automatically.

Level is displayed on the upper-line of the display and the percentage, height or nothing on the bottom line (depending on the configuration settings).

When "-----" is shown, then the value is too high to be displayed. The arrows  $\blacktriangle$  indicate the increase/decrease of the level trend.

- **Programming the level alarm values**



Note !

**Note:** This function might not be accessible due to a configuration setting.

When the SELECT-key is pressed a few times, following level alarm values are displayed:

- low level alarm: enter here 40 USGAL for example,
- high level alarm: enter here 600 USGAL for example,

To change the alarm value, the following procedure must be executed:

- 1) press PROG: the word "PROGRAM" will flash or a pass code will be requested,
- 2) use  $\blacktriangleright$  to select the digits and  $\blacktriangle$  to increase that value,
- 3) confirm the new alarm value by pressing ENTER.



Fig. 4: Example of display information during programming minimum level.

When data is altered but ENTER has not been pressed yet, then the alteration can still be cancelled by waiting for 20 seconds or by pressing ENTER during three seconds: the former value will be reinstated.

- **Level alarm**

When the actual level is outside the allowed range, an alarm message will be displayed indicating the type of alarm: "LO LEVEL", "HI LEVEL".  
The alarm is terminated automatically as soon as the level is within its range again.

- **Low-battery alarm**

When the battery voltage drops, it must be replaced. At first "low-battery" will flash, but as soon as it is displayed continuously, the battery **MUST** be replaced shortly after!  
Only original batteries supplied by the manufacturer may be used, else the guarantee and liability will be terminated. The remaining lifetime after the first moment of indication is generally several days up to some weeks.



Fig. 5: Example of low-battery alarm.

- **Range error**

As soon as the input value is 5% outside the calibrated measuring range, "ALARM" will be displayed. Meanwhile, the calibrated value will be displayed.  
After pressing the SELECT key, the reason of the alarm will be displayed: "LO RANGE" or "HI RANGE".

- **Alarm 01-03**

When "ALARM" is displayed, press the SELECT key to display the reason of the alarm: 1-3.  
Please consult Appendix B: problem solving.



### 3. CONFIGURATION

#### 3.1. INTRODUCTION

This and the following chapters are exclusively meant for electricians and non-operators. In these, an extensive description of all software settings and hardware connections are provided.



Caution !

- *Mounting, electrical installation, start-up and maintenance of the instrument may only be carried out by trained personnel authorized by the operator of the facility. Personnel must read and understand this Operating Manual before carrying out its instructions.*
- *The F073-A may only be operated by personnel who are authorized and trained by the operator of the facility. All instructions in this manual are to be observed.*
- *Ensure that the measuring system is correctly wired up according to the wiring diagrams. The housing may only be opened by trained personnel.*
- *Take careful notice of the " Safety rules, instructions and precautionary measures " in the front of this manual.*

#### 3.2. PROGRAMMING SETUP-LEVEL

##### 3.2.1. GENERAL

Configuration of the F073-A is done at SETUP-level. SETUP-level is reached by pressing the PROG/ENTER key for 7 seconds; at which time, both arrows  $\blacktriangle$  will be displayed. In order to return to the operator level, PROG will have to be pressed for three seconds. Alternatively, if no keys are pressed for 2 minutes, the unit will exit SETUP automatically.

SETUP can be reached at all times while the F073-A remains fully operational.



Note !

**Note:** A pass code may be required to enter SETUP. Without this pass code access to SETUP is denied.

To enter SETUP-level:

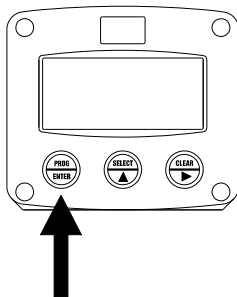

Press  for 7 seconds

Matrix structure SETUP-level:

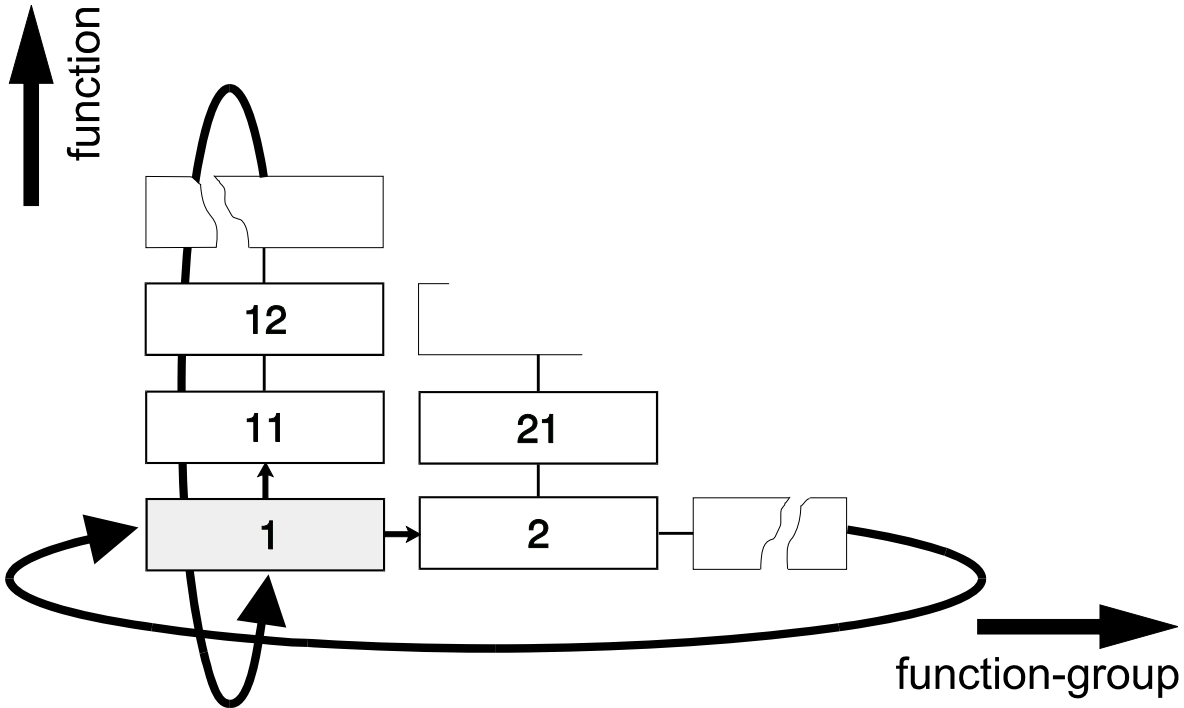

SCROLLING THROUGH SETUP-LEVEL

**Selection of function-group and function:**  
 SETUP is divided into several function groups and functions.

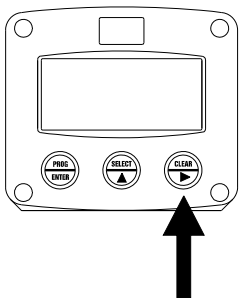

Select function-group with 

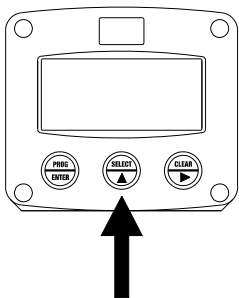

Select function with 



Each function has a unique number, which is displayed below the word "SETUP" at the bottom of the display. The number is a combination of two figures. The first figure indicates the function-group and the second figure the sub-function. Additionally, each function is expressed with a keyword.

After selecting a sub-function, the next main function is selected by scrolling through all "active" sub-functions (e.g. 1<sup>▲</sup>, 11<sup>▲</sup>, 12<sup>▲</sup>, 13<sup>▲</sup>, 14<sup>▲</sup>, 1<sup>▶</sup>, 2<sup>▶</sup>, 3<sup>▲</sup>, 31 etc.). The "CLEAR" button can be used to jump a step back if you missed the desired function.

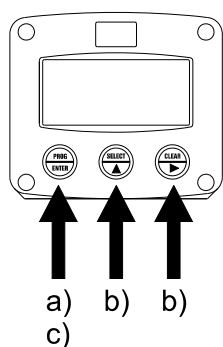

To change or select a value:







a) press  briefly; **PROGRAM** will start flash

b) select or enter value with  and / or 

c) press  to confirm the value / selection.

To change a value, use  to select the digits and  to increase that value.

If the new value is invalid, the increase sign  or decrease-sign  will be displayed while you are programming.

To select a setting,  is used to select in one direction and  can be used to select in the other direction.

When data is altered but ENTER is not pressed, then the alteration can still be cancelled by waiting for 20 seconds or by pressing ENTER for three seconds: the PROG-procedure will be left automatically and the former value reinstated.



Note !

**Note:** alterations will only be set after ENTER has been pressed!

To return to OPERATOR-level:

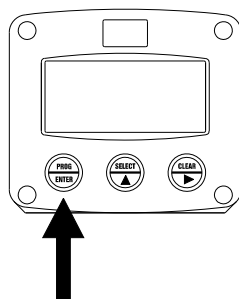

Press  for 3 seconds

In order to return to the operator level, PROG will have to be pressed for three seconds. Also, when no keys are pressed for 2 minutes, SETUP will be left automatically.

## 3.2.2. OVERVIEW FUNCTIONS SETUP LEVEL

SETUP FUNCTIONS AND VARIABLES			
<b>1</b>	<b>LEVEL</b>		
	11	UNIT	L - m3 - kg - lb - GAL - USGAL - bbl - no unit
	12	DECIMALS	0 - 1 - 2 - 3 (Ref: displayed value)
	13	SPAN	0.001 to 999,999 unit
	14	OFFSET	-999,999 to +999,999 unit
<b>2</b>	<b>HEIGHT</b>		
	21	UNIT	mm - cm - m - mtr - inch - ft - mmwk - mmwc - cmwk - cmwc - mwk - mwc - inwc - ftwc - mbar - bar - psi - no unit.
	22	DECIMALS	0 - 1 - 2 (Ref: displayed value)
	23	SPAN	0.01 to 999,999 unit
	24	OFFSET	-999,999 to +999,999 unit
<b>3</b>	<b>ALARM</b>		
	31	EMPTY	default - no relays - ignore
	32	ALARM LOW	-999,999 to +999,999 unit
	33	ALARM HIGH	-999,999 to +999,999 unit
	34	DELAY ALARM LOW	0.1 - 999.9 seconds
	35	DELAY ALARM HIGH	0.1 - 999.9 seconds
	36	ALARM OUTPUT	high - low - hi_lo - off
<b>4</b>	<b>DISPLAY</b>		
	41	FUNCTION	height - percentage - off
	42	SET ALARM	operator - setup
	43	BACKLIGHT (optional)	off - green - amber
	44	BACKLIGHT ALARM	off - on - flash
	45	BL. BRIGHTNESS	1 - 5
<b>5</b>	<b>POWER MANAGEMENT</b>		
	51	LCD UPDATE	fast - 1 sec - 3 sec - 15 sec - 30 sec - off
	52	BATTERY MODE	operational - shelf
<b>6</b>	<b>SENSOR</b>		
	61	FILTER	00 - 99
	62	CUT-OFF	0.0 - 99.9%
	63	CALIBRATE LOW	default - calibrate - calibrate set
	64	CALIBRATE HIGH	default - calibrate - calibrate set
<b>7</b>	<b>OTHERS</b>		
	71	TYPE / MODEL	F073-A
	72	SOFTWARE VERSION	03.03.xx
	73	SERIAL NO.	xxxxxxx
	74	PASS CODE	0000 - 9999
	75	TAGNUMBER	0000000 - 9999999

## 3.2.3. EXPLANATION OF SETUP-FUNCTIONS

<b>1 - LEVEL</b>	
<b>MEASUREMENT UNIT</b> 11	<p>SETUP - 11 determines the measurement unit for the displayed level and alarm values. The following units can be selected:</p> <p style="text-align: center;">L - m3 - kg - lb. - GAL - USGAL - bbl - _ (no unit).</p> <p>Alteration of the measurement unit will have consequences for operator and SETUP-level values. Please note that the Span has to be adapted as well; the calculation is not done automatically.</p>
<b>DECIMALS</b> 12	<p>This setting determines for level and the alarm values the number of digits following the decimal point. The following can be selected:</p> <p style="text-align: center;">00000 - 1111.1 - 2222.22 - 3333.333</p>
<b>SPAN</b> 13	<p>With the span, the sensor signal is converted to a quantity. The <b>span for level</b> is determined on the basis of the <b>selected measurement unit</b> at 20mA. Enter the span in whole numbers (decimals are set with SETUP 12). The more accurate the span, the more accurate the functioning of the system will be.</p> <p><b>Example 1     Calculating the span for level</b> <i>Let us assume that the sensor generates 20mA at a level of 2,481.3 Liters, the selected unit is "Liters". The span is 2481.3 Enter for SETUP - 13: "24813" and for SETUP - 12 - "1".</i></p> <p><b>Example 2     Calculating the span for level</b> <i>Let us assume that the sensor generates 20mA at a level of 652.31 USGAL, the selected unit is USG. The span is 652.31. Enter for SETUP - 13: "652.31 and for SETUP - 12 "2".</i></p>
<b>OFFSET</b> 14	<p>Enter here the "not measured" quantity which is below the sensor, in case a pressure transducer e.g. is used to measure the quantity. Also, a negative offset can be entered: do press the middle and right button simultaneously.</p>

<b>2 - HEIGHT</b>	
If desired the height of the level column can be calculated and displayed.	
<b>MEASUREMENT UNIT</b> <b>21</b>	<p>SETUP - 21 determines the measurement unit for height. The following units can be selected:</p> <p style="text-align: center;">mm - cm - m - mtr - inch - ft - mmwk - mmwc - cmwk - cmwc mwk - mwc - inwc - ftwc - mbar - bar - psi - no unit.</p> <p>Alteration of the measurement unit will have consequences for operator and SETUP-level values. Please note that the Span (23) has to be adapted as well; the calculation is not done automatically.</p>
<b>DECIMALS</b> <b>22</b>	<p>This setting determines for height the number of digits following the decimal point. The following can be selected:</p> <p style="text-align: center;">00000 - 1111.1 - 2222.22</p>
<b>SPAN</b> <b>23</b>	<p>With the span, the sensor signal is converted to a height. The <b>span for height</b> is determined on the basis of the <b>selected measurement unit</b> at 20mA. The more accurate the span, the more accurate the functioning of the system will be :</p> <p><b>Example      Calculating the span for height</b> <i>Let us assume that the sensor generates 20mA at a level of 2,481.3 cm, the selected unit is "cm". The span is 2481.3 Enter for SETUP - 23: "2481.3".</i></p>
<b>OFFSET</b> <b>24</b>	<p>Enter here the "not measured" height which is below the sensor, in case a pressure transducer is used for example to measure the level. Also, a negative offset can be entered: do press the middle and right button simultaneously.</p>



Note !

<b>3 - ALARM</b>	
<i>With these settings, it is determined how the level will be monitored and the functionality of the transistor / relay output (terminals 7-8) be determined.</i>	
<b>EMPTY 31</b>	When the level is zero (or the offset value setup 15), then it is possible to ignore or disable the level monitoring. The following settings can be selected: <b>DEFAULT:</b> in case of a low-level alarm and zero level, it will switch the alarm output and indicate the alarm on the display. <b>NO RELAY:</b> in case of a low-level alarm and zero level, it won't switch the alarm output but will indicate the alarm on the display only. <b>IGNORE:</b> in case of a low-level alarm and zero level, it won't switch the alarm output and nothing will be indicated on the display.
<b>ALARM VALUE LOW LEVEL 32</b>	The low alarm is set with this setting. An alarm will be generated as long as the level lower as this value. With value 0.0 this function is disabled.
<b>ALARM VALUE HIGH LEVEL 33</b>	The high alarm is set with this setting. An alarm will be generated as long as the level higher as this value. With value 0.0 this function is disabled.
<b>DELAY TIME ALARM LOW LEVEL 34</b>	An alarm generated by SETUP 32 "low" can be ignored during X-time period. If the actual level is still incorrect after this delay time, then an alarm will be generated.
<b>DELAY TIME ALARM HIGH LEVEL 35</b>	An alarm generated by SETUP 33 "high" can be ignored during X-time period. If the actual level is still incorrect after this delay time, then an alarm will be generated.
<b>ALARM OUTPUT TRANSISTOR / RELAY 36</b>	One transistor or relay output is available to transmit the alarm condition. Assign with this function the type of alarm to be transmitted: low level alarm, high level alarm or both alarms (hi_lo).

<b>4 - DISPLAY</b>	
<b>FUNCTION 41</b>	The small 8mm digits can be set to display:  height - percentage - off
<b>SET ALARM 42</b>	This function determines if the level alarm values can be set at both Operator level and SETUP-level or SETUP-level only. If SETUP has been selected, the alarm values are still visible for the Operator but can not be changed.
The functions below will only effect the optional LED-backlight.	
<b>BACKLIGHT (OPTION) 43</b>	If a LED backlight has been supplied, the color can be selected. Following selections are available:  OFF - GREEN - AMBER
<b>BACKLIGHT ALARM (OPTION) 44</b>	In case the F073-A generates a level alarm, the backlight can be set to change to red. Following selections are available:  OFF: during level alarm the color is according to setting 43 ON: during level alarm the color is red. FLASH: during level alarm the color flashes red and the color as set with SETUP 43.
<b>BRIGHTNESS (OPTION) 45</b>	The density of the backlight can be set in following range:  1 - 5  One is minimum and five is maximum brightness.

## 5 - POWER MANAGEMENT

When used with the internal battery option, the user can expect reliable measurement over a long period of time. The F073-A has several smart power management functions to extend the battery life time significantly. Two of these functions can be set:

### LCD NEW 51

The calculation of the display-information influences the power consumption significantly. When the application does not require a fast display update, it is **strongly advised** to select a slow refresh rate. Please understand that NO information will be lost; the input signal will be processed and the output signal will be generated in the normal way. The following can be selected:

Fast - 1 sec - 3 sec - 15 sec - 30 sec - off.

#### **Example battery life-time:**

*battery life-time with a FAST update: about 3 years.*

*battery life-time with a 1 sec update: about 5 years.*

**Note:** *after a button has been pressed by the operator - the display refresh rate will always switch to FAST for 30 seconds. When "OFF" is selected, the display will be switched off after 30 seconds and will be switched on as soon as a button has been pressed.*

### BATTERY-MODE 52

The unit has two modes: operational or shelf. After "shelf" has been selected, the unit can be stored for several years; it will not process the sensor signal; the display is switched off but all settings are stored. In this mode, power consumption is extremely low. To wake up the unit again, press the SELECT-key twice.



Note !





Note !

## 6 - SENSOR

<b>FILTER 61</b>	<p>The analog output signal of a sensor does mirror the actual level. This signal is measured several times a second by the F073-A. The value measured is a "snap-shot" of the real level as it will be fluctuating. With the help of this digital filter a stable and accurate reading can be obtained while the filter level can be set to a desired value.</p> <p>The filter principal is based on three input values: the filter level (01-99), the last measured analog value and the last average value. The higher the filter level, the longer the response time on a value change will be. Below, several filter levels with there response times are indicated:</p>													
<b>FILTER VALUE</b>	<b>RESPONSE TIME ON STEP CHANGE OF ANALOG VALUE. TIME IN SECONDS</b>													
	<b>50% INFLUENCE</b>	<b>75% INFLUENCE</b>	<b>90% INFLUENCE</b>	<b>99% INFLUENCE</b>										
01	filter disabled	filter disabled	filter disabled	filter disabled										
02	0.3 seconds	0.5 seconds	1.0 seconds	1.8 seconds										
03	0.5 seconds	1.0 seconds	1.5 seconds	3 seconds										
05	1.0 seconds	1.8 seconds	2.8 seconds	5.3 seconds										
10	1.8 seconds	3.5 seconds	5.6 seconds	11 seconds										
20	3.5 seconds	7.0 seconds	11 seconds	23 seconds										
30	5.3 seconds	10 seconds	17 seconds	34 seconds										
50	8.8 seconds	17 seconds	29 seconds	57 seconds										
75	13 seconds	26 seconds	43 seconds	86 seconds										
99	17 seconds	34 seconds	57 seconds	114 seconds										
<b>CUT-OFF 62</b>	<p>To ignore e.g. vibration due to an empty tank, a low-level cut-off can be set as percentage over the full range of 16mA (or 20mA). When the analog value is less then required with this setting, the signal will be ignored.</p> <p>The cut-off value can be programmed is the range 0.0 - 99.9%.</p> <p><b>Examples:</b></p> <table border="1" style="width: 100%; border-collapse: collapse; margin-top: 10px;"> <thead> <tr> <th style="width: 15%;"></th> <th style="width: 15%;">SPAN (setup 13)</th> <th style="width: 15%;">REQUIRED CUT-OFF</th> <th style="width: 15%;">CUT-OFF (setup 62)</th> <th style="width: 40%;">REQUIRED OUTPUT</th> </tr> </thead> <tbody> <tr> <td></td> <td style="text-align: center;">450 L</td> <td style="text-align: center;">25 L</td> <td style="text-align: center;"><math>25/450 \times 100\% = 5.5\%</math></td> <td style="text-align: center;"><math>16\text{mA} \times 5.5\% + 4\text{mA} = 4.88\text{mA}</math></td> </tr> </tbody> </table>					SPAN (setup 13)	REQUIRED CUT-OFF	CUT-OFF (setup 62)	REQUIRED OUTPUT		450 L	25 L	$25/450 \times 100\% = 5.5\%$	$16\text{mA} \times 5.5\% + 4\text{mA} = 4.88\text{mA}$
	SPAN (setup 13)	REQUIRED CUT-OFF	CUT-OFF (setup 62)	REQUIRED OUTPUT										
	450 L	25 L	$25/450 \times 100\% = 5.5\%$	$16\text{mA} \times 5.5\% + 4\text{mA} = 4.88\text{mA}$										
<b>TUNE MIN / 4MA 63</b>	<p>With this setting it is possible to calibrate the input value for (0)4mA as the signal from the sensor might not be exact 4.0 mA (or 0.0 mA) at level zero.</p> <p>This function will measure the real output value at level zero.</p> <p><i>Please note: the input loop powered version - type A-PL - requires a signal from 4mA and not lower!</i></p> <ul style="list-style-type: none"> <li>▪ <i>Warning: be very sure that the offered signal is correct before the calibration is executed as this function has major influences on the accuracy of the system!</i></li> </ul> <p>After pressing PROG, three settings can be selected:</p> <ul style="list-style-type: none"> <li>▪ CALIBRATE: with this setting, the input will be calibrated with the actual "(0)4mA" value. After pressing enter, CAL SET will be displayed as soon as the calibration is completed. From that moment, the analog value must be more than the calibrated value before the signal will be processed.</li> <li>▪ DEFAULT: with this setting, the manufactures value is re-installed.</li> <li>▪ CAL SET: to select the last calibrated value.</li> </ul>													
Continued next page >>>														



Note !



## 6 - SENSOR (CONTINUED)



<b>TUNE MAX / 20MA</b> <b>64</b>	<p>With this setting it is possible to calibrate the input value for 20mA as the signal from the sensor might not be exact 20.0 mA at maximum level. This function will measure the real output value at maximum level.</p> <ul style="list-style-type: none"> <li>▪ <i>Warning: be very sure that the offered signal is correct before the calibration is executed as this function has major influences on the accuracy of the system!</i></li> </ul> <p>After pressing PROG, three settings can be selected:</p> <ul style="list-style-type: none"> <li>▪ CALIBRATE: with this setting, the input will be calibrated with the actual "20mA" value. After pressing enter, CAL SET will be displayed as soon as the calibration is completed. From that moment, the analog value must be less than the calibrated value for a reliable measurement.</li> <li>▪ DEFAULT: with this setting, the manufactures value is re-installed.</li> <li>▪ CAL SET: to select the last calibrated value.</li> </ul>
-------------------------------------	---

## 7 - OTHERS

<b>TYPE OF MODEL</b> <b>71</b>	<p>For support and maintenance it is important to have information about the characteristics of the F073-A. Your supplier will ask for this information in the case of a serious breakdown or to assess the suitability of your model for upgrade considerations.</p>
<b>VERSION SOFTWARE</b> <b>72</b>	<p>For support and maintenance it is important to have information about the characteristics of the F073-A. Your supplier will ask for this information in the case of a serious breakdown or to assess the suitability of your model for upgrade considerations.</p>
<b>SERIAL NUMBER</b> <b>73</b>	<p>For support and maintenance it is important to have information about the characteristics of the F073-A. Your supplier will ask for this information in the case of a serious breakdown or to assess the suitability of your model for upgrade considerations.</p>
<b>PASS CODE</b> <b>74</b>	<p>All SETUP-values can be pass code protected. This protection is disabled with value 0000 (zero). Up to and including 4 digits can be programmed, for example 1234.</p>
<b>TAGNUMBER</b> <b>75</b>	<p>For identification of the unit and communication purposes, a unique tag number of maximum 7 digits can be entered.</p>

## 4. INSTALLATION

### 4.1. GENERAL DIRECTIONS



- *Mounting, electrical installation, start-up and maintenance of this instrument may only be carried out by trained personnel authorized by the operator of the facility. Personnel must read and understand this Operating Manual before carrying out its instructions.*
- *The F073-A may only be operated by personnel who are authorized and trained by the operator of the facility. All instructions in this manual are to be observed.*
- *Ensure that the measuring system is correctly wired up according to the wiring diagrams. Protection against accidental contact is no longer assured when the housing cover is removed or the panel cabinet has been opened (danger from electrical shock). The housing may only be opened by trained personnel.*
- *Take careful notice of the " Safety rules, instructions and precautionary measures " at the front of this manual.*

### 4.2. INSTALLATION / SURROUNDING CONDITIONS

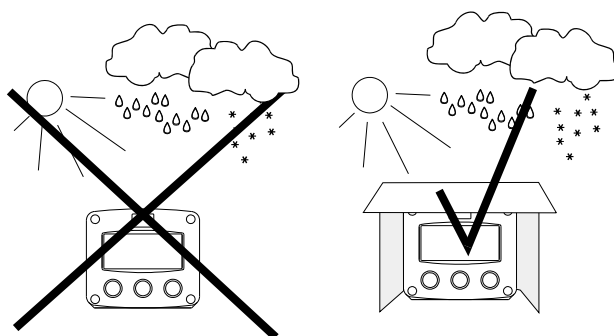

Take the relevant IP classification of the casing into account (see manufactures plate). Even an IP67 (NEMA 4X) casing should NEVER be exposed to strongly varying (weather) conditions.

When panel-mounted, the unit is IP65 (NEMA 4)!

When used in very cold surroundings or varying climatic conditions, take the necessary precautions against moisture by placing a dry sachet of silica gel, for example, inside the instrument case.

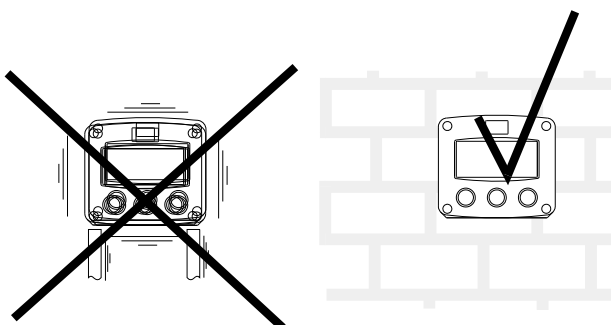

Mount the F073-A on a solid structure to avoid vibrations.

4.3. DIMENSIONS- ENCLOSURE

Aluminum enclosures:

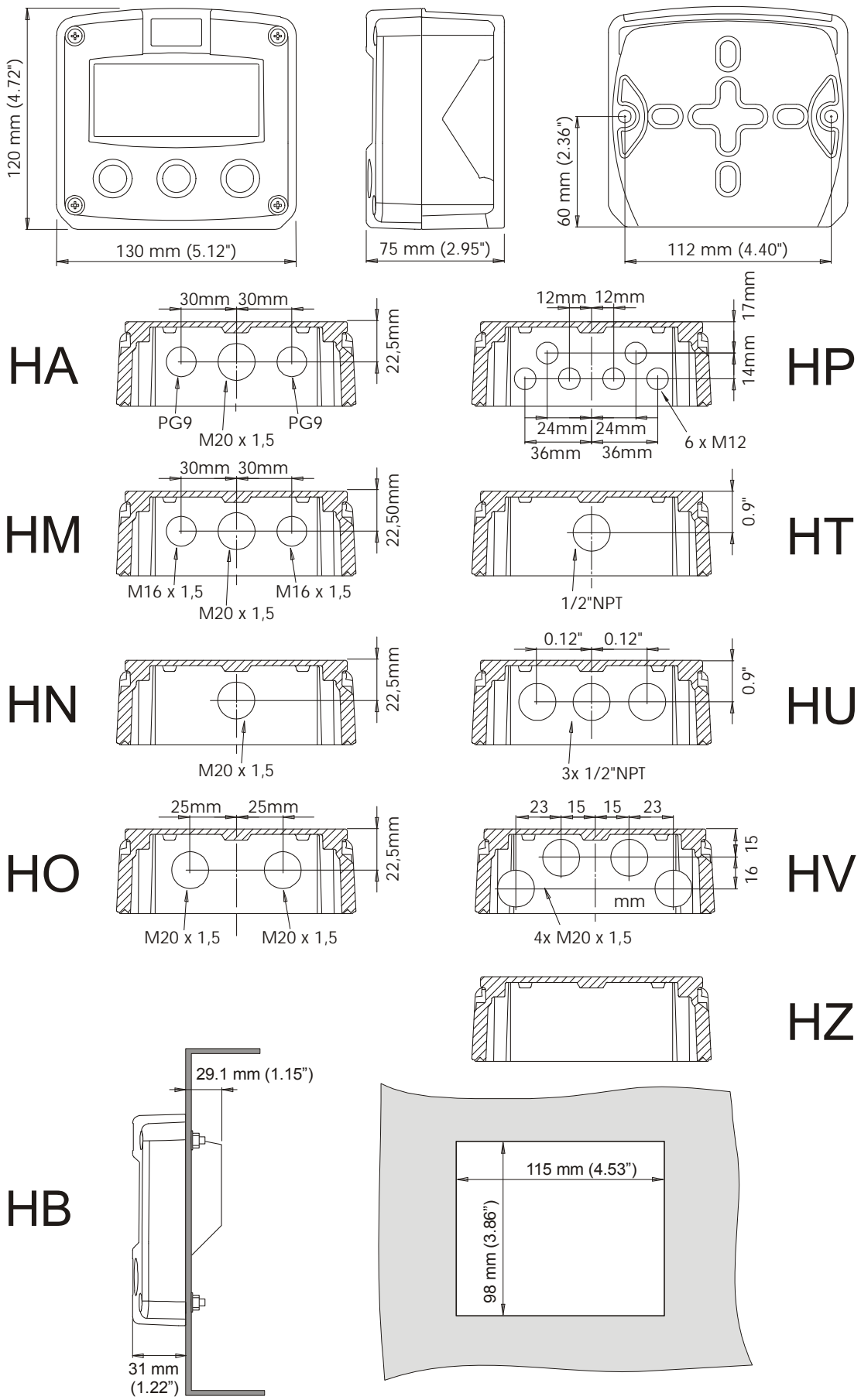
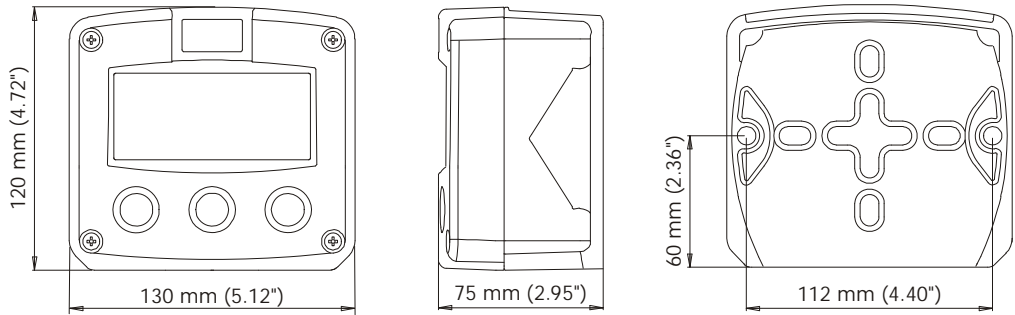
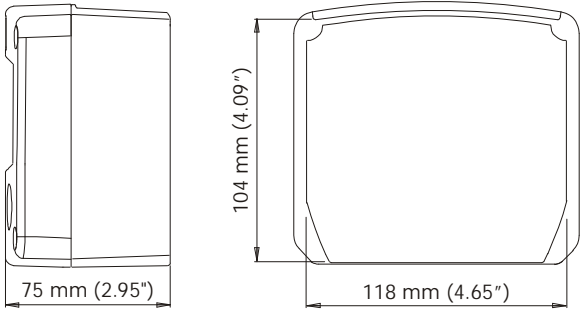

Fig. 6: Dimensions Aluminum enclosures.  
 HF073AEN\_v0403\_03 Atex\_IECEX\_CSA\_FM

GRP enclosures:



HK back box:  
(flat bottom)



HD  
HK

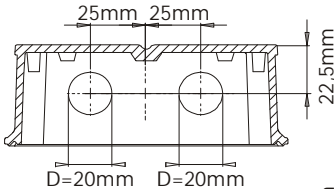
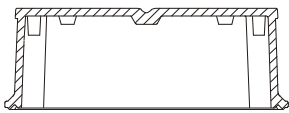

HG

HE

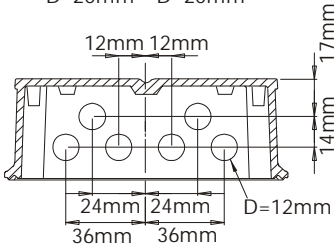
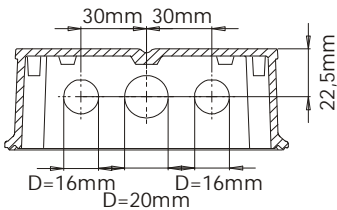

HH

HF

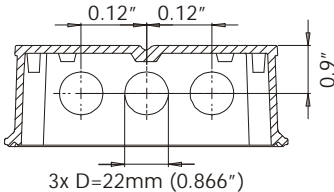
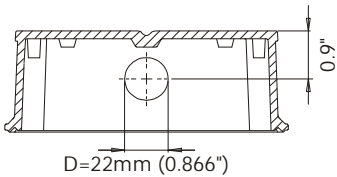

HJ

HC

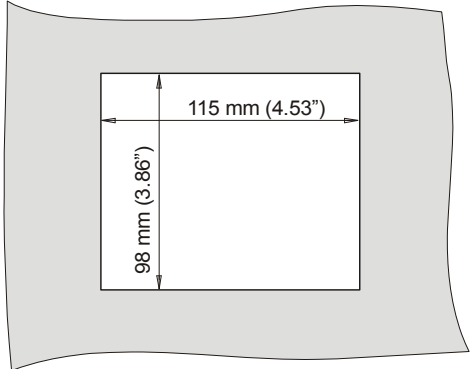
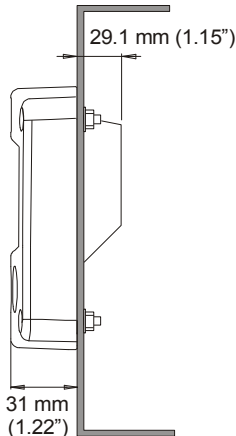

Fig. 7: Dimensions GRP enclosures.

#### 4.4. INSTALLING THE HARDWARE

##### 4.4.1. INTRODUCTION



- *Electro static discharge does inflict irreparable damage to electronics! Before installing or opening the unit, the installer has to discharge himself by touching a well-grounded object.*



- *This unit must be installed in accordance with the EMC guidelines (Electro Magnetic Compatibility).*



- *Do ground the aluminum casing properly as indicated, if the F073-A has been supplied with the 115-230V AC power-supply type PM. The green / yellow wire between the back-casing and removable terminal-block may never be removed.*

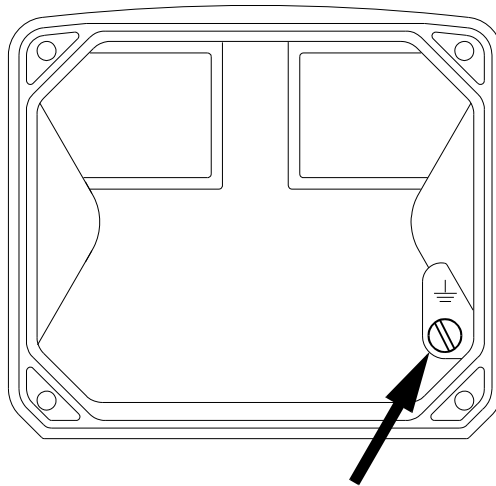

Fig. 8: Grounding aluminum enclosure with option PM 115-230V AC.

#### FOR INSTALLATION, PAY EMPHATIC ATTENTION TO:

- Separate cable glands with effective IP67 (NEMA4X) seals for all wires.
- Unused cable entries: ensure that you fit IP67 (NEMA4X) plugs to maintain rating.
- A reliable ground connection for both the sensor, and if applicable, for the metal casing. (above)
- An effective screened cable for the input signal, and grounding of it's screen to the "⊥" terminal or at the sensor itself, whichever is appropriate to the application.

#### 4.4.2. TERMINAL CONNECTORS WITH POWER SUPPLY - TYPE : PB / PD / PL / PX

For *Intrinsically Safe* applications: read chapter 5.

The following terminal connectors are available:

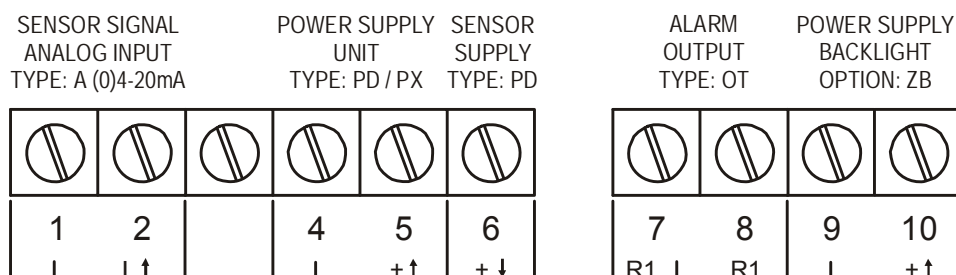

Fig. 9: Overview of terminal connectors F073-A-(PB / PD / PL / PX) and options.

#### REMARKS: TERMINAL CONNECTORS:

##### Terminals 1-2; Sensor input – type A:

The F073-A requires a (0)4-20mA sensor signal which will be processed 4 times a second with a 16 bits accuracy. The input is not isolated.

The screen of the signal wire must be connected to the common ground terminal

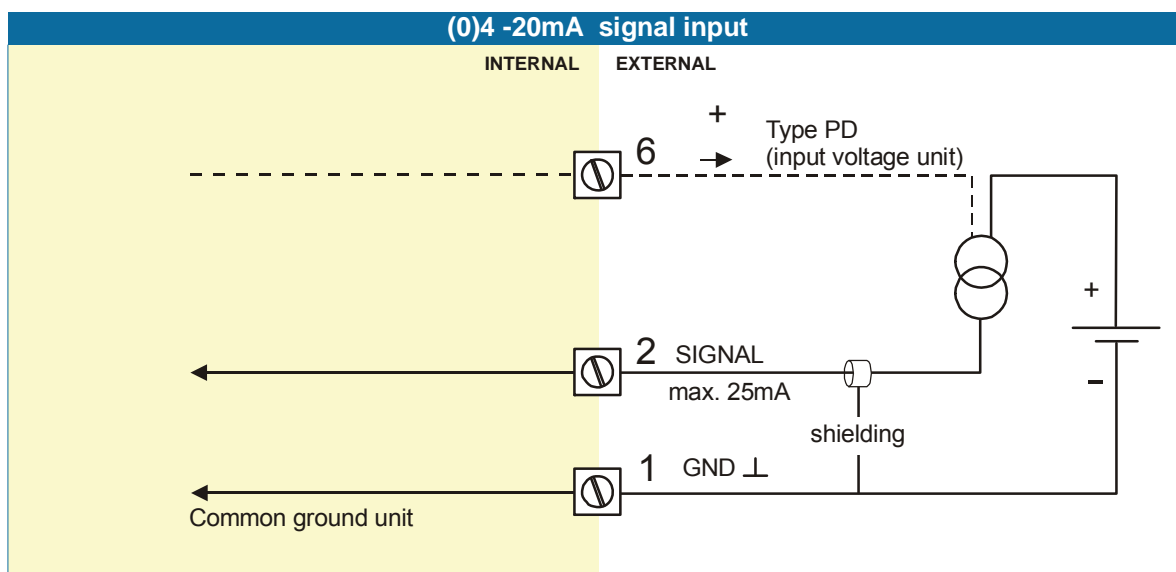

##### Terminals 1-2; sensor **INPUT LOOP POWERED** - type A-PL:

Model F073-A-PL is powered from the 4-20mA sensor signal. In the mean time, the unit will process the signal four times a second with a 16 bit accuracy. The input is not isolated.

The screen of the signal wire must be connected to the common ground terminal 1.

**Terminal 4-5: POWER SUPPLY UNIT - type PD / PX:**

To power the unit an internal battery can be used (type PB) and / or an external DC power supply of 8-30V DC (type PX) or 16-30V DC (type PD).  
Connect the "-" to terminal 4 and the "+" to terminal 5. When power is applied to these terminals, the optional internal battery will be disabled / enabled automatically to extend the battery life time.  
The input loop powered model - type A-PL - does not have this power supply option.

**Terminal 6: sensor supply voltage - type PD.**

With this option, a sensor supply terminal comes available which offers the same voltage as connected to terminal 5 (internally linked).  
Remark: this terminal is only available if option PD has been ordered.

**Terminal 7-8; alarm output – type OT:**

With SETUP 36, the function of this output is set to a low and / or high level alarm.  
A passive transistor output is available with this option. Max. driving capacity 300mA@50V DC.

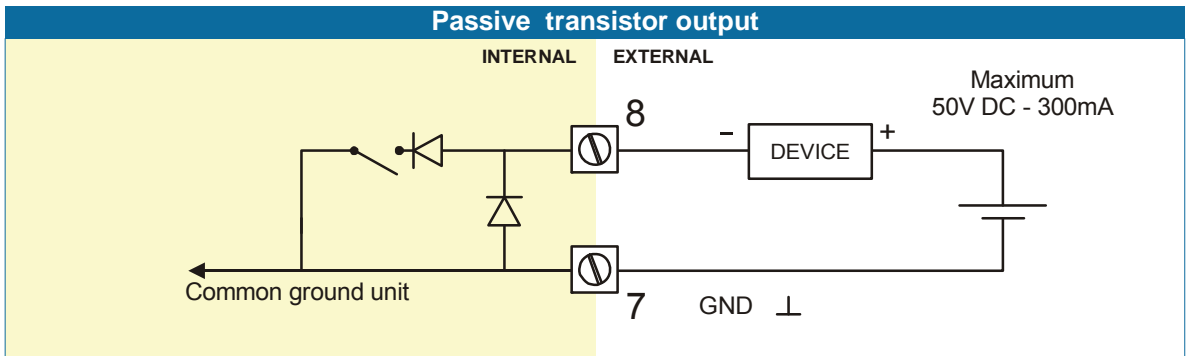

**Terminal 9-10: power supply backlight - type ZB (option):**

To power the backlight, a voltage in the range 20-30V DC has to be connected.  
Maximum current 30mA. Connect the "-" to terminal 9 and the "+" to terminal 10.



#### 4.4.3. TERMINAL CONNECTORS WITH POWER SUPPLY - TYPE : PF / PM

For *Intrinsically Safe* applications: read chapter 5.

The following terminal connectors are available:

POWER SUPPLY TYPE: PF / PM			ALARM OUTPUT TYPE: OA-OR-OT		SENSOR SIGNAL TYPE: A ANALOG (0)4-20mA		
GND ⊥	1 N	2 L1	3 R⊥	4 R	5 ⊥	6 I ↑	7 + ↓

Fig. 10: Overview of terminal connectors F073-A-(PF-PM) and options.

#### SENSOR SUPPLY

##### Type PF-PM: Sensor supply: 8.2V, 12V or 24 V:

With this option, a real power supply for the sensor is available. The sensor can be powered with 8.2, 12 or 24 V DC (max. 400mA@24V).

The voltage is selected with the three switches inside the enclosure.



- **Warning: be sure that all the leads to the terminals are disconnected from the unit when the internal plastic protection cover has been removed !**
- **HIGH VOLTAGE 400V !! NEVER connect the mains power supply to the unit when the plastic protection cover has been removed !!!**

First, remove the terminal strip(s) after which the internal plastic cover can be removed. The switches are located on the right hand (option PF / PM) as indicated:

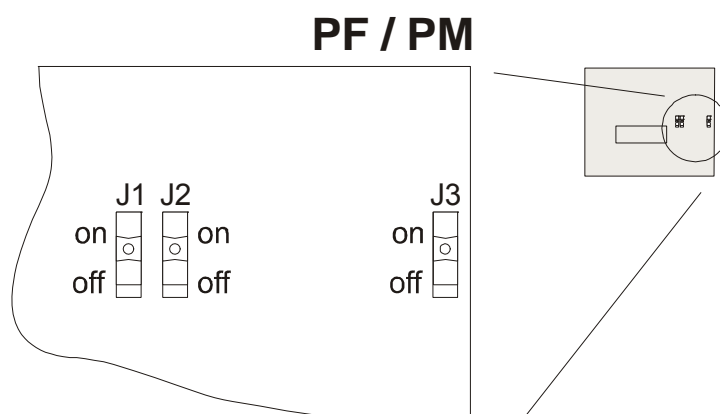

Fig. 11: switch position voltage selection (type PF and PM).

#### Switch positions / sensor supply voltage

VOLTAGE SELECTION			
SWITCH	8.2V DC	12V DC	24V DC
J1	off	off	off
J2	on	on	off
J3	on	off	on or off

**REMARKS: TERMINAL CONNECTORS:**

**Terminal GND- 01- 02; POWER SUPPLY only available with type PF / PM:**

OPTION	SENSOR SUPPLY	Terminal		
		GND	01	02
PF 24V AC $\pm$ 10%	8.2, 12, 24V max. 400mA@24V DC		AC	AC
PF 24V DC $\pm$ 10%	8.2, 12, 24V max. 400mA@24V DC	L-	L+	
PM 115-230V AC $\pm$ 10%	8.2, 12, 24V max. 400mA@24V DC	EARTH	AC	AC
Note PF / PM	The total consumption of the sensor, transistor output type OA and backlight type ZB may not exceed 400mA@24V DC.			

**Terminal 3-4; Alarm output:**

With SETUP 36, the function of this output is set to a low and / or high level alarm output.

**Type OT:**

A passive alarm output is available with this option. Max. driving capacity 300mA@50V DC.

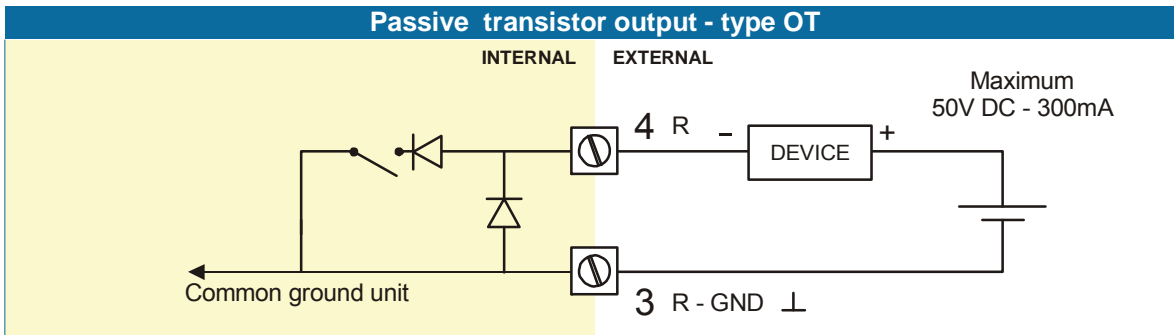

**Type OA:**

An active 24V DC signal alarm output is available with this option.  
Max. driving capacity 400mA@24V DC. (Requires power supply type PF / PM).

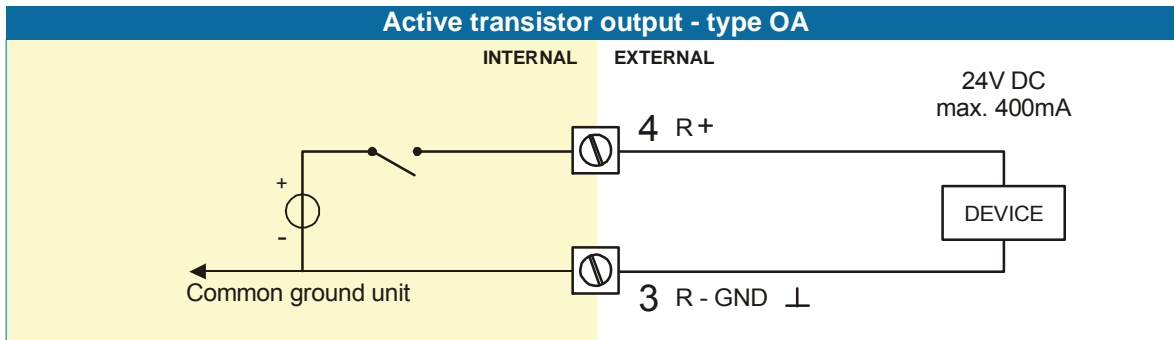

**Type OR:**

An isolated mechanical relay alarm output is available with this option.  
Max. switch power 240V 0,5A. (Requires power supply type PF / PM).

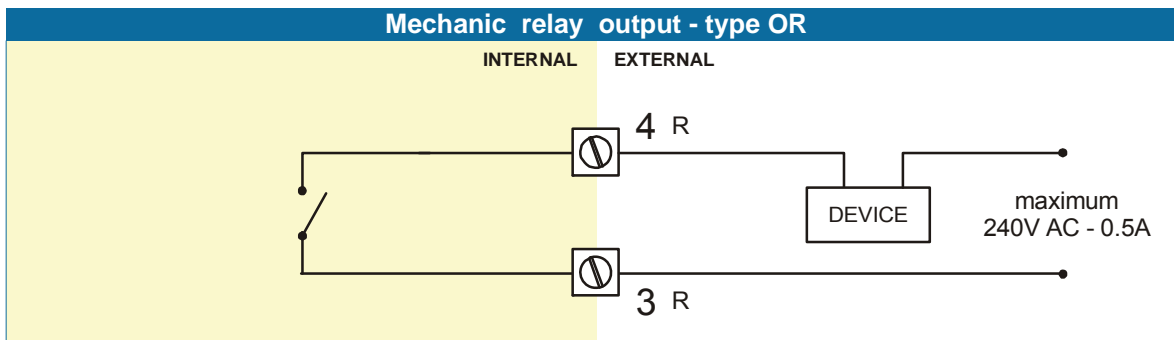

**Terminals 5-7; Sensor input:**

The F073-A requires a (0)4-20mA sensor signal which will be processed 4 times a second with a 16 bits accuracy. The input is not isolated.

The screen of the signal wire must be connected to the common ground terminal 5.

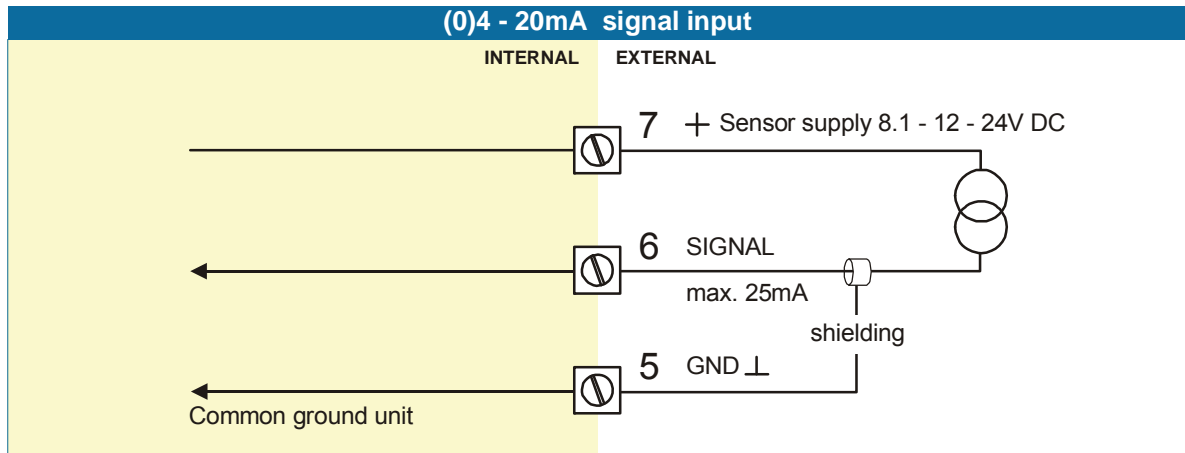

## 5. INTRINSICALLY SAFE APPLICATIONS

### 5.1. GENERAL INFORMATION AND INSTRUCTIONS:



- *Mounting, electrical installation, start-up and maintenance of this device may only be carried out by trained personnel authorized by the operator of the facility. Personnel must read and understand this Operating Manual before carrying out its instructions.*
- *This device may only be operated by personnel who are authorized and trained by the operator of the facility. All instructions in this manual are to be observed.*
- *Ensure that the measuring system is correctly wired up according to the wiring diagrams. Protection against accidental contact is no longer assured when the housing cover is removed or the cabinet has been opened (danger of electric shock). The housing may only be opened by trained personnel.*
- *Take careful notice of the " Safety rules, instructions and precautionary measures " in the front of this manual.*

#### Safety Instructions



- *Certificates, safety values, control drawing and declaration of compliance can be found in the document named: "Fluidwell F0..-A-XI - Documentation for Intrinsic Safety".*
- *For installation under ATEX directive: this intrinsically safe device must be installed in accordance with the Atex directive 94/9/EC and the product certificate KEMA 05ATEX1168 X.*
- *For installation under IECEx scheme: this intrinsically safe device must be installed in accordance the product certificate IECEx KEM 08.0006X.*
- *For installation under FM: this intrinsically safe device must be installed in accordance with the Certificate / Project ID: 3033306.*
- *The control drawing number FWCD-0001 can be found in the document named: "Fluidwell F0..-A-XI - Documentation for Intrinsic Safety".*
- *The control drawing number FWCD-0002 can be found in the document named: "Fluidwell F0..-A-PL-XI - Documentation for Intrinsic Safety".*
- *Exchange of Intrinsically Safe battery FWLiBAT-00x with certificate number KEMA 03ATEX1071 U or IECEx KEM 08.0005U is allowed in Hazardous Area. See paragraph 5.4. for battery replacement instructions.*

#### Please note



- *Special conditions for safe use mentioned in both the certificate and the installation instructions must be observed for the connection of power to both input and / or output circuits.*
- *When installing this device in hazardous areas, the wiring and installation must comply with the appropriate installation standards for your industry.*
- *Study the following pages with wiring diagrams per classification.*

#### Serial number and year of production

This information can be looked-up on the display: setup function (par. 3.2.2.).

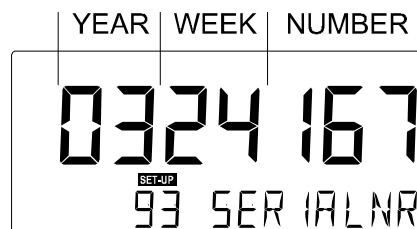

Fig. 12: Example serial number.

Label information analog input type - F0..A-XI (inside and outside the enclosure)

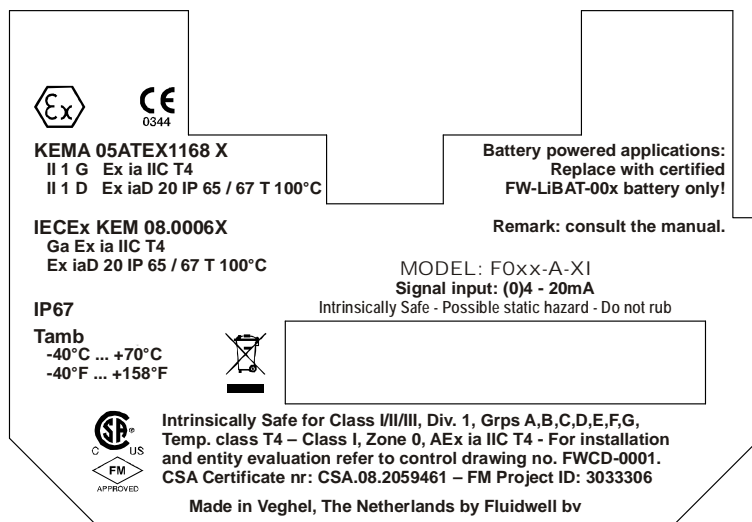
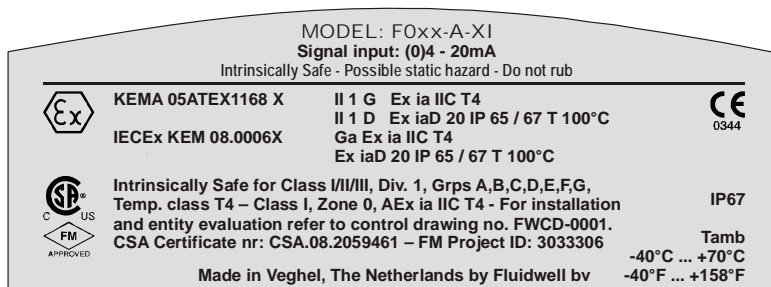

Fig. 13: Label information Intrinsically Safe application.

Label information analog input - loop powered - type A-PL (inside and outside the enclosure)

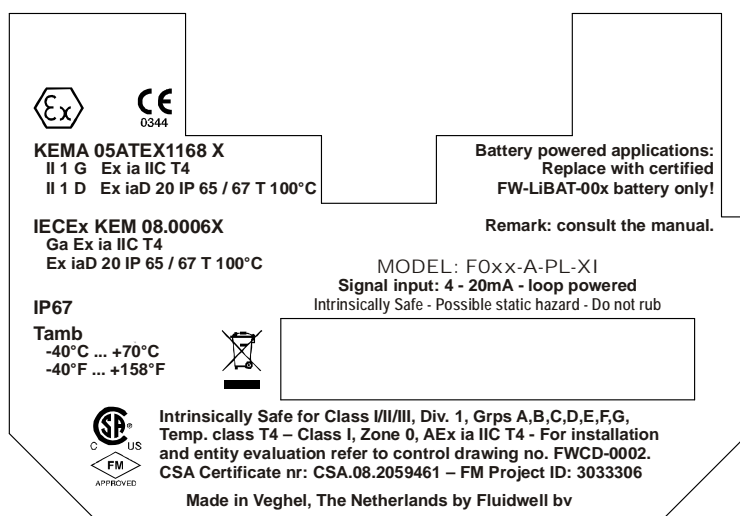
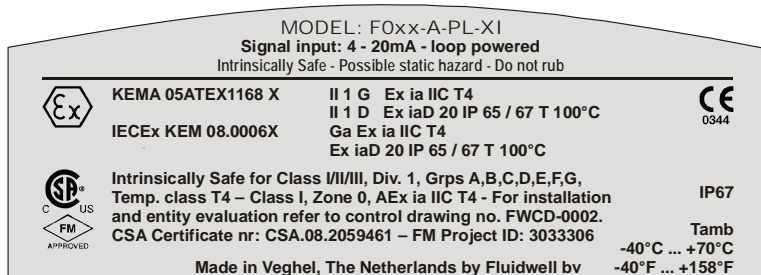

Fig. 14: Label information Intrinsically Safe application.

5.2. TERMINAL CONNECTORS INTRINSICALLY SAFE APPLICATIONS:

Terminal connectors F073-A-(PC / PD / PL / PX)-OT-XI-(ZB):

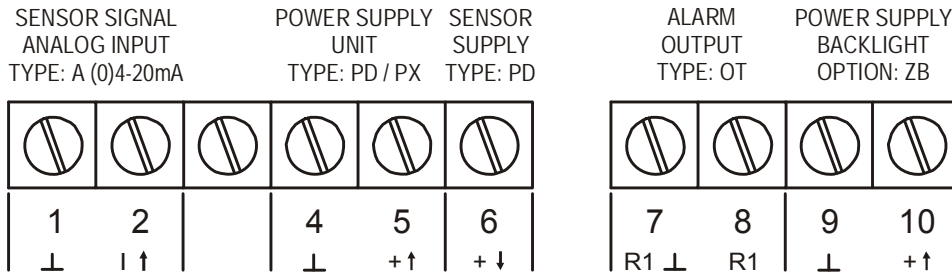

Fig. 15: Overview terminal connectors XI - Intrinsically Safe applications.

Remarks power supply options:

**Type PC:** offers - additional to type PX - an internal Intrinsically Safe lithium battery. This ATEX certified battery (FW-LiBATT-xxx) may be changed in hazardous area.

**Type PD:** offers - additional to type PX - a sensor supply terminal (terminal 6) which offers the same voltage as connected to terminal 5 (internally linked).

**Type PL:** the unit will be powered from the 4-20mA input signal. Terminal 4-6 are not available.

**Type PX:** as standard, all intrinsically product are supplied with terminal 4 and 5 to power the product externally.

5.3. CONFIGURATION EXAMPLES INTRINSICALLY SAFE APPLICATIONS:

Configuration example no. 1

Configuration example IIA - IIB and IIC application - F073-A-OT-PX-XI-ZB

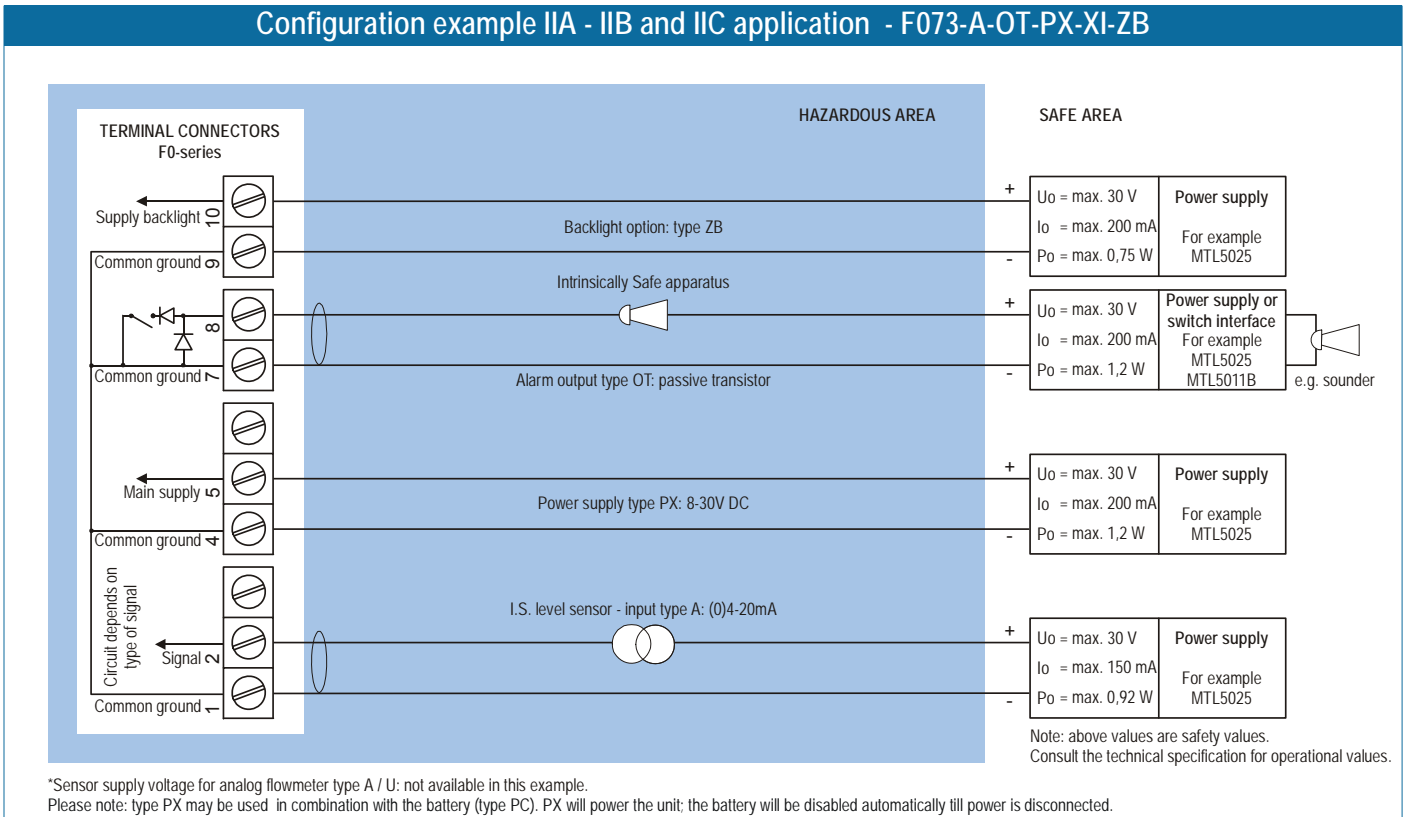
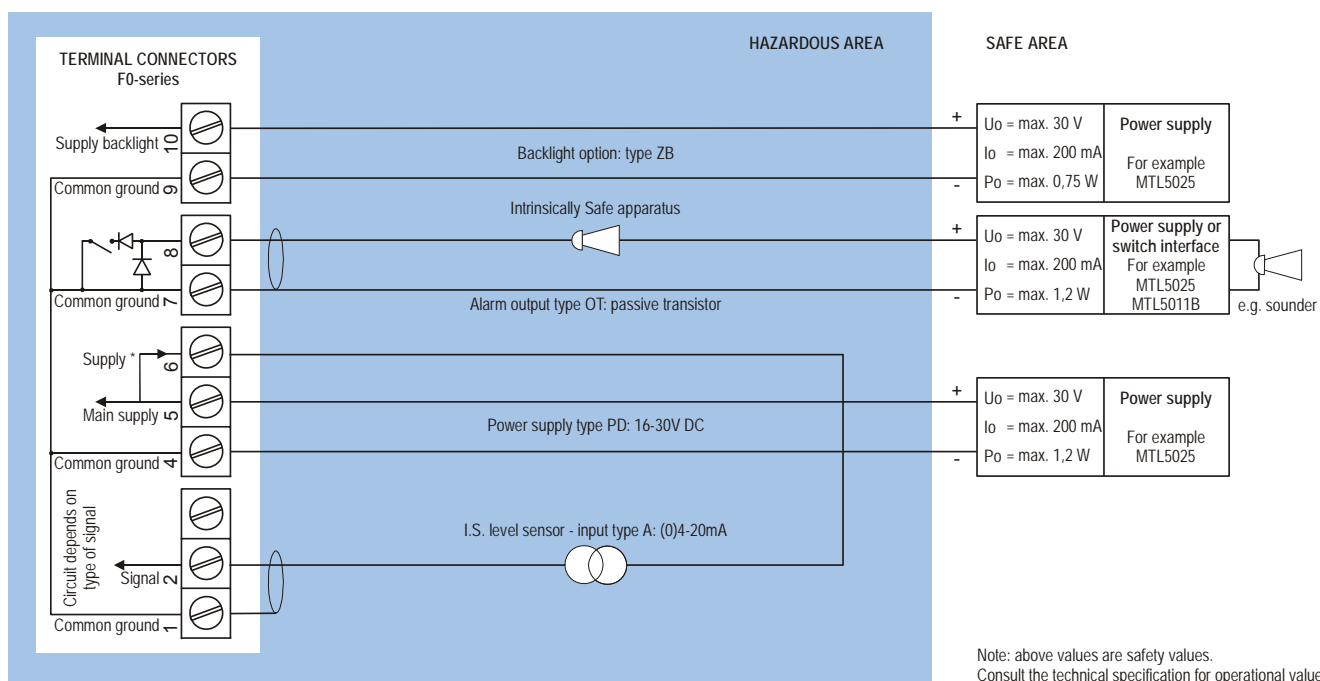

Fig. 16: Configuration example Intrinsically Safe.

Configuration example no. 2

Configuration example IIA - IIB and IIC application - F073-A-OT-PD-XI-ZB



\*Sensor supply voltage for analog flowmeter type A / U: Terminal 6: as input voltage terminal 5 (internally linked).  
Please note: type PD may be used in combination with the battery (type PC). PD will power the unit; the battery will be disabled automatically till power is disconnected.

Fig. 17: Configuration example Intrinsically Safe.

Configuration example no. 3

Configuration example IIA - IIB and IIC application - F073-A-OT-PL-XI-ZB

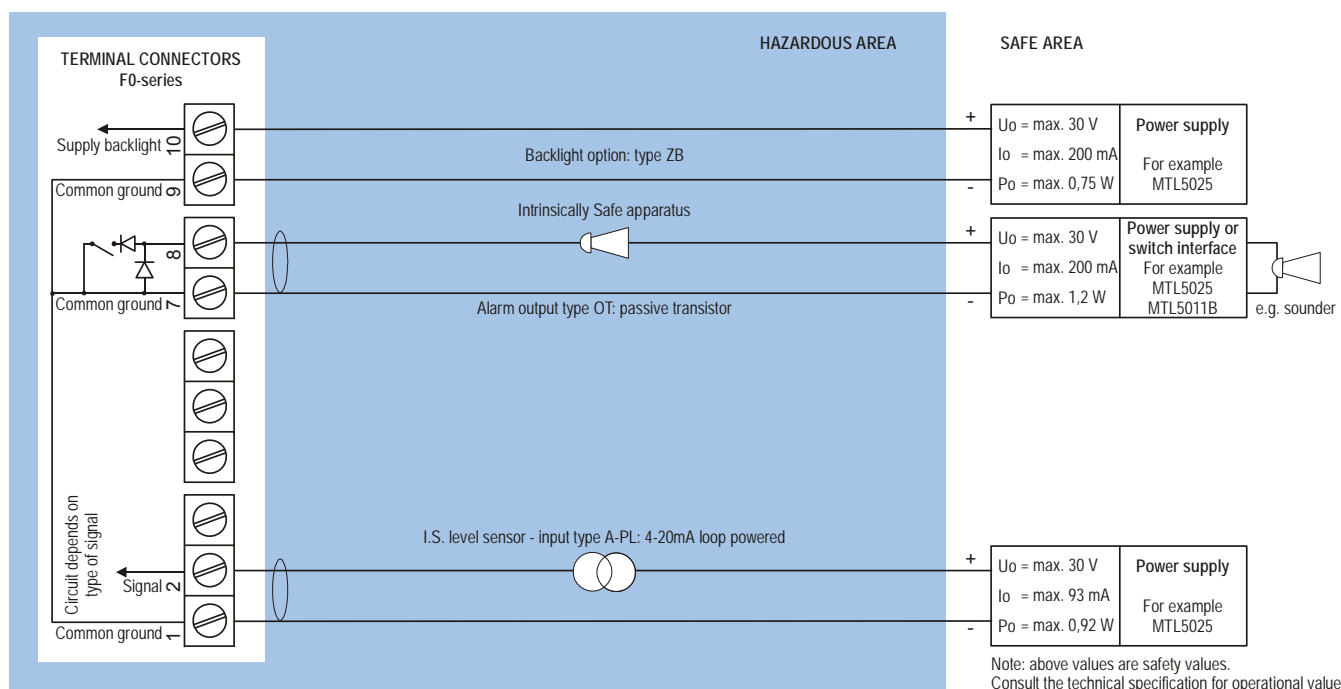

Sensor supply is not available: unit is input loop powered (type PL).  
Please note: type PL may be used in combination with the battery (type PC). PL will power the unit; the battery will be disabled automatically till power is disconnected.

Fig. 18: Configuration example Intrinsically Safe.

# INSTRUCTION SHEET BATTERY REPLACEMENT FW-LiBAT-001

**Manufacturer**

Fluidwell bv - The Netherlands  
 www.fluidwell.com - sales@fluidwell.com

**Safety Instructions**

**WARNING:** Fire, explosion or severe burns may result if mistreated. Do not recharge, crush, disassemble, incinerate, heat above 100°C (212°F) or expose contents to water.



**Replacement Instructions**

Mounting, electrical installation, start-up and maintenance of this device may only be carried out by trained personnel authorized by the operator of the facility. Personnel must read and understand this Instruction before carrying out its instructions.

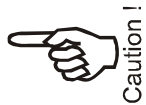

It is allowed to replace the Intrinsicly Safe battery FW-LiBAT-001 in hazardous area. The battery may only be replaced with an original FW-LiBAT-001 manufactured by Fluidwell bv.

For replacement, unplug the connector carefully and lift the old battery out of the mounting clip. The new battery can be placed in the clip and the connector plugged on the board.

**Disposal**

Disposal should be done in accordance with applicable regulations, which vary from country to country. Trashing of used batteries is forbidden and disposal can be done through non-profit organizations mandated by local authorities or organized by professionals.

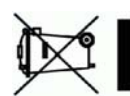

**Battery label:**

CE 0344	II 1 G Ex ia IIC	KEMA 03ATEX1071 U
Fluidwell bv - Intrinsicly Safe Battery	Ga Ex ia IIC	IECEX KEM 08.0005U
Part. no.: FW-LiBAT-001	Consult manual for replacement instructions.	
Uo = 3.9V	WARNING: Fire, explosion or severe burns may result if mistreated. Do not recharge, crush, disassemble, incinerate, heat above 100°C (212°F) or expose contents to water.	
Io = 35mA	Co = 100µF	
Po = 35mW	Lo = 25mH	
	Ta = -40°C to +70°C	
<b>Primary Lithium Battery - Only replace with Fluidwell I.S. battery pack!</b>		

**F0-series:**

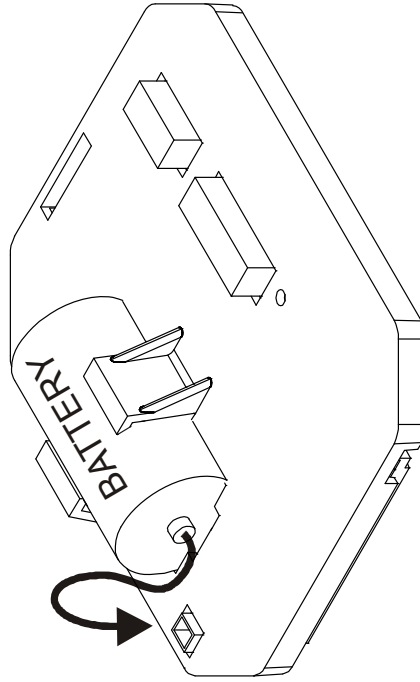

FW-LiBAT-001 - INST001

Fig. 19: Battery replacement instructions Intrinsicly Safe Battery.



## 6. MAINTENANCE

### 6.1. GENERAL DIRECTIONS



Caution !

- *Mounting, electrical installation, start-up and maintenance of the instrument may only be carried out by trained personnel authorized by the operator of the facility. Personnel must read and understand this Operating Manual before carrying out its instructions.*
- *The F073-A may only be operated by personnel who are authorized and trained by the operator of the facility. All instructions in this manual are to be observed.*
- *Ensure that the measuring system is correctly wired up according to the wiring diagrams. Protection against accidental contact is no longer assured when the housing cover is removed or the panel cabinet has been opened (danger from electrical shock). The housing may only be opened by trained personnel.*
- *Take careful notice of the " Safety rules, instructions and precautionary measures " in the front of this manual.*

The F073-A does not require special maintenance unless it is used in low-temperature applications or surroundings with high humidity (above 90% annual mean). It is the users responsibility to take all precautions to dehumidify the internal atmosphere of the F073-A in such a way that no condensation will occur, for example by placing dry silica-gel sachet in the casing just before closing it. Furthermore, it is required to replace or dry the silica gel periodically as advised by the silica gel supplier.

#### **Battery life-time:**

It is influenced by several issues :

- Display update: fast display update uses significantly more power.
- Alarm output.
- Low temperatures; the available power will be less due to battery chemistry.



Note !

**Note:** *It is strongly advised to use only necessary functions.*

#### **Check periodically:**

- The condition of the casing, cable glands and front panel.
- The input/output wiring for reliability and aging symptoms.
- The process accuracy. As a result of wear and tear, re-calibration of the sensor might be necessary. Do not forget to re-enter any subsequent span alterations.
- The indication for low-battery.
- Clean the casing with soapy-water. Do not use any aggressive solvents as these might damage the coating.

### 6.2. REPAIR

This product cannot be repaired by the user and must be replaced with an equivalent certified product. Repairs should only be carried out by the manufacturer or his authorized agent.

## APPENDIX A: TECHNICAL SPECIFICATION

### GENERAL

Display	
Type	High intensity reflective numeric and alphanumeric LCD, UV-resistant.
Digits	Seven 17mm (0.67") and eleven 8mm (0.31"). Various symbols and measuring units.
Refresh rate	User definable: 8 times/sec - 30 secs.
Type ZB (option)	Tri-color configurable LED-backlight - green, amber with red flashing during alarm. Intensity adjustable from the keyboard.

Enclosures	
General	Die-cast aluminum or GRP (Glassfibre Reinforced Polyamide) enclosure with Polycarbonate window, silicone and EPDM gaskets. UV stabilized and flame retardant material.
Control Keys	Three industrial micro-switch keys. UV-resistant silicone keypad.
Painting	Aluminum enclosure only: UV-resistant 2-component industrial painting.
Panel-mount enclosures	Dimensions: 130 x 120 x 60mm (5.10" x 4.72" x 2.38") – LxHxD.
Classification	IP65 / NEMA4
Panel cut-out	115 x 98mm (4.53" x 3.86") LxH.
Type HC	GRP panel-mount enclosure
Type HB	Aluminum panel-mount enclosure
Field/wall-mount enclosures	Dimensions: 130 x 120 x 75mm (5.10" x 4.72" x 2.95") – LxHxD.
Classification	IP67 / NEMA4X
Aluminum enclosures	
Type HA	Drilling: 2x PG9 – 1x M20.
Type HM	Drilling: 2x M16 – 1x M20.
Type HN	Drilling: 1x M20.
Type HO	Drilling: 2x M20.
Type HP	Drilling: 6x M12.
Type HT	Drilling: 1x ½"NPT.
Type HU	Drilling: 3x ½"NPT.
Type HV	Drilling: 4x M20
Type HZ	No drilling.
GRP enclosures	
Type HD	No drilling.
Type HE	Drilling: 2x 16mm (0.63") – 1x 20mm (0.78").
Type HF	Drilling: 1x 22mm (0.87").
Type HG	Drilling: 2x 20mm (0.78").
Type HJ	Drilling: 3x 22mm (0.87").
Type HH	Drilling: 6x 12mm (0.47").
Type HK	Flat bottom - no drilling.
ABS enclosure	
Type HS	Silicone free ABS enclosure with EPDM and PE gaskets. UV-resistant polyester keypad. (no drilling)

Operating temperature	
Operational	-40°C to +80°C (-40°F to +178°F).
Intrinsically Safe	-40°C to +70°C (-40°F to +158°F).

Power requirements	
Type PB	Lithium battery - life-time depends upon settings - up to 5 years.
Type PC	Intrinsically Safe lithium battery - life-time depends upon settings - up to 5 years.
Type PD	16-30 V DC. Power consumption max. 1 Watt.
Type PF	24V AC/DC $\pm$ 10%. Power consumption max. 15 Watt.
Type PL	Input loop powered from 4-20mA signal input. Voltage drop max. 2.6V DC
Type PM	115-230V AC $\pm$ 10%. Power consumption max. 15 Watt.
Type PX	8-30 V DC (also available with PB / PC). Power consumption max. 0.3 Watt.
Type ZB	20-30V DC. Power consumption max. 1 Watt. Note: with type PF / PM: internally powered.
Note PF / PM	The total consumption of the sensor, active output type OA and backlight type ZB may not exceed 400mA@24V DC.
Note I.S. application	for intrinsically safe applications, consult the safety values in the certificate.

Sensor excitation	
Type PB / PC / PL / PX	Sensor supply not available.
Type PD	As connected power supply voltage (internally linked)
Type PF / PM	Sensor supply voltage 8.2, 12 and 24V DC - max. 400mA@24V DC

Terminal connections	
Type:	Removable plug-in terminal strip. Wire max. 1.5mm <sup>2</sup> and 2.5mm <sup>2</sup>

Data protection	
Type	EEPROM backup of all setting. Data retention at least 10 years.
Pass code	Configuration settings can be pass code protected.

Hazardous area (option)	
Intrinsically safe Type XI	<p><b>ATEX approval:</b> II 1 G Ex ia IIC T4 II 1 D Ex iaD 20 IP 65 / 67 T 100°C</p> <p><b>IECEX approval:</b> Ga Ex ia IIC T4 Ex iaD 20 IP 65 / 67 T 100°C</p> <p><b>CSA / FM approval :</b> IS Class I/II/III, Division 1 Groups A to G T4 Class I zone 0 AEx ia IIC T4</p>
Explosion proof Type XF	ATEX approval ref.: <EX> II 2 GD EEx d IIB T5. Weight appr. 15kg. Dimensions of enclosure: 350 x 250 x 200mm (13.7" x 9.9" x 7.9") LxHxD.

Environment	
Electromagnetic compatibility	Compliant ref: EN 61326 (1997), EN 61010-1 (1993)
Low voltage directive	Compliant ref: EN60950.

## INPUTS

Sensor	
Type A	(0)4-20mA - with signal calibration feature.
Type U	0-10 V - with signal calibration feature.
Accuracy	Resolution: 16 bit.. Error < 0.01mA / ±0.05% FS. Low level cut-off programmable.
Span	0.001 - 999,999 with variable decimal position.
Offset	-99,999 to +99,999 units.
Update time	Four times a second.
Voltage drop	2.6 Volt.
Load impedance	3kOhm
Relationship	Linear calculation.
Note	For signal type A and U: external power to sensor is required; e.g. type PD / PF / PM.

## OUTPUTS

Transistor output	
Function	high, low or high and low level alarm.
Type OT	One passive transistor output - not isolated. Max. load 50V DC - 300mA
Type OA	One active 24V DC transistor output; max. 400mA per output (requires type PF or PM).
Type OR	Electro-mechanical relay output; max. switch power 230V AC - 0,5A (requires type PF or PM).

## OPERATIONAL

<b>Operator functions</b>	
Displayed functions	<ul style="list-style-type: none"> <li>level.</li> <li>height or percentage (or no indication).</li> <li>alarm value's low - high level.</li> <li>alarm value's can be entered (this function can be disabled).</li> </ul>

<b>Level</b>	
Digits	6 digits.
Units	L, m3, GAL, USGAL, KG, lb, bbl, no unit.
Decimals	0 - 1 - 2 or 3.

<b>Height</b>	
Digits	6 digits.
Units	mm - cm - m - mtr - inch - ft - mmwk - mmwc - cmwk - cmwc - mwk - mwc - inwc - ftwc - mbar - bar - psi - no unit.
Decimals	0 - 1 or 2.

<b>Percentage</b>	
Digits	3 digits.
Decimals	1.

<b>Alarm values</b>	
Digits	6 digits.
Units	According to selection for level.
Decimals	According to selection for level.
Type of alarm	low and high level alarm. Includes delay time alarm and configurable alarm output.

## APPENDIX B: PROBLEM SOLVING

In this appendix, several problems are included that can occur when the F073-A is going to be installed or while it is in operation.

### Level displays "0 / zero" while a higher signal is available:

Check:

- SETUP 13 / 23: is the span correct?
- SETUP 14 / 24: is the offset value correct?
- SETUP 63 / 64: is the sensor input signal correctly calibrated?

### The pass code is unknown:

If the pass code is not 1234, there is only one possibility left: call your supplier.

### Range error

- Range error (LO RANGE or HI RANGE): the input value is at least 5% above or below the calibrated measurement range SETUP 63, 64. Do recalibrate the input if desired.

### ALARM

When the alarm flag starts to blink an internal alarm condition has occurred. Press the "select button" several times to display the 4-digit error code. The codes are:

0001: irrecoverable display-data error: data on the display might be corrupted.

0002: irrecoverable data-storage error: the programming cycle might have gone wrong: check programmed values.

0003: error 1 and error 2 occurred simultaneously

The alarm condition will almost certainly be handled internally and if all mentioned values still appear correct, no intervention by the operator is needed. If the alarm occurs more often or stays active for a longer time, please contact your supplier.

## INDEX OF THIS MANUAL

actual settings	40	level	
alarm	8, 37	alarm	8
alarm output function	15	decimals	13, 14
alarm values	15	enter alarm value	7
delay time alarm	15	measuring unit	13, 14
display level zero	15	Span	14
set alarm operator level	15	Span	13
alarm output	26	loop powered	23
alarm values	7	low current	37
backlight	24	low-battery	8
alarm color	15	main-function	10
color	15	maintenance	33
density	15	manual version	3
battery life time	15, 16, 33	model	18
Battery replacement	32	operational	6
configuration	9	operator level	7
contents	4	pass code	18, 37
dimensions	20	power supply	24, 26
display		problem solving	37
function	15	range error	8, 37
display update time	16	safety instructions	2
functional description	5	sensor supply voltage	24, 25
hardware version	3	serial number	18
height / percentage	7	setup-level	9
high alarm output	24	signal input	23
high current	37	software version	3
input loop powered	23	subfunction	10
input signal	23	tagnumber	18
installation	19	technical specification	34
intrinsic safety	28	terminal connectors	23, 25
IP classification	19	version software	18
keys	6	voltage selection sensor supply	25

## LIST OF FIGURES IN THIS MANUAL

Fig. 1: Typical application for the F073-A.....	5
Fig. 2: Control Panel.....	6
Fig. 3: Example of display information during process. ....	7
Fig. 4: Example of display information during programming minimum level.....	7
Fig. 5: Example of low-battery alarm.....	8
Fig. 6: Dimensions Aluminum enclosures. ....	20
Fig. 7: Dimensions GRP enclosures. ....	21
Fig. 8: Grounding aluminum enclosure with option PM 115-230V AC.....	22
Fig. 9: Overview of terminal connectors F073-A-(PB / PD / PL / PX) and options. ....	23
Fig. 10: Overview of terminal connectors F073-A-(PF-PM) and options. ....	25
Fig. 11: switch position voltage selection (type PF and PM).....	25
Fig. 12: Example serial number. ....	28
Fig. 13: Label information Intrinsically Safe application. ....	29
Fig. 14: Label information Intrinsically Safe application. ....	29
Fig. 15: Overview terminal connectors XI - Intrinsically Safe applications.....	30
Fig. 16: Configuration example Intrinsically Safe.....	30
Fig. 17: Configuration example Intrinsically Safe.....	31
Fig. 18: Configuration example Intrinsically Safe.....	31
Fig. 19: Battery replacement instructions Intrinsically Safe Battery.....	32

LIST OF CONFIGURATION SETTINGS			
SETTING	DEFAULT	DATE :	DATE :
<b>1 - LEVEL</b>	Enter your settings here		
11 unit	L		
12 decimals	000000		
13 span	000001 L		
14 offset	000000 L		
<b>2 - HEIGHT</b>			
21 unit	m		
22 decimals	000000		
23 span	000001 m		
24 offset	000000 m		

SETTING	DEFAULT	DATE :	DATE :
<b>3 - ALARM</b>	Enter your settings here		
31 level zero	default		
32 alarm value low	0		
33 alarm value high	0		
34 delay time alarm low	0.0 sec		
35 delay time alarm high	0.0 sec		
36 alarm output	hi_lo		
<b>4 - DISPLAY</b>			
41 function	total		
42 set rate min/max	operator level		
43 backlight	off		
44 backlight alarm	off		
45 brightness	5		
<b>5 - POWER MANAGEMENT</b>			
51 LCD-new	1 sec.		
52 mode	operational		
<b>6 - SENSOR</b>			
61 filter	01 (off)		
62 cut-off %	00.0%		
63 calibrat. low-(0)4mA	default		
64 calibrat. high-20mA	default		
<b>7 - OTHERS</b>			
71 model	F073-A	F073-A	F073-A
72 software version	03.03.____	03.03.____	03.03.____
73 serial number	-----	-----	-----
74 pass code	0000		
75 tagnumber	0000000		

