

PH12 Series
Electrochemical Sensors and Accessories for pH and ORP Measurement



The Foxboro[®] brand PH12 Series Sensors are precision electrochemical sensors that are used with a popular set of mounting accessories to measure pH and ORP. These sensors provide a unique electrode technology in the widely used 12 mm form factor, and provide fast response, long life, and high accuracy and stability. They are rugged, easy-to-use devices particularly well suited for low and high temperature, sanitary, and biocompatibility installations. The low cost construction renders the sensor disposable, and therefore eliminates costly sensor maintenance.

FEATURES

- ▶ Proprietary electrode glass formulations.
- ▶ Double junction reference using Nafion ion barrier.
- ▶ Fast thermal response; <1 minute for 80% step.
- ▶ PEEK or Borosilicate Glass sensor bodies.
- ▶ Variopin connector integral to sensor body.
- ▶ A selection of electrode types offered:
 - For pH measurement: Domed glass electrode to 125 or to 140°C (to 257 or to 284°F); or flat ruggedized glass electrode to 125°C (to 257°F).
 - For ORP measurement: Platinum electrode to 125°C (to 257°F).
 - For combination (simultaneous) pH and ORP measurement: glass and platinum electrodes to 125 or to 140°C (to 257 or to 284°F), depending on glass electrode selected.
- ▶ Sensor length of 120, 225, 360, and 425 mm (4.7, 8.9, 14.2, and 16.7 in) available.
- ▶ Sanitary sensors comply with 3-A Standard 74-xx; also meet FDA food processing industry requirements.
- ▶ Sensors meet the biocompatibility requirements of EN ISO 10993-5 and USP 87.
- ▶ ATC with integral 100 or 1000 Ω platinum RTD.
- ▶ Steam sterilizable and autoclavable. Optional autoclave cap available to protect the variopin connections during the cleansing process.
- ▶ Integral solution ground.
- ▶ Standard Viton process seals; EPDM and Perfluoroelastomer are optional.
- ▶ Integral PG 13.5 connection directly threads into a flanged or NPT process connection accessory.
- ▶ Retraction/Insertion and Ball Valve Insertion assemblies offered to allow insertion and replacement of sensor without shutting down the process.
- ▶ 316L ss, CPVC, or Kynar protective sensor holder assembly with or without electrode guard.
- ▶ Mounting accessories include threaded and Tri-Clamp type sanitary process connections, and NPT, NPT pipe adapter, and flanged process connections. Retraction/Insertion and Ball Valve Insertion assemblies are also offered.

- ▶ Cable strain relief housing accessory optional with Sensor Holder assembly; and provided as standard with the Retraction/Insertion assembly.
- ▶ Other accessories include junction boxes, patch cords, extension cables, raw cable, and flow chambers.

SELECTION OF THREE pH ELECTRODE TYPES FOR APPLICATION VERSATILITY

Invensys has a long history of pH electrode research and development. Proprietary glass formulations are implemented, manufactured, and tested in its electrochemical sensor production facility. For the PH12 sensor family, three electrode choices are offered that provide the best solution for the user's unique application requirements. The pH electrodes offered are a flat membrane glass electrode, and a choice of two domed glass electrodes depending on the temperature limits required. See paragraphs below, and also the pH Electrode Selection Guide in Table 1 for a summary of electrode characteristics in varying application conditions.

Best Performing Flat Membrane Electrode

Most flat membrane pH electrodes are not suitable for high temperature service. Though rugged and useful for abrasive applications, their application range has generally been limited to 80 to 85°C (176 to 185°F) due to the composition of glass employed. At Invensys, extensive research and testing have resulted in a glass formulation capable of being formed into a ruggedized, flat membrane while maintaining excellent performance up to 125°C (257°F). When used with the PEEK body sensor, the flat, ruggedized glass electrode provides a sensor with unprecedented durability in the harshest of applications.

High Temperature Domed Glass Electrode for 140°C (284°F) Service

An enhanced domed glass formulation has been developed for high temperature service. This new formulation is the highest temperature electrode offered by Invensys. It is recommended for very high temperature and/or temperature cycling applications. It is also an excellent choice for applications with high pH and high sodium content.

With an upper temperature rating of 140°C (284°F), this electrode is the best choice for steam sterilizable applications.

Domed Glass Electrode with Very Wide Temperature Performance

Invensys uses a proprietary glass formulation which capitalizes on a very low impedance characteristic. By starting with an electrode with low impedance, the electrode performs exceptionally well at very low temperatures. This particular glass formulation also performs well at high temperatures, up to 125°C (257°F). With a specified temperature range of -25 to +125°C (-13 to +257°F), this electrode provides one of the widest usable ranges of any pH electrode on the market.

pH, ORP, OR COMBINATION pH AND ORP MEASUREMENTS

A selection of electrode types is offered, as follows:

- ▶ pH Measurement, Flat Ruggedized Glass Electrode, 0 to 12 pH; -15 to +125°C (5 to 257°F).
- ▶ pH Measurement, Domed Glass Electrode, 0 to 14 pH; -25 to +125°C (-13 to +257°F) wide temperature range; or 0 to 140°C (32 to 284°F) high temperature rating.
- ▶ ORP Measurement, Platinum Electrode, -25 to +125°C (-13 to 257°F).
- ▶ pH and ORP Combination (and simultaneous) Measurement: 0 to 12 pH and ORP, or 0 to 14 pH and ORP; -15 to +125°C (5 to 257°F), -25 to +125°C (-13 to +257°F), or 0 to 140°C (32 to 284°F), depending on glass electrode selected.

Table 1. pH Electrode Selection Guide

Electrode Description			pH Electrode Application (a)						
Model Code (b)	pH Electrode Type	Process Temp.	Low Temp. Service	Low Ionic Strength	Fastest pH Response	Moderate to High Temp. Service	Temp. Cycling	High pH and High Na	Solids and Abrasives
-1 -A (c)	0 to 14 pH Domed Glass	-25 to +125 °C (d)	A	A	A	B	B	B	NR
-2 -B (c)	0 to 14 pH Domed Glass	0 to +140 °C (e)	NR	B	B	A	A	A	NR
-3 -C (c)	0 to 12 pH Flat Glass	-15 to +125 °C	B	NR	B	B	B	NR	A

- Applications A, B, and NR are as follows, - A = Preferred: Generally considered the best choice. - B = Acceptable: Reasonable life under most conditions. - NR = Not Recommended: Generally considered unsuitable for the application.
- Refer to Model Code for pH and ORP Sensor codes and descriptions.
- For Electrode Codes -A, -B, and -C (pH/ORP combinations), the electrode application is determined by the pH electrode selected. For example, electrode type -A combines a -1 (pH) electrode with a -4 (ORP) electrode, and therefore the recommended application is the same as that for the -1 (pH) electrode.
- Wide temperature range domed glass.
- High temperature domed glass.

SANITARY SENSORS

PH12 Sanitary Sensors comply with 3-A Standard 74-xx for use in dairy product processes. They also comply with FDA requirements for elastomers for use in the food processing industries. The 3-A test certificate can be specified as part of the model code structure of the PH12, and is included with the sensor in the shipment.

These sensors are offered with the following quick-disconnect sanitary process connections; a DN 25 threaded process connection, or a 1-, 1 1/2-, or 2-in Tri-Clamp type process connection. These connections are finished to RA15, or better. The crevice-free sensor construction facilitates CIP operations, and the DN25 and Tri-Clamp type process connections provide ease of sensor installation and removal for conventional applications.

BIOCOMPATIBILITY CERTIFICATION

Foxboro PH12 sensors have been engineered to perform in challenging applications found in biopharmaceutical processes. In addition to their

ability to withstand multiple cycles of sterilization, they are designed to be biocompatible under worst case conditions. Sensors have been tested by an independent laboratory and are certified to be biocompatible according to United States Pharmacopeia & National Formulary (USP 87) and ANSI/AAMI/ISO 10993-5 criteria. The biocompatibility test certificate can be specified as part of the model code structure of the PH12, and is included with the sensor in the shipment. Sensors may be provided either with the biocompatibility certificate alone, or with a combination of certificates for biocompatibility and sanitary service according to 3-A.

LOW COST, BUILT-IN SOLUTION GROUND FOR SENSOR DIAGNOSTICS

Sensor diagnostics are an important part of the asset strategy for pH and ORP measurement systems. Increasingly, the diagnostics available from a pH or ORP sensor are used to predict when a sensor will need maintenance. Other diagnostics are used to identify malfunctions which should be addressed immediately. Sensor diagnostics include

aging glass electrode, fouled reference junction, failed temperature compensation element, and broken glass electrode. Using a unique, electrically conductive plastic solution ground, or in the case of sanitary models a stainless steel solution ground, the PH12 sensor incorporates the diagnostic signals as a standard feature in all models. Unlike competitive sensors which require a separate, costly and cumbersome metallic solution ground contact, the PH12 design provides the functionality built-in as a standard component in a cost effective platform.

DURABLE PEEK SENSOR BODY

PEEK, a thermoplastic material, is selected because of its excellent strength and chemical resistance properties over a wide range of process temperatures and pressures. PEEK material displays excellent chemical resistance to most aqueous solutions of acids, bases, and salts. It is also excellent for most organic solvents. Invensys possesses over 20 years' experience in utilizing PEEK material in electrochemical sensors, the longest of any supplier. Many 12 mm sensors are designed as if they evolved from a laboratory environment, utilizing fragile glass bodies. Invensys with its reputation for delivering the most rugged sensors for process applications, has taken a different approach, one that results in longer service life and better resistance to the rigors of insertion, removal, and handling for cleaning and calibration.

NAFION ION BARRIER TO PROTECT REFERENCE JUNCTION

PH12 sensors utilize a double junction reference electrode design to minimize the effects of contamination of the reference electrolyte with process solution. The external, process wetted reference junction is ceramic material with ultra fine porosity and small surface area. The internal electrolyte is a high temperature gel that resists poisoning. The reference electrode is a silver/silver chloride half cell. The reference electrode is encased in a Nafion ion barrier which allows charge transfer while minimizing poisoning of the electrode and preventing silver ions from migrating to the external junction and causing clogging.

NONMETALLIC WETTED PARTS

For more than 20 years, Invensys has pioneered the use of conductive plastic materials for solution ground contacts in process pH and ORP sensors. In the PH12 Series design, the solution ground is constructed of conductive Kynar, which has excellent chemical resistance. The sensor body is either borosilicate glass or PEEK, and the measuring electrode, reference junction, and process seals are nonmetallic and chemically inert. This results in a sensor design that is immune to attack from most process fluids.

SIMPLE ASSEMBLY WITH MANY PROCESS CONNECTIONS OFFERED

The PH12 sensor can be mounted directly to an ANSI Class 150 flange or NPT mounting accessory. The flange or NPT accessory is easily assembled to the sensor's PG 13.5 thread. An O-Ring process seal with a thrust washer is provided with this installation.

Each sensor can also be provided with a separate protective holder assembly which has integral Tri-Clamp type or DN 25 threaded sanitary connections, or ANSI Class 150 flange, NPT, or pipe adapter process connections. The protective holder assembly is also easily assembled to the sensor.

RETRACTION/INSERTION ASSEMBLY

A Retraction/Insertion assembly is used to install the PH12 sensor in a hot tap/retractable type housing. It permits the sensor to be inserted or removed, under rated pressure and temperature, without shutting down the process. See Mounting Accessories section for further details.

BALL VALVE INSERTION ASSEMBLY

A Ball Valve Insertion assembly together with a retraction chamber and insertion shaft also allows inserting and removing the sensor from the process under rated pressure and temperature. It also allows the operator to purge away hot, pressurized, or hazardous chemicals before opening the assembly and servicing the sensor. Refer to Mounting Accessories section further in this document.

CABLE STRAIN RELIEF HOUSING

A cable strain relief housing is offered for users who require strain relief for the external patch cord connecting to the integral variopin connector on the sensor body. This strain relief housing is provided as standard with the Retraction/Insertion assembly, and optional with the Sensor Holder assembly. It is easily assembled to the Retraction/Insertion assembly or Holder assembly.

OPTIONAL AUTOCLAVE CAP

An autoclave cap screws on to the variopin connector to protect the electrical connections during the sterilization and autoclaving process.

OPERATING, STORAGE, AND TRANSPORTATION CONDITION (a)

Influence	Reference Operating Conditions	Normal Operating Condition Limits (a) (b)	Storage and Transportation Limits
Process Temperature with Electrodes below: <ul style="list-style-type: none"> ▶ Domed Glass (Wide Temp.) (pH) ▶ Domed Glass (High Temp.) (pH) ▶ Flat Ruggedized Glass (pH) ▶ Platinum (ORP) 	<ul style="list-style-type: none"> ▶ 25 ± 3°C (77 ± 5°F) ▶ 25 ± 3°C (77 ± 5°F) ▶ 25 ± 3°C (77 ± 5°F) ▶ 25 ± 3°C (77 ± 5°F) 	<ul style="list-style-type: none"> ▶ -25 and +125°C (-13 and +257°F) ▶ 0 and 140°C (32 and 284°F) ▶ -15 and +125°C (5 and 257°F) ▶ -25 and +125°C (-13 and +257°F) (c) 	Not Applicable
Storage Temperature	Not Applicable	Not Applicable	-5 and +65°C (23 and 149°F)
Process Pressure	0 kPag (0 psig)	-48 and +1034 kPag (-7 and +150 psig)	Not Applicable
Mounting Position	Vertical; with Electrode End Down	Vertical up to ±90°; with Electrode End Downward (d)	Not Applicable
Relative Humidity	50 ±10%	0 and 95%	0 and 95%
Vibration	0.1 “g” (1 m/s ²) Negligible Frequency	1 “g” (10 m/s ²) from 5 to 500 Hz	1.1 “g” (11 m/s ²) from 2.5 to 5 Hz; in a packaged container

- a. The specifications listed in the table apply to all sensor configurations. High temperature limits are valid for intermittent service such as sterilization in a bioreactor. Continuous operation at the maximum temperatures, especially in aggressive solutions, may reduce sensor lifetime.
- b. The temperature limits for combination (pH and ORP) measurement is determined by the glass electrode selected.
- c. The ORP temperature limit is extended up to 140°C (284°F) when used with Electrode Type Code -B (pH/ORP combination measurement).
- d. Orientation of the sensor in any position up to 90° from vertical with the electrode end downward.

NOTE

The pressure-temperature limits of the sensor assembly are listed in the table above. When used with process connection accessories, the pressure-temperature limits are those listed above, or those of the process connection accessory used, whichever is less.

PERFORMANCE SPECIFICATIONS

Electrometric Performance - pH Measurement

Parameter	Electrode Type		
	pH - Domed Glass Wide Temperature Range (a)	pH - Domed Glass High Temperature (b)	pH - Flat Ruggedized Glass
Measuring Range	0 to 14 pH		0 to 12 pH
Electromotive Efficiency	98.5% ±1.5%		
Accuracy and Stability	±0.02 pH/24 hrs		
Electrode Resistance (c)	< 100 M Ω	< 500 M Ω	
Electrometric Response Time (d) (c)	< 15 s, 4 to 10 pH		
Temperature Response Time (e) (c)	< 1 min for 80%		
Sodium Ion Error (c)	< 0.2 pH in 0.5 M Na ⁺ at pH 12.4		< 0.2 pH in 0.5 M Na ⁺ at pH 12.0

- a. Wide temperature domed glass range: -25 to +125°C (-13 to +257°F).
b. High temperature domed glass range: 0 to 140°C (32 to 284°F).
c. Values listed are "as shipped".
d. Response time is the interval of time between the initiation of the input step, and the time at which the output signal first attains 90% of its final steady state value.
e. The measurement is made from 25 to 100°C (77 to 212°F) in a pH 4 solution.

Electrometric Performance - ORP Measurement

Parameter	Performance
Measurement Range	-2000 mV to +2000 mV (a)

- a. The measurement range is limited only by the readout instrument.

Temperature Measurement Performance

Parameter	Temperature Compensation Type RTD	
	100 Ω Platinum RTD; Class B	1000 Ω Platinum RTD; Class B
Temperature Range	-25 to +140°C (-13 to +284°F)	-25 to +140°C (-13 to +284°F)
Accuracy at 25°C ±0.425°C (77°F ±0.77°F)	109.73 Ω ±0.17 Ω	1097.3 Ω ±1.7 Ω
Accuracy at Temperature T (a)	±[(0.30°C) + (0.005) (T)]	

- a. Where T = the measured temperature in °C; and [(°C)(9/5)] + 32 = °F.

FUNCTIONAL SPECIFICATIONS

Measuring Electrode

- ▶ Domed glass or flat ruggedized glass electrode with silver/silver chloride internal electrode for pH measurement.
- ▶ Platinum electrode for ORP measurement.

Reference Electrode

The reference electrode is a silver/silver chloride half cell. This electrode is encased in a Nafion ion barrier which allows charge transfer while also minimizing poisoning of the electrode and preventing silver ions from migrating to the external junction and causing clogging.

Measurement Range

DOMED GLASS ELECTRODE

0 to 14 pH

Flat RUGGEDIZED Glass ELECTRODE

0 to 12 pH

PLATINUM ELECTRODE

The measurement range (mV) is limited only by the readout instrument.

Automatic Temperature Compensation (ATC)

Integral temperature element provides temperature measurement for pH compensation over the full rated temperature range of the pH sensor. The integral temperature elements are:

- ▶ 100 Ω Platinum RTD, or
- ▶ 1000 Ω Platinum RTD

NOTE

Both RTDs are 3-wire type to provide lead length compensation. They can be used with analyzers and transmitters that accept either 2- or 3-wire temperature elements.

Electromagnetic Compatibility

When properly installed per the applicable installation instructions with Foxboro Models 870ITPH and 876PH Transmitters, 875PH Analyzers, applicable Models 873, or other compliant transmitters or analyzers, the PH12 Series sensors comply with the electromagnetic compatibility requirements of European EMC Directive 2004/108/EC by conforming to the following EN and IEC Standards: EN-61326-1, and IEC 61000-4-2 through 61000-4-6.

Solution Temperature Measurement

Solution temperature is measured by the RTD. The Resistance-Temperature response is per DIN EN 60751, or IEC 751, and is as follows:

Solution Temperature		Corresponding Resistance in ohms using the:	
°C	°F	100 ohm Platinum RTD	1000 ohm Platinum RTD
-30	-22	88.222	882.22
-20	-4	92.160	921.60
-10	14	96.086	960.86
0	32	100.00	1000.0
10	50	103.90	1039.0
20	68	107.79	1077.9
25	77	109.73	1097.3
30	86	111.67	1116.7
40	104	115.54	1155.4
50	122	119.40	1194.0
60	140	123.24	1232.4
70	158	127.07	1270.7
80	176	130.89	1308.9
90	194	134.70	1347.0
100	212	138.50	1385.0
110	230	142.28	1422.8
120	248	146.06	1460.6
130	266	149.82	1498.2
140	284	153.57	1535.7

ELECTRICAL SAFETY SPECIFICATIONS

The PH12 Sensor meets the requirements of a simple apparatus. A simple apparatus may be defined as an electrical component (or combination of components) of simple construction with well-defined electrical parameters which does not generate more than 1.5 V, 100 mA, and 25 mW, or a passive component which does not dissipate more

than 1.3 W. Certification to the ATEX directive is not required because of the low levels of energy which are added to the intrinsically safe circuit by this apparatus. When connected to an intrinsically safe pH/ORP transmitter, such as a Foxboro Model 870ITPH or 876PH, the PH12 sensor can be installed in a Division 1 or Zone 0 hazardous area.

PHYSICAL SPECIFICATIONS

Electrodes

MEASURING ELECTRODE

- ▶ pH Measurement: Domed or flat glass
- ▶ ORP Measurement: Platinum

Internal electrode is silver wire coated with silver chloride.

REFERENCE ELECTRODE

Internal electrode is silver wire coated with silver chloride (inside a Nafion ion barrier).

Perfluoroelastomer are optional.

Reference Electrolyte

Gelled Electrolyte

Process Connector

Valox

Thrust Washer

Glass filled (25%) ptfе

Sensor Parts

See Figure 1 and descriptions that follow.

Process Wetted Parts

Sensor Body

PEEK or Borosilicate Glass.

Sensitive Membrane

- ▶ pH Measurement: Glass
- ▶ ORP Measurement: Platinum

Reference Junction

Ceramic

Solution Ground

- ▶ pH or ORP Measurement: Conductive Kynar (nonmetallic), or stainless steel (option -S).
- ▶ pH/ORP Combination Measurement: Platinum

Process O-RING AND ELECTRODE Seal

Viton is standard; EPDM and

Figure 1. Sensor Parts (pH Sensor shown)

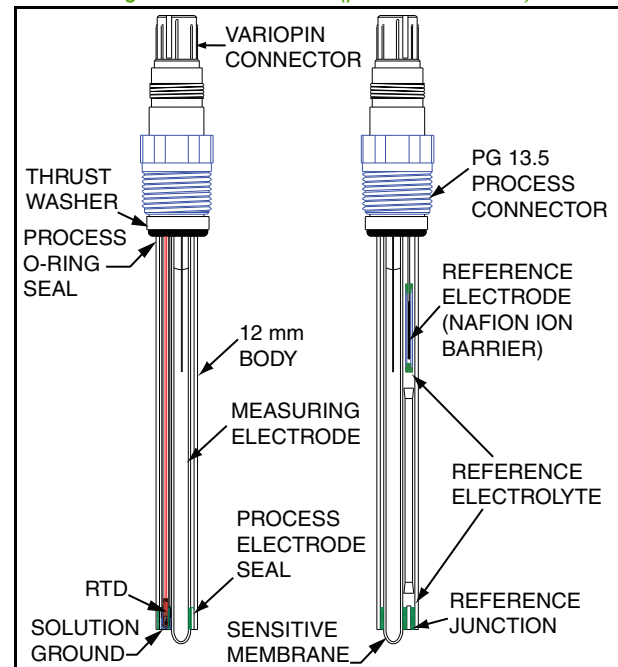

Variopin Connector

Integral to sensor. Contacts are 2 µm gold over nickel plate. Plug head is PEEK with a polyphenylene sulfide insert. Connector meets the ingress protection of IP66/68 per IEC 60529. IP68 immersion is at a depth of 2 m (6.6 ft) for 48 hours.

Measuring Electrodes Configuration

Figure 2 shows the location of the measuring electrode(s) at the bottom surface of the sensor. The configurations shown are for a pH measurement, an ORP measurement, and a pH/ORP combination measurement. Also shown is the location of the reference junction and solution ground.

Figure 2. Measuring Electrode Configuration at Bottom Surface of Sensor.

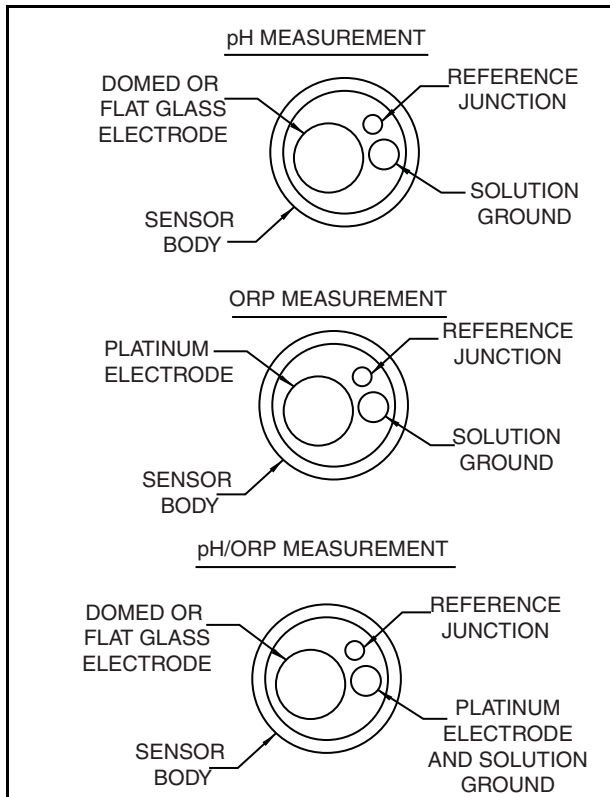

Sensor Mounting

SENSOR WITHOUT PROTECTIVE HOLDER ASSEMBLY

Sensor can be mounted to the process with NPT or ANSI Class 150 process connection accessories. These accessories are easily assembled to the sensor's PG13.5 threads. See Sensor Mounting Accessories Model Code Selection -3. Also see Figure 5 (A and C).

SENSOR WITH protective HOLDER ASSEMBLY

Sensor can be installed into a holder assembly that either has a guard or no guard. The selection of NPT, NPT pipe adapter, ANSI Class 150 flange, DN 25 thread, or Tri-Clamp type process connections are offered. These process connections are integral to the holder assembly, and the holder assembly is easily assembled to the sensor's PG13.5 threads. See Sensor Mounting Accessories Model Code Selections -1 and -2. Also see Figure 5 (B, D, F, G, and H).

Sensor Assembly Configurations

Refer to Figure 3, Figure 4, and Figure 5 for typical sensor assembly configurations. Also refer to MOUNTING ACCESSORIES section.

NOTE

The sensors shown in Figure 3, Figure 4, and Figure 5 show glass electrodes on the bottom surface for pH measurement. Refer to Figure 2 for electrode configurations on the bottom surface of the sensor for pH, ORP, or pH/ORP combination measurements.

Dimensions

Refer to DIMENSIONS-NOMINAL section, and also to Dimensional Print DP 611-214 for additional dimensional information.

Figure 3. Sensor with Flat Glass or Platinum Electrode, and Domed Glass Electrode (No Protective Holder Assembly)

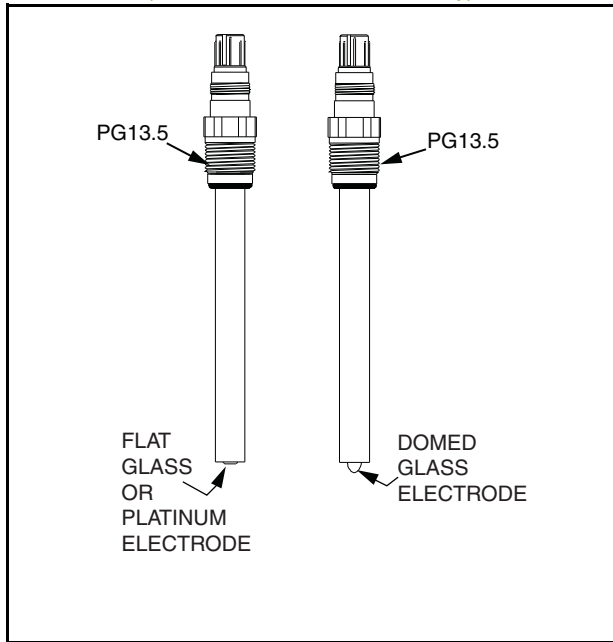

Figure 4. Sensor with Guarded and Unguarded Protective Holder Assembly (shown with Tri-Clamp Type Process Connection)

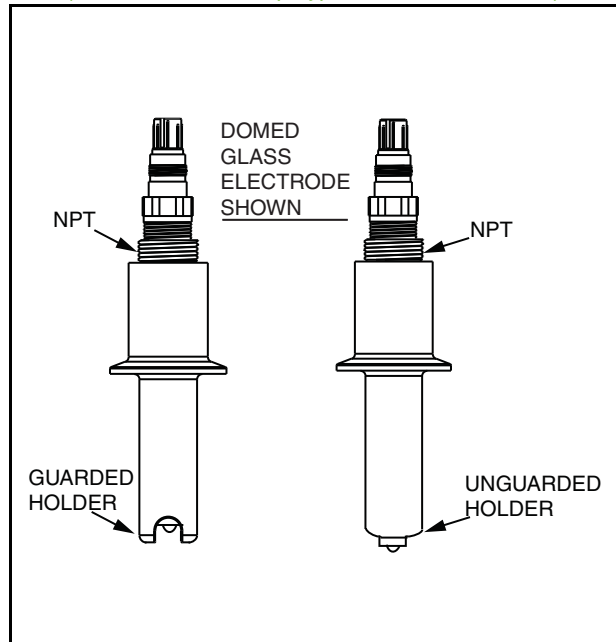
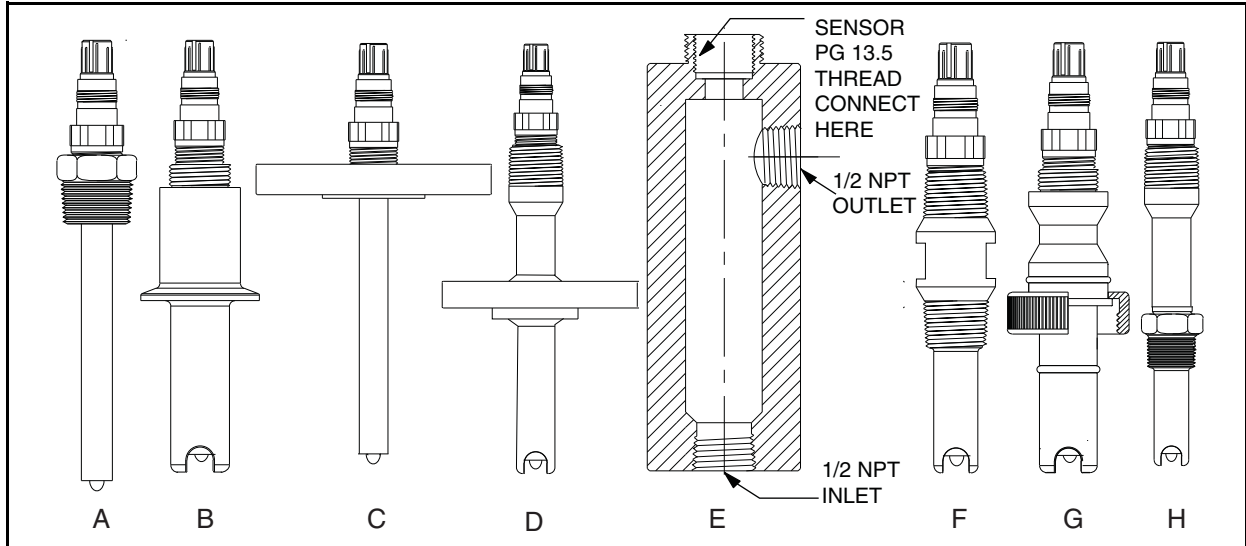

Figure 5. Typical Sensor Assembly and Flow Chamber Configurations (see Descriptions below)



- A = No Holder; Domed Glass (pH); NPT Connection
- B = Guarded Holder; Domed Glass (pH); Tri-Clamp Type Sanitary Connection
- C = No Holder, Domed Glass (pH); Flanged Connection
- D = Guarded Holder, Domed Glass (pH); Flanged Connection
- E = Flow Chamber showing PG 13.5 Sensor Connection, and Inlet/Outlet Connections
- F = Guarded Holder, Domed Glass (pH); NPT Pipe Adapter Connection
- G = Guarded Holder, Domed Glass (pH); DN 25 Threaded Sanitary Connection
- H = Guarded Holder, Domed Glass (pH); NPT Connection

NOTE

The sensor assembly configurations shown in Figure 5 are with a domed glass electrode for pH measurement and a guarded protective holder, except configurations A, C, and E which are not offered with holder assemblies. These same configurations are also available with a flat glass electrode for pH measurement, a platinum

electrode for ORP measurement, and a glass and platinum electrode for pH/ORP combination measurement. The sensor assembly configurations shown in Figure 5 are also offered with an unguarded protective holder (except configurations A, C, and E). Refer to the Model Codes section for sensor assembly configurations offered.

MOUNTING ACCESSORIES

(Selectable from Model FIT12 Mounting Accessories Model Code)

Sensor without Protective Holder Accessory Model FIT12-3

A Model PH12 sensor can be installed without a protective holder accessory, in which case it is connected directly to the process using an ANSI Class 150 flange or NPT process connection mounting accessory. The sensor attaches to the flange or NPT mounting accessory using the PG 13.5 external threads located at the nonimmersible end of the sensor. See Figure 6.

Another selection available with the no holder configuration is the process connection material of the flange or NPT accessory, either 316L ss, CPVC, or Kynar. See FIT12 Mounting Accessories Model Code.

NOTE

A Sensor Model (Model PH12) and Mounting Accessories Model (Model FIT12) must be specified separately. A sensor without a "Protective Holder Accessory" is shown in Figure 6 and is connected to the process with a flange or NPT process connection.

Figure 6. Sensor without Holder;
with Flanged and NPT Process Connection

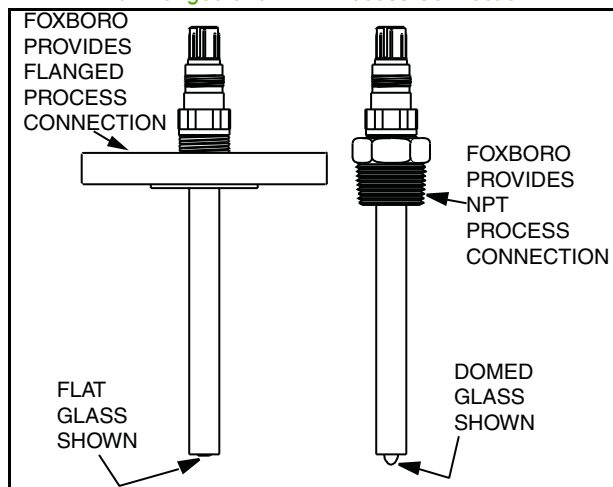

Sensor with Protective Holder Accessory Models FIT12-1 and FIT12-2

A Model PH12 sensor can also be provided with a protective holder. Numerous configurations are available when a protective holder is selected. See paragraphs below and Figure 7.

- ▶ Holder can either have a guard (generally selected with domed glass electrode), or have no guard (generally selected with flat glass or platinum electrode).
- ▶ The process connection can be as follows:
 - DN 25 Threaded Sanitary Connection
 - 3/4-, 1-, 1 1/2-, 2-, 3-, and 4-in Class 150 Flange
 - 3/4- or 1-in NPT
 - 3/4- or 1-in NPT Pipe Adapter
 - 1-, 1 1/2-, or 2-in Tri-Clamp Type Sanitary Connection
- ▶ The immersion length allowed can vary from 25 to 375 mm (1 to 14.8 in). See FIT12 Mounting Accessories Model Code.
- ▶ The holder material is 316L ss, CPVC, or Kynar.
- ▶ The holder to sensor O-Ring seal is Viton; or optionally EPDM, Chemraz, Kalrez, or Perfluoroelastomer (FFKM).
- ▶ And optionally, a cable strain relief housing can be attached to the holder itself. Refer to Figure 8 for a strain relief housing assembled to a sensor assembly with a holder. Also refer to DIMENSIONS-NOMINAL section.

Figure 7. Sensor with Various Holder Configurations

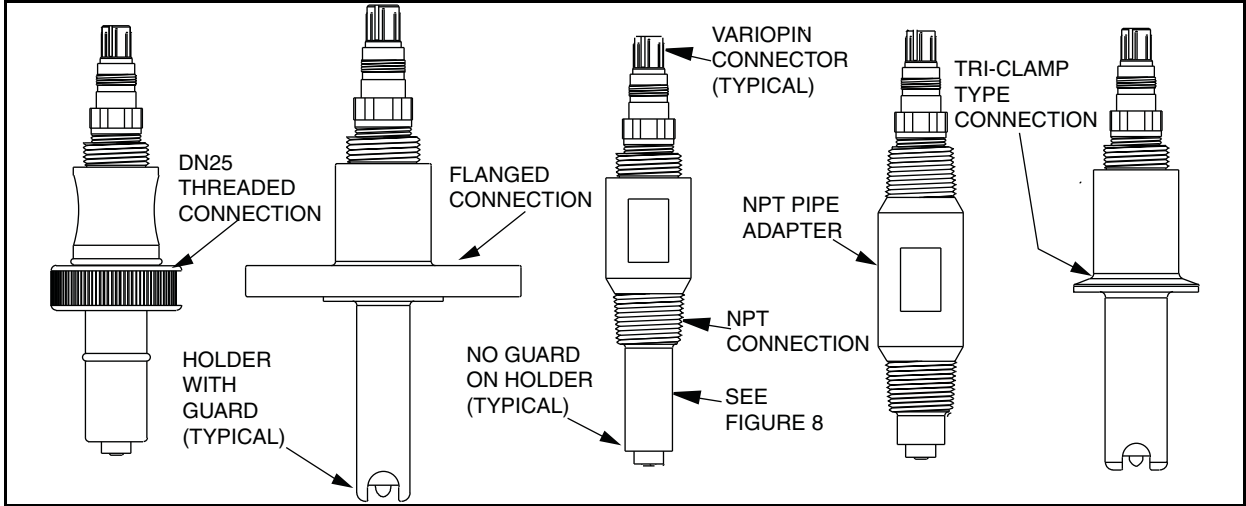
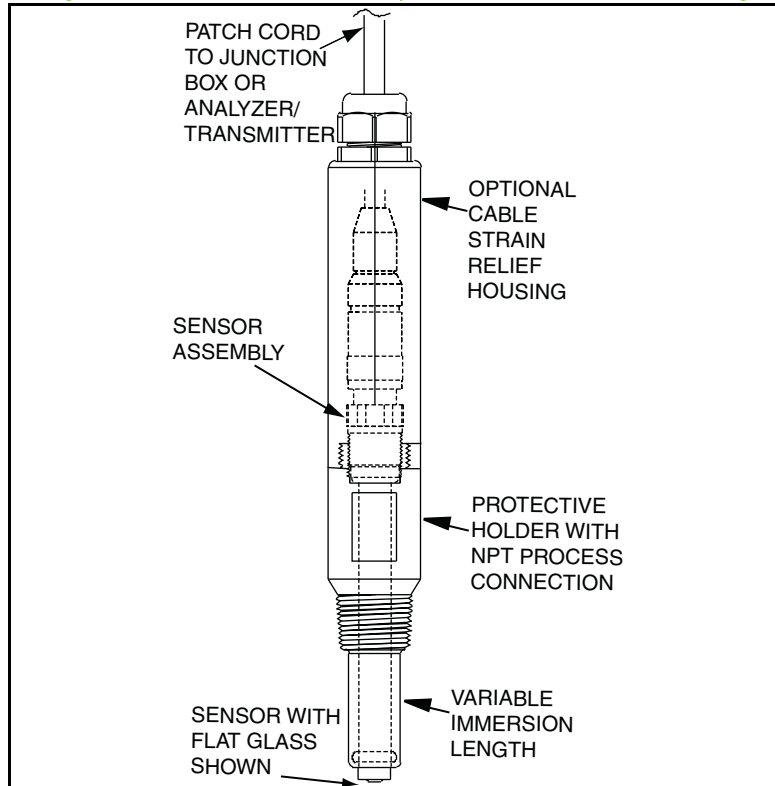

Figure 8. Sensor with Holder and Optional Cable Strain Relief Housing



Retraction/Insertion Assembly

A Retraction/Insertion assembly is used to install the PH12 Sensor in a hot tap/retractable type mounting. It permits the sensor to be inserted into and removed from the installation, under rated pressure and temperature, without shutting down the process, draining the tank, or using a bypass system. A Retraction/Insertion assembly allows a continuously adjustable sensor immersion depth of 0 to 40, 0 to 145, 0 to 280, or 0 to 346 mm (0 to 1.6, 0 to 5.7, 0 to 11.0, or 0 to 13.6 in) depending on the sensor length and Retraction/Insertion assembly selected. This assembly uses a sensor compression seal fully tested to the rated pressure and temperature. The compression seal comprises a ferrule, process connector, O-rings, and a tube nut.

A tube plug is also provided to contain the sensor (blowout protection). A cable strain relief housing is also provided as standard with this assembly.

The Retraction/Insertion assembly is offered in 316L ss, Titanium, CPVC, or Kynar material. Process O-Ring seals (4) are Viton as standard, and optionally EPDM, Chemraz, Kalrez, or Perfluoroelastomer (FFKM). Process connections can be either 1, 1 1/4, or 1 1/2 NPT, and the threads for the cable strain relief housing are 3/4 NPSM. An alignment groove is provided to align the sensor into the insertion assembly. The alignment groove provides a visual reference as to the position of the sensor when inserted into the process. Refer to Figure 9 and to the Dimensions-Nominal section.

Figure 9. Retraction/Insertion Assembly

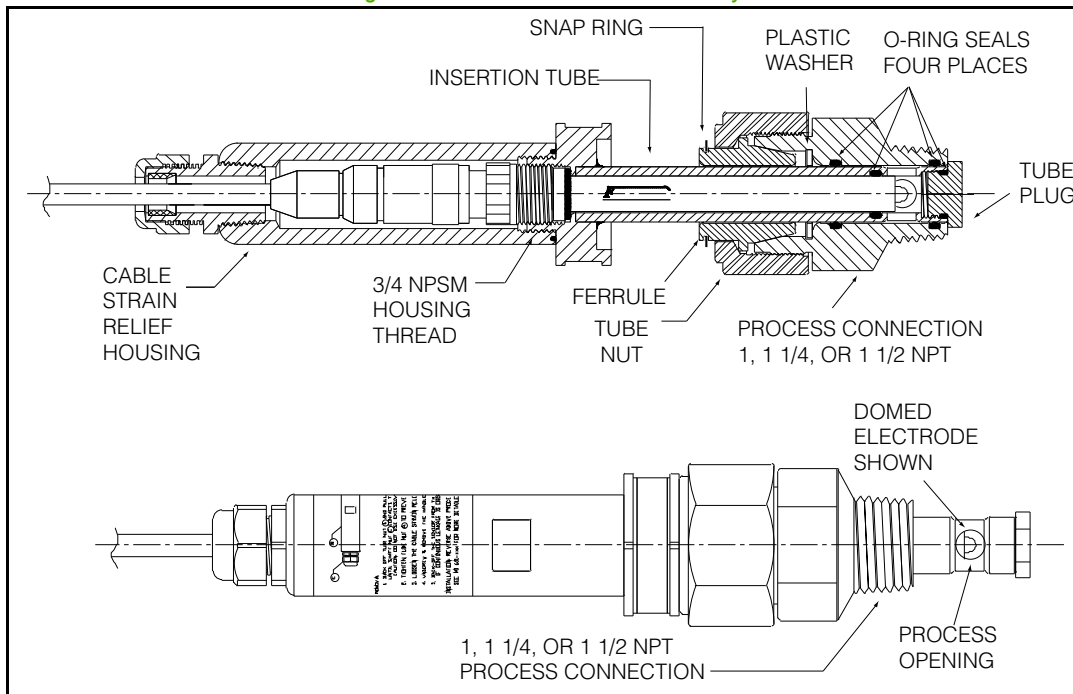

BALL VALVE INSERTION ASSEMBLY

The Ball Valve Insertion assembly is used to install a 120 mm (4.7 in) long PH12 sensor into a hot tap/retractable type mounting. It permits the sensor to be inserted and removed from the process under rated pressure and temperature without draining the tank, shutting down a line, or using a bypass system. It allows a continuously adjustable immersion depth up to the full length of the Ball Valve Insertion shaft. It also allows the installer to locate the sensing end of the PH12 probe at the optimum location for the application, and allows adjustment of the immersion length in response to unexpected plumbing or hardware installation.

The Ball Valve Insertion assembly provides anti-blowout protection, and also provides purge ports on the retraction chamber as a safety feature. These ports allow the operator to purge away hot, pressurized or hazardous chemicals prior to opening the assembly and servicing the sensor. A sealing feature also prevents the process fluid from migrating out through the shaft, and possibly out the cable conduit to the transmitter.

Other features include a push/pull plate for easy movement of the insertion shaft, and simple access to, and removal of the sensor without losing parts.

This Ball Valve Insertion assembly is one of the most effective, safe, and versatile means of installing and replacing a PH12 sensor. Refer to Table 2 and Figure 10.

Table 2. Ball Valve Insertion Assembly Description

PH12 Sensor Length	Ball Valve Insertion Assembly Description			
	Insertion Length	Ball Valve Material	O-Ring Material	Process Connection
120 mm (4.7 in)	0 to 20 cm (0 to 8 in) 0 to 40 cm (0 to 16 in) 0 to 60 cm (0 to 24 in) 0 to 80 cm (0 to 32 in) 0 to xx Length per Sales Order (a)	316 ss, or Titanium	Viton, EPDM, Chemraz, Kalrez or Perfluoroelastomer (FFKM)	1 1/4 NPT
	0 to 40 cm (0 to 16 in)			

a. Contact Invensys

Figure 10. Ball Valve Insertion Assembly

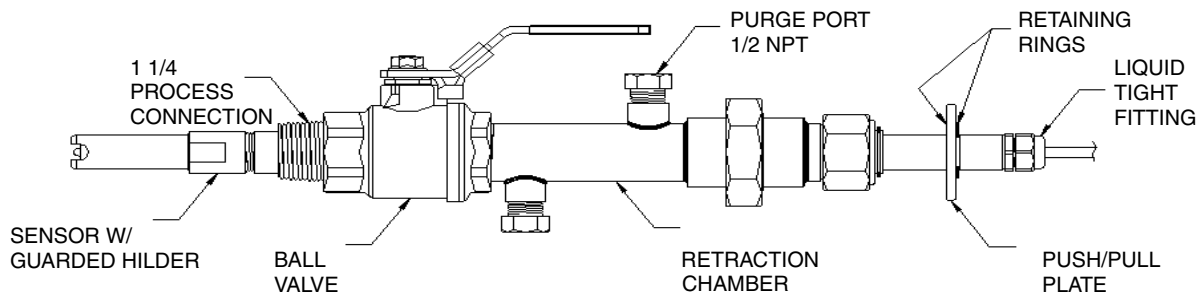

Temperature-Pressure Ratings of Mounting Accessories (Tables 3 to 6)

Table 3 shows the ratings of the Retraction/Insertion Assembly and Ball Valve Insertion assembly accessories with 316L ss and Titanium material.

Table 4 shows the ratings of the Retraction/Insertion assembly with CPVC and Kynar material.

Table 5 shows the ratings of the Flange, NPT, and NPT Pipe Adapter, and DN 25 accessories with 316L ss material.

Table 6 shows the ratings of the Flange, NPT, and NPT Pipe Adapter accessories with CPVC and Kynar material.

For the Tri-Clamp type Sanitary Connection (not shown), the temperature-pressure rating is determined by the user's mating clamp and gasket used. Use the sensor's rating or the Tri-Clamp/gasket rating, whichever is less. Also note that the ratings in Tables 3 to 6 may exceed the ratings of the sensor itself. However use the ratings in the tables or the sensor rating, whichever is less.

Table 3. Temperature-Pressure Ratings of Retraction/Insertion Assembly and Ball Valve Insertion Assembly with 316L ss and Titanium Material

Process Temperature		Maximum Working Pressure of Retraction/Insertion Assembly and Ball Valve Insertion Assembly			
		with 316L ss Material		with Titanium Material	
°C	°F	MPa	psi	MPa	psi
-29 to +66	-20 to +150	1.59	230	1.90	275
93	200	1.35	195	1.72	250
121	250	1.28	185	1.65	240
149	300	1.21	175	1.59	230

Table 4. Temperature-Pressure Ratings of Retraction/Insertion Assembly with CPVC or Kynar Material

Process Temperature		Maximum Working Pressure of Retraction/Insertion Assembly			
		CPVC Material		Kynar Material	
°C	°F	KPa	psi	KPa	psi
-30 to +21	-22 to +70	1034	150	1034	150
27	80	993	144	979	143
49	120	724	105	703	102
71	160	414	60	510	74
82	180	262	38	434	63
93	200	186	27	372	54
99	210	159	23	345	50
116	240	-	-	262	38

NOTE

See WARNING on Next Page.

Table 5. Temperature-Pressure Ratings of Flange, NPT, NPT Pipe Adapter, and DN 25 Accessories with 316L ss Material

Process Temperature		Maximum Working Pressure of Flange, NPT, NPT Pipe Adapter, and DN 25 Accessory			
		316L ss Flange Accessory (a)		316L ss, 3/4 and 1 NPT, NPT Pipe Adapter and DN 25 Accessory (b)	
°C	°F	MPa	psi	MPa	psi
-29 to +66	-20 to +150	1.59	230	20.7	3000
93	200	1.35	195	20.7	3000
121	250	1.28	185	20.7	3000
149	300	1.21	175	20.7	3000

- a. Flange applies to Process Connection Accessory Code F* (ANSI Class 150 Flange).
- b. NPT applies to Process Connection Accessory Code N* (NPT), and NPT Pipe Adapter applies to Process Connection Code S* (NPT Pipe Adapter), and DN 25 applies to Process Connection Code DA (DN 25 Threaded Sanitary Connection).

Table 6. Temperature-Pressure Ratings of Flange, NPT, and NPT Pipe Adapter Accessories with CPVC or Kynar Material

Process Temperature		Maximum Working Pressure of Flange, NPT, or NPT Pipe Adapter Accessory											
		CPVC Material						Kynar Material					
		Flange (a)		3/4 NPT (b)		1 NPT (b)		Flange (a)		3/4 NPT (b)		1 NPT (b)	
°C	°F	kPa	psi	kPa	psi	kPa	psi	kPa	psi	kPa	psi	kPa	psi
-30 to +21	-22 to +70	1034	150	2344	340	2206	320	1034	150	1586	230	1448	210
27	80	993	144	2277	326	2117	307	979	143	1510	219	1379	200
38	100	883	128	1993	289	1875	272	827	120	1269	184	1158	168
49	120	724	105	1641	238	1544	224	703	102	1076	156	979	143
60	140	572	83	1289	187	1214	176	600	87	917	133	841	122
71	160	414	60	938	136	883	128	510	74	779	113	703	103
82	180	262	38	586	85	552	80	434	63	669	97	607	88
93	200	186	27	421	61	400	58	372	54	572	83	524	76
99	210	159	23	352	51	331	48	345	50	524	76	476	69
116	240	-	-	-	-	-	-	262	38	400	58	365	53

- a. Flange applies to Process Connection Accessory Code F* (ANSI Class 150 Flange).
- b. NPT applies to both the Process Connection Accessory Code N* (NPT) and Process Connection Accessory Code S* (NPT Pipe Adapter).

WARNING

For CPVC or Kynar accessories (Table 4 and Table 6) pressure spikes/surges, water hammer, and impact should be avoided since these effects can be detrimental as the plastic becomes brittle at temperatures below -18°C (0°F).

WIRING ACCESSORIES
(Selectable by Part Number - see Tables 7 to 10)

Wiring

Patch cords are required for use with the sensor. The patch cord lengths offered are 10, 20, 30, 40, or 50 feet, and temperature limits are 80°C (176°F) for a standard temperature cord, or 125°C (257°F) for a high temperature cord. The patch cord has a Variopin connector on the sensor end and straight pin lugs on the other end which connect either directly to the analyzer or transmitter, a junction box with no amplifier, or a junction box with an amplifier. See Figures 11 and 12.

Extension cables with straight pin lugs on both ends are offered as follows:

- ▶ In lengths from 10 to 40 feet when no amplifier is used in the junction box. Temperature limits are 80 or 125°C. Refer to Figures 11 and 13.
- ▶ In lengths from 10 to 490 feet when an amplifier is used in the junction box. Temperature limits are 80°C. Refer to Figures 11 and 13.

Raw, unterminated cable is also offered in continuous lengths up to 1000 feet. The user must cut the cable to the required length, and add his own terminals. This cable has temperature limits of 80 or 125°C. See Figure .

For patch cord, extension cable and raw cable specifications and part numbers, see Tables 7 to 10.

Junction Boxes

JUNCTION BOX WITH NO AMPLIFIER

This is a cast aluminum, surface-mounted enclosure with a neoprene gasket. It houses an encapsulated terminal block assembly with two blocks having seven terminals each. One block is for the patch cord from the sensor assembly, and the second block is for the extension cable connecting to the transmitter or analyzer. Sufficient space is provided to allow for patch cord and extension cable terminations. The enclosure is 160 x 102 x 81 mm (6.3 x 4.0 x 3.2 in) in size, and provides the dusttight, weatherproof, and corrosion resistant protection rating of NEMA 4X. Specify Part Number BS813XN. See Figures 11 and 15.

JUNCTION BOX WITH AN AMPLIFIER

This is the same enclosure as that for the junction box with no amplifier. The only two differences are as follows:

1. The encapsulated terminal block assembly incorporates an amplifier assembly.
2. One terminal block has seven terminals for the patch cord, and the second terminal block has terminals to accommodate the nine-conductor extension cable. Specify Part Number BS811MR. Refer to Figures 11 and 16.

Figure 11. Patch Cord and Extension Cable Configurations

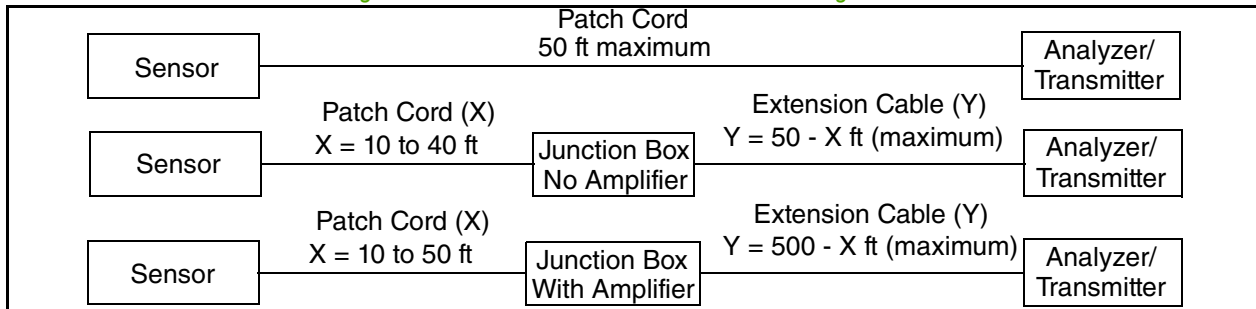

Figure 12. Patch Cord with Variopin Quick Connector and Straight Pin Lugs (see Table 7)

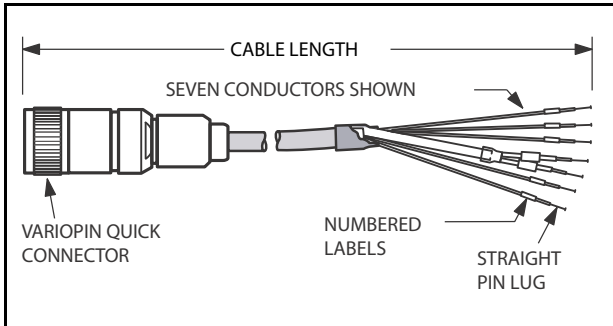

Figure 14. Raw, Unterminated Cable Shown (see Table 10) (Pin Lugs provided by User)

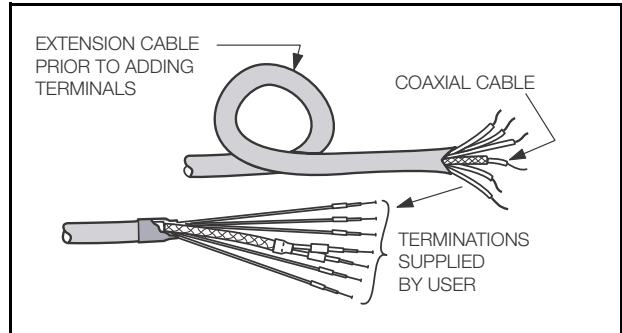

Figure 13. Extension Cable Assembly with Straight Pin Lugs on Both Ends (see Table 8 and Table 9)

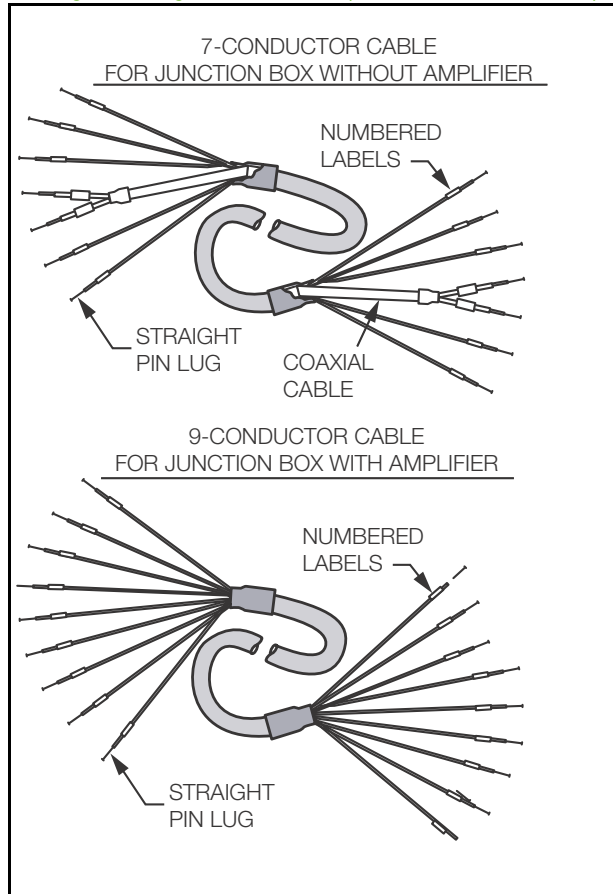

Figure 15. Junction Box with no Amplifier

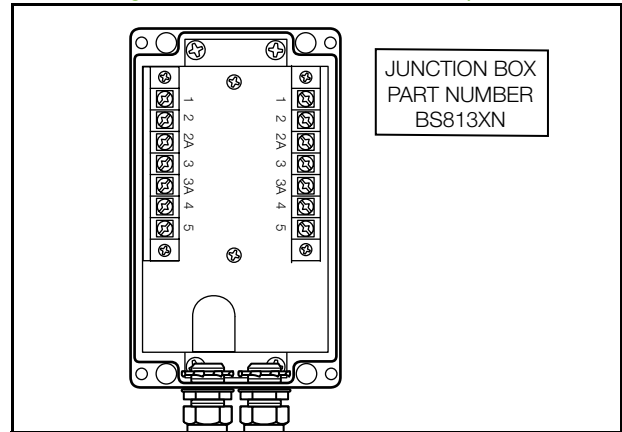

Figure 16. Junction Box with an Amplifier

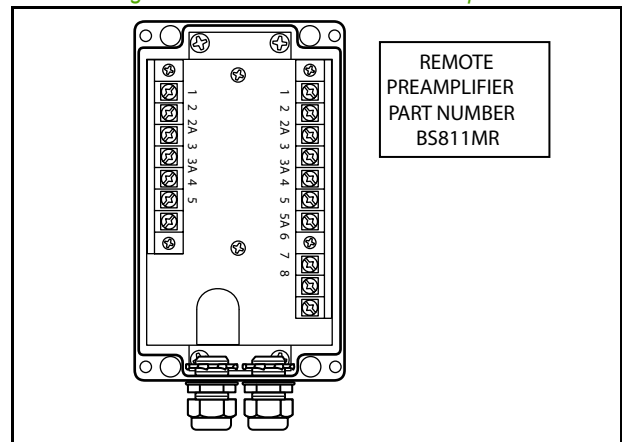

Table 7. Patch Cords

Part No.	Temperature Range	Cable Terminations	Length (Feet)
BS811GU	Standard (to 80°C)	Variopin to Pin Lugs	10
BS811GV	Standard (to 80°C)	Variopin to Pin Lugs	20
BS811GW	Standard (to 80°C)	Variopin to Pin Lugs	30
BS811GX	Standard (to 80°C)	Variopin to Pin Lugs	40
BS811GY	Standard (to 80°C)	Variopin to Pin Lugs	50
BS810QA	High Temp (to 125°C)	Variopin to Pin Lugs	10
BS810QB	High Temp (to 125°C)	Variopin to Pin Lugs	20
BS810QC	High Temp (to 125°C)	Variopin to Pin Lugs	30
BS810QD	High Temp (to 125°C)	Variopin to Pin Lugs	40
BS810QE	High Temp (to 125°C)	Variopin to Pin Lugs	50

Table 8. Extension Cables for Junction Box without Amplifier

Part No.	Temperature Range	Cable Terminations	Length (Feet)
BS811HE	Standard (to 80°C)	Pin Lugs to Pin Lugs	10
BS811HF	Standard (to 80°C)	Pin Lugs to Pin Lugs	20
BS811HG	Standard (to 80°C)	Pin Lugs to Pin Lugs	30
BS811HH	Standard (to 80°C)	Pin Lugs to Pin Lugs	40
BS810ZV	High Temp (to 125°C)	Pin Lugs to Pin Lugs	10
BS810ZW	High Temp (to 125°C)	Pin Lugs to Pin Lugs	20
BS810ZX	High Temp (to 125°C)	Pin Lugs to Pin Lugs	30
BS810ZY	High Temp (to 125°C)	Pin Lugs to Pin Lugs	40

Table 9. Extension Cable for Junction Box with Amplifier

Part No.	Temperature Range	Cable Terminations	Length (Feet) (a)
BS811HW	Standard (to 80°C)	Pin Lugs to Pin Lugs	490 maximum

a. Available to 490 ft maximum in 1 foot increments.

Table 10. Raw Cable, Unterminated, Maximum Continuous Length is 1000 ft

Part No.	Temperature Range	Cable Terminations	Length (Feet) (a)
P0170UU	Standard (to 80°C) (b)	None (Terminations by User)	1000 maximum
P0170UA	High Temp (to 125°C) (b)	None (Terminations by User)	1000 maximum
P0170UV	Standard (to 80°C) (c)	None (Terminations by User)	1000 maximum

a. Available in continuous lengths to 1000 feet in 1 foot increments.

b. Used with junction box not having an amplifier.

c. Used with junction box that has an amplifier.

Flow Chambers

Flow chambers are used with 120 mm (4.7 in) sensors for mounting in a system where a sample is provided by a small diameter sample line. The inlet and outlet ports of the chamber have 1/2 NPT threads, and connect to the system with user supplied fittings. The chamber is offered in 316L ss, Kynar, or CPVC. See Figure 17 and Table 11.

Figure 17. Flow Chamber and Optional Strain Relief Housing

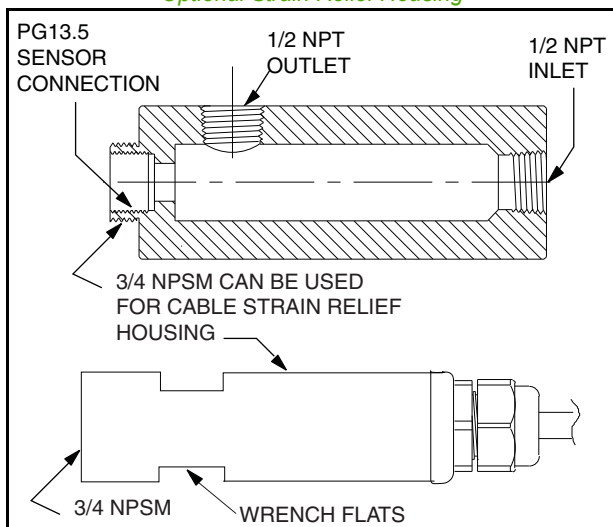

Table 11. Flow Chambers and Optional Strain Relief Housing

Flow Chamber		
Material	Connection to Sensor	Part No.
316L ss	PG 13.5	BS813LA
Kynar	PG 13.5	BS813LB
CPVC	PG 13.5	BS813LC
Optional Strain Relief Housing		
Material	Connection to Chamber	Part No.
Nylon	3/4 NPSM	BS812XU
Flow Chamber Pressure-Temperature Rating (a)		
Material	Pressure-Temperature Rating	
316L ss	1.4 MPa at 140°C (200 psi at 284°F)	
Kynar	0.7 MPa at 90°C (100 psi at 194°F) 0.35 MPa at 125°C (50 psi at 257°F)	
CPVC	0.7 MPa at 70°C (100 psi at 158°F) 0.4 MPa at 85°C (60 psi at 185°F)	

a. The pressure-temperature rating of the flow chamber is as listed. When the sensor is assembled to the chamber, the pressure-temperature limits of the assembled pair are as listed, or are the limits of the sensor itself, whichever is less.

Buffers for use with Model PH12 Sensors

Buffers are available as a solution, or in a salt packet. When provided in a salt packet, the buffer is mixed with 0.47 liters (16 fluid ounces) of distilled water to convert to a buffer solution. Refer to Table 12 for part numbers for Buffer Solutions and Salt Packets.

Table 12. Buffer Solutions and Salt Packets

Type	Buffer Description	Part No.
Buffer Solution	4.00 pH, 0.47 L (16 fl oz)	Q0104KC
	7.00 pH, 0.47 L (16 fl oz)	Q0104KB
	10.00 pH, 0.47 L (16 fl oz)	Q0104KA
Salt Packet	4.00 pH (a)	1600100
	7.00 pH (a)	1600101
	10.00 pH (a)	1600102

a. Mix salt packet with 0.47 L (16 fl oz) of distilled water to convert to solution form.

MODEL CODE: PH12 PH AND ORP SENSOR

Description	Model
PH12 pH and ORP Sensor - 12 mm Diameter, PG 13.5 Process Connection	PH12
Electrode Type	
pH, 0 to 14 pH, Wide Temperature Range Domed Glass, -25 to +125°C (-13 to +257°F)	-1
pH, 0 to 14 pH, High-Temperature Domed Glass, 0 to 140°C (32 to 284°F)	-2
pH, 0 to 12 pH, Flat Ruggedized Glass, -15 to +125°C (5 to 257°F)	-3
ORP, Platinum, -25 to +125°C (-13 to +257°F)	-4
pH/ORP Combination, 0 to 14 pH and ORP, Wide Temperature Range Domed Glass and Platinum, -25 to +125°C (-13 to +257°F)	-A
pH/ORP Combination, 0 to 14 pH and ORP, High-Temp Domed Glass and Platinum, 0 to 140°C (32 to 284°F)	-B
pH/ORP Combination, 0 to 12 pH and ORP, Flat Ruggedized Glass and Platinum, -15 to +125°C (5 to 257°F)	-C
Sensor Body Material	
Glass Body	G
PEEK Body	P
Sensor Length	
120 mm (4.7 in)	1
225 mm (8.4 in) (a)	2
360 mm (14.2 in) (a)	3
425 mm (16.7 in) (a)	4
Temperature Compensation	
100 Ω Platinum RTD, 3-wire (b)	1
1000 Ω Platinum RTD, 3-wire (b)	2
Sensor Termination	
Variopin Quick Connector integral to Sensor Body (c)	Q
Optional Selection	
Autoclave Cap (d)	-A
Biocompatibility	-B
EPDM Process O-Ring Seal and Process Electrode Seal (see Figure 1) (e)	-E
Detailed Instruction Manual (f)	-M
Perfluoroelastomer (FFKM) O-Ring & Process Seal (f)	-P
3-A Compliant (g) (h)	-S
Example: PH12-3G12Q-E; PH12-2G21Q-MS	

- a. Not available with Glass Body Sensor — G, Electrode Measurement and Type -4.
- b. Compatible with Analyzers and Transmitters that accept either 2-wire or 3-wire temperature elements.
- c. A mating Patch Cord with an integral Variopin Quick Connector on one end is required. Refer to the WIRING ACCESSORIES section for a selection of Patch Cords and extension cables offered.
- d. Autoclave cap protects the variopin connections during steam sterilization and autoclaving. The cap is shipped separate from the sensor.
- e. The standard process seals are Viton.
- f. A DVD and a “Quick-Start” pamphlet are shipped as standard with each sensor.
- g. Electrode Type Codes -1, -2, -3, and -4, when used with option -S, use a stainless steel solution ground.
- h. Not available with Optional Selection code "-P" Perfluoroelastomer O-Ring and Seal.

MODEL CODE: FIT12 MOUNTING ACCESSORIES

<u>Description</u>	<u>Model</u>
Mounting Accessories for PH12 Sensor	FIT12
Sensor Holder/Protection	
Mounting Assembly for PH12 Sensor Holder - includes Protective Guarded Holder (a)	-1
Mounting Assembly for PH12 Sensor Holder - includes Protective Unguarded Holder	-2
Mounting Assembly for PH12 Sensor without Holder;	-3
For use with Process Connection Codes F* and N* only; cannot be configured with optional selections (cable strain relief housing or O-rings).	
<u>Process Connection</u>	
DN 25 Threaded Type Sanitary Connection (b) (c)	DA
3/4 in ANSI Class 150 Flange Connection	FA
1 in ANSI Class 150 Flange Connection	FB
1 1/2 in ANSI Class 150 Flange Connection	FC
2 in ANSI Class 150 Flange Connection	FD
3 in ANSI Class 150 Flange Connection	FF
4 in ANSI Class 150 Flange Connection	FH
3/4 NPT Connection	NA
1 NPT Connection	NB
1 NPT Adjustable Retraction/Insertion Assembly (a)	RB
1 1/4 NPT Adjustable Retraction/Insertion Assembly (a)	RJ
1 1/2 NPT Adjustable Retraction/Insertion Assembly (a)	RC
3/4 NPT Pipe Adapter (d)	SA
1 NPT Pipe Adapter (d)	SB
1 in Tri-Clamp Type Sanitary Connection (b) (c)	TB
1 1/2 in Tri-Clamp Type Sanitary Connection (b) (c)	TC
2 in Tri-Clamp Type Sanitary Connection (b) (c)	TD
<u>Immersion Length (e)</u>	
Immersion Length dictated by Electrode; select with Sensor Holder Code -3 only.	000
25 mm (1 in) Immersion Length (f)	025
33 mm (1.3 in) Immersion Length (f)	033
40 mm (1.6 in) Immersion Length (g)	040
70 mm (2.8 in) Immersion Length	070
100 mm (4.0 in) Immersion Length	100
150 mm (5.9 in) Immersion Length (g)	150
175 mm (6.9 in) Immersion Length	175
200 mm (7.9 in) Immersion Length	200
275 mm (10.8 in) Immersion Length (g)	275
375 mm (14.8 in) Immersion Length (g)	375
<u>Holder and/or Process Connection Material</u>	
316L ss	L
CPVC	C
Kynar	K
Titanium (h)	T

MODEL CODE: FIT12 MOUNTING ACCESSORIES (CONTINUED)

Optional Selections	
Cable Strain Relief Housing (i)	-1
EPDM O-Rings (j) (k) (l)	-E
Chemraz O-Rings (j) (k) (l)	-C
Kalrez O-Rings (j) (k) (l)	-K
Perfluoroelastomer (FFKM) O-Rings (j) (k) (l)	-P
Examples: FIT12-1FB040L-1E; FIT12-3NA000L; FIT12-1RB150T-E	

- a. Process Connection Codes RB, RJ, and RC are only available with Sensor Holder Code -1.
- b. Available with Holder Material Code L (316L ss) only.
- c. All Sanitary Process Connections are RA15, or better.
- d. Pipe adapters have NPT threads on both ends. Only available with Immersion Length Codes 040 and 070.
- e. See Table 13 for allowable combinations of Sensor Codes, Sensor Lengths, and Immersion Lengths.
- f. Immersion Length Codes 025 and 033 are not available with Process Connection Code -DA (DN 25 Connection).
- g. See Table 14 for allowable combination of Sensor Holder Code FIT12 -1R*, Sensor Length, and Immersion Lengths.
- h. Holder Material Code T (Titanium) is only available with Model Code Selections FIT12-1RB, FIT12-1RJ, and FIT12-1RC.
- i. Optional Cable strain relief housing is only offered with Sensor Holder Codes -1 and -2. It is provided as standard with Process Connection Codes RB, RJ, and RC.
- j. Standard O-Ring material is Viton.
- k. Either -E, -C, -K or -P may be selected individually. However, only one of these choices may be selected.
- l. O-rings are only offered with Sensor Holder Codes -1 and -2.

Table 13. Allowable Combination of Sensor Codes, Sensor Lengths, and Immersion Lengths

Sensor Code	Sensor Length	FIT12 Immersion Code and Length	
		Code	Immersion Length
PH12-**1	120 mm (4.7 in)	025	25 mm (1 in)
	120 mm (4.7 in)	033	33 mm (1.3 in)
	120 mm (4.7 in)	040	40 mm (1.6 in)
	120 mm (4.7 in)	070	70 mm (2.8 in)
PH12-**2	225 mm (8.9 in)	100	100 mm (4.0 in)
	225 mm (8.9 in)	150	150 mm (5.9 in)
	225 mm (8.9 in)	175	175 mm (6.9 in)
PH12-**3	360 mm (14.2 in)	200	200 mm (7.9 in)
	360 mm (14.2 in)	275	275 mm (10.8 in)
PH12-**4	425 mm (16.7 in)	375	375 mm (14.8 in)

Table 14. Allowable Combination of Sensor Holder Code FIT12- 1R*, Sensor Length, and Immersion Length

Sensor Holder Code	Sensor Code and Length		Immersion Code and Immersion and Adjustable Length		
	Code	Length	Code	Immersion Length	Adjustable Length
FIT12-1R*	PH12-**1	120 mm (4.7 in)	040	40 mm (1.6 in)	0 to 40 mm (0 to 1.6 in)
	PH12-**2	225 mm (8.9 in)	150	150 mm (5.9 in)	0 to 145 mm (0 to 5.7 in)
	PH12-**3	360 mm (14.2 in)	275	275 mm (10.8 in)	0 to 280 mm (0 to 11.0 in)
	PH12-**4	425 mm (16.7 in)	375	375 mm (14.8 in)	0 to 346 mm (0 to 13.6 in)

MODEL CODE: BALL VALVE INSERTION ASSEMBLY

<u>Description</u>	<u>Model</u>
Ball Valve Insertion Assembly	BVA
Sensor Type For use with PH12 Sensor; 120 mm (4.7 in) long only; 1 1/4 in Full Port Valve (a)	-PHD
<u>Process Wetted Material</u> Stainless Steel 316L Titanium	1 2
<u>O-Ring Material</u> Chemraz O-Rings EPDM O-Rings Kalrez O-Rings Perfluoroelastomer (FFKM) O-Rings Viton O-Rings	C E K P V
<u>Insertion Length</u> 0 – 20 cm (0 to 8 in) includes ball valve and nipple 0 – 40 cm (0 to 16 in) includes ball valve and nipple 0 - 60 cm (0 to 24 in) includes ball valve and nipple 0 - 80 cm (0 to 32 in) includes ball valve and nipple Custom Insertion Length, includes ball valve and nipple 20cm (8 in) increments (b)	08 16 24 32 xx
<u>Optional Selections</u> Insertion Assembly (c) (a) 1½"ANSI 150# Flange 2" ANSI 150# Flange 3" ANSI 150# Flange 4" ANSI 150# Flange Safety Guard (d) Unguarded Holder (a)	-A -C -D -F -H -S -U
Example: BVA-PHD1V08-U	

- a. Standard sensor mounting is Guarded for PH12 Ball Valve Insertion assemblies, Model codes BVA-PHD..., select -U for unguarded sensor mounting.
- b. Contact Invensys, prior approval required.
- c. No valve or nipple supplied.
- d. Not available with Optional Selection -A.

DIMENSIONS - NOMINAL

$\frac{\text{mm}}{\text{in}}$

MODEL PH12 SENSOR WITH NO MOUNTING ACCESSORIES

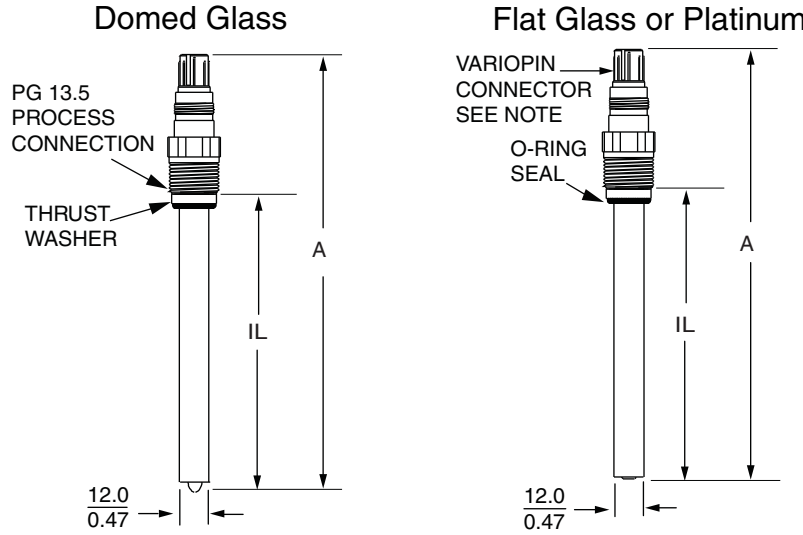

Dimension (a)	Electrode Type	Sensor Length			
		120 mm (4.7 in)	225 mm (8.9 in)	360mm (14.2 in)	425mm (16.7 in)
IL	Domed Glass	120 (4.7)	225 (8.9)	360 (14.2)	425 (16.7)
	Flat Glass or Platinum	117 (4.6)	222 (8.7)	357 (14.1)	422 (16.6)
A	Domed Glass	176 (6.9)	281 (11.1)	416 (16.4)	481 (18.9)
	Flat Glass or Platinum	173 (6.8)	278 (10.9)	413 (16.3)	478 (18.8)

a. IL = Maximum Immersion Length.

NOTE

1. An optional Autoclave Cap (PH12 Sensor Option -A) screws on to the Variopin connector, and protects the Variopin connections during the steam sterilization and autoclaving process. See Optional Autoclave Cap further in this document.
2. Also refer to Dimensional Print DP 611-214.

mm
in

MODEL PH12 SENSOR WITH MODEL FIT12-3 MOUNTING ACCESSORIES

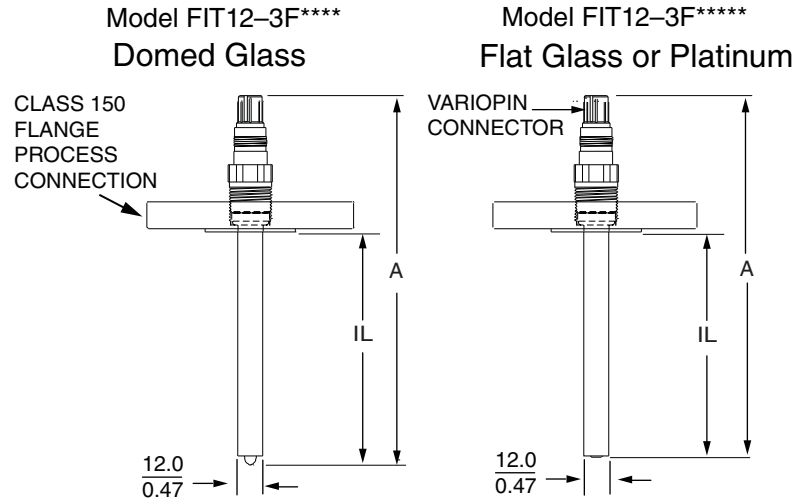

Dimension (a)	Electrode Type	Immersion Length Code (b)	Flange Code	Sensor Length			
				120 mm (4.7 in)	225 mm (8.9 in)	360mm (14.2 in)	425mm (16.7 in)
IL	Domed Glass	000	FA, FB, FC	112 (4.4)	217 (8.5)	352 (13.9)	417 (16.4)
		000	FD	109 (4.3)	206 (8.1)	341 (13.4)	406 (16.0)
		000	FF, FH	104 (4.1)	190 (7.5)	325 (12.8)	390 (15.4)
	Flat Glass or Platinum	000	FA, FB, FC	109 (4.3)	206 (8.1)	341 (13.4)	406 (16.0)
		000	FD	107 (4.2)	201 (7.9)	336 (13.2)	401 (15.8)
		000	FF, FH	102 (4.0)	183 (7.2)	318 (12.5)	383 (15.1)
A	Domed Glass	000	FA, FB, FC, FD, FF, FH	176 (6.9)	281 (11.1)	416 (16.4)	481 (18.9)
	Flat Glass or Platinum	000	FA, FB, FC, FD, FF, FH	173 (6.8)	278 (10.9)	413 (16.3)	478 (18.8)

- a. IL - Maximum Immersion Length.
- b. Immersion Length Code 000 must be selected when no holder assembly is used.

$\frac{\text{mm}}{\text{in}}$

MODEL PH12 SENSOR WITH MODEL FIT12-3 MOUNTING ACCESSORIES

Model FIT12-3N*****
Domed Glass

Model FIT12-3N*****
Flat Glass or Platinum

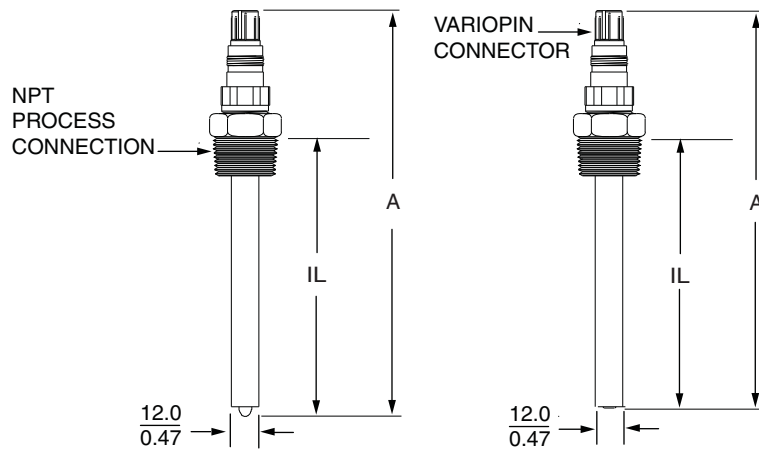

Dimension (a)	Electrode Type	Immersion Length Code (b)	NPT Code	Sensor Length			
				120 mm (4.7 in)	225 mm (8.9 in)	360mm (14.2 in)	425mm (16.7 in)
IL	Domed Glass	000	NA, NB	122 (4.8)	227 (8.9)	362 (14.3)	427 (16.8)
	Flat Glass or Platinum	000	NA, NB	119 (4.7)	224 (8.8)	359 (14.1)	424 (16.7)
A	Domed Glass	000	NA, NB	176 (6.9)	281 (11.1)	416 (16.4)	481 (18.9)
	Flat Glass or Platinum	000	NA, NB	173 (6.8)	278 (10.9)	413 (16.3)	478 (18.8)

- a. IL - Maximum Immersion Length.
- b. Immersion Length Code 000 must be selected when no holder assembly is used.

$\frac{\text{mm}}{\text{in}}$

MODEL PH12 SENSOR WITH MODELS FIT12-1/FIT12-2 MOUNTING ACCESSORIES

Model FIT12-1DA*** - 1
Domed Glass/Guarded

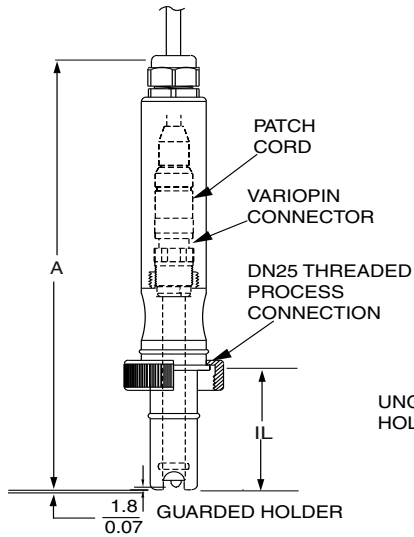

Model FIT12-2DA***L - 1
Domed Glass/Unguarded

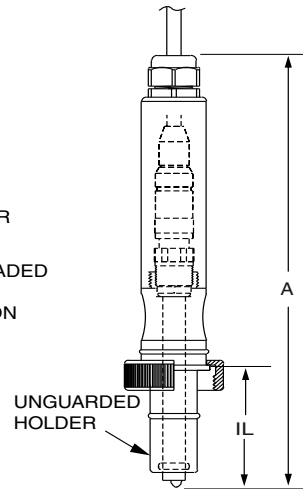

Model FIT12-2DA***L - 1
Flat Electrode/Unguarded

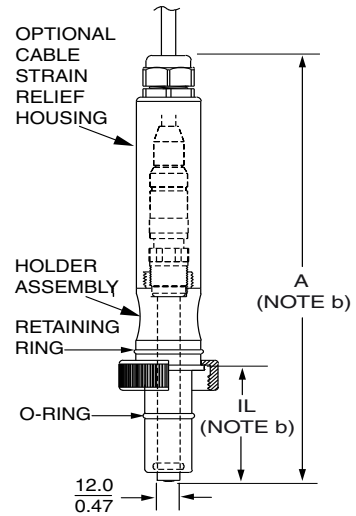

Dimension (a)	Electrode Type (b)	Immersion Length Code	Sensor Length			
			120 mm (4.7 in)	225 mm (8.9 in)	360mm (14.2 in)	425mm (16.7 in)
IL (b)	Domed Glass	040	40 (1.6)	-	-	-
		070	70 (2.8)	-	-	-
		100	-	100 (4.0)	-	-
		150	-	150 (5.9)	-	-
		175	-	175 (6.9)	-	-
		200	-	-	200 (7.9)	-
		275	-	-	275 (10.8)	-
A (b)	Domed	375	-	-	-	375 (14.8)
		All	259 (10.2)	364 (14.3)	499 (19.6)	564 (22.2)

a. IL - Maximum Immersion Length.

b. Dimensions IL and A are shown for the domed electrode configuration. For flat electrode (flat glass or platinum) dimensions, deduct 3.3 mm (0.13 in) from the dimensions in the table.

NOTE

1. For overall length without optional cable strain relief housing, refer to Model PH12 dimensions shown in the DIMENSIONS-NOMINAL section.
2. For dimensions of Optional Cable Strain Relief Housing (Option -1), refer to Dimensional Drawing of the housing in this document.
3. Refer to Dimensional Print, DP 611-214.

mm
in

MODEL PH12 SENSOR WITH MODELS FIT12-1/FIT12-2 MOUNTING ACCESSORIES

Model FIT12-1F***** - 1
Domed Glass/Guarded

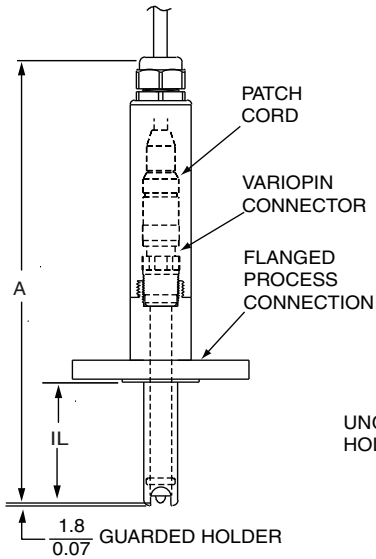

Model FIT12-2F***** - 1
Domed Glass/Unguarded

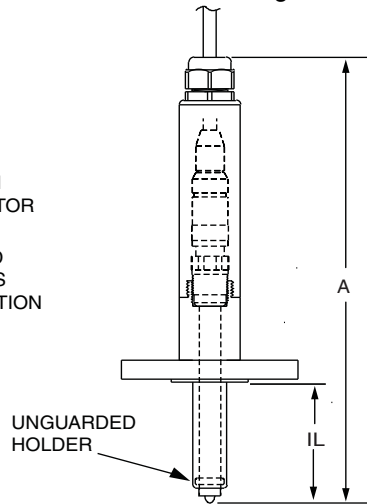

Model FIT12-2F***** - 1
Flat Electrode/Unguarded

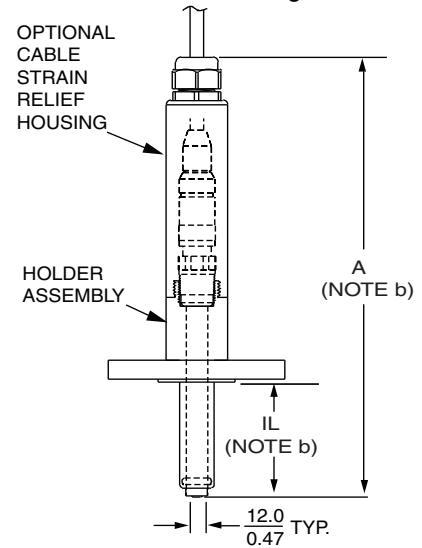

Dimension (a)	Electrode Type (b)	Immersion Length Code	Sensor Length			
			120 mm (4.7 in)	225 mm (8.9 in)	360mm (14.2 in)	425mm (16.7 in)
IL (b)	Domed Glass	025	25 (1.0)	-	-	-
		033	33 (1.3)	-	-	-
		040	40 (1.6)	-	-	-
		070	70 (2.8)	-	-	-
		100	-	100 (4.0)	-	-
		150	-	150 (5.9)	-	-
		175	-	175 (6.9)	-	-
		200	-	-	200 (7.9)	-
		275	-	-	275 (10.8)	-
A (b)	Domed	375	-	-	-	375 (14.8)
		ALL	259 (10.2)	364 (14.3)	499 (19.6)	564 (22.2)

- a. IL - Maximum Immersion Length.
- b. Dimensions IL and A are shown for the domed electrode configuration. For flat electrode (flat glass or platinum) dimensions, deduct 3.3 mm (0.13 in) from the dimensions in the table.

NOTE

1. For overall length without optional cable strain relief housing, refer to Model PH12 dimensions shown in the DIMENSIONS-NOMINAL section.
2. For dimensions of Optional Cable Strain Relief Housing (Option -1), refer to Dimensional Drawing of the housing in this document.
3. Refer to Dimensional Print, DP 611-214.

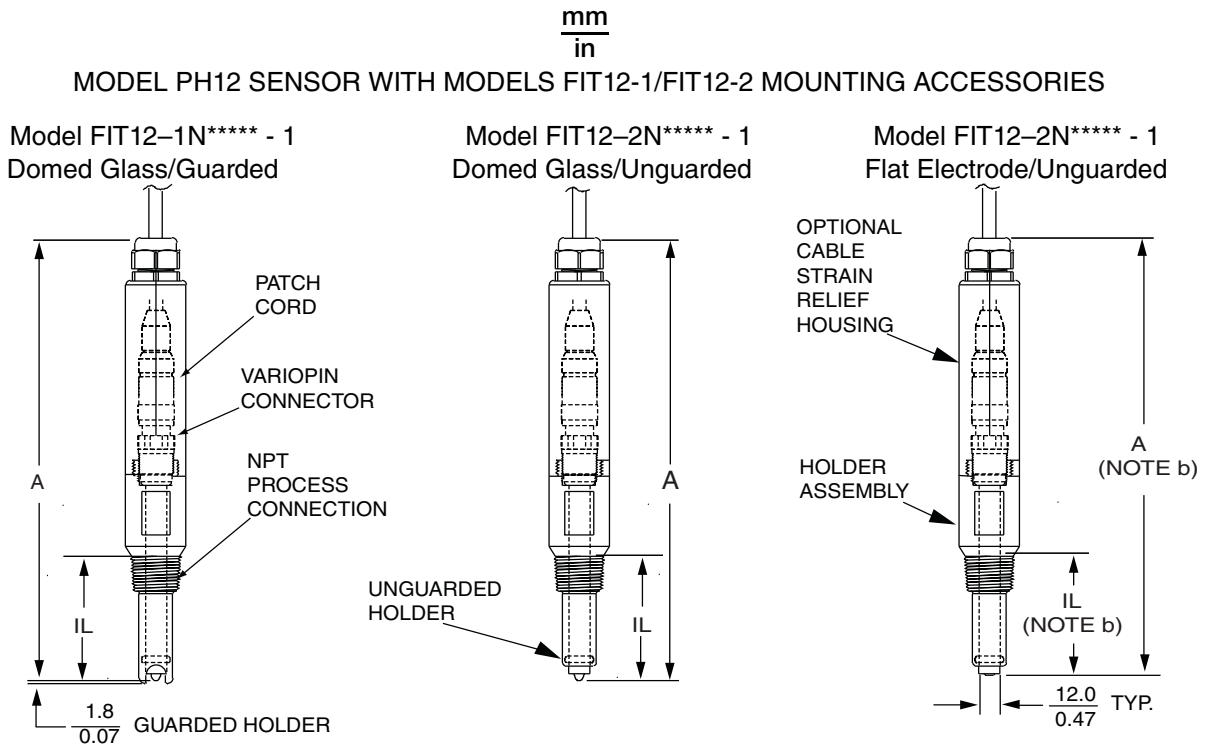

Dimension (a)	Electrode Type (b)	Immersion Length Code	Sensor Length			
			120 mm (4.7 in)	225 mm (8.9 in)	360 mm (14.2 in)	425 mm (16.7 in)
IL (b)	Domed Glass	025	25 (1.0)	-	-	-
		033	33 (1.3)	-	-	-
		040	40 (1.6)	-	-	-
		070	70 (2.8)	-	-	-
		100	-	100 (4.0)	-	-
		150	-	150 (5.9)	-	-
		175	-	175 (6.9)	-	-
		200	-	-	200 (7.9)	-
		275	-	-	275 (10.8)	-
A (b)	Domed	375	-	-	-	375 (14.8)
		ALL	259 (10.2)	364 (14.3)	499 (19.6)	564 (22.2)

- a. IL - Maximum Immersion Length
- b. Dimensions IL and A are shown for the domed electrode configuration. For flat electrode (flat glass or platinum) dimensions, deduct 3.3 mm (0.13 in) from the dimensions in the table.

NOTE

1. For overall length without optional cable strain relief housing, refer to Model PH12 dimensions shown in the DIMENSIONS-NOMINAL section.
2. For dimensions of Optional Cable Strain Relief Housing (Option -1), refer to Dimensional Drawing of housing in the document.
3. Refer to Dimensional Print, DP 611-214.

MODEL PH12 SENSORS WITH MODELS FIT12-1NA/FIT12-NB MOUNTING ACCESSORIES
USER-SUPPLIED TEE AND BUSHING INSTALLATION OPTIONS

FIT12-1NA033□
33 mm (1.3 in) IMMERSION

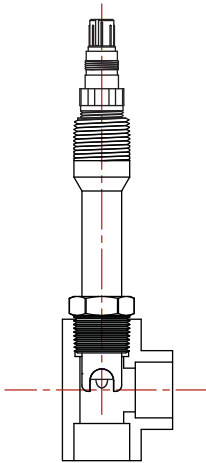

VERTICAL 3/4" NPT
TEE INSTALLATION

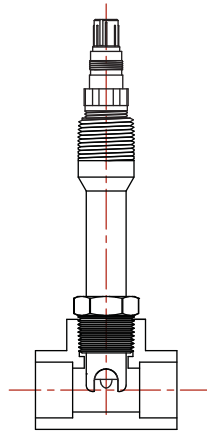

HORIZONTAL 3/4" NPT
TEE INSTALLATION

FIT12-1NA040□
40 mm (1.6 in) IMMERSION

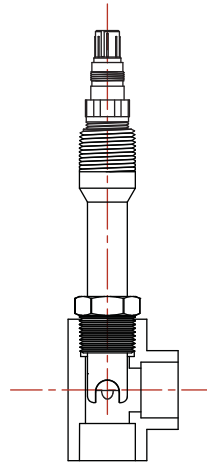

VERTICAL 3/4" NPT
TEE INSTALLATION

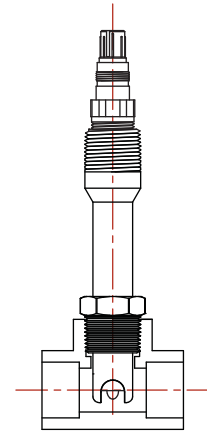

HORIZONTAL 3/4" NPT
TEE INSTALLATION

FIT12-1NB040□
40 mm (1.6 in) IMMERSION

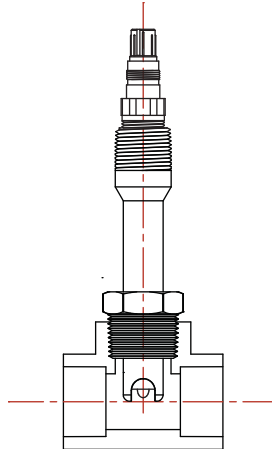

HORIZONTAL 1" NPT
TEE INSTALLATION*

FIT12-1NB070□
70 mm (2.8 in) IMMERSION

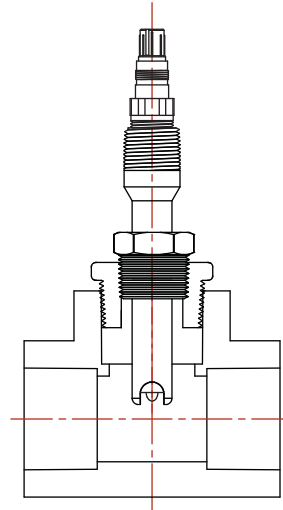

HORIZONTAL 1 1/2" NPT
TEE INSTALLATION* WITH
USER-SUPPLIED TEE AND
BUSHING

* VERTICAL INSTALLATION NOT SHOWN

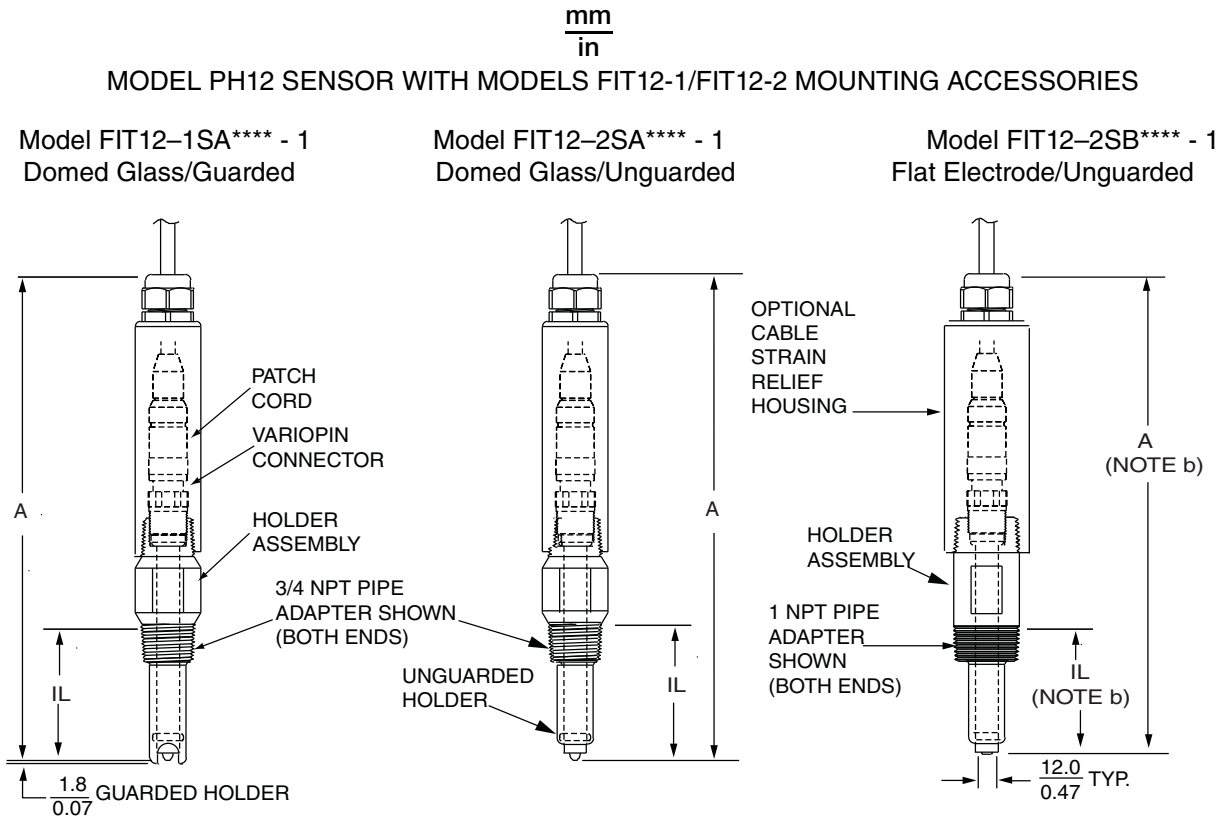

Dimension (a)	Electrode Type (b)	Immersion Length Code (c)	Pipe Adaptor Code	Sensor Length
				120 mm (4.7 in)
IL (b)	Domed Glass	040	SA, SB	40 (1.6)
		070	SA, SB	70 (2.8)
A (b)	Domed Glass	040	SA, SB	229 (9.0)
		070	SA, SB	259 (10.2)

- a. IL - Maximum Immersion Length.
- b. Dimensions IL and A are shown for the domed electrode configuration. For flat electrode (flat glass or platinum) dimensions, deduct 3.3 mm (0.13 in) from the dimensions in the table.
- c. Immersion Length Codes 000, 025, and 033 are not available with a holder assembly.

NOTE

- 1. For overall length without optional cable strain relief housing, refer to Model PH12 dimensions shown in the DIMENSIONS-NOMINAL section.
- 2. For dimensions of Optional Cable Strain Relief Housing (Option-1), refer to Dimensional Drawing of housing in this document.
- 3. Refer Dimensional Print, DP 611-214.

MODEL PH12 SENSORS WITH MODELS FIT12-1SA/FIT12-SB MOUNTING ACCESSORIES
USER-SUPPLIED TEE AND BUSHING INSTALLATION OPTIONS

FIT12-1SA040□
40 mm (1.6 in) IMMERSION

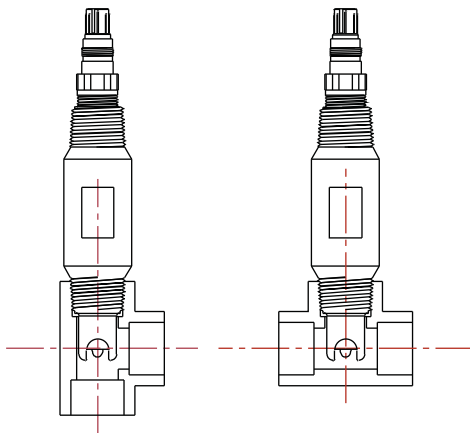

VERTICAL 3/4" NPT
TEE INSTALLATION

HORIZONTAL 3/4" NPT
TEE INSTALLATION

FIT12-1SB040□
40 mm (1.6 in) IMMERSION

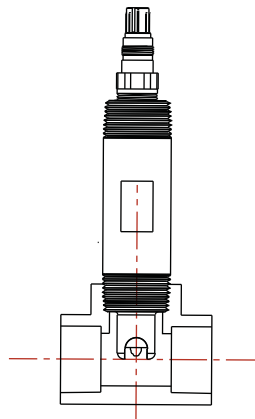

HORIZONTAL 1" NPT
TEE INSTALLATION*

FIT12-1SB070□
70 mm (2.8 in) IMMERSION

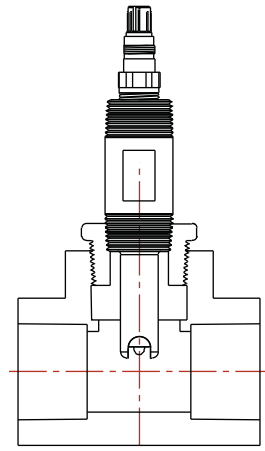

HORIZONTAL 1 1/2" NPT
TEE INSTALLATION* WITH
USER-SUPPLIED TEE AND
BUSHING

* VERTICAL INSTALLATION NOT SHOWN

mm
in

MODEL PH12 SENSOR WITH MODELS FIT12-1/FIT12-2 MOUNTING ACCESSORIES

Model FIT12-1TB***L - 1
Domed Glass/Guarded

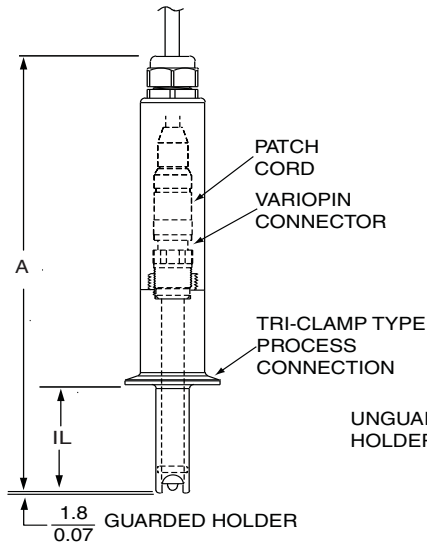

Model FIT12-2TC***L - 1
Domed Glass/Unguarded

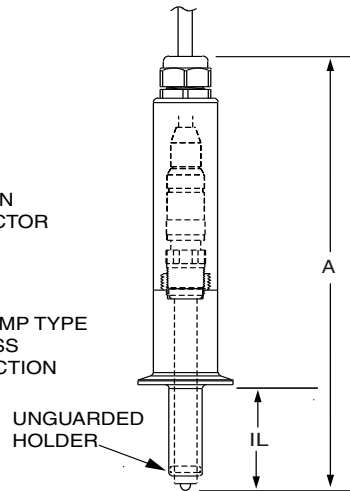

Model FIT12-2TD***L - 1
Flat Electrode/Unguarded

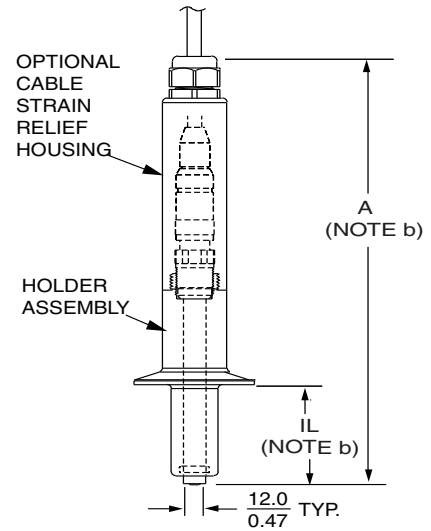

Dimension (a)	Electrode Type (b)	Immersion Length Code	Sensor Length			
			120 mm (4.7 in)	225 mm (8.9 in)	360mm (14.2 in)	425mm (16.7 in)
IL (b)	Domed Glass	040	40 (1.6)	-	-	-
		070	70 (2.8)	-	-	-
		100	-	100 (4.0)	-	-
		150	-	150 (5.9)	-	-
		175	-	175 (6.9)	-	-
		200	-	-	200 (7.9)	-
		275	-	-	275 (10.8)	-
		375	-	-	-	375 (14.8)
A (b)	Domed	All	259 (10.2)	364 (14.3)	499 (19.6)	564 (22.2)

a. IL - Maximum Immersion Length.

b. Dimensions IL and A are shown for the domed electrode configuration. For flat electrode (flat glass or platinum) dimensions, deduct 3.3 mm (0.13 in) from the dimensions in the table.

NOTE

1. For overall length without optional cable strain relief housing, refer to Model PH12 dimensions shown in the DIMENSIONS-NOMINAL section.
2. For dimensions of Optional Cable Strain Relief Housing (Option-1), refer to Dimensional Drawing of housing in this document.
3. Refer to Dimensional Print DP 611-214.

$\frac{\text{mm}}{\text{in}}$

OPTIONAL CABLE STRAIN RELIEF HOUSING

Model FIT-1***** - 1

and

Model FIT-2***** - 1

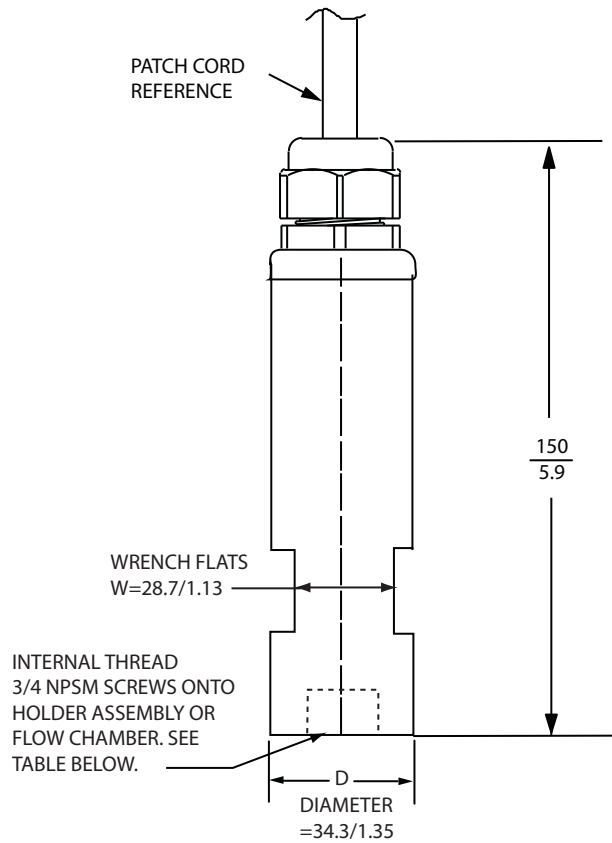

NOTE

Also refer to Dimensional Print DP 611-214.

$\frac{\text{mm}}{\text{in}}$

MODEL PH12 SENSOR WITH MODEL FIT12-1R*****
RETRACTION/INSERTION ACCESSORY

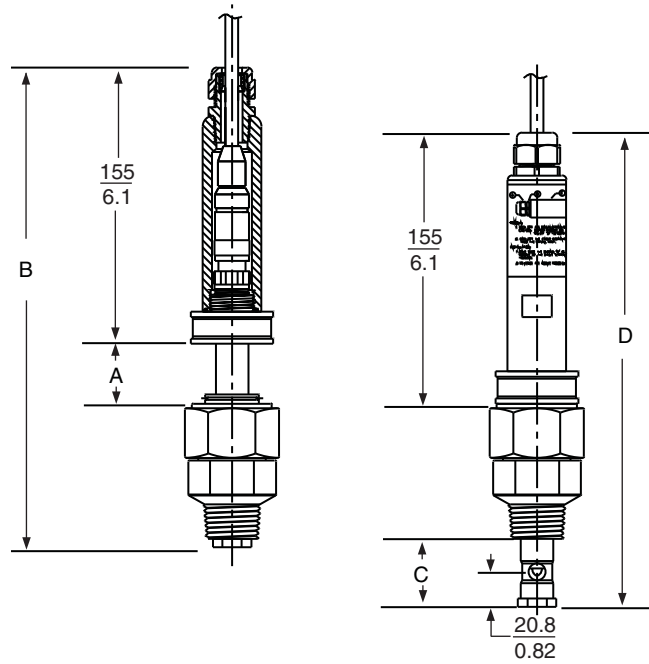

Dimension	Sensor Lengths			
	120 mm (4.7 in)	225 mm (8.4 in)	360 mm (14.2 in)	425 mm (16.7 in)
A	0 to 36 mm (0 to 1.4 in)	0 to 141 mm (0 to 5.6 in)	0 to 276 mm (0 to 10.9 in)	0 to 342 mm (0 to 13.5 in)
B	280 mm (11.0 in)	384 mm (15.1 in)	521 mm (20.5 in)	584 mm (23.0 in)
C	0 to 40 mm (0 to 1.6 in)	0 to 145 mm (0 to 5.7 in)	0 to 280 mm (0 to 11.1 in)	0 to 346 mm (0 to 13.6 in)
D	280 mm (11.0 in)	384 mm (15.1 in)	521 mm (20.5 in)	584 mm (23.0 in)

NOTE

Also refer to Dimensional Print DP 611-214.

BALL VALVE INSERTION ASSEMBLY

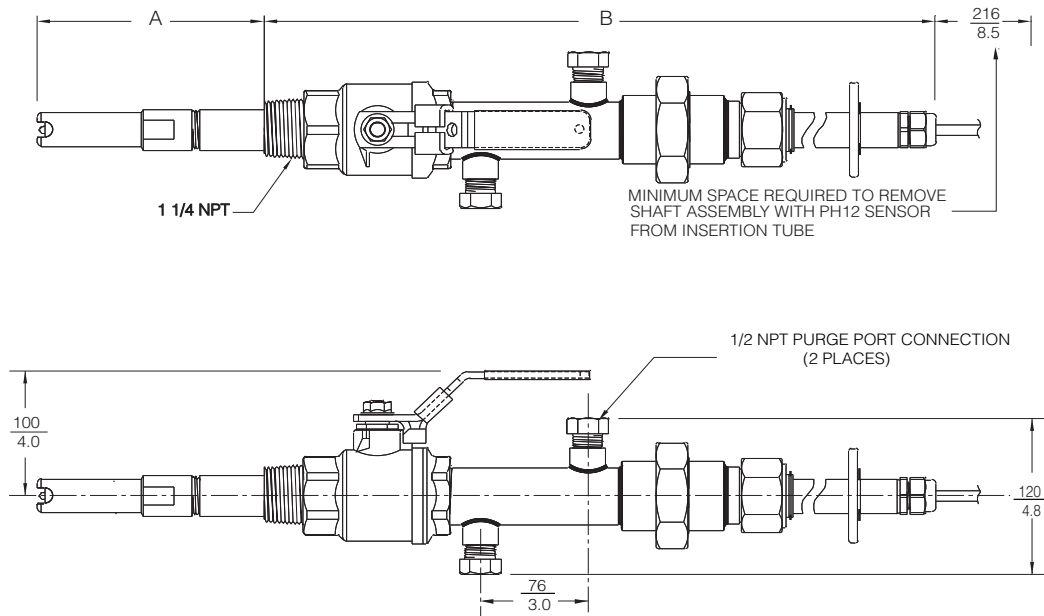

Ball Valve Material	Dimension "A" Insertion Length	Dimension "B" (a) Overall Length
316 ss	0 to 20 cm (0 to 8 in)	75 cm (29.5 in)
316 ss	0 to 40 cm (0 to 16 in)	95 cm (37.5 in)
316 ss	0 to 60 cm (0 to 24 in)	115 cm (45.5 in)
316 ss	0 to 80 cm (0 to 32 in)	135 cm (53.5 in)
316 ss	0 to xx cm (0 to length per Sales order) (b)	
Titanium	0 to 20 cm (0 to 8 in)	77 cm (30.5 in)
Titanium	0 to 40 cm (0 to 16 in)	98 cm (38.5 in)
Titanium	0 to 60 cm (0 to 24 in)	117 cm (46.5 in)
Titanium	0 to 80 cm (0 to 32 in)	132 cm (54.5 in)
Titanium	0 to xx cm (0 to length per Sales order) (b)	

- a. Overall length B dimension is at the fully retracted position (not shown).
- b. Contact Invensys, available in 20 cm (8 inch) increments.

NOTE

The ball valve assembly is for use with the 120 mm (4.7 in) PH12 Sensor only.

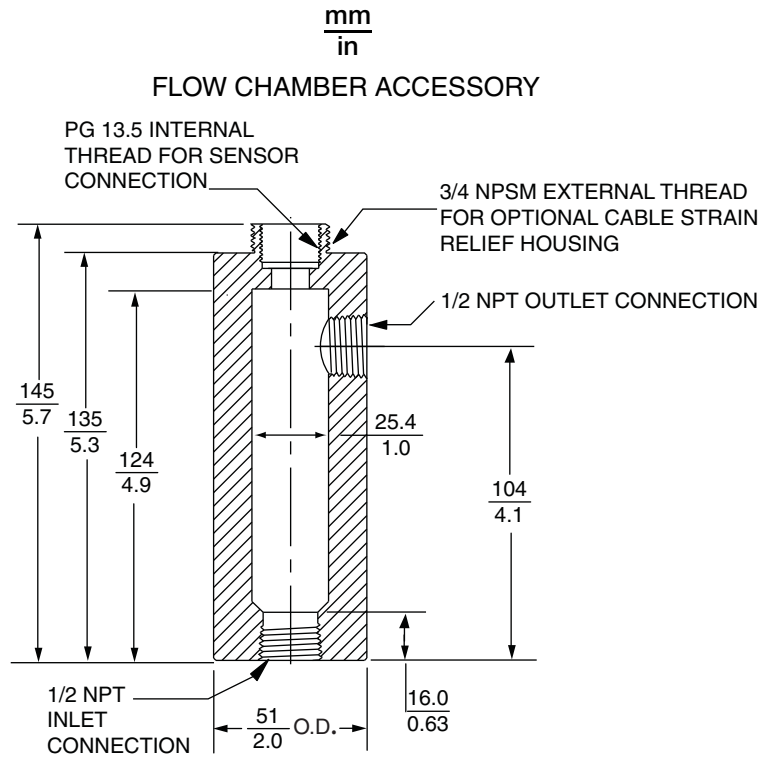

NOTE

The Flow Chamber accessory is for use with the 120 mm (4.7 in) PH12 Sensor only.

AUTOCLAVE CAP ACCESSORY

Model PH12-***** - A

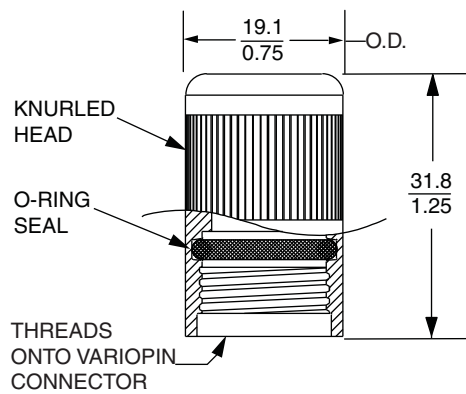

ORDERING INSTRUCTIONS

- 1 Sensor Model Number - PH12
- 2 Mounting Accessories Model Number - FIT12
- 3 Ball Valve Insertion Assembly Accessory Model Number - BV
- 4 Wiring Accessories Part Number(s).
- 5 Other Accessories:
- 6 User Tag Information.

OTHER FOXBORO PRODUCTS

The Foxboro product lines offer a broad range of measurement and instrument products, including solutions for pressure, flow, analytical, temperature, positioning, controlling, and recording.

For a list of these offerings, visit our web site at:

www.fielddevices.foxboro.com