

**871CC Contacting Conductivity and Resistivity Sensors and Accessories**

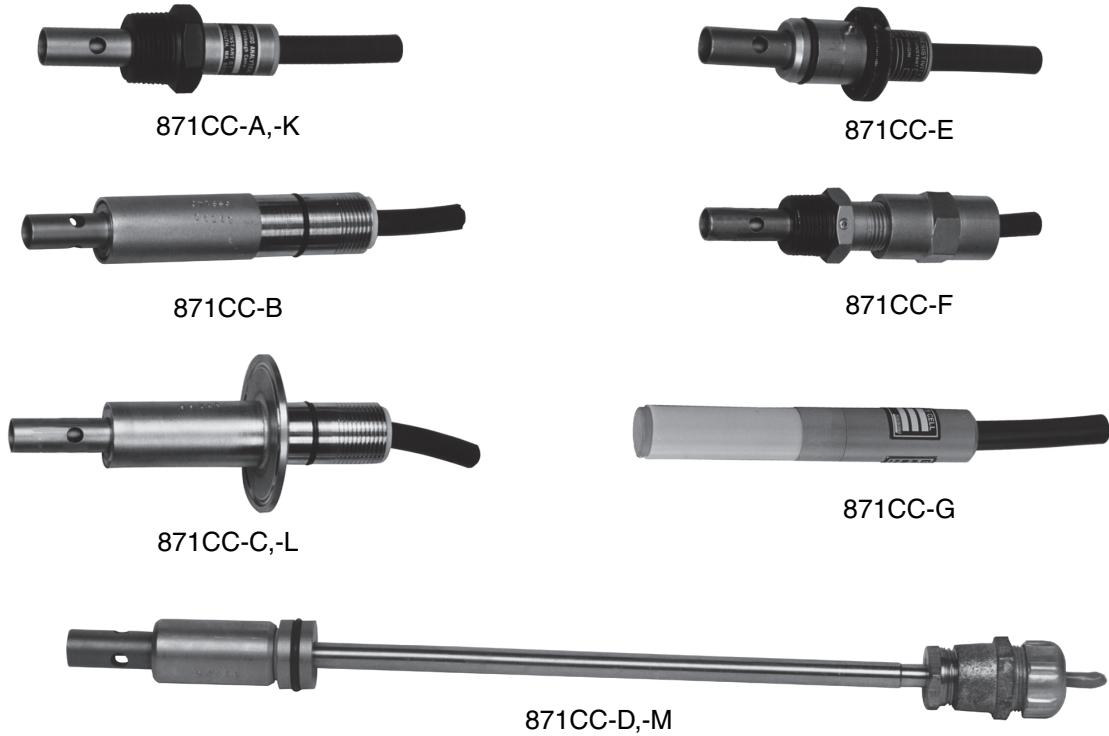

*Foxboro brand 871CC Sensors (Cells), in conjunction with supporting 871CC accessories, offer a dependable, fast, durable, and in-line means of measuring ionic content of a sample stream. As symbolized by the “CE” logo marking on the product, these sensors conform to the applicable European Union directives when used with the electrochemical analyzers and transmitters listed below.*

**INTRODUCTION**

871CC Contacting Conductivity/Resistivity Sensors are used with Foxboro 873CC, 873RS, 873ACC, 873ARS, 875CR, 870ITCR, and 876CR Electrochemical Analyzers and Transmitters to detect the conductivity or resistivity of a solution. The analyzer applies a low frequency voltage or current across the sensor electrodes in contact with the process fluid. The resulting electrical parameter is sampled, interpreted, temperature-corrected, and displayed by the analyzer.

**APPLICATION FLEXIBILITY**

A choice of two cell factors, 0.1 cm<sup>-1</sup> and 10 cm<sup>-1</sup>, is available for conductivity measurement. The required cell factor is dictated by the measurement type and range. Resistivity measurements always use a sensor having a cell factor of 0.1 cm<sup>-1</sup>. Conductivity measurements utilize both cell factors. 871CC Sensors are offered with a wide variety of mounting options and a choice of two temperature elements.

### QUALITY AND UNIFORMITY

871CC Sensors are manufactured under strict guidelines of quality and uniformity. In particular, sensors with  $0.1 \text{ cm}^{-1}$  cell factor (CF) have the actual CF stamped on the sensor and are within 2% of their nominal value.

The actual CF is determined using NIST traceable quality procedures. Optionally, resistivity cell factors can be determined in a Foxboro ultra-pure water loop (Option Code -9).

Simply enter the CF and temperature CF into the applicable factory-calibrated analyzer and you have a fully-calibrated measurement system!

### INTEGRAL TEMPERATURE SENSOR

All sensors use an integral temperature element whose signal is used by the analyzer for temperature compensation and measurement. Sensors are available with either a  $100 \text{ k}\Omega$  thermistor or  $100 \Omega$  RTD. For elevated temperatures, the  $100 \Omega$  RTD is recommended. Optimum positioning of these transducers within the sensor ensures close thermal contact with the process and, thus, rapid response to temperature change.

Temperature cell factors (tCF) are determined and stamped on each  $0.1 \text{ cm}^{-1}$  cell-factor sensor. This factor indicates the offset, in  $^{\circ}\text{C}$ , resulting from the resistance of the RTD or thermistor cable. Entering this value into the analyzer or transmitter accurately calibrates the RTD or thermistor to the instrument.

### TITANIUM, MONEL AND CARBON ELECTRODES

The  $0.1 \text{ cm}^{-1}$  CF sensor is constructed with titanium or Monel<sup>®</sup> electrodes. Titanium oxidizes naturally to form a chemically passive but electrically conducting surface. It is compatible with most fluids except acidic fluorides. For applications using acidic fluorides, Monel electrodes can be used. The electrodes have a concentric cylinder configuration.

The  $10 \text{ cm}^{-1}$  cell-factor sensor uses high density graphite electrodes.

### VARIETY OF ACCESSORIES

A large selection of accessories is offered to meet virtually all process requirements. This includes process-mounting accessories such as flow chambers, gate valve assemblies, and tees.

Figure 1. Measurement Range of Sensors

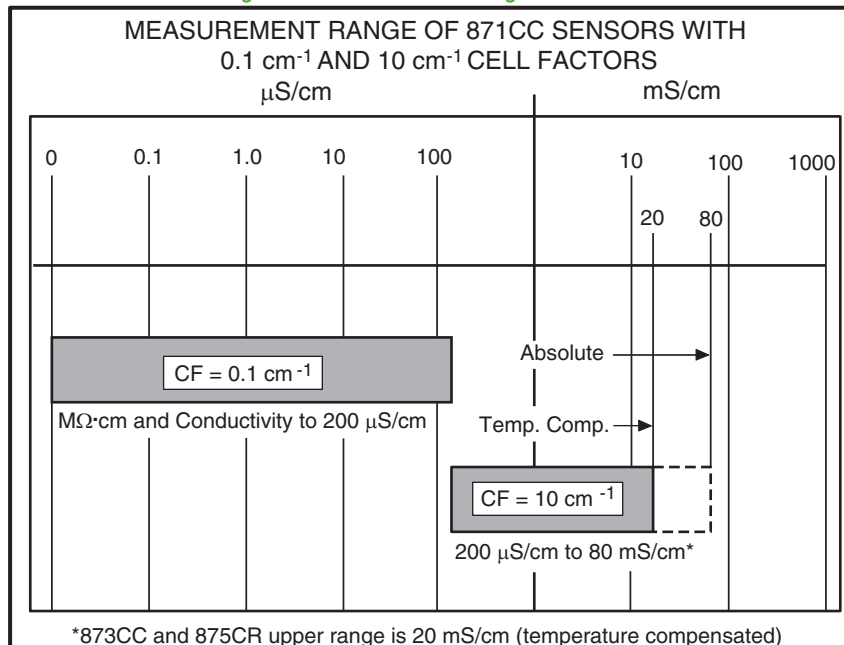
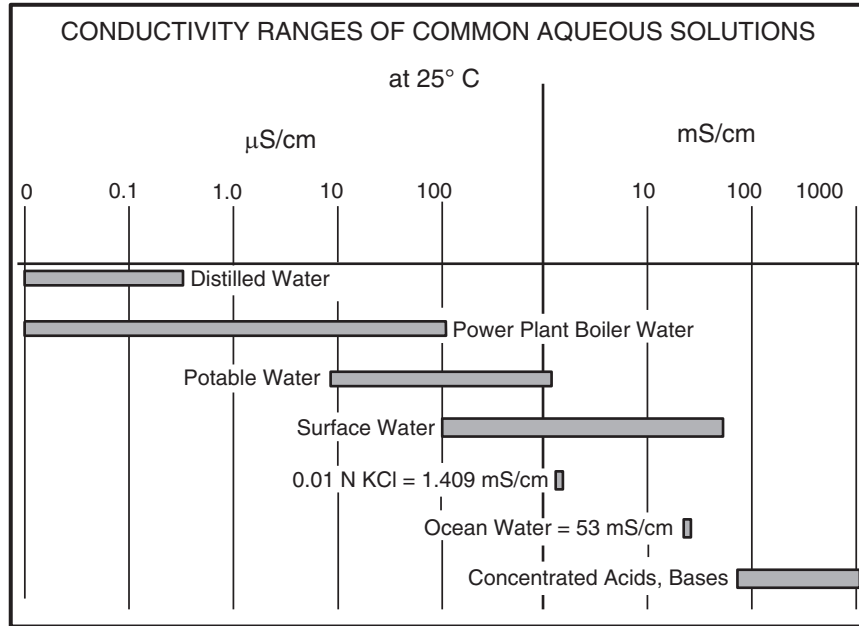

Figure 2. Conductivity Ranges of Common Aqueous Solutions



Conversion Table -  $\mu\text{S/cm}$  versus  $\text{Ohm}\cdot\text{cm}$  - at 25°C (77°F)









Conductance $\mu\text{S/cm}$	Resistance $\text{Ohm}\cdot\text{cm}$	Conductance $\mu\text{S/cm}$	Resistance $\text{Ohm}\cdot\text{cm}$	Conductance $\mu\text{S/cm}$	Resistance $\text{Ohm}\cdot\text{cm}$
0.055	18,300,000	2	500,000	26	38,461
0.063	16,000,000	4	250,000	30	33,333
0.071	14,000,000	6	166,667	40	25,000
0.083	12,000,000	8	125,000	50	20,000
0.100	10,000,000	10	100,000	60	16,667
0.125	8,000,000	12	83,333	80	12,500
0.167	6,000,000	14	71,428	100	10,000
0.25	4,000,000	16	62,500	120	8,333
0.5	2,000,000	18	55,555	160	6,250
1	1,000,000	22	45,454	200	5,000

MODEL CODE



Description	Model
Contacting Conductivity or Resistivity Sensor (a)	871CC
<b>Sensor Mounting and Transducer</b>	
Threaded Bushing, 3/4 NPT	Thermistor, 100 kΩ -A
Universal	Thermistor, 100 kΩ -B
Sanitary	Thermistor, 100 kΩ -C
Insertion	Thermistor, 100 kΩ -D
Twist-Lock	Thermistor, 100 kΩ -E
Threaded Bushing, 3/4 NPT with 1/2 NPT Conduit Connector	Thermistor, 100 kΩ -F
Dip Sensor	Thermistor, 100 kΩ -G
Threaded Bushing, 3/4 NPT, High Temperature (b)	RTD, 100 Ω -K
Sanitary, High Temperature (b)	RTD, 100 Ω -L
Insertion, High Temperature (b)	RTD, 100 Ω -M
<b>Cell Factor and Electrode Material</b>	
0.1 cm <sup>-1</sup> , Titanium	2
10 cm <sup>-1</sup> , Graphite	4
0.1 cm <sup>-1</sup> , Monel (Mounting Codes -A, -G, and -K only)	6
<b>Optional Selections (c)</b>	
Nonstandard Cable Length (Specify length) (d)	-3
No Spade Lug Terminals Attached to End of Cable	-4
Nonstandard Length Integral Cable Terminated in Connector.	-5
Specify Length. For Mounting Codes -A and -G only. (d) (e)	
Integral Connector on Sensor. For Mounting Code -A only. (e) (f)	-6
Standard Length 6 m (20 ft) Integral Cable Terminated in Connector.	-7
For Mounting Codes -A and -G only. (e) (f)	
Cell Factor Determined in Foxboro Pure Water Loop	-9
Examples: 871CC-B2; 871CC-A4-34 (40 ft); 871CC-A2-349 (20 m)	

- a. When an 871CC Series sensor is used with 873RS, 873ARS, 873CC, or 873ACC Series analyzer, Option Code -4 must be specified.
- b. The -K, -L, and -M sensors contain an integral 100 Ω RTD for automatic temperature compensation. This RTD is compatible with 873RS, 873ARS, 873CC, 873ACC, and 875CR Series Analyzers, and 870ITCR and 876CR Transmitters. No temperature compensation can be applied when used with 870CC Series Transmitters.
- c. Except for Option Codes -3, -4, and -9 which may be combined (e.g., -34, -349, etc.), only one Option Code may be specified.
- d. Maximum cable length:
  - for 870CC, 870ITCR, and 876CR Transmitters and 875CR Analyzer, 33 m (100 ft);
  - for 873RS, 873ARS, 873CC, and 873ACC Analyzers, 152 m (500 ft).
- e. Requires use of Patch Cord; part numbers as follows:
  - BS805UA, for 3 m (10 ft) length
  - BS805UB, for other lengths per Sales Order up to 33 m (100 ft).
- f. Not recommended for resistivity measurement.

SENSOR APPLICATIONS

Body Code	Applications	Sensor
-A	Standard sensors incorporating a 3/4 NPT Teflon®-S coated bushing. Offers a wide variety of installation configurations. Mating cell holders are also available.	
-B	Universal-mount sensors designed to utilize Foxboro flanges and hex-head bushings. Used in larger diameter piping and in the sides of tanks.	
-C	Sensors with sanitary fittings mate with 50 mm (2 in) Tri-Clamp® sanitary fitting.  A 40 mm (1 1/2 in) Tri-Clamp fitting is also available. Contact Global Customer Support about option EP125A.	
-D	Insertion sensors are used with gate-valve insertion systems that allow the sensor to be inserted or removed from the system without shutting down the system.	
-E	Twist-lock sensors are used with mating cell holders. A quarter turn by hand permits removal of the sensor for inspection and cleaning, or for an occasional grab sample.	
-F	Threaded bushings, 3/4 NPT with 1/2 NPT conduit connector.	
-G	Dip sensors are used manually in exposed liquids for occasional checks. Has Noryl® body.	
-K	High temperature bushing is 3/4 NPT with Teflon-S coating. 100 Ω RTD. Cable rated to 150°C (300°F). Same application as for -A above.	

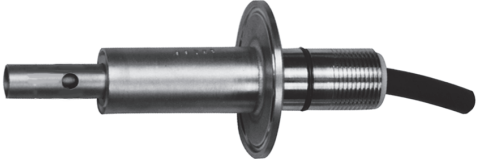
SENSOR APPLICATIONS

Body Code	Applications	Sensor
-L	<p>High temperature with sanitary fitting that mates with 50 mm (2 in) Tri-Clamp sanitary fitting. 100 Ω RTD. Cable rated to 150°C (300°F). Same application as for -C above.</p> <p>A 40 mm (1 1/2 in) Tri-Clamp fitting is also available. Contact Global Customer Support about option EP125A.</p>	
-M	<p>High temperature insertion type with 100 Ω RTD. Cable rated to 150°C (300°F). Same application as for -D above.</p>	

STANDARD SPECIFICATIONS

**Wetted Parts Materials**

See Table 1.

**Temperature and Pressure Limits**

See Table 2.

**Transportation and Storage Temperature Limits**

-48 and +125°C (-55 and +255°F).

**Conductivity Ranges**

For both 0.1 cm<sup>-1</sup> and 10 cm<sup>-1</sup> cell-factor sensors. See Table 2.

**Resistivity Ranges**

For 0.1 cm<sup>-1</sup> cell factor sensor only. See Table 2.

**Temperature Compensation (Integral)**

See Table 2.

**Cable**

Sensor Models 871CC-A to 871CC-G have integral PVC-insulated cable rated to 105°C (220°F); Sensor Models 871CC-K to 871CC-M have integral Tefzel<sup>®</sup> insulated cable rated to 150°C (300°F). Cables are 6 m (20 ft) long, screened (shielded), terminated in numbered spade lugs, or lugless. Type of cable used and method of attaching the cable to the sensor are matched to the application and mounting of sensor.

**Mounting**

See “SENSOR APPLICATIONS” table for mounting specifications.

Table 1. Process Wetted Parts

Cell Factor	Body Code	Seals/ O-Rings	Insulator (a)	Removable Sheath (b)	Fittings	Electrodes
Sensors with 3/4 NPT Bushing or Twist-Lock Process Connection						
0.1 cm <sup>-1</sup>	-A	EPDM	Ryton®	None	Teflon-S coated 300 grade ss bushing	Titanium or Monel, as specified by Model Code
	-F	EPDM	Ryton	None		
	-K	EPDM	PCTFE	None		
	-E	EPDM	Ryton	None	Twist Lock	
10 cm <sup>-1</sup>	-A	EPDM	Noryl	PTFE	Teflon-S coated 300 grade ss bushing	High density graphite encapsulated in gold-plated cups
	-F	EPDM	Noryl	PTFE		
	-K	EPDM	PCTFE	PTFE		
	-E	EPDM	Noryl	PTFE	Twist Lock	
Universal-Mount, Insertion, and Dip Sensors						
0.1 cm <sup>-1</sup>	-B	EPDM	Ryton	None	316 ss	Titanium or Monel, as specified by Model Code
	-G	EPDM	Ryton	None	Noryl	
	-D	EPDM	Ryton	None	316 ss (includes insertion shaft)	
	-M	EPDM	PCTFE	None		
10 cm <sup>-1</sup>	-B	EPDM	Noryl	PTFE	316 ss	High density graphite encapsulated in gold-plated cups
	-G	EPDM	Noryl	PTFE	Noryl	
	-D	EPDM	Noryl	PTFE	316 ss (includes insertion shaft)	
	-M	EPDM	PCTFE	PTFE		
Sensors with Sanitary (Tri-Clamp) Fittings						
0.1 cm <sup>-1</sup>	-C	EPDM	Ryton	None	316 ss	Titanium or Monel, as specified by Model Code
	-L	EPDM	PCTFE	None	316 ss	
10 cm <sup>-1</sup>	-C	EPDM	Noryl	PTFE	316 ss	High density graphite encapsulated in gold-plated cups
	-L	EPDM	PCTFE	PTFE	316 ss	

a. Ryton is polyphenylene sulfide; PCTFE is polychlorotrifluoroethylene.

b. PTFE is polytetrafluoroethylene.

Table 2. Pressure and Temperature Limits, Conductivity and Resistivity Ranges, and Temperature Compensation

Body Code	Temperature Limits (a) (b)	Pressure Limits	Applicable Conductivity and Resistivity Ranges (c)		Temperature Compensator (Integral)
			Cell Factor 0.1 cm <sup>-1</sup> (d)	Cell Factor 10 cm <sup>-1</sup>	
-A to -G	0 and 120°C (32 and 250°F)	-0.1 and +1.4 MPa (-15 and +200 psi)	From 0 to 1 through 0 to 200 μS/cm Conductivity Range	0 to 200 μS/cm through 0 to 20 mS/cm Conductivity Range	100 kΩ thermistor for use with 873RS, 873ARS, 873CC, 873ACC, and 875CR analyzers; 870CC, 870ITCR, and 876CR transmitters.
-K to -M	120°C at 3.4 MPa (250°F at 500 psi); 150°C at 2.5 MPa (300°F at 375 psi); 175°C at 1.7 MPa (350°F at 250 psi) (e)		From 0 to 2 through 0 to 20 MΩ•cm Resistivity Range (f)		100 Ω platinum RTD for use with 873RS, 873ARS, 873CC, 873ACC, and 875CR analyzers; 870ITCR and 876CR transmitters. (g)

- Temperature limits for optimum performance and compensation: 871CC-A through 871CC-G = 15 and 40°C (60 and 105°F); 871CC-K through 871CC-M = 15 and 80°C (60 and 175°F).
- Recalibration is recommended for 10 cm<sup>-1</sup> cell-factor sensors after exposure to elevated temperatures. Refer to the "Calibration" chapter in the MI.
- Ranges shown are typical. For specific range capability, refer to the applicable analyzer or transmitter specifications.
- All 0.1 cm<sup>-1</sup> cell-factor sensors with Body Codes A through M are labeled with the exact cell factor and temperature cell factor. All 0.1 cm<sup>-1</sup> cell-factor sensors are constructed and tested for an accuracy of better than ±2%.
- Specifications are for 0.1 cm<sup>-1</sup> cell-factor sensors only. Maximum temperature for 10 cm<sup>-1</sup> cell-factor sensor is 150°C at 2.5 MPa (300°F at 375 psi).
- Specify Option Code -9.
- If -K, -L, or -M sensor is to be used with 870CC Series Transmitters, no automatic temperature compensation can be applied. RTDs are not supported in these instruments.



## ELECTRICAL SAFETY SPECIFICATIONS

These sensors have been designed to meet the electrical safety descriptions listed in Table 3. For detailed information, or status of testing laboratory approvals/certifications, contact Global Customer Support.

Table 3. Electrical Safety Specifications

Testing Laboratory, Types of Protection, and Area Classification	Application Conditions	Electrical Safety Design Code
<b>ATEX</b> Type n energy limited for II 3 GD EEx nL IIC, Zone 2.	Connect to instrument per MI 611-208. Temperature Class T3 - T6. T110°C - T260°C.	CS-E/ANN
<b>ATEX</b> intrinsically safe for II 1 GD EEx ia IIC, Zone 0.	Connect to instrument per MI 611-208. Temperature Class T3 - T6. T110°C - T260°C.	CS-E/AAA
<b>CSA</b> intrinsically safe for Class I, Division 1, Groups A, B, C, and D; Class II, Division 1, Groups E, F, and G.	Connect to 870CC transmitter per MI 611-206.	CS-E/CB-A
<b>CSA</b> Class I, Division 2, Groups A, B, C, and D hazardous locations.	Connect to 873CC or 873ACC Analyzer with Supply Voltage Code -A, -E, or -J, and Enclosure Code W, X, Y, or Z. Connect per MI 611-206.	CS-E/CN-A
<b>CSA</b> suitable for Class I, Division 2, Groups A, B, C, and D; Class II, Division 2, Groups E, F, and G; Class III, Division 2.	Connect to 875CR Analyzer per MI 611-206. Supply Voltage -A, -B, -C, -E, or -J. Temperature Class T4 at 85°C (185°F) maximum ambient.	875CR-**C
<b>CSA</b> certified for Class I, II, and III, Division 2, Groups A, B, C, D, F, and G.	Connect to 870ITCR Transmitter per MI 611-206. Temperature Class T4.	870ITCR-**CNZ
<b>CSA</b> certified intrinsically safe for Class I, II, and III, Division 1, Groups A, B, C, D, F; and G Division 2.	Connect to 870ITCR Transmitter per MI 611-206. Temperature Class T4.	870ITCR-**CAA
<b>FM</b> intrinsically safe Class I, II, and III, Division 1, Groups A, B, C, D, E, F, and G.	Connect to 870 transmitters per MI 611-206. 871CC-**-6 Sensors are excluded.	CS-E/FB-A
<b>FM</b> ordinary locations.	Connect to 873CC or 873ACC Analyzers with Enclosure Code P, W, X, Y, or Z.	CS-E/FG-A
<b>FM</b> nonincendive Class I, Division 2, Groups A, B, C, and D; Class II, Division 2, Groups F and G; Class III, Division 2.	Connect to 875CR Analyzer per MI 611-206. Supply Voltage -A, -B, -C, and -J. Temperature Class T4A at 75°C maximum ambient.	875CR-**F
<b>FM</b> ordinary location.	Connect to 875CR Analyzer. Supply Voltage -A, -B, -C, and -J. Temperature Class T4A at 75°C maximum ambient.	875CR-**F
<b>FM</b> approved nonincendive for Class I, II, and III, Division 1, Groups A, B, C, D, F, and G; and Division 2.	Temperature Class T4. Connect to 870ITCR Transmitter per MI 611-206.	870ITCR-**FNZ
<b>FM</b> approved intrinsically safe for Class I, II, and III, Division 1, Groups A, B, C, D, E, F, and G.	Temperature Class T4. Connect to 870ITCR Transmitter per MI 611-206.	870ITCR-**FAA

ACCESSORIES

Accessory	Description	Part Number
Gate Valve Assembly (Used with Sensor Body Code -D or -M)	Standard Pressure-Temperature Rating High Pressure-Temperature Rating	0051351 0051356
Flange, AISI Type 316 stainless steel	2 in DN 50 (50 mm) 2 1/2 in 3 in 4 in DN 100 (100 mm)	0051199 BS805JL 0051196 0051197 0051198 BS805JM
Bushing, 316 ss (a)	1 1/4 NPT 1 1/4 NPT 1 1/2 NPT 1 1/2 NPT R 1 1/2 Metric 2 NPT R 2 Metric	0051174 0051191 0051175 0051192 BS805JJ 0051193 BS805JC
Bushing, Carpenter 20Cb-3®	1 1/4 NPT 1 1/2 NPT R 1 1/2 Metric 2 NPT R 2 Metric	0051176 0051177 BS805JK 0051178 BS805JD
Bushing, Kynar®	1 1/2 NPT R 1 1/2 Metric 2 NPT R 2 Metric	BS805JF BS805JH BS805HZ BS805JB
Bushing, Noryl	1 1/2 NPT R 1 1/2 Metric 2 NPT R 2 Metric	BS805JE BS805JG BS805HY BS805JA
Bushing, PVC (a)	1 1/4 NPT	0051183
Flow Chamber (b)	Twist-Lock (PVC) Twist-Lock (316 ss) 3/4 NPT Threaded (PVC) 3/4 NPT Threaded (316 ss) 3/4 NPT Threaded (Sygef®)	0051181 0051179 0051182 0051180 BS805GR
Junction Box	Meets IEC IP65 and NEMA 4 specifications, watertight fittings	0051052
Extension Cable Assembly	<u>With</u> spade terminals. Specify length up to 152 m (500 ft) (c)	0061101
Extension Cable	<u>Without</u> spade terminals. Specify length up to 152 m (500 ft) (c)	6000-062
Patch Cord	<u>Standard Length</u> : 3 m (10 ft) <u>Nonstandard Length</u> : Specify length up to 33 m (100 ft) (c)	BS805UA BS805UB

- a. See Table 8 for rated pressure at rated temperature selections.
- b. See Table 6 for rated pressure at rated temperature selections.
- c. See Table 9 for maximum allowable total cable/patch-cord length between sensor and measuring instrument.

**Gate Valve Assembly**

A gate valve assembly enables the user to easily install and withdraw the insertion sensor (Sensor Body Code -D or -M) while the process is pressurized. The small diameter insertion shaft gives a 1:10 ratio of insertion force to process pressure - that is, at a process pressure of 1.4 MPa (200 psi), only 89 N (20 lbf) is required to insert the sensor. The damping effect of process liquid, trapped behind sensor, adds a safety factor by slowing the passage of the sensor into the isolation chamber. See Table 4 and Table 5 for additional specifications and part numbers.

Table 4. Gate Valve Assemblies (a)

Process Line Connection (in)	Pressure Rating	0051351 Illustrated
1 NPT	Standard Rating (0051351) High-Pressure Rating (0051356)	

a. For use with 871CC-D or 871CC-M Sensor. Sensor is not included with the Valve Assembly.

Table 5. Gate Valve Assembly Specifications

Process Line Connection (in)	Rated Pressure at Rated Temperature				Material of Process Wetted Parts			Used with Sensor Body Code	Part No.
	MPa	psi	°C	°F	Gate Valve	Shock Absorber	O-Ring (a)		
1 NPT	1.4	200	120	250	316 ss	PTFE	EPDM	-D, -M	0051351
	3.4	500	120	250	316 ss	PTFE	EPDM	-M	0051356

a. The o-ring is located on the sensor assembly and is not part of the gate valve assembly.

**Flow Chambers**

Flow chambers offer a convenient way of mounting sensors in a system where the sample is provided by a small diameter sample line. The flow chamber connects to the system via user supplied 1/4 NPT

and provides a chamber for the sample. A flow chamber with a sensor in place will pass up to 125 mL/s (2 gpm) of sample. See Table 6 for additional specifications and part numbers.

Table 6. Flow Chamber Specifications

Sensor Connector and Mounting Design Code	Material	Rated Pressure at Rated Temperature				Part No.	0051179 Illustrated
		MPa	psi	°C	°F		
Twist-Lock (-E)	PVC	0.4 0.2	60 30	50 80	120 175	0051181	
Twist-Lock (-E)	316 ss	1.4	200	125	260	0051179	
3/4 NPT Threaded (-A)	PVC	0.4 0.2	60 30	50 80	120 175	0051182	
3/4 NPT Threaded (-A, -K)	316 ss	14	2000	175	350	0051180	
3/4 NPT Threaded (-A)	Sygef	0.4 0.2	60 30	50 80	120 175	BS805GR	

### Flanges and Bushings

Foxboro raised-face flanges and hex-head bushings are used for permanent installations in pipelines and tanks. Flanges are used with universal mount sensors (Sensor Body Code -B) in systems using process piping larger than 3/4 in, while hex-head bushings can be used with either universal or Twist-

Lock mounting design. Flanges come complete with spacers and locknut, while the bushings come complete with locknut. See Table 7 (flanges) and Table 8 (bushings) for additional specifications and part numbers.

Table 7. Flange Specifications – Flat Faced (FF) or Raised Face (RF), as Indicated

Size (a)	Material	Part No.	0051198 Illustrated
2 in, FF	316 ss	0051199	
DN 50, RF	316 ss	BS805JL	
2 1/2 in, FF	316 ss	0051196	
3 in, FF	316 ss	0051197	
4 in, FF	316 ss	0051198	
DN 100, RF	316 ss	BS805JM	

a. Pressure and temperature rating: DIN 2501, 10 bar, for DN 50 and DN 100 sizes. MS Class I50LW for 2, 2 1/2, 3, and 4 in sizes. Used with sensor having Universal Mounting Design (Code -B).

Table 8. Hex-Head Bushing Specifications

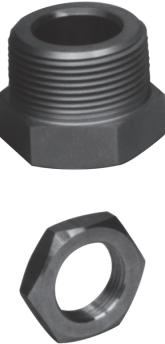
Used with Sensor Body Code	Material	Rated Pressure at Rated Temperature				Thread Size (in)	Part No.	0051191 Illustrated		
		MPa	psi	°C	°F					
Twist-Lock (-E)	PVC	0.4	60	50	120	1 1/4 NPT	0051183			
		0.2	30	80	175					
Universal (-B)	316 ss	1.4	200	125	260	1 1/4 NPT 1 1/2 NPT	0051174 0051175			
		Carpenter 20Cb-3	1.4	200	125	260	1 1/4 NPT 1 1/2 NPT R 1 1/2 2 NPT R 2		0051191 0051192 BS805JJ 0051193 BS805JC	
			Kynar	1.0	150	25	77		1 1/2 NPT R 1 1/2 2 NPT R 2	0051176 0051177 BS805JK 0051178 BS805JD
				0.4	60	80	175			
	0.2			30	120	250				
	0.2	30		120	250					
	Noryl	1.4	200	25	77	1 1/2 NPT R 1 1/2 2 NPT R 2	BS805JF BS805JH BS805HZ BS805JB			
		0.7	100	80	175					
0.3		50	95	200						
0.3		50	95	200						

**Junction Box**

*(Not recommended for resistivity measurement)*

The junction box (Figure 3) mounts to a surface and provides a convenient means of connecting the sensor cable to the extension cable (see “Extension Cable Assembly” section). The junction box is weatherproof and dusttight as defined by IEC IP65 and provides the watertight protection of NEMA Type 4. Specify part number 0051052.

Figure 3. Junction Box and Terminal Connectors (Part # 0051052)

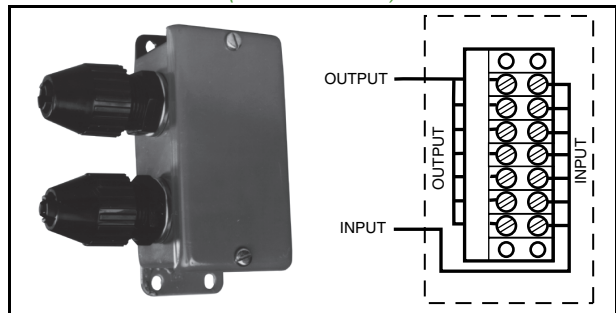

### Extension Cable Assembly

*(Not recommended for resistivity measurement)*  
The extension cable assembly (Figure 4) is a PVC-jacketed multi-conductor cable with numbered leads, and is terminated with spade lugs on both ends allowing it to be connected to the terminals in a junction box (Figure 3) and in the measuring instrument. See Table 9 for cable application, part number, and maximum allowable total cable/patch-cord length between the sensor and the instrument.

Figure 4. Extension Cable Assembly (Part # 0061101)  
Shielded per Figure 5

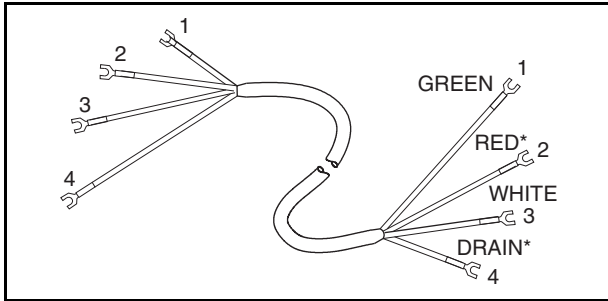

### Extension Cable

*(Not recommended for resistivity measurement)*  
The extension cable (Figure 5) is a PVC-jacketed multi-conductor cable. The cable is not dressed and has no terminations. See Table 9 for cable application, part number, and maximum allowable total cable/patch-cord length between the sensor and the measuring instrument.

Figure 5. Extension Cable  
(Part # 6000-062)

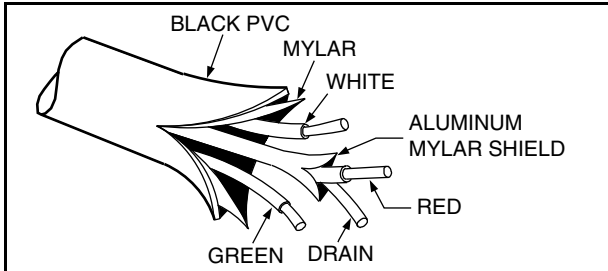

### Patch Cord

*(Not recommended for resistivity measurement)*  
Patch cords (not shown) provide connections between sensors with optional suffixes -5, -6, -7, and a transmitter, analyzer, switch, or junction box. One end of the patch cord has a socket for connection to the sensor; the other end has numbered leads. See Table 9 for patch cord application, part number, and maximum allowable total cable/patch-cord length between the sensor and the measuring instrument.

Table 9. Extension Cable and Patch Cord Usage

Model	Accepts Spade Lugs?	Max Length (a)	Cable Part No.	Patch Cord Part No.
870ITCR 876CR 875CR	YES	33 m (100 ft)	0061101	<b>3 m (10 ft):</b> BS805UA
873CC 873ACC	NO	152 m (500 ft)	6000-062	<b>Up to 33 m (100 ft):</b> BS805UB

a. Maximum allowable total cable/patch cord length between the sensor and the measuring instrument.

DIMENSIONS-NOMINAL

SENSOR MOUNTING

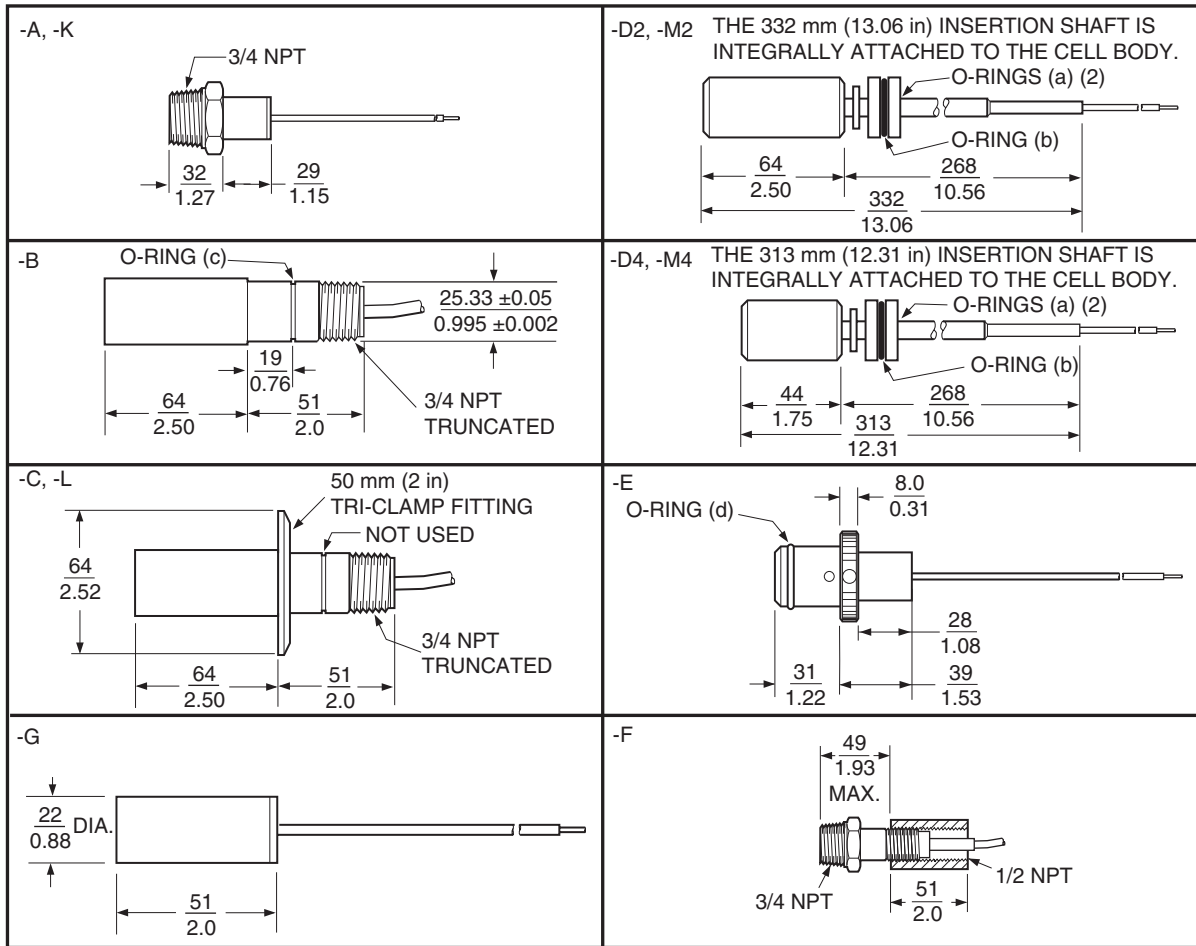

NOTE: O-RINGS PER AEROSPACE STANDARD AS-568A AS FOLLOWS:  
(a) No. 2-012 (b) No. 2-117 (c) No. 2-020 (d) No. 2-116

CELL MOUNTING

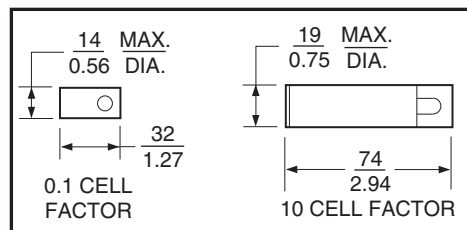

NOTE:

For total sensor length, add cell factor length (shown at left) to the left of the sensor mounting length (above).

For available cable lengths, refer to the Model Code and Accessories sections.

mm  
in

## ORDERING INSTRUCTIONS

1. Model Number
2. Cable length, if nonstandard
3. Accessories, as required. Specify part number and cable length.
4. Customer tag data
5. Contact Name (for order inquiries)

## OTHER FOXBORO PRODUCTS

The Foxboro product lines offer a broad range of measurement and instrument products, including solutions for pressure, flow, analytical, temperature, positioning, controlling, and recording. For a list of these offerings, visit our web site at:

[www.fielddevices.foxboro.com](http://www.fielddevices.foxboro.com)