

**Enterprise Control System Series Component Transmitters IDP15D,
IDP31D, and IDP32D Differential Pressure Transmitters**



The Foxboro® brand Enterprise Control System Series Component Differential Pressure Transmitters IDP15D, IDP31D, and IDP32D are microprocessor-based smart transmitters that provide precise, reliable, measurement of differential pressure, and features high performance and excellent stability. Capable of measuring gas, liquid, vapor, and liquid levels, it transmits 4 to 20mA dc analog and digital signals according to the measured differential pressure. It can also execute two-way communications using HART protocol, thus facilitating self-diagnosis, range resetting, and automatic zero adjustment.

HIGH DEPENDABILITY

- ▶ Unique characterization and composite semiconductor sensors realize high accuracy up to 0.04% F.S.
- ▶ Proven Sensor technology enables Long-term stability up to 0.1% of URL per 10-year period.
- ▶ A wide measuring range is available from a single model. This feature is highly effective in taking measurement over a wide range and reducing the need for inventory.
- ▶ Model IDP31D and IDP32D: 0.5 to 100kPa (rangeability: 200 to 1).
- ▶ Two-way communication using HART protocol facilitates self-diagnosis, range resetting, automatic zero adjustment, and other operations.
- ▶ HART communication protocol.
- ▶ Complies with 89/336/EEC, 92/31/EEC, and 93/68/EEC Electromagnetic Compatibility (EMC) Directive.
- ▶ Complies with FM Explosionproof and Dust Approvals, FM Intrinsically Safe Approval, and FM Nonincendive Approval.
- ▶ Complies with ATEX Flameproof and Dust, ATEX Intrinsic safety and Dust, and ATEX Type n and Dust Certifications.

OIL FREE FINISH

The transmitter is shipped with oil-free wetted parts.

ADAPTERS FOR ANTICORROSION MATERIALS

These are adaptor flanges to connect 82 mm pipes made of anticorrosion materials [excluding ASTM B575 (Equivalent to Hastelloy C-276)] to 54 mm general-purpose pipes.

EXTERNAL ZERO/SPAN ADJUSTMENT FUNCTION

The transmitter can be easily zero/span adjusted in the field.

CONFORMANCE TO NON SI UNITS

We deliver transmitters set to any Non SI units as specified.

SAFETY TRANSMITTER

Select this option to be used as a component of Safety Instrument System (SIS).

ECS Series Component Transmitters comply with IEC61508, certified according to Safety Integrity Level2 (SIL-2) when this option is selected.

ALARM OUTPUT (CONTACT OUTPUT)

Contact output is prepared as alarm output when alarm (Output Alarm/Sensor Temp. Alarm) condition is detected. It can be set to Normally Open. (When alarm is detected, Contact ON).

PHYSICAL SPECIFICATIONS

Material	Description
Fill Fluid	Silicone oil for general purpose models Fluorine oil for oxygen and chlorine models
Transmitter Housing	Aluminum alloy
Meter Body Cover Flange	SCS14A (Equivalent to 316 SST)
For Wetted Parts	
Adaptor Flange Option	SCS14A (Equivalent to 316 SST)
Center Body	316 SST (Diaphragm 316L SST) or ASTM B575 (Equivalent to Hastelloy C) ^(a)
Vents and Plugs	316 SST
Weight	Approximately 3.7 kg (Model IDP31D)

(a) For IDP31D only

INSTALLATION

Material	Description
Electrical connection	1/2NPT internal thread, M20 internal thread
Grounding	Resistance 100 Ω max
Mounting	Can be installed on a 2-inch horizontal or vertical pipe (can be directly mounted on a process pipe)
Process connection	1/4NPT internal thread

NOTE

Impact to transmitter can damage sensor module.

FUNCTIONAL SPECIFICATIONS

EMC CONFORMITY

89/336/EEC, 92/31/EEC, 93/68/EEC Electromagnetic Compatibility (EMC) Directive.

Any ECS Series Component Pressure Transmitter model having a maximum working pressure that is higher than the pressure corresponding to its group does not conform to SEP and cannot be used.

PED CONFORMITY (97/23EC)

The maximum pressures applicable under the Sound Engineering Practice (SEP) section of the Pressure Equipment Directive depend on the type of fluids measured, as shown in Table 1. Devices in the ECS Series Component Differential Pressure Transmitters shall be used at or below the applicable pressure in the table or the device's maximum working pressure, whichever is lower.

To know more about maximum pressures that are applicable for gases and liquids, see Table 1.

Table 1. Maximum Pressures Applicable

Measurement Fluid	Group ^(a)	Pressure	Applicable Models
Gas	1	200 bar (20 MPa)	All models except IDP32D
	2	1000 bar (100 MPa)	All models
Liquid	1	500 bar (50 MPa)	All models
	2	1000 bar (100 MPa)	All models

(a) Group 1 comprises fluids defined as: explosive, extremely flammable, highly flammable, flammable, very toxic, toxic and oxidizing.
Group 2 comprises all other fluids not included in Group 1.

FUNCTIONAL SPECIFICATIONS (CONT.)

MEASURING SPAN / SETTING RANGE /
WORKING PRESSURE RANGE

Table 2. Span Limits for ECS Series Component Pressure Transmitters

Model Code	kPa	Psi	bar	mmHg	mmH ₂ O	inH ₂ O
IDP15D	0.1 and 2	0.015 and 0.29	0.001 and 0.2	0.75 and 15	10.20 and 203.94	0.4 and 8
IDP31D	0.5 and 100	0.07 and 14.5	0.005 and 1	3.75 and 750	50 and 10,160	2 and 400
IDP32D	0.5 and 100	0.07 and 14.5	0.005 and 1	3.75 and 750	50 and 10,160	2 and 400

Table 3. Range Limits for ECS Series Component Pressure Transmitters

Model Code	kPa	Psi	bar	mmHg	mmH ₂ O	inH ₂ O
IDP15D	-1 and +1	-0.145 and +0.145	-0.01 and +0.01	-7.5 and +7.5	-102 and +102	-4 and +4
IDP31D	-100 and +100	-14.5 and +14.5	-1 and +1	-750 and +750	-10,160 and +10,160	-400 and +400
IDP32D	-100 and +100	-14.5 and +14.5	-1 and +1	-750 and +750	-10,160 and +10,160	-400 and +400

Table 4. Working Pressure Limits for ECS Series Component Pressure Transmitters

Model Code	kPa	Psi	bar	mmHg	mmH ₂ O	inH ₂ O
IDP15D	-70 and +210	-10 and +30	0.7 and +2.1	-525 and +1575	-7130 and +21,400	-280 and +840
IDP31D ^{(a),(b)}	2 (abs) and 21,000	0.29 (abs) and 3045	0.02 (abs) and 210	15 (abs) and 157,500	204 (abs) and 2,140,000	8 (abs) and 84,300
IDP32D ^(c)	2 (abs) and 42,000	0.29 (abs) and 6090	0.02 (abs) and 420	15 (abs) and 315,000	204 (abs) and 4,280,000	8 (abs) and 168,600

(a) In case these models are installed in countries requiring CE Marking, maximum working pressure is limited to 20 MPa (200 kgf/cm²).

(b) With 304 SST bolts and nuts, the maximum working pressure is 10 MPa (100 kgf/cm²) (IDP31D only).

(c) With 304 SST bolts and nuts, the maximum working pressure is 23.3 MPa (233 kgf/cm²) (IDP32D only).

FUNCTIONAL SPECIFICATIONS (CONT.)

SUPPLY VOLTAGE AND LOAD RESISTANCE

17.9 to 42 V dc. A load resistance of 250 Ω or more is necessary between loops. See Figure 1.

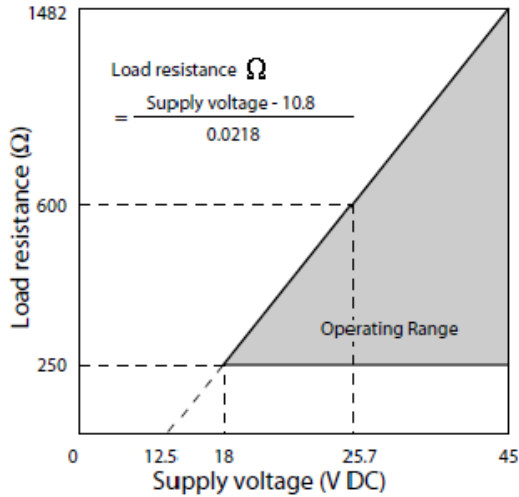

Figure 1. Supply Voltage versus Load Resistance

NOTE

For communication with HART communicator, a load resistance of 250 Ω or more is necessary.

OUTPUT

Analog output (4 to 20 mA dc) with HART protocol

OUTPUT SIGNAL

3.6 to 21.6 mA

3.8 to 20.5 mA (NAMUR NE43 compliant)

FAILURE ALARM

Upper: 21.6 mA or more

Lower: 3.6 mA or less

BOLTS AND NUTS MATERIALS (FOR FASTENING METER BODY COVER)

304 SST, 630 SST (IDP31D and IDP32D)

AMBIENT TEMPERATURE LIMITS

To know more about normal operating range, operating limits, and transportation and storage conditions, see Table 5.

To know more about temperature ranges for wetted parts, see Table 5.

AMBIENT HUMIDITY LIMITS

5 to 100% RH

STABILITY AGAINST SUPPLY VOLTAGE CHANGE

± 0.005% FS/V

RESPONSE TIME

Below 100 msec (for model IDP31D, when damping time is set to 0 sec).

Below 300 msec (for models IDP15D and IDP32D).

DAMPING TIME

0 to 128 sec

ZERO STABILITY

± 0.1% of URL per 10-year (for models IDP31D/32D)

± 1.0% of URL per 10-year (for model IDP15D)

LIGHTNING PROTECTION

Applicable Standards; IEC 61000-4-5

Peak value of current surge (80/20 μsecond): 6000A

INDICATOR

The digital LCD indicator (optional) indicates engineering units and can be set freely between -9999 and 9999. For meter calibration, specify the following items:

- ▶ Meter calibration range
- ▶ Meter calibration unit
- ▶ Linear / Square-root for meter indication

Various kinds of data can be set using the HART® communicator.

FUNCTIONAL SPECIFICATIONS (CONT.)

Table 5. Temperature and Electrical Limits

Models	Influence	Reference Operating Conditions	Normal Operating Conditions	Operative Limits	Storage and Transportation Limits
IDP15D	Process Connection Temperature With Silicone Fill	23 ± 2°C (73 ± 3°F)	-15 to 65°C (+5 to 150°F)	-40 and 70°C (-40 and 158°F)	N/A
	With Fluorine Fill	23 ± 2°C (73 ± 3°F)	-10 to 65°C (+14 to 150°F)	-40 and 70°C (-40 and 158°F)	N/A
	Electronics Temperature Without LCD Indicator	23 ± 2°C (73 ± 3°F)	-15 to 65°C (+5 to 150°F)	-40 and 70°C (-40 and 158°F)	-15 and 65°C (+5 and 150°F)
	With LCD Indicator	23 ± 2°C (73 ± 3°F)	-15 to 65°C (+5 to 150°F)	-40 and 70°C (-40 and 158°F)	-15 and 65°C (+5 and 150°F)
	Relative Humidity ^(a)	50 ± 10%	5 to 100%	5 and 100%	5 and 100% Noncondensing
	Supply Voltage-mA Output	3 ± 0.5 V dc	17.9 to 42 V dc	17.9 and 42 V dc	N/A
Output Load-mA Output	650 Ω	0 to 1482 Ω	0 and 1482 Ω	N/A	
IDP31D	Process Connection Temperature With Silicone Fill	23 ± 2°C (73 ± 3°F)	-40 to 110°C (-40 to 230°F)	-50 and 115°C (-58 and 239°F)	N/A
	With Fluorine Fill	23 ± 2°C (73 ± 3°F)	-20 to 75°C (-4 to 167°F)	-40 and 80°C (-40 and 176°F)	N/A
	Electronics Temperature Without LCD Indicator	23 ± 2°C (73 ± 3°F)	-40 to 85°C ^(b) (-40 to 180°F)	-50 and 93°C ^(c) (-58 and 200°F)	-50 and 85°C (-58 and 180°F)
	With LCD Indicator	23 ± 2°C (73 ± 3°F)	-25 to 80°C ^(b) (-13 to 176°F)	-30 and 85°C ^(c) (-22 and 180°F)	-50 and 85°C (-58 and 180°F)
	Relative Humidity ^(a)	50 ± 10%	5 to 100%	5 and 100%	5 and 100% Noncondensing
	Supply Voltage-mA Output	3 ± 0.5 V dc	17.9 to 42 V dc	17.9 and 42 V dc	N/A
Output Load-mA Output	650 Ω	0 to 1482 Ω	0 and 1482 Ω	N/A	

Table 5. Temperature and Electrical Limits (Continued)

Models	Influence	Reference Operating Conditions	Normal Operating Conditions	Operative Limits	Storage and Transportation Limits
IDP32D	Process Connection Temperature With Silicone Fill	23 ± 2°C (73 ± 3°F)	-15 to 110°C (+5 to 230°F)	-20 and 115°C (-4 and 239°F)	N/A
	With Fluorine Fill	23 ± 2°C (73 ± 3°F)	-15 to 75°C (+5 to 167°F)	-20 and 80°C (-4 and 176°F)	N/A
	Electronics Temperature Without LCD Indicator	23 ± 2°C (73 ± 3°F)	-15 to 85°C ^(d) (+5 to 180°F)	-25 and 93°C ^(c) (-13 and 200°F)	-15 to 85°C (+5 to 180°F)
	With LCD Indicator	23 ± 2°C (73 ± 3°F)	-15 to 80°C ^(d) (+5 to 176°F)	-25 and 85°C ^(c) (-13 and 180°F)	-15 to 85°C (+5 to 180°F)
	Relative Humidity ^(a)	50 ± 10%	5 to 100%	5 and 100%	5 and 100% Noncondensing
Supply Voltage-mA Output	24 ± 0.5 V dc	17.9 to 42 V dc	17.9 and 42 V dc	N/A	
Output Load-mA Output	650 Ω	0 to 1482 Ω	0 and 1482 Ω	N/A	

(a) With topworks cover on and conduit entrances sealed

(b) -10 to 75°C (+14 to 167°F) for Fluorine fill fluid

(c) -40 to 80°C (-40 to 176°F) for Fluorine fill fluid

(d) -15 to 65°C (+5 to 149°F) for Fluorine fill fluid

PERFORMANCE SPECIFICATIONS

Shown for each item are the percentage ratio for χ (kPa), which is the greatest value of either the upper range value (URV)⁽¹⁾, the lower range value (LRV)⁽²⁾, or the span.

Table 6. Reference Accuracy – Model IDP15D, Model IDP31D, and IDP32D

Model	Attributes	Description
Model IDP15D	Reference Accuracy ^(a)	Linear Output: $\pm \left(0.15 + 0.15 \times \frac{1.0}{\chi} \right) \%$
		Square-Root Output: When output is 50 to 100%: same as the linear output. When output is 7.1 to 50%: linear output $\times \frac{50}{\text{square-root of the output}} \%$ When output is less than 7.1%: dropout
	Ambient Temperature Effect (Shift from the calibrated range) Change of 30°C, from -5 to 55°C	Combined Shift (Including zero and % span shifts): $\pm \left(0.19 + 0.56 \times \frac{1.0}{\chi} \right) \%$
	Static Pressure Effect (Shift with respect to calibrated range) Change of 70 kPa (0.7 kgf/cm ²)	Zero Shift: $\pm \left(0.03 + 0.4 \times \frac{1}{\chi} \right) \%$ Combined Shift (Including zero and % span shifts): $\pm \left(0.03 + 0.45 \times \frac{1}{\chi} \right) \%$

(1) URV denotes the process value for 100% (20 mA dc) output

(2) LRV denotes the process value for 0% (4 mA dc) output

Table 6. Reference Accuracy – Model IDP15D, Model IDP31D, and IDP32D (Continued)

Model	Attributes	Description
Model IDP31D (for regular type)	Reference Accuracy ^{(a),(b)}	Linear Output: $\pm 0.04\%$ (For $\chi \geq 10.0$ kPa {1000 mmH2O}) $\pm \left(0.008 + 0.032 \times \frac{10}{\chi} \right) \%$ (For $\chi < 10$ kPa {1000 mmH2O}) <hr/> Square-Root Output: When output is 50 to 100%: same as the linear output. When output is 7.1 to 50%: linear output $\times \frac{50}{\text{square-root of the output}} \%$ When output is less than 7.1%: dropout
	Ambient Temperature Effect (Shift from the calibrated range) ^(b) Change of 30°C, from -5 to 55°C	Combined Shift (Including zero and % span shifts): $\pm 0.15\%$ (For $\chi \geq 12.5$ kPa {1250 mmH2O}) $\pm \left(0.075 + 0.075 \times \frac{12.5}{\chi} \right) \%$ (For $\chi \leq 12.5$ kPa {1250 mmH2O})
	Static Pressure Effect (Shift with respect to calibrated range) ^(b) Change of 7 MPa (70 kgf/cm ²)	Zero Shift: $\pm \left(0.03 + 0.17 \times \frac{12.5}{\chi} \right) \%$
		Combined Shift (Including zero and % span shifts): $\pm \left(0.03 + 0.37 \times \frac{12.5}{\chi} \right) \%$

Table 6. Reference Accuracy – Model IDP15D, Model IDP31D, and IDP32D (Continued)

Model	Attributes	Description
Model IDP31D (for oxygen/chlorine service)	Reference Accuracy ^{(a), (b)}	Linear Output: $\pm 0.75\%$ (For $\chi \geq 50.0$ kPa {5000 mmH2O}) $\pm 0.1\%$ (For 50.0 kPa {5000 mmH2O} > $\chi \geq 5.0$ kPa {500 mmH2O}) $\pm \left(0.025 + 0.075 \times \frac{5.0}{\chi} \right) \%$ (For $\chi < 5.0$ kPa {500 mmH2O})
		Square-Root Output: When output is 50 to 100%: same as the linear output. When output is 7.1 to 50%: linear output $\times \frac{50}{\text{square-root of the output}} \%$ When output is less than 7.1%: dropout
	Ambient Temperature Effect (Shift from the calibrated range) ^(a) Change of 30°C, from -5 to 55°C	Combined Shift (Including zero and % span shifts): $\pm 0.44\%$ (For $\chi \geq 12.5$ kPa {1250 mmH2O}) $\pm \left(0.19 + 0.25 \times \frac{12.5}{\chi} \right) \%$ (For $\chi \leq 12.5$ kPa {1250 mmH2O})
Static Pressure Effect (Shift with respect to calibrated range) ^(a) Change of 7 MPa (70 kgf/cm ²)	Zero Shift: $\pm \left(0.03 + 0.17 \times \frac{20}{\chi} \right) \%$	
	Combined Shift (Including zero and % span shifts): $\pm 0.4\%$ (For $\chi \geq 20.0$ kPa {2000 mmH2O}) $\pm \left(0.03 + 0.37 \times \frac{20}{\chi} \right) \%$ (For $\chi < 20.0$ kPa {2000 mmH2O})	

Table 6. Reference Accuracy – Model IDP15D, Model IDP31D, and IDP32D (Continued)

Model	Attributes	Description
Model IDP31D (for ASTM B575)	Reference Accuracy ^{(a), (b)}	Linear Output: $\pm 0.2\%$ (For $\chi \geq 10$ kPa {1000 mmH2O}) $\pm \left(0.125 + 0.075 \times \frac{10}{\chi} \right) \%$ (For $\chi \geq 10$ kPa {1000 mmH2O})
		Square-Root Output: When output is 50 to 100%: same as the linear output. When output is 7.1 to 50%: linear output $\times \frac{50}{\text{square-root of the output}} \%$ When output is less than 7.1%: dropout
	Ambient Temperature Effect (Shift from the calibrated range) ^(a) Change of 30°C, from -5 to 55°C	Combined Shift (Including zero and % span shifts): $\pm \left(0.55 + 0.65 \times \frac{20.0}{\chi} \right) \%$
	Static Pressure Effect (Shift with respect to calibrated range) ^(a) Change of 7 MPa (70 kgf/cm ²)	Zero Shift: $\pm \left(0.03 + 0.62 \times \frac{20.0}{\chi} \right) \%$ Combined Shift (Including zero and % span shifts): $\pm \left(0.55 + 0.45 \times \frac{20.0}{\chi} \right) \%$ (For $\chi \geq 20.0$ kPa {2000 mmH2O}) $\pm \left(0.18 + 0.82 \times \frac{20.0}{\chi} \right) \%$ (For $\chi < 20.0$ kPa {2000 mmH2O})

Table 6. Reference Accuracy – Model IDP15D, Model IDP31D, and IDP32D (Continued)

Model	Attributes	Description
Model IDP32D	Reference Accuracy ^(a)	Linear Output: $\pm 0.075\%$ (For $\chi \geq 50.0$ kPa {5000 mmH2O}) $\pm 0.1\%$ (For 50.0 kPa {5000 mmH2O} $> \chi \geq 5.0$ kPa {500 mmH2O}) $\pm \left(0.025 + 0.075 \times \frac{5.0}{\chi} \right) \%$ (For $\chi < 5.0$ kPa {5000 mmH2O})
		Square-Root Output: When output is 50 to 100%: same as linear output. When output is 7.1 to 50%: linear output $\times \frac{50}{\text{square-root of the output}} \%$ When output is less than 7.1%: dropout
	Ambient Temperature Effect (Shift from the calibrated range) ^(b) Change of 30°C, from -5 to 55°C	Combined Shift (Including zero and % span shifts): $\pm 0.41\%$ (For $\chi \geq 12.5$ kPa {1250 mmH2O}) $\pm \left(0.18 + 0.23 \times \frac{12.5}{\chi} \right) \%$ (For $\chi \leq 12.5$ kPa {1250 mmH2O})
	Static Pressure Effect (Shift with respect to calibrated range) ^(b) Change of 7 MPa (70 kgf/cm ²)	Zero Shift: $\pm \left(0.03 + 0.17 \times \frac{20}{\chi} \right) \%$ Combined Shift (Including zero and % span shifts): $\pm 0.4\%$ (For $\chi \geq 20.0$ kPa {2000 mmH2O}) $\pm \left(0.03 + 0.37 \times \frac{20}{\chi} \right) \%$ (For $\chi < 20.0$ kPa {2000 mmH2O})

(a) Reference accuracy at calibrated condition, 25°C

(b) Within a range of URV ≥ 0 and LRV is ≥ 0 .

ELECTRICAL SAFETY SPECIFICATIONS

Testing Laboratory, Types of Protection, and Area Classification	Application Conditions	Electrical Safety Design Code
ATEX flameproof and dust certifications; II 1/2 G Ex d IIC T6...T4	Temperature Class T6, $T_a = -30^{\circ}\text{C}$ to $+75^{\circ}\text{C}$ T5, $T_a = -30^{\circ}\text{C}$ to $+80^{\circ}\text{C}$ T4, $T_a = -30^{\circ}\text{C}$ to $+80^{\circ}\text{C}$	A1
II 2 D Ex tD A21 IP6X T85 / T100 / T110°C	Maximum Surface Temperature T85°C, $T_a = -30^{\circ}\text{C}$ to $+75^{\circ}\text{C}$ T100°C, $T_a = -30^{\circ}\text{C}$ to $+75^{\circ}\text{C}$ T110°C, $T_a = -30^{\circ}\text{C}$ to $+75^{\circ}\text{C}$	
ATEX intrinsically safety and dust certifications; II 1 G, Ex ia IIC II 1 D Ex iaD 20 IP66/67 T105°C II 2 D Ex tD 21 IP66/67 T85°C...T110°C	Temperature Class T4, $T_a = -30^{\circ}\text{C}$ to $+60^{\circ}\text{C}$ Maximum Surface Temperature T105°C, $T_a = -30^{\circ}\text{C}$ to $+60^{\circ}\text{C}$ T85°C, $T_a = -30^{\circ}\text{C}$ to $+75^{\circ}\text{C}$ T100°C, $T_a = -30^{\circ}\text{C}$ to $+80^{\circ}\text{C}$ T110°C, $T_a = -30^{\circ}\text{C}$ to $+80^{\circ}\text{C}$	A2
ATEX protection type n; II 3 G Ex nL IIC	Temperature Class T4, $T_a = -30^{\circ}\text{C}$ to $+60^{\circ}\text{C}$	A5
FM explosionproof dust approvals; Class I, Division 1, Groups A, B, C, and D; Class I, Zone 1, AEx d IIC and Dust-ignition proof for Class II and III, Division 1, Groups E, F, and G	Temperature Class T5, $T_a = -40^{\circ}\text{C}$ to $+85^{\circ}\text{C}$	F1
FM intrinsically safe for Class I, II, and III, Division 1, Groups A, B, C, D, E, F and G; Zone 0, AEx ia IIC	Temperature Class T4, $T_a = -40^{\circ}\text{C}$ to $+60^{\circ}\text{C}$	F2
FM non-incendive; Class I, II and III, Div 2, Groups A, B, C, D, E, F, and G	Temperature Class T4, $T_a = -40^{\circ}\text{C}$ to $+60^{\circ}\text{C}$	F5

MODEL CODE

<u>Description</u>	<u>Model</u>
Model IDP15D (Draft Range Pressure Transmitter) Measuring Span: 0.4 in to 4 in H ₂ O (0.1 to 1kPa)	IDP15D
Selection I	
Output 4 to 20mA (HART Communication)	B
Fill Fluid Silicone Fluorine (for Oxygen Service)	A H
Cover Material Process Cover: SCS14A, Vent/Drain Plugs: 316SST	A
Wetted Surfaces Material Meterbody: 316SST, Process Diaphragms: 316LSST	A
Process Connections 1/2 in NPT Internal Thread w/ Adapter Flange 1/4 in NPT Internal Thread w/ Adapter Flange 1/4 in NPT Internal Thread w/o Adapter Flange	D E F
Mounting (Process Installation) Horizontal Piping, Front Connection	C
Bolting 304SST	B
Selection II	
Electrical Connection 1/2 in NPT, Watertight M20, Watertight	-A -B
Electrical Safety None FM Explosionproof (a) FM Intrinsically Safe (a), (b) FM Nonincendive (a), (b) FM EX, IS, and NI (a), (b) ATEX Flameproof ATEX Intrinsically Safe (b) ATEX Energy Limited (b) CSA Explosionproof (a) CSA Intrinsically Safe (a), (b)	XX F1 F2 F5 F6 A1 A2 A5 C1 C2
Indicator None With Indicator	X A
Paint Corrosion Proof	B

Model Code continued on next page

MODEL CODE (CONTINUED)

Failure Alarm Configuration	
Upper Limit of Output at Abnormal Condition	A
Lower Limit of Output at Abnormal Condition	B
Mounting Bracket	
None	X
Carbon Steel (Universal)	3
304 SST (Universal)	4
Optional Selections	
No Options	-XX
With External Zero Adjustment (c)	-A2
Long Vent / Drain Plug	-G4
Side Vent / Drain Plug (Top)	-G6
Side Vent / Drain Plug (Bottom)	-G7
Oil/ Water Free Finish	-K1
Oil Free Finish (d)	-K3
Safety Transmitter (e)	-Q1
NAMUR NE43 Compliant	-Q2
Alarm Output (Contact Output)	-Q7
Custom Calibration	-R1
Test Report	-T1
Mill Certificate	-T2
Traceability Certificate	-T4
Non SI Unit	-W1
Example: IDP15D-BAAAECB-AA1ABA3-A2G4Q7	

(a) Not available at this time

(b) Not available with Option "Q7"

(c) Not available with Indicator Code "X"

(d) Not needed when Fill Fluid Code "H" is selected

(e) Not available with Option "A2" or "Q7"

MODEL CODE

<u>Description</u>	<u>Model</u>
Model IDP31D (Standard Differential Pressure Type) Measuring Span: 2 in to 400 in H ₂ O (0.5 to 100kPa)	IDP31D
Selection I Output 4 to 20mA (HART Communication)	B
Filled Fluid Silicone Fluorine (for Oxygen Service)	A H
Cover Material Process Cover: SCS14A, Vent/Drain Plugs: 316SST	A
Wetted Surfaces Material Meterbody: 316SST, Diaphragms: 316LSST Meterbody, Diaphragms: ASTM B575 (Equiv. to Hastelloy C)	A B
Process Connections 1/2 in NPT Internal Thread w/ Adapter Flange 1/4 in NPT Internal Thread, w/ Adapter Flange 1/4 in NPT Internal Thread, w/o Adapter Flange	D E F
Mounting (Process Installation) Horizontal Piping, Front Connection	C
Bolting 304 SST (a) 630 SST	B C
Selection II Electrical Connection 1/2 NPT, Watertight M20, Watertight	-A -B
Electrical Safety None FM Explosionproof (b) FM Intrinsically Safe (b), (c) FM Nonincendive (b), (c) FM EX, IS, and NI (b), (c) ATEX Explosionproof ATEX Intrinsically Safe (c) ATEX Energy Limited (b) CSA Explosionproof (b), (c) CSA Intrinsically Safe (b), (c)	XX F1 F2 F5 F6 A1 A2 A5 C1 C2
Indicator None With Indicator	X A

Model Code continued on next page

MODEL CODE (CONTINUED)

Paint	
Corrosion Proof	B
Failure Alarm Configuration	
Upper Limit of Output at Abnormal Condition	A
Lower Limit of Output at Abnormal Condition	B
Mounting Bracket	
None	X
Carbon Steel (Universal)	3
304 SST (Universal)	4
Optional Selections	
No Option	-XX
Adapters for Anticorrosion materials (g)	-A1
With External Zero Adjustment (d)	-A2
Long Vent / Drain Plug	-G4
Side Vent / Drain Plug (Top)	-G6
Side Vent / Drain Plug (Bottom)	-G7
Oil/ Water Free Finish	-K1
Oil Free Finish (e)	-K3
Safety Transmitter (f)	-Q1
NAMUR NE43 Compliant	-Q2
Alarm Output (Contact Output)	-Q7
Custom Calibration	-R1
Test Report	-T1
Mill Certificate	-T2
Traceability Certificate	-T4
NACE Certificate (h)	-T5
Non SI Unit	-W1
Example: IDP31D-BAAADCC-AA2BBA4-Q2R1	

(a) Max working pressure is restricted to 10MPa when 304SST bolt/nut is selected.

(b) Not available at this time.

(c) Not available with Option "Q7"

(d) Not available with Indicator code X 'None'. Please select code A 'With Indicator'.

(e) No need to select when Fill Fluid code H 'For Oxygen Service' is selected.

(f) Not available with Option A2 'With External Zero Adjustment' or Option Q7 'Alarm Output'.

(g) Required with NACE Certificate (T4 Option) when flange adapters are selected.

(h) Available with Meterbody Material code B "ASTM575" only.

MODEL CODE

<u>Description</u>	<u>Model</u>
Model IDP32D (Standard Differential Pressure Type) Measuring Span: 2 in to 400 in H ₂ O (0.5 to 100 kPa)	IDP32D
Selection I	
Output	
4 to 20mA (HART Communication)	B
Filled Fluid	
Silicone	A
Fluorine (for Oxygen Service)	H
Cover Material	
Process Cover: SCS14A, Vent/Drain Plugs: 316SST	A
Wetted Surfaces Material	
Meterbody: 316SST, Diaphragms: 316LSST	A
Process Connections	
1/4 in NPT Internal Thread, w/o Adapter Flange	F
Mounting (Process Installation)	
Vertical Piping, Top Connection	A
Bolting	
304 SST (a)	B
630 SST	C
Selection II	
Electrical Connection	
1/2 NPT, Watertight	-A
M20, Watertight	-B
Electrical Safety	
None	XX
FM Explosionproof (b)	F1
FM Intrinsically Safe (b), (c)	F2
FM Nonincendive (b), (c)	F5
FM EX, IS, and NI (b), (c)	F6
ATEX Explosionproof	A1
ATEX Intrinsically Safe (c)	A2
ATEX Energy Limited (b)	A5
CSA Explosionproof (b), (c)	C1
CSA Intrinsically Safe (b), (c)	C2
Indicator	
None	X
With Indicator	A
Paint	
Corrosion Proof	B

Model Code continued on next page

MODEL CODE (CONTINUED)

<u>Failure Alarm Configuration</u>	
Upper Limit of Output at Abnormal Condition	A
Lower Limit of Output at Abnormal Condition	B
<u>Mounting Bracket</u>	
None	X
Carbon Steel (Flat shape)	3
304 SST (Flat shape)	4
<u>Optional Selections</u>	
No Option	-XX
With External Zero Adjustment (d)	-A2
Long Vent / Drain Plug	-G4
Oil/ Water Free Finish	-K1
Oil Free Finish (e)	-K3
Safety Transmitter (f)	-Q1
NAMUR NE43 Compliant	-Q2
Alarm Output (Contact Output)	-Q7
Custom Calibration	-R1
Test Report	-T1
Mill Certificate	-T2
Traceability Certificate	-T4
Non SI Unit	-W1
Example: IDP32-BAAAFCB-AXXBBA4-A2	

(a) Max working pressure is restricted to 10 MPa when 304 SST bolt/nut is selected.

(b) Not available at this time.

(c) Not available with Option "Q7".

(d) Not available with Indicator code X 'None'. Please select code A 'With Indicator'.

(e) No need to select when Fill Fluid code H 'For Oxygen Service' is selected.

(f) Not available with Option A2 'With External Zero Adjustment' or Option Q7 'Alarm Output'.

DIMENSIONS-NOMINAL

Model IDP15D

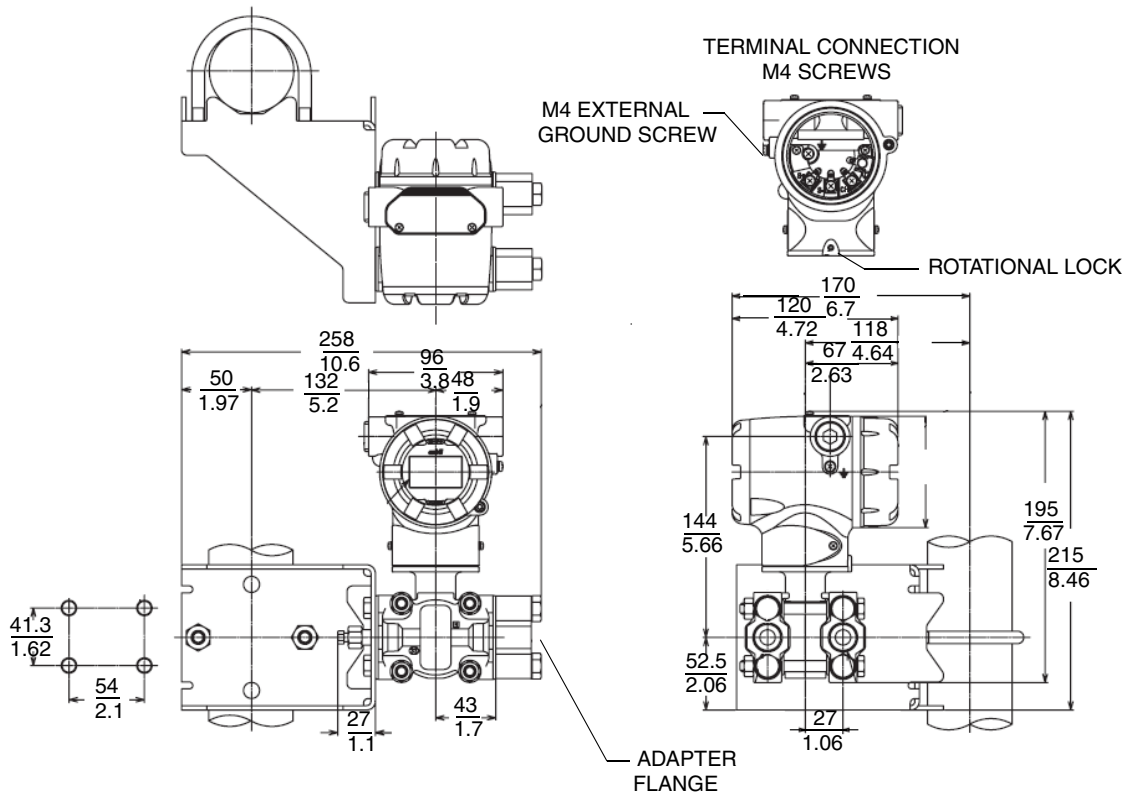

DIMENSIONS-NOMINAL (CONT.)

Model IDP15D (Continued)

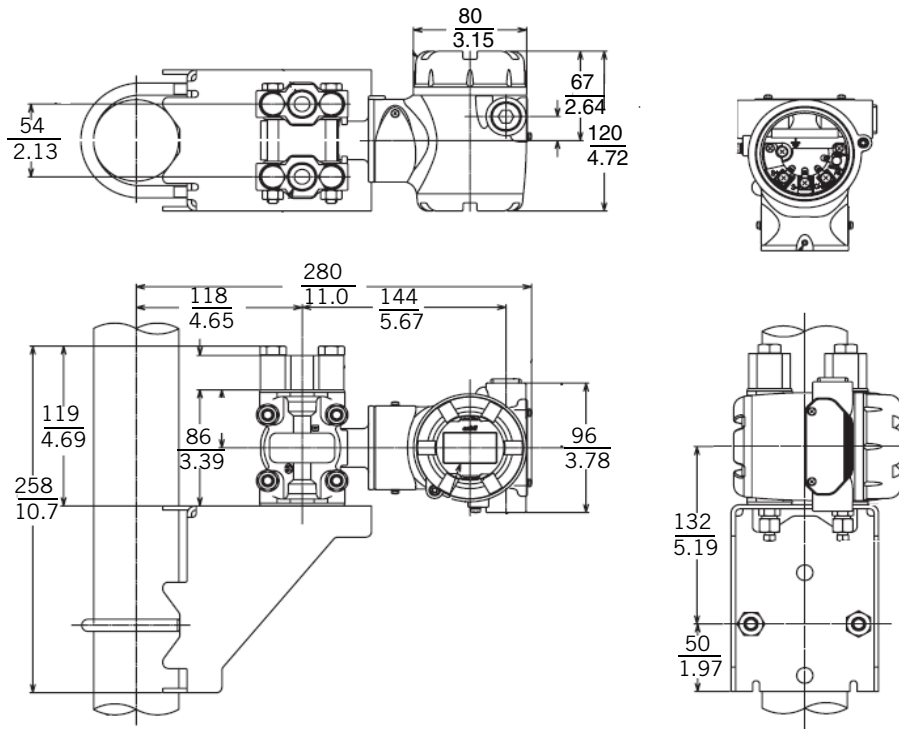

DIMENSIONS-NOMINAL (CONT.)

Model IDP31D

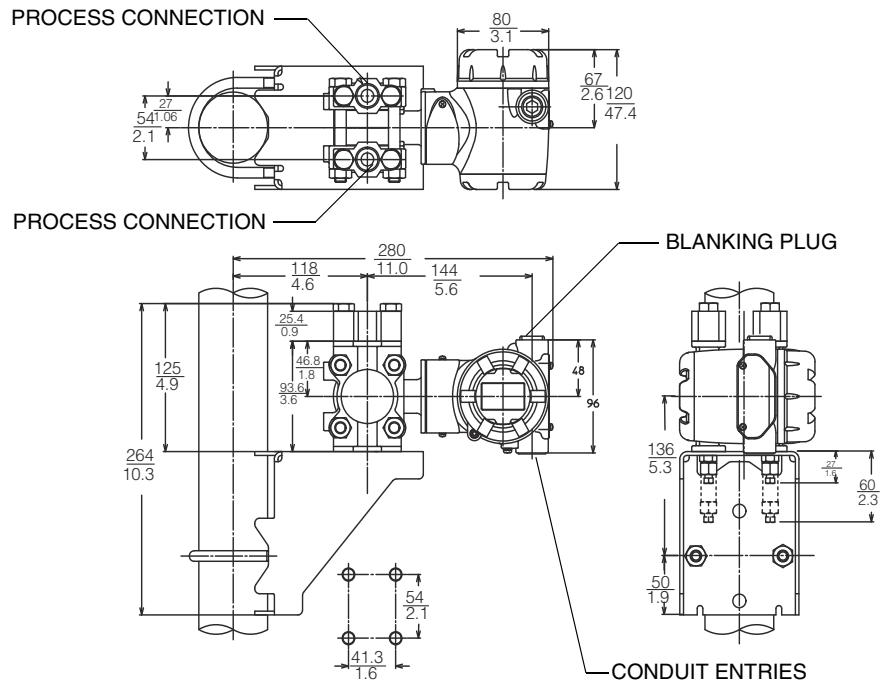
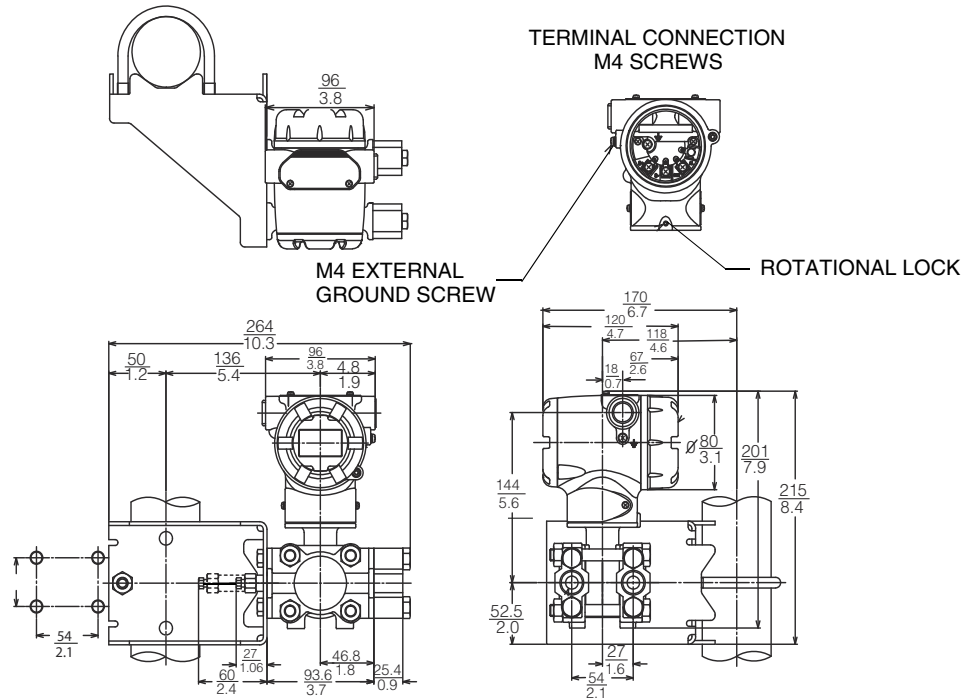

DIMENSIONS-NOMINAL (CONT.)

Model IDP32D

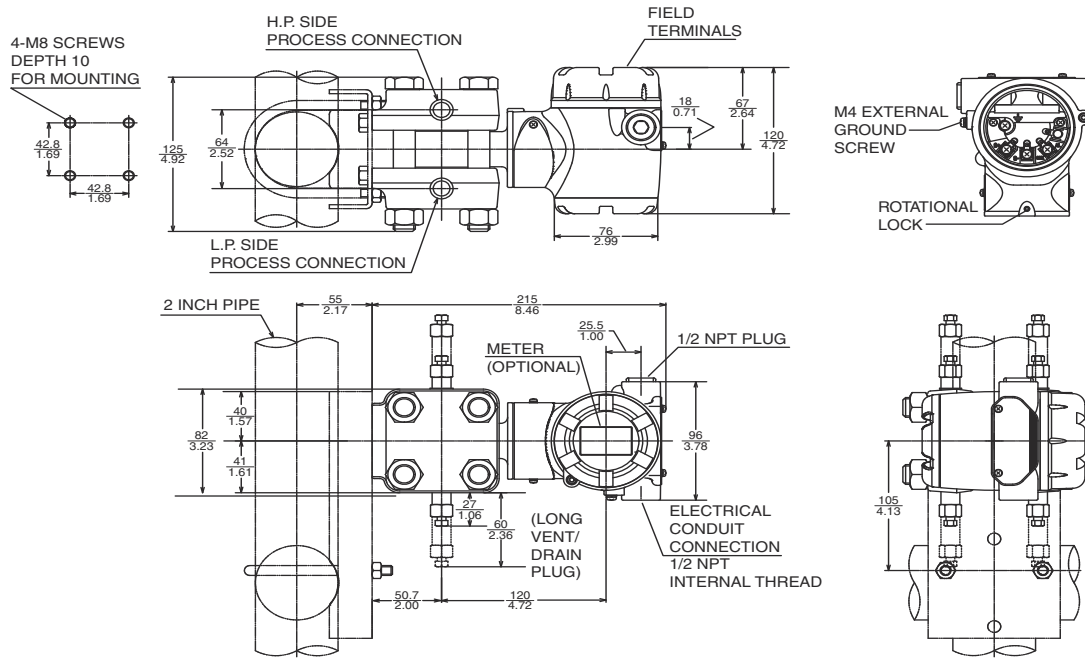

ORDERING INSTRUCTIONS

1. Model Number(s) as follows:
 - Transmitter only, if pressure seals are not selected
 - Both transmitter and pressure seals, if pressure seals are selected with traditional structure. See PSS 2A-1Z11 A.
2. Calibrated Pressure Range using Allowable Pressure Units from the table below.

inH ₂ O	inHg	Pa	mbar	psia
ftH ₂ O	mmHg	kPa	bar	atm
mmH ₂ O		MPa	g/cm ²	
		torr	kg/cm ²	

3. Configuration Data Form when Factory Calibration Option -C2 is specified.
4. If Option -S2 (SIL-Certified HART Transmitter) is selected, a copy of the certification can be provided by specifying AS Code CERT-L.
5. Options and Accessories not in Model Code (see PSS 2A-1Z9 E).
6. User Tag Data - Data Plate; 32 characters maximum. For additional tag data, specify Optional Supplemental Tag -T.
7. User Tag Data - Software (Database); 8 characters maximum (user configured).

OTHER M&I PRODUCTS

Invensys provides a broad range of measurement and instrument products, including solutions for pressure, flow, analytical, positioners, temperature, controlling and recording. For a listing of these offerings, visit the Invensys Operations Management web site at:

www.iom.invensys.com

Invensys Operations Management
5601 Granite Parkway Suite 1000
Plano, TX 75024
United States of America
<http://iom.invensys.com>

Global Customer Support
Inside U.S.: 1-866-746-6477
Outside U.S.: 1-508-549-2424 or contact
your local Invensys representative.
Email: iom.support@invensys.com
Website: <http://support.ips.invensys.com>

Invensys and Foxboro are trademarks of
Invensys plc, its subsidiaries, and affiliates.
All other brand names may be trademarks of their
respective owners.

Copyright 2010-2011 Invensys Systems, Inc.
All rights reserved

MB 010