

**Models IAP10, IGP10, IAP20, IGP20, and IDP10 I/A Series<sup>®</sup> Absolute, Gauge, and Differential Pressure Transmitters with FOUNDATION<sup>™</sup> Fieldbus Communication Protocol - FISCO/FNICO Compliant**



*The Foxboro brand Models IAP10, IGP10, IAP20, IGP20, and IDP10 are FISCO/FNICO compliant transmitters that provide precise, reliable measurement of absolute, gauge, or differential pressure. They receive power from, and communicate digitally over, the FOUNDATION<sup>™</sup> Fieldbus segment. DDs, filled with the Foundation, are supplied to ensure operability with any Host supporting Fieldbus communication protocol.*

**FEATURES**

- ▶ FOUNDATION Fieldbus 31.25 kbits/s, Voltage Mode; MAU (Media Access Unit) specification compliant for intrinsic safety.
- ▶ FISCO/FNICO compliant.
- ▶ Interoperability tested – Foundation registered.
- ▶ Transmitter includes Fieldbus Function Blocks.
- ▶ Digital precision, stability, and resolution ensure top measurement performance.
- ▶ Silicon strain gauge sensors successfully field-proven in many thousands of installations.
- ▶ Multidrop Fieldbus supports point-to-point, bus, and tree topologies up to 1900 m (6235 ft).
- ▶ Wiring savings in existing installations when mixing fieldbus segments with 4 to 20 mA wires.
- ▶ Can be provided with numerous configurations of direct connect or remote mount seals.
- ▶ Traditional or low profile structures available with the IDP10 Transmitter (see photos above).
- ▶ Remote access to all transmitter parameters for less maintenance and easier record keeping.
- ▶ Transmitter configuration locally via the LCD Indicator, or remotely over Fieldbus.
- ▶ Supports all standard views, alarm messages, and trends.
- ▶ Dual Seal certified to meet ANSI/ISA 12.27.01-2003 requirements.

- ▶ CE marked; complies with applicable EMC, ATEX, and PED European Directives.
- ▶ Enclosure meets NEMA 4X and IEC IP66 ratings.
- ▶ Meet numerous Agency requirements for hazardous locations. Versions available to meet Agency flameproof and zone requirements.
- ▶ Numerous mounting bracket set options.
- ▶ Many other options and accessories offered to expand the capabilities of these transmitters.
- ▶ Standard 5-year warranty.

### I/A Series® PRESSURE TRANSMITTER FAMILY

These FISCO compliant transmitters are part of a complete family of d/p Cell®, gauge, absolute, multirange, multivariable, and premium performance transmitters, as well as transmitters with remote or direct connect pressure seals, all using field proven silicon strain gauge sensors and common topworks.

### FOUNDATION FIELDBUS TECHNOLOGY

The FOUNDATION Fieldbus is an all digital, serial, two-way communication system which interconnects field devices, such as transmitters, actuators, and controllers. It is a Local Area Network (LAN) with built-in capability to distribute control application across the network. This technology consists of the Physical Layer, the Communication Stack, and the User Application Blocks.

#### Physical Layer Standards

The Fieldbus Foundation specification FF816 uses IEC 1158-2 and ISA S50.02 Physical Layer Standards as references to define, as a minimum, the signaling and electrical properties of a fieldbus device's Physical Layer interface. The properties of these transmitters are:

- ▶ Polarity Independent
- ▶ Open Circuit Level of 35 V dc maximum
- ▶ Intrinsically Safe Parameters per the following table.

| Parameter            | Recommended Value |
|----------------------|-------------------|
| Approval Voltage     | 24 V dc           |
| Approval Current     | 250 mA            |
| Input Power          | 1.2 W             |
| Residual Capacitance | < 5 nF            |
| Residual Inductance  | < 20 µH           |

#### Communication Stack

The Communication Stack comprises a Data Link Layer (DLL), a Fieldbus Access Sublayer (FAS), and a Fieldbus Message Specification (FMS).

#### The Data Link Layer (DLL)

- ▶ Scheduled Communication – As authorized by the Link Access Scheduler (LAS).
- ▶ Device can be assigned an LAS, if required.
- ▶ Unscheduled Communication – This allows all devices on the fieldbus to send “unscheduled” messages between the transmission of scheduled messages.

### The Fieldbus Access Sublayer (FAS)

- ▶ Client/Server VCR (Virtual Communication Relationship) – This is used for queued, unscheduled, user-initiated, one-to-one communication between the devices on the fieldbus; typically user-initiated requests, such as setpoint changes, alarm acknowledgments, and device uploads/downloads.
- ▶ Report Distribution VCR – Typically allows fieldbus devices to send alarm notifications to operator console.
- ▶ Publisher/Subscriber VCR – Allows fieldbus device to publish data, and send function block I/O data, such as process variable (PV) and primary output data to operator console.

### The Fieldbus Message Specification (FMS)

FMS services allow users to send messages to each other across the fieldbus. The FMS describes communication services, message formats, and protocol required for the user application.

### User Application Blocks

These software blocks represent different user functions, such as analog input (AI) and proportional, integral, derivative (PID) Function Blocks.

### Analog Input Function Block

The AI function blocks contain all configurable parameters needed to define the input data for use with other function blocks. Parameters include revision level, tag description, alarms, process variables, transducer scale values, and strategy.

### Proportional, Integral, Derivative Function Block

A single PID function block contains all the standard parameters required to implement a general purpose, automatic PID control scheme.

## DEVICE ADDRESS ASSIGNMENT

Each device is assigned an ID (comprising at least a tag and address) via a configurator. A “Find Tag Service” initiates a tag search for the convenience of host systems and maintenance devices.

## DEVICE DESCRIPTORS (DDs)

DD and function block parameters allow device interoperability. The DD allows the host to interpret device data, including calibration and diagnostics. The Fieldbus Foundation provides standard DDs, while the device manufacturer provides “incremental” DDs. Standard and incremental DDs are read directly from the device over fieldbus.

## FIELDBUS CHARACTERISTICS

| Parameter                    | Specification        |     |
|------------------------------|----------------------|-----|
|                              | No                   | Yes |
| Intrinsically Safe           | No                   | Yes |
| Maximum No. of Devices (a)   | 32                   | 6   |
| Maximum Total Bus Length (b) | 1900 m (6235 ft) (b) |     |
| Maximum Spur Length (b) (c)  | 120 m (395 ft) (c)   |     |

- a. Maximum number of devices may be less depending on device power consumption, type of cable used, addition of accessory devices such as repeaters, etc.
- b. Total bus length including all spurs is based on use of #18 AWG (0.8 mm<sup>2</sup>) shielded twisted pair cable. See Installation Manual for the precise relationship between cable length, spur lengths, cable type, and number of devices.
- c. Maximum spur length is as listed. However, for hybrid installations, the maximum intrinsically safe (I.S.) spur length is dependent on the field barrier used. For I.S. installations, the maximum spur length is 30 m (98 ft). Minimum spur length is 1 m (3.3 ft).

## BUS SIZING PARAMETERS

- ▶ Current Consumption: 19.5 mA, nominal
- ▶ Minimum Voltage: 9 V dc
- ▶ Virtual Communication Relationships: 20 VCR

## FIELDBUS DEVICE INSTALLATION TOPOLOGIES

Typical installation topologies are shown in Figure 1 and Figure 2, including a bus with spurs, a daisy chain, and a tree. These installations are shown in parallel and series configurations.

### Bus With Spurs Topology

Devices connected to bus segment via a spur. The spur cable can vary in length to 120 m (394 ft). The length of the spur can limit the total fieldbus length.

### Daisy Chain Topology

Fieldbus cable routed from device to device on the same segment. Installation practices should ensure that one device can be disconnected without disrupting the continuity of the segment.

### Tree Topology

Devices on a single segment are connected to a common junction box using individual twisted pair wire. Maximum spur lengths must be considered.

### Mixed Topology

Mixed topologies allow the connection of other topologies in a series configuration. A mixed topology, although not often used, must follow the rules relating to total fieldbus length.

### OUTPUT SIGNAL

Digital, serial, two-way communication system that runs at 31.25 kbits/s. The signal is superimposed on the bus dc power signal, and controlled by a strict cycle schedule and protocol.

### SUPPLY VOLTAGE

9 to 32 V dc, by a specific fieldbus power source connected to the bus. For intrinsically safe (I.S.) applications, the supply voltage allowed can vary depending on the rating of the I.S. barrier.

### SUPPLY VOLTAGE EFFECT

Output changes <0.005% of calibrated span for each 1 V change within the specified supply voltage.

### MOUNTING POSITION

The transmitter may be mounted in any orientation.

### MOUNTING POSITION - ZERO EFFECT

Eliminated by rezeroing; there is no span effect.

### FIELD WIRING REVERSAL

Polarity independent; either connection acceptable.

### MICROPROCESSOR-BASED ELECTRONICS

Provides excellent accuracy and ambient temperature compensation.

### RFI EFFECT

Output error is <0.1% of calibrated span for radio frequencies from 27 to 1000 MHz and field intensity of 30 V/m when transmitter is properly installed, shielded cable in conduit, grounding, and housing covers in place. (Per IEC Std. 61000-4-3.)

### SWITCHING AND INDIRECT LIGHTNING TRANSIENTS

Transmitter withstands transient surges to 2000 V common mode or 1000 V normal mode without permanent damage. Output shift is less than 1.0%. (Per ANSI/IEEE C62.41-1980 and IEC Std. 61000-4-5.)

Figure 1. Miscellaneous Installation Topologies

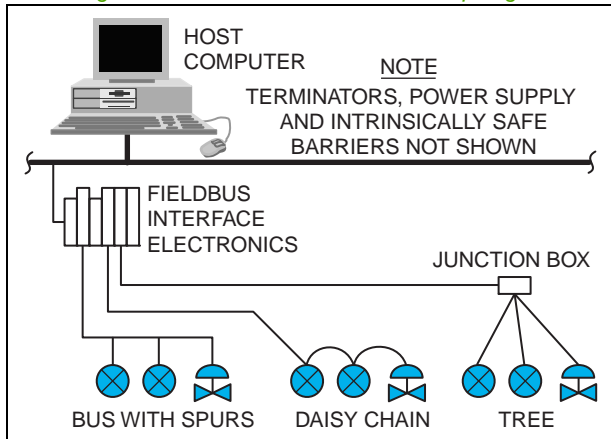
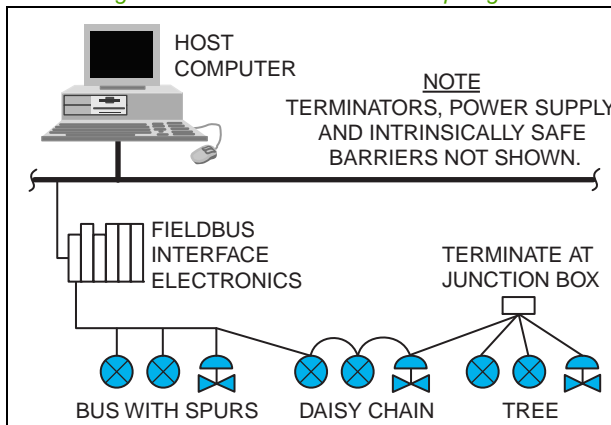

Figure 2. Installation with Mixed Topologies



### EUROPEAN UNION DIRECTIVES

- ▶ Complies with Electromagnetic Compatibility Requirements of European EMC Directive 2004/108/EC by conforming to the following EN and IEC Standards: EN 61326-1, and IEC 61000-4-2 through 61000-4-6.
- ▶ Complies with NAMUR NE 21 Interference Immunity Requirement, and NAMUR NE 43 overrange and underrange annunciations.
- ▶ Conforms to Applicable European Union Directives ("CE" Logo marked on product).

### ENVIRONMENTAL PROTECTION

The enclosure has the dusttight and weatherproof rating of IP66 as defined by IEC 60529, and provides the environmental and corrosion resistant protection rating of NEMA 4X.

### ELECTRONICS HOUSING AND HOUSING COVERS

Housing has two compartments to separate the electronics from the field connections. The housing and covers are made from low copper (0.6% maximum) die-cast aluminum alloy with an epoxy finish, or from 316 ss. Buna-N O-rings are used to seal the threaded housing covers, housing neck, and terminal block.

### ELECTRONICS MODULE

Printed wiring assemblies (PWAs) are conformally coated for moisture and dust protection.

### EASE OF INSTALLATION

Rotatable Topworks allows transmitter installation in tight places, allows indicator to be positioned in preferred direction, and eases field retrofit.

Two Conduit Entrances offer a choice of entry positions for ease of installation and self-draining of condensation regardless of mounting position and topworks rotation.

Wiring Guides and Terminations provide ease of wire entry and support, plenty of space to work and store excess wire, and large, rugged screw terminals for easy wire termination.

### MINIMUM ALLOWABLE ABSOLUTE PRESSURE VS. TRANSMITTER TEMPERATURE

#### With Silicone Fill Fluid

Full vacuum: up to 121°C (250°F)

#### With Inert Fill Fluid

*Figure 3. Minimum Allowable Absolute Pressure vs. Transmitter Temperature, Inert FC-43, 2.6 cSt at 25°C (77°F)*

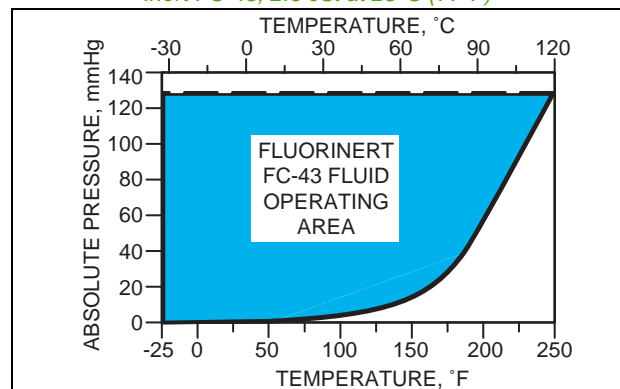

### ELECTRICAL TERMINATIONS

Field wires enter through 1/2 NPT, PG 13.5, or M20 threaded entrances on either side of the electronics housing. Wires terminate at a polarity independent terminal block in the field terminal compartment, and the wire shield can terminate at the ground screw, shown in Figure 4. Unused entrance is plugged to ensure moisture and RFI/EMI protection.

Figure 4. Field Terminal Connections

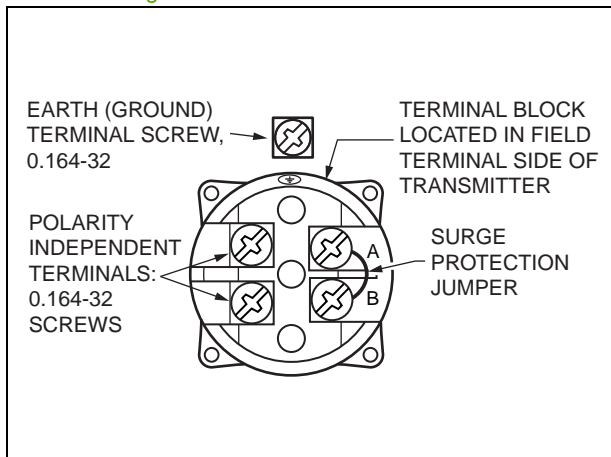

### ADJUSTABLE DAMPING

Response time is normally 0.75 s, or electronically adjustable setting of 0 (none), 0.25, 0.50, 1, 2, 4, 8, 16, or 32 seconds, whichever is greater, for a 90% recovery from an 80% input step as defined in ANSI/ISA S51.1. (For 63.2% recovery, 0.50 s with sensors B to F, and 0.60 s for sensor A.) Damping can also be set in both the Transducer and AI Blocks.

### OPTIONAL LCD INDICATOR

Indicator provides:

- ▶ Two Lines; five numeric characters on top line (four when a minus sign is needed) and seven alphanumeric characters on bottom line.
- ▶ Measurement Readout; value on top line and units label on bottom line.
- ▶ Configuration and Calibration Prompts.

Figure 5. LCD Indicator with Pushbuttons

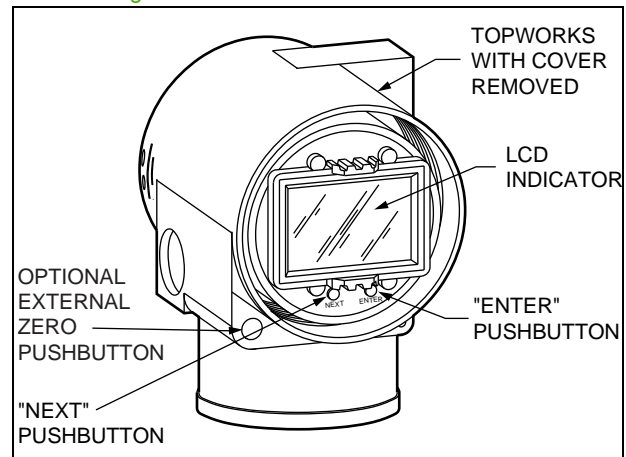

### OPTIONAL EXTERNAL ZERO ADJUSTMENT

A pushbutton mechanism (Figure 5) is isolated from the electronics and magnetically activates a reed switch internal to the housing. This eliminates a potential leak path for moisture or contaminants to get into the electronics compartment. This zero adjustment can be disabled by a configuration selection.

### SUPPRESSED ZERO AND ELEVATED ZERO RANGES

These ranges are acceptable as long as the Span and Range limits are not exceeded. Elevated zero applies to IGP20 and IDP10 Transmitters only.

### ZERO AND SPAN ADJUSTMENTS

Zero/span adjustments can be accomplished using the pushbuttons on the LCD Indicator (see Figure 5).



### OPTIONAL TRANSMITTER MOUNTING BRACKET SETS

Numerous mounting bracket set options are offered to accommodate almost any mounting configuration required. See "DIMENSIONS - NOMINAL" on page 39.

### CONFIGURATION AND CALIBRATION DATA AND ELECTRONIC UPGRADEABILITY

All factory characterization data, and user configuration and calibration data, are stored in the sensor. This means that the electronics module can be replaced, with one of like type, without the need for reconfiguration or recalibration.

Changing module types (from one protocol to another) may require reconfiguration and recalibration, as well as a different terminal block, but all factory characterization data is retained.

### HOST/TRANSMITTER COMMUNICATION

You may monitor, configure, and calibrate your transmitter using the following:

- ▶ The Optional Liquid Crystal Display (LCD) Indicator with On-Board Pushbuttons (Figure 5)
- ▶ FOUNDATION Fieldbus Host consisting of an I/A Series System Workstation having a FOUNDATION Fieldbus interface electronics PWA
- ▶ FOUNDATION Fieldbus Host consisting of a PC equipped with a FOUNDATION Fieldbus interface electronics PWA
- ▶ Any other Fieldbus certified host.

### REMOTE COMMUNICATION

Using FOUNDATION fieldbus protocol, transmitter communications includes the following:

- ▶ Resource State
- ▶ Manufacturer ID
- ▶ Device Type, Revision
- ▶ DD Resource, Revision
- ▶ Resource Diagnostic Parameters
- ▶ Output in % or EGU (Engineering Units)
- ▶ Zero and Span, including Reranging
- ▶ Zero Elevation or Suppression
- ▶ Linear or Square Root Output
- ▶ Pressure EGU
- ▶ Electronic Damping
- ▶ External Zero Enable or Disable
- ▶ Resource Diagnostic
- ▶ Alarms
- ▶ Calibration
- ▶ Date of Last Calibration
- ▶ Calibrator's Name

**PRESSURE SEALS**

Pressure seals are used with the I/A Series Transmitters when it is necessary to keep the transmitter isolated from the process. A sealed system is used for a process fluid that may be corrosive, viscous, subject to temperature extremes, toxic, sanitary, or tend to collect and solidify.

Table 1 and Table 2 lists the various pressure seals that can be used with these transmitters. To order a transmitter with seals, both a Transmitter Model Number and Seal Model Number are required. See PSS 2A-1Z11 A for a complete listing of pressure seal models and specifications. Also see Figure 6 for typical pressure seal configurations.

**Table 1. Pressure Seals Used with I/A Series Pressure Transmitters**

| Seal Model  | Seal Description   | Process Connections  |
|---|--|--|
| <b>Direct Connect Pressure Seal Assemblies</b>                    |  |  |
| PSFLT   | Flanged, Direct Connect (Flanged Level), Flush or Extended Diaphragm | ANSI Class 150/300/600 flanges and BS/DIN PN 10/40, 10/16, 25/40 flanges                 |
| PSFAD   | Flanged, Direct Connect, Recessed Diaphragm                          | ANSI Class 150, 300, 600, 1500 flanges   |
| PSFFD   | Flanged, Direct Connect, Flush Diaphragm (IAP10 and IGP10 only)      | ANSI Class 150, 300, 600 and PN 10/40  |
| PSTAD   | Threaded, Direct Connect, Recessed Diaphragm                         | 1/4, 1/2, 3/4, 1, or 1 1/2 NPT internal thread   |
| PSISD   | In-Line Saddle Weld, Direct Connect, Recessed Diaphragm              | Lower housing of seal is in-line saddle welded to nominal 3- or 4-inch (and larger) Pipe |
| PSSCT   | Sanitary, Direct Connect (Level Seal), Flush Diaphragm               | Process Connection to Sanitary Piping with 2- or 3-inch Tri-Clamp                        |
| PSSST   | Sanitary, Direct Connect (Level Seal), Extended Diaphragm            | Process Connection to 2-in Mini Spud or 4-in Standard Spud; Tri-Clamp                    |
| <b>Remote Mount, Capillary-Connected Pressure Seal Assemblies</b> |  |  |
| PSFPS   | Flanged, Remote Mount, Flush Diaphragm                               | ANSI Class 150/300/600 flanges and BS/DIN PN 10/40 flanges                               |
| PSFES   | Flanged, Remote Mount, Extended Diaphragm                            | ANSI Class 150/300/600 flanges and BS/DIN PN 10/40, 10/16, 25/40 flanges                 |
| PSFFR   | Flanged, Remote Mount, Flush Diaphragm                               | ANSI Class 150, 300, 600 flanges and DIN/BS PN 10/40                                     |
| PSFAR   | Flanged, Remote Mount, Recessed Diaphragm                            | ANSI Class 150/300/600/1500 flanges  |
| PSTAR   | Threaded, Remote Mount, Recessed Diaphragm                           | 1/4, 1/2, 3/4, 1, or 1 1/2 NPT internal thread   |
| PSISR   | In-Line Saddle Weld, Remote Mount, Recessed Diaphragm                | Lower housing of seal is in-line saddle welded to nominal 3- or 4-inch (and larger) Pipe |
| PSSCR   | Sanitary, Remote Mount, Flush Diaphragm                              | Process Connection secured with a Tri-Clamp to a 2- or 3-inch pipe                       |
| PSSSR   | Sanitary, Remote Mount, Extended Diaphragm                           | Process Connection to 2-in Mini Spud or 4-in Standard Spud; Tri-Clamp                    |



Table 2. I/A Series Pressure Transmitters and Applicable Pressure Seals

| Transmitter Model | Used with Pressure Seal Model: (a) |     |     |     |     |     |     |     |     |     |     |     |     |     |     |
|-------------------|------------------------------------|-----|-----|-----|-----|-----|-----|-----|-----|-----|-----|-----|-----|-----|-----|
|                   | FLT                                | FAD | FFD | TAD | ISD | SCT | SST | FPS | FES | FAR | FFR | TAR | ISR | SCR | SSR |
| IAP10             | -                                  | ✓   | ✓   | ✓   | ✓   | -   | -   | ✓   | ✓   | ✓   | ✓   | ✓   | ✓   | ✓   | ✓   |
| IGP10             | -                                  | ✓   | ✓   | ✓   | ✓   | -   | -   | ✓   | ✓   | ✓   | ✓   | ✓   | ✓   | ✓   | ✓   |
| IAP20             | -                                  | -   |     | -   | -   | -   | -   | ✓   | ✓   | ✓   | ✓   | ✓   | ✓   | ✓   | ✓   |
| IGP20             | ✓                                  | -   |     | -   | -   | ✓   | ✓   | ✓   | ✓   | ✓   | ✓   | ✓   | ✓   | ✓   | ✓   |
| IDP10 (b)         | ✓                                  | -   |     | -   | ✓   | ✓   | ✓   | ✓   | ✓   | ✓   | ✓   | ✓   | ✓   | ✓   | ✓   |

- a. Pressure Seal models are shown with an abbreviated code; all seal codes have a PS prefix; for example, FLT is PSFLT.
- b. Pressure seals are used with IDP10 Transmitters having a traditional structure only.

Figure 6. Transmitter with Typical Pressure Seal Configurations



OPERATING, STORAGE, AND TRANSPORTATION CONDITIONS

| Influence   | Ref. Operating Conditions                                | Normal Operating Conditions (b)  | Operative Limits (a) (b)   | Transportation and Storage Limits  |
|---|--|--|--|--|
| Process Connection Temp.<br>▶ with Silicone Fill Fluid<br><br>▶ with Inert Fill Fluid | ▶ 24 ± 2°C<br>(75 ± 3°F)<br><br>▶ 24 ± 2°C<br>(75 ± 3°F) | ▶ -29 to + 82°C<br>(-20 to +180°F)<br><br>▶ -29 to + 82°C<br>(-20 to +180°F)   | ▶ -46 and +121°C (c)<br>(-50 and +250°F) (c)<br><br>▶ -29 and +121°C<br>(-20 and +250°F)       | ▶ Not Applicable<br><br>▶ Not Applicable   |
| Electronics Temperature<br><br>▶ with LCD Indicator (d)                               | ▶ 24 ± 2°C<br>(75 ± 3°F)<br><br>▶ 24 ± 2°C<br>(75 ± 3°F) | ▶ -29 to + 82°C (e)<br>(-20 to +180°F)<br>(h)<br><br>▶ -20 to + 82°C (e)<br>(-4 to +180°F) (e)   | ▶ -40 and +85°C (e)<br>(-40 and +185°F) (e)<br><br>▶ -29 and +85°C (e)<br>(-20 and +185°F) (e) | ▶ -54 and +85°C<br>(-65 and +185°F)<br><br>▶ -54 and +85°C<br>(-65 and +185°F)   |
| Relative Humidity (f)   | 50 ± 10%   | 0 to 100%  | 0 and 100%   | 0 and 100% (f)   |
| Supply Voltage (g)  | 30 ± 0.5 V dc  | 9 to 32 V dc   | 9 and 32 V dc  | Not Applicable   |
| Vibration   | 1 m/s <sup>2</sup><br>(0.1 "g")                          | 6.3 mm (0.25 in) Double Amplitude:<br>from 5 to 15 Hz with Aluminum Housing and from<br>5 to 9 Hz with 316 ss Housing<br>-----<br>0 to 30 m/s <sup>2</sup> (0 to 3 "g") from 15 to 500 Hz with<br>Aluminum Housing; and<br>0 to 10 m/s <sup>2</sup> (0 to 1 "g") from 9 to 500 Hz with<br>316 ss Housing |  | 11 m/s <sup>2</sup><br>(1.1 "g")<br>from 2.5 to 5 Hz<br>(in Shipping<br>Package) |
| Mounting Position   | Upright (g)  | Upright (h)  | No Limit   | Not Applicable   |

- a. Temperature limits are derated for the IAP20, IGP20, and IDP10 Transmitters:  
to -7 and +82°C (20 and 180°F) when Structure Codes 78/79 (pvdf inserts) are used, and  
to 0 and 60°C (32 and 140°F) when DIN Construction Options D2/D4/D6/D8 are used.
- b. Normal Operating Conditions and Operative Limits are defined per ANSI/ISA 51.1-1979 (R1993).
- c. Selection of Option -J extends the low temperature operative limit of transmitters with silicone filled sensors down to -50°C (-58°F).  
Performance is not assured below -29°C. Sensor damage may occur if process is frozen.
- d. Although the LCD will not be damaged at any temperature within the "Storage and Transportation Limits," updates will be slowed and  
readability decreased at temperatures outside the "Normal Operating Conditions"
- e. Refer to "ELECTRICAL SAFETY SPECIFICATIONS – IAP10 AND IGP10 TRANSMITTERS" on page 11 for a restriction in ambient  
temperature with certain electrical certifications.
- f. With topworks covers on and conduit entrances sealed. Storage/Transportation Limits noncondensing.
- g. Power supplied by a specific Fieldbus power supply.
- h. Sensor process wetted diaphragms in a vertical plane for IAP20 and IGP20 Transmitter.

**ELECTRICAL SAFETY SPECIFICATIONS – IAP10 AND IGP10 TRANSMITTERS**

Transmitters have been designed to meet the Electrical Specifications listed in the tables that follow. Contact Global Customer Support for information or status of testing lab approvals or certifications.

See "" on page 17 for availability of Electrical Safety Design Codes with Transmitter Structure Codes.

| Testing Laboratory, Types of Protection, and Area Classification   | Application Conditions  | Electrical Safety Design Code |
|--|---|-------------------------------|
| ATEX flameproof; II 2 GD, EEx d IIC, Zone 1.   | Temperature Class T6, Ta = -40°C to +75°C.  | D                             |
| ATEX FISCO field device intrinsically safe; II 1 G, EEx ia IIC, Zone 0.  | Temperature Class T4, Ta = -40°C to +80°C.  | E                             |
| ATEX FNICO field device protection n; II 3 G, EEx nL IIC, Zone 2.  | Temperature Class T4, Ta = -40°C to +80°C.  | N                             |
| CSA FISCO field device intrinsically safe for Class I, Division 1, Groups A, B, C, and D; Class II, Division 1, Groups E, F, and G; Class III, Division 1.<br><br>Also zone certified intrinsically safe Ex ia IIC, and energy limited Ex nA II. | Temperature Class T6 at 40°C, and T4A at 85°C maximum ambient.<br><br>Temperature Class T4 at 40°C, and T3 at 85°C maximum ambient. | C                             |
| CSA explosionproof for Class I, Division 1, Groups B, C, D; and dust-ignitionproof for Class II, Division 1, Groups E, F, and G; and Class III, Division 1.  | Maximum Ambient Temperature 85°C.   | C                             |
| CSA FNICO field device Class I, Division 2, Groups A, B, C, and D; Class II, Division, 2, Groups F and G; and Class III, Division 2.   | Temperature Class T6 at 40°C and T4A at 85°C maximum ambient.   | C                             |
| CSA field device zone certified flameproof, Ex d IIC.<br>Also, all certifications of Code C above.   | Maximum Ambient Temperature 85°C.   | B                             |
| FM FISCO field device intrinsically safe for Class I, Division 1, Groups A, B, C, and D; Class II, Division 1, Groups E, F, and G; Class III, Division 1.<br><br>Also zone approved intrinsically safe AEx ia IIC.                               | Temperature Class T4A at 40°C and T4 at 85°C maximum ambient.<br><br>Temperature Class T4 at 85°C maximum ambient.                  | F                             |
| FM explosionproof for Class I, Division 1, Groups B, C, and D; and dust-ignitionproof for Class II, Division 1, Groups E, F, and G; and Class III, Division 1.   | Temperature Class T6 at 80°C and T5 at 85°C maximum ambient.  | F                             |
| FM FNICO field device nonincendive Class I, Division 2, Groups A, B, C, and D; Class II, Division 2, Groups F and G, and Class III, Division 2.  | Temperature Class T4A at 40°C and T4 at 85°C maximum ambient.   | F                             |
| FM field device zone approved flameproof, AEx d IIC.<br>Also, all certifications of Code F above.  | Temperature Class T6 at 75°C maximum ambient.   | G                             |
| IECEX FISCO field device intrinsically safe, Ex ia IIC, Zone 0.  | Temperature Class T4, Ta = -40°C to +80°C.  | T                             |
| IECEX flameproof, Ex d IIC, Zone 1.  | Temperature Class T6, Ta = -40°C to +75°C.  | V                             |
| IECEX FNICO field device protection n, Ex nL IIC, Zone 2.  | Temperature Class T4, Ta = -40°C to +80°C.  | U                             |

**ELECTRICAL SAFETY SPECIFICATIONS – IAP20 AND IGP20 TRANSMITTERS**

Transmitters have been designed to meet the Electrical Specifications listed in the tables that follow. Contact Global Customer Support for information or status of testing lab approvals or certifications.

See “MODEL CODE: IAP20 AND IGP20 TRANSMITTERS” on page 24 for availability of Electrical Safety Design Codes with Transmitter Structure Codes.

| Testing Laboratory, Types of Protection, and Area Classification   | Application Conditions  | Electrical Safety Design Code |
|--|---|-------------------------------|
| ATEX flameproof; II 2 GD, EEx d IIC, Zone 1.   | Temperature Class T6, T85°C, Ta = -40°C to +80°C.   | D                             |
| ATEX FISCO field device intrinsically safe; II 1 G, EEx ia IIC, Zone 0.  | Temperature Class T4, Ta = -40°C to +80°C.  | E                             |
| ATEX FNICO field device protection n; II 3 G, EEx nL IIC, Zone 2.  | Temperature Class T4, Ta = -40°C to +80°C.  | N                             |
| CSA FISCO field device intrinsically safe for Class I, Division 1, Groups A, B, C, and D; Class II, Division 1, Groups E, F, and G; Class III, Division 1.<br><br>Also zone certified intrinsically safe Ex ia IIC, and energy limited Ex nA II. | Temperature Class T6 at 40°C and T4A at 85°C maximum ambient.<br><br>Temperature Class T4 at 40°C and T3 at 85°C maximum ambient. | C                             |
| CSA explosionproof for Class I, Division 1, Groups B, C, and D; and dust-ignitionproof for Class II, Division 1, Groups E, F, and G; and Class III, Division 1.  | Maximum Ambient Temperature 85°C.   | C                             |
| CSA FNICO field device Class I, Division 2, Groups A, B, C, and D; Class II, Division 2, Groups F and G; and Class III, Division 2.  | Temperature Class T6 at 40°C and T4A at 85°C maximum ambient.   | C                             |
| CSA field device zone certified flameproof, Ex d IIC. Also, all certifications of Code C above.  | Maximum Ambient Temperature 85°C.   | B                             |
| FM FISCO field device intrinsically safe for Class I, Division 1, Groups A, B, C, and D; Class II, Division 1, Groups E, F, and G; Class III, Division 1.<br><br>Also zone approved intrinsically safe AEx ia IIC.                               | Temperature Class T4A at 40°C and T4 at 85°C maximum ambient.<br><br>Temperature Class T4 at 85°C maximum ambient.                | F                             |
| FM explosionproof for Class I, Division 1, Groups B, C, & D; and dust-ignitionproof for Class II, Division 1, Groups E, F, and G; and Class III, Division 1.   | Temperature Class T6 at 80°C and T5 at 85°C maximum ambient.  | F                             |
| FM FNICO field device nonincendive Class I, Division 2, Groups A, B, C, and D; Class II, Division 2, Groups F and G; and Class III, Division 2.  | Temperature Class T4A at 40°C and T4 at 85°C maximum ambient.   | F                             |
| FM field device zone approved flameproof, AEx d IIC. Also, all certifications of Code F above.   | Temperature Class T6 at 75°C maximum ambient.   | G                             |
| IECEX FISCO field device intrinsically safe, Ex ia IIC, Zone 0.  | Temperature Class T4, Ta = -40°C to +80°C.  | T                             |
| IECEX flameproof, Ex d IIC.  | T6, Ta = 80°C; T5, Ta = 85°C<br>Ambient Temperature -20°C to +85°C.   | V                             |
| IECEX FNICO field device protection n, Ex nL IIC, Zone 2.  | Temperature Class T4, Ta = -40°C to +80°C.  | U                             |

**ELECTRICAL SAFETY SPECIFICATIONS – IDP10 TRANSMITTERS**

Transmitters have been designed to meet the Electrical Specifications listed in the tables that follow. Contact Global Customer Support for information or status of testing lab approvals or certifications.

See “MODEL CODE: IDP10 TRANSMITTER” on page 32 for availability of Electrical Safety Design Codes with Transmitter Structure Codes.

| Testing Laboratory, Types of Protection, and Area Classification   | Application Conditions  | Electrical Safety Design Code |
|--|---|-------------------------------|
| ATEX flameproof; II 2 GD, EEx d IIC, Zone 1.   | Temperature Class T6, T85°C, Ta = -40°C to +80°C.   | D                             |
| ATEX FISCO field device intrinsically safe; II 1 G, EEx ia IIC, Zone 0.  | Temperature Class T4, Ta = -40°C to +80°C.  | E                             |
| ATEX FNICO field device protection n; II 3 G, EEx nL IIC, Zone 2.  | Temperature Class T4, Ta = -40°C to +80°C.  | N                             |
| CSA FISCO field device intrinsically safe for Class I, Division 1, Groups A, B, C, and D; Class II, Division 1, Groups E, F, and G; Class III, Division 1.<br><br>Also zone certified intrinsically safe Ex ia IIC, and energy limited Ex nA II. | Temperature Class T6 at 40°C and T4A at 85°C maximum ambient.<br><br>Temperature Class T4 at 40°C and T3 at 85°C maximum ambient. | C                             |
| CSA explosionproof for Class I, Division 1, Groups B, C, and D; and dust-ignitionproof for Class II, Division 1, Groups E, F, and G; and Class III, Division 1.  | Maximum Ambient Temperature 85°C.   | C                             |
| CSA FNICO field device Class I, Division 2, Groups A, B, C, and D; Class II, Division 2, Groups F and G; and Class III, Division 2.  | Temperature Class T6 at 40°C and T4A at 85°C maximum ambient.   | C                             |
| CSA field device zone certified flameproof, Ex d IIC. Also, all certifications of Code C above.  | Maximum Ambient Temperature 85°C.   | B                             |
| FM FISCO field device intrinsically safe for Class I, Division 1, Groups A, B, C, and D; Class II, Division 1, Groups E, F, and G; Class III, Division 1.<br><br>Also zone approved intrinsically safe AEx ia IIC.                               | Temperature Class T4A at 40°C and T4 at 85°C maximum ambient.<br><br>Temperature Class T4 at 85°C maximum ambient.                | F                             |
| FM explosionproof for Class I, Division 1, Groups B, C, & D; and dust-ignitionproof for Class II, Division 1, Groups E, F, and G; and Class III, Division 1.   | Temperature Class T6 at 80°C and T5 at 85°C maximum ambient.  | F                             |
| FM FNICO field device nonincendive Class I, Division 2, Groups A, B, C, and D; Class II, Division 2, Groups F and G; and Class III, Division 2.  | Temperature Class T4A at 40°C and T4 at 85°C maximum ambient.   | F                             |
| FM field device zone approved flameproof, AEx d IIC. Also, all certifications of Code F above.   | Temperature Class T6 at 75°C maximum ambient.   | G                             |
| IECEx FISCO field device intrinsically safe, Ex ia IIC, Zone 0.  | Temperature Class T4, Ta = -40°C to +80°C.  | T                             |
| IECEx flameproof, Ex d IIC.  | T6, Ta = 80°C; T5, Ta= 85°C<br>Ambient Temperature -20°C to +85°C.  | V                             |
| IECEx FNICO field device protection n, Ex nL IIC, Zone 2.  | Temperature Class T4, Ta = -40°C to +80°C.  | U                             |

## IAP10 AND IGP10 DIRECT-CONNECTED TRANSMITTERS

### Exceptional Value

The combination of small size, light weight, direct mounting, standard materials, and wide measurement capability with high performance make this an exceptionally cost effective solution for process pressure measurement.

### Direct Process Mounting

Because of their light weight and external threaded connection, these transmitters can be installed directly on process piping without mounting brackets. However, for unique requirements, an optional bracket is offered and connection can be made to the standard 1/4 NPT internal thread.

### Wide Rangeability

Three absolute pressure versions are offered to allow spans from 7 to 21,000 kPa (1 to 3,000 psi), and four gauge pressure versions are offered to allow spans from 7 to 42,000 kPa (1 to 6,000 psi). Refer to IGP20 Transmitter for gauge pressure vacuum service.

### 316L ss, Nickel Alloy, and Co-Ni-Cr Process Wetted Parts

With process connection of 316L ss or nickel alloy<sup>(1)</sup>, and sensor diaphragm available in either 316L ss, nickel alloy, or highly corrosion resistant Co-Ni-Cr, this transmitter is an excellent choice for the vast majority of process pressure measurements.

### Span and Range Limits for IAP10 and IGP10 Transmitters

| Span Limit Code | Span Limits    |               |              | Range Limits (Absolute or Gauge Units) |            |           |
|-----------------|----------------|---------------|--------------|--|------------|-----------|
|                 | MPa            | psi           | bar          | MPa                                    | psi        | bar       |
| C               | 0.007 and 0.21 | 1 and 30      | 0.07 and 2.1 | 0 and 0.21                             | 0 and 30   | 0 and 2.1 |
| D               | 0.07 and 2.1   | 10 and 300    | 0.7 and 21   | 0 and 2.1                              | 0 and 300  | 0 and 21  |
| E               | 0.7 and 21     | 100 and 3000  | 7 and 210    | 0 and 21                               | 0 and 3000 | 0 and 210 |
| F (a)           | 14 and 42      | 2000 and 6000 | 140 and 420  | 0 and 42                               | 0 and 6000 | 0 and 420 |

a. Span Limit Code F is applicable to IGP10 Transmitter only.

Figure 7. Direct-Connected Transmitter  
(Flameproof Version on Left)



### High Gauge Pressure Versions

Three high gauge pressure versions with upper range limits of 52, 105, and 210 MPa (7500, 15,000, and 30,000 psi) are available in the IGP10 line. Refer to PSS 2A-1C13 F for detailed specifications.

### Sanitary and Pulp and Paper Versions

These transmitters are also available with integral process connections for use in sanitary and pulp and paper installations. See PSS 2A-1C13 K and PSS 2A-1C13 L, respectively.

### Flameproof Design

These transmitters are designed to meet Agency flameproof and zone requirements.

1. Equivalent to Hastelloy®. Hastelloy is a registered trademark of Haynes International, Inc.

**Maximum Overage and Proof Pressure Ratings for IAP10 and IGP10 Transmitters**

| Span Limit Code | Maximum Overage Pressure Rating (a) |      |      | Proof Pressure Rating (a) (b) |       |      |
|-----------------|-------------------------------------|------|------|-------------------------------|-------|------|
|                 | MPa                                 | psi  | bar  | MPa                           | psi   | bar  |
| C               | 0.31                                | 45   | 3.15 | 0.827                         | 120   | 8.27 |
| D               | 3.1                                 | 450  | 31.5 | 8.27                          | 1200  | 82.7 |
| E               | 31                                  | 4500 | 315  | 79.3                          | 11500 | 793  |
| F (c)           | 58                                  | 8400 | 580  | 152                           | 22000 | 1517 |

- a. Values listed are in absolute or gauge pressure units, as applicable. Maximum overrange pressure is the maximum pressure that may be applied without causing damage to the transmitter.
- b. Proof pressure ratings meet ANSI/ISA Standard S82.03-1988. Unit may become nonfunctional after application of proof pressure.
- c. Span Limit Code F is applicable to IGP10 Transmitter only. Also not available if pressure seals are selected.

**Accuracy; Includes Linearity, Hysteresis, and Repeatability**

| Accuracy, % of Span (a) |                               |
|-------------------------|-------------------------------|
| Spans ≥10% URL          | Spans <10% URL                |
| ±0.050%                 | ±[0.015 + 0.0035 (URL/Span)]% |

- a. Add ±0.04% for Span Code A, and ±0.02% for Span Codes E and F.

**NOTE**

Accuracy is at Reference Operating Conditions; Zero-based Calibrations; Co-Ni-Cr or 316L ss sensor with silicone fluid; URL = upper range limit; and span = calibrated span.

**Stability (Long Term Drift)**

< ±0.05% of URL per year over a 5-year period.

**Calibration Frequency**

The calibration frequency is five years. The five years is derived using the values of allowable error (% span), TPE (% span), performance margin (% span), and stability (% span/month); where:

$$\text{Calibration Frequency} = \frac{\text{Performance Margin}}{\text{Stability}} = \text{Months}$$

**Process Wetted Materials**

**Process Connection**

316L ss or nickel alloy<sup>(2)</sup>

**Sensor Diaphragm**

Co-Ni-Cr, 316L ss, or nickel alloy<sup>(2)</sup>

**Pressure Seal Diaphragm Material**

Varies with pressure seal selected. See PSS 2A-1Z11 A.

**Fill Fluid**

Silicone Oil or Inert FC43, as specified.

**Reference (Atmospheric Pressure) Side Materials**

**IAP10**

Not applicable

**IGP10 with Span Codes C and D**

Silicon, Pyrex, RTV, and 316 ss

**IGP10 with Span Codes E and F**

Not applicable

2. Equivalent to Hastelloy® C.



**Vibration Effect**

Total effect is  $\pm 0.2\%$  of URL per “g” for vibrations in the frequency range of 5 to 500 Hz; with double amplitudes of 6.3 mm (0.25 in) in the range of 5 to 15 Hz, or accelerations of 3 “g” in the range of 15 to 500 Hz, whichever is smaller, for transmitters with aluminum housings; and with double amplitudes of 6.3 mm (0.25 in) in the range of 5 to 9 Hz, or accelerations of 1 “g” in the range of 9 to 500 Hz, whichever is smaller, for transmitters with 316 ss housings.

**Ambient Temperature Effect**

Total effect for a 28°C (50°F) change within Normal Operating Condition limits is:

| Span Code          | Ambient Temperature Effect                      |
|--------------------|---|
| C, D, E, and F (a) | $\pm(0.03\% \text{ URL} + 0.06\% \text{ Span})$ |

a. Span Code F applicable to IGP10 Transmitter only.

**NOTE**

For additional ambient temperature effect when pressure seals are used, see PSS 2A-1Z11 A.

**Approximate Mass**

- ▶ With aluminum housing: 1.5 kg (3.3 lb)
- ▶ With 316 ss Housing: Add 1.1 kg (2.4 lb)
- ▶ With LCD Indicator Option: Add 0.2 kg (0.4 lb)
- ▶ With Pressure Seals: See PSS 2A-1Z11 A

**Accessories**

IAP10 and IGP10 Transmitters can be provided with integral connections for both sanitary, and pulp and paper processes. With these applications, numerous accessories are offered, including tank spuds, weld spuds, heat sinks/plugs, calibration adapters, Tri-clamps, and O-rings (or gaskets). Refer to PSS 2A-1C13 K (Sanitary Processes) and PSS 2A-1C13 L (Pulp and Paper Processes) for complete specifications.

**MODEL CODE: IAP10 AND IGP10 TRANSMITTERS**

| Description   | Model            |        |            |  |                 |  |         |          |  |          |  |    |         |          |  |       |  |    |         |                  |  |          |  |    |         |                  |  |       |  |    |                  |                  |  |          |  |    |                  |                  |  |       |  |    |  |
|---|------------------|--------|------------|--|-----------------|--|---------|----------|--|----------|--|----|---------|----------|--|-------|--|----|---------|------------------|--|----------|--|----|---------|------------------|--|-------|--|----|------------------|------------------|--|----------|--|----|------------------|------------------|--|-------|--|----|--|
| I/A Series, Electronic, Direct Connected Absolute Pressure Transmitter  | IAP10 (a)        |        |            |  |                 |  |         |          |  |          |  |    |         |          |  |       |  |    |         |                  |  |          |  |    |         |                  |  |       |  |    |                  |                  |  |          |  |    |                  |                  |  |       |  |    |  |
| I/A Series, Electronic, Direct Connected Gauge Pressure Transmitter   | IGP10 (a)        |        |            |  |                 |  |         |          |  |          |  |    |         |          |  |       |  |    |         |                  |  |          |  |    |         |                  |  |       |  |    |                  |                  |  |          |  |    |                  |                  |  |       |  |    |  |
| <b>Electronics Versions and Output Signal</b>   |                  |        |            |  |                 |  |         |          |  |          |  |    |         |          |  |       |  |    |         |                  |  |          |  |    |         |                  |  |       |  |    |                  |                  |  |          |  |    |                  |                  |  |       |  |    |  |
| Intelligent; Digital FOUNDATION Fieldbus (Version –F)   | –F               |        |            |  |                 |  |         |          |  |          |  |    |         |          |  |       |  |    |         |                  |  |          |  |    |         |                  |  |       |  |    |                  |                  |  |          |  |    |                  |                  |  |       |  |    |  |
| <b>Structure Code - Select from one of the following six groups:</b>  |                  |        |            |  |                 |  |         |          |  |          |  |    |         |          |  |       |  |    |         |                  |  |          |  |    |         |                  |  |       |  |    |                  |                  |  |          |  |    |                  |                  |  |       |  |    |  |
| <b>1. Transmitter Only (no seals)</b>   |                  |        |            |  |                 |  |         |          |  |          |  |    |         |          |  |       |  |    |         |                  |  |          |  |    |         |                  |  |       |  |    |                  |                  |  |          |  |    |                  |                  |  |       |  |    |  |
| <table border="0"> <thead> <tr> <th>Process</th> <th>Sensor</th> <th>Sensor</th> <th>Fill Fluid</th> <th>Connection Type</th> <th></th> </tr> </thead> <tbody> <tr> <td>316L ss</td> <td>Co-Ni-Cr</td> <td></td> <td>Silicone</td> <td>1/2 NPT External Thread, 1/4 NPT Internal Thread</td> <td>20</td> </tr> <tr> <td>316L ss</td> <td>Co-Ni-Cr</td> <td></td> <td>Inert</td> <td>1/2 NPT External Thread, 1/4 NPT Internal Thread</td> <td>21</td> </tr> <tr> <td>316L ss</td> <td>316L ss</td> <td></td> <td>Silicone</td> <td>1/2 NPT External Thread, 1/4 NPT Internal Thread</td> <td>22</td> </tr> <tr> <td>316L ss</td> <td>316L ss</td> <td></td> <td>Inert</td> <td>1/2 NPT External Thread, 1/4 NPT Internal Thread</td> <td>23</td> </tr> <tr> <td>316L ss</td> <td>Nickel alloy (b)</td> <td></td> <td>Silicone</td> <td>1/2 NPT External Thread, 1/4 NPT Internal Thread</td> <td>30</td> </tr> <tr> <td>316L ss</td> <td>Nickel alloy (b)</td> <td></td> <td>Inert</td> <td>1/2 NPT External Thread, 1/4 NPT Internal Thread</td> <td>31</td> </tr> </tbody> </table>           | Process          | Sensor | Sensor     | Fill Fluid                                       | Connection Type |  | 316L ss | Co-Ni-Cr |  | Silicone | 1/2 NPT External Thread, 1/4 NPT Internal Thread | 20 | 316L ss | Co-Ni-Cr |  | Inert | 1/2 NPT External Thread, 1/4 NPT Internal Thread | 21 | 316L ss | 316L ss          |  | Silicone | 1/2 NPT External Thread, 1/4 NPT Internal Thread | 22 | 316L ss | 316L ss          |  | Inert | 1/2 NPT External Thread, 1/4 NPT Internal Thread | 23 | 316L ss          | Nickel alloy (b) |  | Silicone | 1/2 NPT External Thread, 1/4 NPT Internal Thread | 30 | 316L ss          | Nickel alloy (b) |  | Inert | 1/2 NPT External Thread, 1/4 NPT Internal Thread | 31 |  |
| Process   | Sensor           | Sensor | Fill Fluid | Connection Type                                  |                 |  |         |          |  |          |  |    |         |          |  |       |  |    |         |                  |  |          |  |    |         |                  |  |       |  |    |                  |                  |  |          |  |    |                  |                  |  |       |  |    |  |
| 316L ss   | Co-Ni-Cr         |        | Silicone   | 1/2 NPT External Thread, 1/4 NPT Internal Thread | 20              |  |         |          |  |          |  |    |         |          |  |       |  |    |         |                  |  |          |  |    |         |                  |  |       |  |    |                  |                  |  |          |  |    |                  |                  |  |       |  |    |  |
| 316L ss   | Co-Ni-Cr         |        | Inert      | 1/2 NPT External Thread, 1/4 NPT Internal Thread | 21              |  |         |          |  |          |  |    |         |          |  |       |  |    |         |                  |  |          |  |    |         |                  |  |       |  |    |                  |                  |  |          |  |    |                  |                  |  |       |  |    |  |
| 316L ss   | 316L ss          |        | Silicone   | 1/2 NPT External Thread, 1/4 NPT Internal Thread | 22              |  |         |          |  |          |  |    |         |          |  |       |  |    |         |                  |  |          |  |    |         |                  |  |       |  |    |                  |                  |  |          |  |    |                  |                  |  |       |  |    |  |
| 316L ss   | 316L ss          |        | Inert      | 1/2 NPT External Thread, 1/4 NPT Internal Thread | 23              |  |         |          |  |          |  |    |         |          |  |       |  |    |         |                  |  |          |  |    |         |                  |  |       |  |    |                  |                  |  |          |  |    |                  |                  |  |       |  |    |  |
| 316L ss   | Nickel alloy (b) |        | Silicone   | 1/2 NPT External Thread, 1/4 NPT Internal Thread | 30              |  |         |          |  |          |  |    |         |          |  |       |  |    |         |                  |  |          |  |    |         |                  |  |       |  |    |                  |                  |  |          |  |    |                  |                  |  |       |  |    |  |
| 316L ss   | Nickel alloy (b) |        | Inert      | 1/2 NPT External Thread, 1/4 NPT Internal Thread | 31              |  |         |          |  |          |  |    |         |          |  |       |  |    |         |                  |  |          |  |    |         |                  |  |       |  |    |                  |                  |  |          |  |    |                  |                  |  |       |  |    |  |
| <b>2. Transmitter Prepared for Foxboro Model Coded Seals (c)</b>  |                  |        |            |  |                 |  |         |          |  |          |  |    |         |          |  |       |  |    |         |                  |  |          |  |    |         |                  |  |       |  |    |                  |                  |  |          |  |    |                  |                  |  |       |  |    |  |
| Transmitter Prepared for Foxboro Direct Connect Seal; Silicone Fill in Sensor (d)   | D1               |        |            |  |                 |  |         |          |  |          |  |    |         |          |  |       |  |    |         |                  |  |          |  |    |         |                  |  |       |  |    |                  |                  |  |          |  |    |                  |                  |  |       |  |    |  |
| Transmitter Prepared for Foxboro Direct Connect Seal; Inert Fill in Sensor (IGP10 only) (d)   | D2               |        |            |  |                 |  |         |          |  |          |  |    |         |          |  |       |  |    |         |                  |  |          |  |    |         |                  |  |       |  |    |                  |                  |  |          |  |    |                  |                  |  |       |  |    |  |
| Transmitter Prepared for Foxboro Remote Mount Seal; Silicone Fill in Sensor (e)   | S3               |        |            |  |                 |  |         |          |  |          |  |    |         |          |  |       |  |    |         |                  |  |          |  |    |         |                  |  |       |  |    |                  |                  |  |          |  |    |                  |                  |  |       |  |    |  |
| Transmitter Prepared for Foxboro Remote Mount Seal; Inert Fill in Sensor (IGP10 only) (e)   | S4               |        |            |  |                 |  |         |          |  |          |  |    |         |          |  |       |  |    |         |                  |  |          |  |    |         |                  |  |       |  |    |                  |                  |  |          |  |    |                  |                  |  |       |  |    |  |
| <b>3. Transmitters Prepared for non-Foxboro Seals</b>   |                  |        |            |  |                 |  |         |          |  |          |  |    |         |          |  |       |  |    |         |                  |  |          |  |    |         |                  |  |       |  |    |                  |                  |  |          |  |    |                  |                  |  |       |  |    |  |
| Transmitter Prepared for Remote Seal; Silicone Fill in Sensor (f)   | SC               |        |            |  |                 |  |         |          |  |          |  |    |         |          |  |       |  |    |         |                  |  |          |  |    |         |                  |  |       |  |    |                  |                  |  |          |  |    |                  |                  |  |       |  |    |  |
| Transmitter Prepared for Remote Seal; Inert Fill in Sensor (g)  | SD               |        |            |  |                 |  |         |          |  |          |  |    |         |          |  |       |  |    |         |                  |  |          |  |    |         |                  |  |       |  |    |                  |                  |  |          |  |    |                  |                  |  |       |  |    |  |
| <b>4. Flameproof Transmitter Only (no seals)</b>  |                  |        |            |  |                 |  |         |          |  |          |  |    |         |          |  |       |  |    |         |                  |  |          |  |    |         |                  |  |       |  |    |                  |                  |  |          |  |    |                  |                  |  |       |  |    |  |
| <table border="0"> <thead> <tr> <th>Process</th> <th>Sensor</th> <th>Sensor</th> <th>Fill Fluid</th> <th>Connection Type</th> <th></th> </tr> </thead> <tbody> <tr> <td>316L ss</td> <td>316L ss</td> <td></td> <td>Silicone</td> <td>1/2 NPT External and 1/4 NPT Internal Thread</td> <td>52</td> </tr> <tr> <td>316L ss</td> <td>316L ss</td> <td></td> <td>Inert</td> <td>1/2 NPT External and 1/4 NPT Internal Thread</td> <td>53</td> </tr> <tr> <td>316L ss</td> <td>Nickel alloy (b)</td> <td></td> <td>Silicone</td> <td>1/2 NPT External and 1/4 NPT Internal Thread</td> <td>61</td> </tr> <tr> <td>316L ss</td> <td>Nickel alloy (b)</td> <td></td> <td>Inert</td> <td>1/2 NPT External and 1/4 NPT Internal Thread</td> <td>62</td> </tr> <tr> <td>Nickel alloy (b)</td> <td>Nickel alloy (b)</td> <td></td> <td>Silicone</td> <td>1/2 NPT External and 1/4 NPT Internal Thread</td> <td>63</td> </tr> <tr> <td>Nickel alloy (b)</td> <td>Nickel alloy (b)</td> <td></td> <td>Inert</td> <td>1/2 NPT External and 1/4 NPT Internal Thread</td> <td>64</td> </tr> </tbody> </table> | Process          | Sensor | Sensor     | Fill Fluid                                       | Connection Type |  | 316L ss | 316L ss  |  | Silicone | 1/2 NPT External and 1/4 NPT Internal Thread     | 52 | 316L ss | 316L ss  |  | Inert | 1/2 NPT External and 1/4 NPT Internal Thread     | 53 | 316L ss | Nickel alloy (b) |  | Silicone | 1/2 NPT External and 1/4 NPT Internal Thread     | 61 | 316L ss | Nickel alloy (b) |  | Inert | 1/2 NPT External and 1/4 NPT Internal Thread     | 62 | Nickel alloy (b) | Nickel alloy (b) |  | Silicone | 1/2 NPT External and 1/4 NPT Internal Thread     | 63 | Nickel alloy (b) | Nickel alloy (b) |  | Inert | 1/2 NPT External and 1/4 NPT Internal Thread     | 64 |  |
| Process   | Sensor           | Sensor | Fill Fluid | Connection Type                                  |                 |  |         |          |  |          |  |    |         |          |  |       |  |    |         |                  |  |          |  |    |         |                  |  |       |  |    |                  |                  |  |          |  |    |                  |                  |  |       |  |    |  |
| 316L ss   | 316L ss          |        | Silicone   | 1/2 NPT External and 1/4 NPT Internal Thread     | 52              |  |         |          |  |          |  |    |         |          |  |       |  |    |         |                  |  |          |  |    |         |                  |  |       |  |    |                  |                  |  |          |  |    |                  |                  |  |       |  |    |  |
| 316L ss   | 316L ss          |        | Inert      | 1/2 NPT External and 1/4 NPT Internal Thread     | 53              |  |         |          |  |          |  |    |         |          |  |       |  |    |         |                  |  |          |  |    |         |                  |  |       |  |    |                  |                  |  |          |  |    |                  |                  |  |       |  |    |  |
| 316L ss   | Nickel alloy (b) |        | Silicone   | 1/2 NPT External and 1/4 NPT Internal Thread     | 61              |  |         |          |  |          |  |    |         |          |  |       |  |    |         |                  |  |          |  |    |         |                  |  |       |  |    |                  |                  |  |          |  |    |                  |                  |  |       |  |    |  |
| 316L ss   | Nickel alloy (b) |        | Inert      | 1/2 NPT External and 1/4 NPT Internal Thread     | 62              |  |         |          |  |          |  |    |         |          |  |       |  |    |         |                  |  |          |  |    |         |                  |  |       |  |    |                  |                  |  |          |  |    |                  |                  |  |       |  |    |  |
| Nickel alloy (b)  | Nickel alloy (b) |        | Silicone   | 1/2 NPT External and 1/4 NPT Internal Thread     | 63              |  |         |          |  |          |  |    |         |          |  |       |  |    |         |                  |  |          |  |    |         |                  |  |       |  |    |                  |                  |  |          |  |    |                  |                  |  |       |  |    |  |
| Nickel alloy (b)  | Nickel alloy (b) |        | Inert      | 1/2 NPT External and 1/4 NPT Internal Thread     | 64              |  |         |          |  |          |  |    |         |          |  |       |  |    |         |                  |  |          |  |    |         |                  |  |       |  |    |                  |                  |  |          |  |    |                  |                  |  |       |  |    |  |
| <b>5. Flameproof Transmitter Prepared for Foxboro Model Coded Seals (c)</b>   |                  |        |            |  |                 |  |         |          |  |          |  |    |         |          |  |       |  |    |         |                  |  |          |  |    |         |                  |  |       |  |    |                  |                  |  |          |  |    |                  |                  |  |       |  |    |  |
| Flameproof Transmitter Prepared for Direct Connect Seal; Silicone Fill in Sensor (d)  | D5               |        |            |  |                 |  |         |          |  |          |  |    |         |          |  |       |  |    |         |                  |  |          |  |    |         |                  |  |       |  |    |                  |                  |  |          |  |    |                  |                  |  |       |  |    |  |
| Flameproof Transmitter Prepared for Direct Connect Seal; Inert Fill in Sensor (IGP10 only) (d)  | D6               |        |            |  |                 |  |         |          |  |          |  |    |         |          |  |       |  |    |         |                  |  |          |  |    |         |                  |  |       |  |    |                  |                  |  |          |  |    |                  |                  |  |       |  |    |  |
| Flameproof Transmitter Prepared for Remote Mount Seal; Silicone Fill in Sensor (e)  | S5               |        |            |  |                 |  |         |          |  |          |  |    |         |          |  |       |  |    |         |                  |  |          |  |    |         |                  |  |       |  |    |                  |                  |  |          |  |    |                  |                  |  |       |  |    |  |
| Flameproof Transmitter Prepared for Remote Mount Seal; Inert Fill in Sensor (IGP10 only) (e)  | S6               |        |            |  |                 |  |         |          |  |          |  |    |         |          |  |       |  |    |         |                  |  |          |  |    |         |                  |  |       |  |    |                  |                  |  |          |  |    |                  |                  |  |       |  |    |  |
| <b>6. Flameproof Transmitter Prepared for non-Foxboro Seals</b>   |                  |        |            |  |                 |  |         |          |  |          |  |    |         |          |  |       |  |    |         |                  |  |          |  |    |         |                  |  |       |  |    |                  |                  |  |          |  |    |                  |                  |  |       |  |    |  |
| Flameproof Transmitter Prepared for Remote Seal; Silicone Fill in Sensor (f)  | SH               |        |            |  |                 |  |         |          |  |          |  |    |         |          |  |       |  |    |         |                  |  |          |  |    |         |                  |  |       |  |    |                  |                  |  |          |  |    |                  |                  |  |       |  |    |  |
| Flameproof Transmitter Prepared for Remote Seal; Inert Fill in Sensor (g)   | SJ               |        |            |  |                 |  |         |          |  |          |  |    |         |          |  |       |  |    |         |                  |  |          |  |    |         |                  |  |       |  |    |                  |                  |  |          |  |    |                  |                  |  |       |  |    |  |

**MODEL CODE: IAP10 AND IGP10 TRANSMITTERS (CONTINUED)**

| Description   | Model         |                          |            |  |                |          |              |   |              |            |            |   |            |              |           |   |           |               |                          |   |  |
|---|---------------|--------------------------|------------|--|----------------|----------|--------------|---|--------------|------------|------------|---|------------|--------------|-----------|---|-----------|---------------|--------------------------|---|--|
| <b>Span Limits - Absolute or Gauge Pressure Units, as Applicable</b>  |               |                          |            |  |                |          |              |   |              |            |            |   |            |              |           |   |           |               |                          |   |  |
| <table border="0"> <tr> <td><b>MPa</b></td> <td><b>psi</b></td> <td><b>bar</b></td> <td></td> </tr> <tr> <td>0.007 and 0.21</td> <td>1 and 30</td> <td>0.07 and 2.1</td> <td>C</td> </tr> <tr> <td>0.07 and 2.1</td> <td>10 and 300</td> <td>0.7 and 21</td> <td>D</td> </tr> <tr> <td>0.7 and 21</td> <td>100 and 3000</td> <td>7 and 210</td> <td>E</td> </tr> <tr> <td>14 and 42</td> <td>2000 and 6000</td> <td>140 and 420 (IGP10 only)</td> <td>F</td> </tr> </table> | <b>MPa</b>    | <b>psi</b>               | <b>bar</b> |  | 0.007 and 0.21 | 1 and 30 | 0.07 and 2.1 | C | 0.07 and 2.1 | 10 and 300 | 0.7 and 21 | D | 0.7 and 21 | 100 and 3000 | 7 and 210 | E | 14 and 42 | 2000 and 6000 | 140 and 420 (IGP10 only) | F |  |
| <b>MPa</b>  | <b>psi</b>    | <b>bar</b>               |            |  |                |          |              |   |              |            |            |   |            |              |           |   |           |               |                          |   |  |
| 0.007 and 0.21  | 1 and 30      | 0.07 and 2.1             | C          |  |                |          |              |   |              |            |            |   |            |              |           |   |           |               |                          |   |  |
| 0.07 and 2.1  | 10 and 300    | 0.7 and 21               | D          |  |                |          |              |   |              |            |            |   |            |              |           |   |           |               |                          |   |  |
| 0.7 and 21  | 100 and 3000  | 7 and 210                | E          |  |                |          |              |   |              |            |            |   |            |              |           |   |           |               |                          |   |  |
| 14 and 42   | 2000 and 6000 | 140 and 420 (IGP10 only) | F          |  |                |          |              |   |              |            |            |   |            |              |           |   |           |               |                          |   |  |
| <b>Conduit Connection and Housing Material</b>  |               |                          |            |  |                |          |              |   |              |            |            |   |            |              |           |   |           |               |                          |   |  |
| 1/2 NPT Conduit Connection, Aluminum Housing  | 1             |                          |            |  |                |          |              |   |              |            |            |   |            |              |           |   |           |               |                          |   |  |
| PG 13.5 Conduit Connection, Aluminum Housing (With Electrical Safety Code D only)   | 2             |                          |            |  |                |          |              |   |              |            |            |   |            |              |           |   |           |               |                          |   |  |
| 1/2 NPT Conduit Connection, 316 ss Housing  | 3             |                          |            |  |                |          |              |   |              |            |            |   |            |              |           |   |           |               |                          |   |  |
| PG 13.5 Conduit Connection, 316 ss Housing (With Electrical Safety Code D only)   | 4             |                          |            |  |                |          |              |   |              |            |            |   |            |              |           |   |           |               |                          |   |  |
| M20 Conduit Connection, Both Sides, Aluminum Housing (With Electrical Safety Code D only)   | 5             |                          |            |  |                |          |              |   |              |            |            |   |            |              |           |   |           |               |                          |   |  |
| M20 Conduit Connection, Both Sides, 316 ss Housing (With Electrical Safety Code D only)   | 6             |                          |            |  |                |          |              |   |              |            |            |   |            |              |           |   |           |               |                          |   |  |
| <b>Electrical Safety (See "ELECTRICAL SAFETY SPECIFICATIONS – IAP10 AND IGP10 TRANSMITTERS" on page 11 for Description and Approval Status)</b>   |               |                          |            |  |                |          |              |   |              |            |            |   |            |              |           |   |           |               |                          |   |  |
| ATEX Flameproof; II 2 GD, EEx d IIC, Zone 1 (h) (i)   | D             |                          |            |  |                |          |              |   |              |            |            |   |            |              |           |   |           |               |                          |   |  |
| ATEX FISCO Intrinsically Safe; II 1 G, EEx ia IIC, Zone 0   | E             |                          |            |  |                |          |              |   |              |            |            |   |            |              |           |   |           |               |                          |   |  |
| ATEX FNICO protection n; II 3 G, Ex nL IIC, Zone 2  | N             |                          |            |  |                |          |              |   |              |            |            |   |            |              |           |   |           |               |                          |   |  |
| CSA Certifications: (j)<br>Division 1 explosionproof and dust-ignitionproof<br>FISCO Division 1, Classes I, II, and III<br>FISCO Zone certified Ex ia IIC, and energy limited Ex nA II<br>FNICO Division 2, Classes I, II, and III  | C             |                          |            |  |                |          |              |   |              |            |            |   |            |              |           |   |           |               |                          |   |  |
| CSA zone certified flameproof, Ex d IIC; also all certifications of Code C above (h) (i)  | B             |                          |            |  |                |          |              |   |              |            |            |   |            |              |           |   |           |               |                          |   |  |
| FM Approvals: (j)<br>Division 1 explosionproof and dust-ignitionproof<br>FISCO Division 1, Classes I, II, and III<br>FISCO Zone approved Ex ia IIC<br>FNICO nonincendive Division 2, Classes I, II, and III   | F             |                          |            |  |                |          |              |   |              |            |            |   |            |              |           |   |           |               |                          |   |  |
| FM approved flameproof, AEx d IIC; also all approvals of Code F above (h) (i)   | G             |                          |            |  |                |          |              |   |              |            |            |   |            |              |           |   |           |               |                          |   |  |
| IECEX FISCO intrinsically safe, Ex ia IIC, Zone 0   | T             |                          |            |  |                |          |              |   |              |            |            |   |            |              |           |   |           |               |                          |   |  |
| IECEX flameproof; Ex d IIC, Zone 1 (h) (i)  | V             |                          |            |  |                |          |              |   |              |            |            |   |            |              |           |   |           |               |                          |   |  |
| IECEX FNICO protection n; Ex nL IIC, Zone 2   | U             |                          |            |  |                |          |              |   |              |            |            |   |            |              |           |   |           |               |                          |   |  |
| <b>Optional Selections</b>  |               |                          |            |  |                |          |              |   |              |            |            |   |            |              |           |   |           |               |                          |   |  |
| <b>Mounting Bracket Set (k)</b>   |               |                          |            |  |                |          |              |   |              |            |            |   |            |              |           |   |           |               |                          |   |  |
| Painted Steel Bracket with Plated Steel Bolts, 1/2 NPT (with Conduit Connection Codes 1 and 3 only)   | -M1           |                          |            |  |                |          |              |   |              |            |            |   |            |              |           |   |           |               |                          |   |  |
| Stainless Steel Bracket with Stainless Steel Bolts, 1/2 NPT (with Conduit Connection Codes 1 and 3 only)  | -M2           |                          |            |  |                |          |              |   |              |            |            |   |            |              |           |   |           |               |                          |   |  |
| Painted Steel Bracket with Plated Steel Bolts, PG 13.5 (with Conduit Connection Codes 2 and 4 only)   | -M3           |                          |            |  |                |          |              |   |              |            |            |   |            |              |           |   |           |               |                          |   |  |
| Stainless Steel Bracket with Stainless Steel Bolts, PG 13.5 (with Conduit Connection Codes 2 and 4 only)  | -M4           |                          |            |  |                |          |              |   |              |            |            |   |            |              |           |   |           |               |                          |   |  |
| Painted Steel Bracket with Plated Steel Bolts, M20 (with Conduit Connection Codes 5 and 6 only)   | -M5           |                          |            |  |                |          |              |   |              |            |            |   |            |              |           |   |           |               |                          |   |  |
| Stainless Steel Bracket with Stainless Steel Bolts, M20 (with Conduit Connection Codes 5 and 6 only)  | -M6           |                          |            |  |                |          |              |   |              |            |            |   |            |              |           |   |           |               |                          |   |  |
| <b>Digital Indicator with Pushbuttons</b>   |               |                          |            |  |                |          |              |   |              |            |            |   |            |              |           |   |           |               |                          |   |  |
| Digital Indicator, Pushbuttons, and Window Cover  | -L1           |                          |            |  |                |          |              |   |              |            |            |   |            |              |           |   |           |               |                          |   |  |

**MODEL CODE: IAP10 AND IGP10 TRANSMITTERS (CONTINUED)**

| <u>Description</u>  | <u>Model</u> |
|---|--------------|
| <b><u>Vent Screw and Block &amp; Bleed Valve</u></b>  |              |
| 316 ss Vent Screw in Process Connection (Not with Structure Codes 32 or 33, or Pressure Seals)                      | -V1          |
| Block and Bleed Valve, Carbon Steel (Not with Pressure Seals)   | -V2          |
| Block and Bleed Valve, 316 ss (Not with Pressure Seals)   | -V3          |
| Block and Bleed Valve, 316 ss w/Monel Trim (Not with Pressure Seals)  | -V4          |
| <b><u>Conduit Thread Adapters (with Electrical Safety Code B only)</u></b>  |              |
| Hawke-Type 1/2 NPT Cable Gland for use with Conduit Connection Codes 1 and 3 only                                   | -A1          |
| M20 Connector for use with Conduit Connection Codes 1 and 3 only  | -A3          |
| <b><u>Electronics Housing Features</u></b>  |              |
| External Zero Adjustment  | -Z1          |
| Custody Transfer Lock and Seal  | -Z2          |
| External Zero Adjustment and Custody Transfer Lock and Seal   | -Z3          |
| <b><u>Custom Factory Configuration</u></b>  |              |
| Full Factory Configuration (Requires Configuration Form to be filled out)   | -C2          |
| <b><u>Cleaning and Preparation</u></b>  |              |
| Unit Degreased - for Silicone Filled Sensors Only<br>Not for Oxygen/Chlorine Service, Option -V1, or Pressure Seals | -X1          |
| Cleaned and Prepared for Oxygen Service - for Inert Filled Sensors Only<br>Not with Option -V1, or Pressure Seals   | -X2          |
| Cleaned and Prepared for Chlorine Service - with Structure Code 33 Only<br>Not with Option -V1, or Pressure Seals   | -X3          |
| <b><u>Instruction Books (Common MI, Brochure, and Full Documentation Set on DVD is Standard)</u></b>                |              |
| Without Instruction Book and DVD - Only "Getting Started" Brochure is supplied                                      | -K1          |
| <b><u>Miscellaneous Optional Selections</u></b>   |              |
| 1/2 B Manometer Process Connection (Not Available with Option -V1 or Pressure Seals)                                | -G           |
| Low Temperature Operative Limit of Electronics Housing Extended Down to -50°C (-58°F) (l) (m)                       | -J           |
| 1/2 Process Connection (1/2 NPT to R 1/2 Adapter) (n)   | -R           |
| Supplemental Customer Tag (Stainless Steel Tag wired onto Transmitter)  | -T           |

- a. Refer to PSS 2A-1C13 F for very high GP versions with upper range limits of 52, 105, and 210 MPa (7500, 15000, and 30000 psi). Refer to PSS 2A-1C13 K and PSS 2A-1C13 L for AP and GP versions for sanitary and pulp/paper industries.
- b. Equivalent to Hastelloy® C.
- c. Both transmitter and pressure seal Model Numbers are required. Refer to PSS 2A-1Z11 A for pressure seal Model Codes.
- d. Direct Connect Seal Models that may be specified are PSTAD, PSFAD, PSFFD, and PSISD.
- e. Remote Mount Seal Models that may be specified are PSFPS, PSFES, PSFAR, PSFFR, PSTAR, PSISR, PSSCR, and PSSSR.
- f. For transmitters with Silicone fill prepared for remote seal by others, specify Structure Code 22 or 52.
- g. For transmitters with Inert fill prepared for remote seal by others, specify Structure Code 23 or 53.
- h. Only available with flameproof transmitter structure codes 52, 53, 60, 61, 62, 63, D5, D6, S5, S6, SH, and SJ.
- i. Cover locks are provided as standard with Electrical Safety Codes D, B, G, and V.
- j. Not available with flameproof transmitter structure codes 52, 53, 60, 61, 62, 63, D5, D6, S5, S6, SH, and SJ.
- k. Mounting sets -M1 to -M6 are not offered with direct mounted seals. However, if a direct mounted PSTAD threaded seal with a 1/4 NPT process connection is used, then a mounting set is recommended. Mounting Sets -M1 to -M6 are also not offered with ATEX Electrical Safety Code D.
- l. Not available with Inert fill in sensor or seal.
- m. -50°C indicates sensor and electronics ambient temperature capabilities. Performance is not assured below -29°C. Sensor damage may occur if process is frozen.
- n. Not available with pressure seals, sanitary or pulp/paper process connectors, or nickel alloy sensors.

## IAP20 AND IGP20 BRACKET-MOUNTED TRANSMITTERS

### Sensor Corrosion Protection

Choice of 316L ss, Co-Ni-Cr, nickel alloy<sup>(3)</sup>, Monel, Tantalum, and Gold-Plated 316L ss materials. High corrosion resistance of Co-Ni-Cr (TI 037-078) means long service life in many difficult applications without the extra cost for exotic materials. Also refer to TI 37-75b for process applicability with Co-Ni-Cr and other wetted parts materials.

### Wide Rangeability

Gauge pressure measurement spans may be as low as 0.12 kPa (0.5 inH<sub>2</sub>O) to as high as 35 MPa (5000 psi) by choosing one of only six sensors, and absolute pressure measurement spans may be as low as 0.87 kPa (3.5 inH<sub>2</sub>O) to as high as 21 MPa (3000 psi) by choosing one of only four sensors. This provides exceptional measurement range capability with a minimum of versions.

### Process Connector

Removable, gasketed process connector (Figure 8) allows a wide range of selections, including 1/4 NPT, 1/2 NPT, Rc 1/4, Rc 1/2, and weld neck connections.

For highly corrosive chemical processes, a 1/2 NPT pvdf (Kynar) insert is installed in the HI-side 316 ss cover and is used as the process connector. In these applications, tantalum is used as the sensor diaphragm material.

Figure 8. Bracket-Mounted Transmitter Shown with Conventional Process Connector

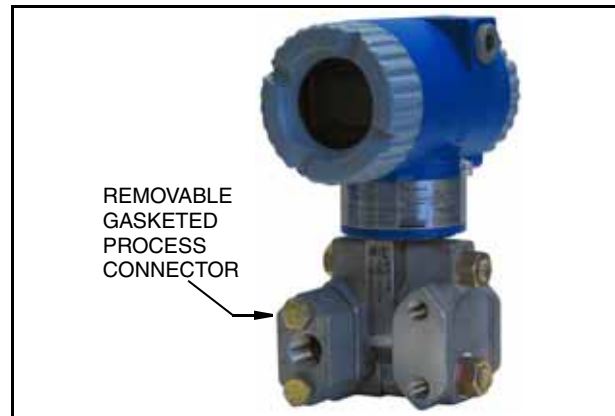

### Flameproof Design

These transmitters are designed to meet Agency flameproof and zone requirements.

### Ease of Mounting Optional Two-Valve Manifold

Two-valve manifold, to isolate transmitter and to vent pressure, is easily mounted directly to transmitter.

### Vacuum Service

An LRL of -100 kPa (-14.7 psi, -1 bar) means that vacuum measurements are easily handled with the versatile IGP20 transmitter.

3. Equivalent to Hastelloy® C.

Table 3. Span and Range Limits for IAP20 and IGP20 Transmitters

| Span Code | Span Limits     |                    |                 | Range Limits (Absolute or Gauge Units) (a) |                     |                   |
|-----------|-----------------|--------------------|-----------------|--|---------------------|-------------------|
|           | kPa             | inH <sub>2</sub> O | mbar            | kPa  | inH <sub>2</sub> O  | mbar              |
| A (b)     | 0.12 and 7.5    | 0.5 and 30         | 1.2 and 75      | -7.5 and +7.5                              | -30 and +30         | -75 and +75       |
| B         | 0.87 (c) and 50 | 3.5 (c) and 200    | 8.7 (c) and 500 | -50 (a) and +50                            | -200 (a) and +200   | -500 (a) and +500 |
| Span Code | MPa             | psi                | bar             | MPa  | psi                 | bar               |
| C         | 0.007 and 0.21  | 1 and 30           | 0.07 and 2.1    | -0.1 (a) and 0.21                          | -14.7 (a) and +30   | -1 (a) and +2.1   |
| D         | 0.07 and 2.1    | 10 and 300         | 0.7 and 21      | -0.1 (a) and 2.1                           | -14.7 (a) and +300  | -1 (a) and +21    |
| E (d)     | 0.7 and 21      | 100 and 3000       | 7 and 210       | -0.1 (a) and 21                            | -14.7 (a) and +3000 | -1 (a) and +210   |
| F (b)     | 1.38 and 35     | 200 and 5000       | 13.8 and 350    | -0.1 and 35                                | -14.7 and +5000     | -1 and +350       |

- a. For absolute pressure transmitters (IAP20), the lower range limit is 0.
- b. Span Codes A and F is applicable to the IGP20 Transmitter only. Also, Span Code A not available when pressure seals are specified.
- c. For IAP20, minimum span for factory calibration is 1.2 kPa (5 inH<sub>2</sub>O, 12.4 mbar). Can be field reranged within limits shown in table.
- d. When certain options are specified, the upper span and range limits are reduced as shown in Table 4.

Table 4. Impact of Certain Options on Span and Range Limits (a)

| Option                    | Description (Also see "MODEL CODE: IAP20 AND IGP20 TRANSMITTERS" on page 24) | Span and Range Limits Derated to: |
|---------------------------|--|-----------------------------------|
| -B3                       | B7M Bolts and Nuts (NACE)  | 20 MPa (2900 psi, 200 bar)        |
| -D1                       | DIN Construction   | 16 MPa (2320 psi, 160 bar)        |
| -D5 or -B1                | DIN Construction or 316 ss Bolting   | 15 MPa (2175 psi, 150 bar)        |
| -D2, -D4, -D6, or -D8 (a) | DIN Construction (a)   | 10 MPa (1500 psi, 100 bar) (a)    |

- a. pp Refer to "MODEL CODE: IAP20 AND IGP20 TRANSMITTERS" on page 24 for application and restrictions related to the items listed in the table.

Table 5. Maximum Overrange and Proof Pressure Ratings for IAP20 and IGP20 Transmitters (a)

| Transmitter Configuration<br>(See “” on page 24 for Description of Options) | Overrange Pressure Rating |      |     | Proof Pressure Rating (b) |       |      |
|---|---------------------------|------|-----|---------------------------|-------|------|
|   | MPa                       | psi  | bar | MPa                       | psi   | bar  |
| Standard with IGP20 Span Code F Only  | 51.8                      | 7500 | 518 | 100                       | 14500 | 1000 |
| Standard (c) or with Option -B2, -D3, or -D7                                | 25                        | 3626 | 250 | 100                       | 14500 | 1000 |
| With Option -B3   | 20                        | 2900 | 200 | 70                        | 11150 | 700  |
| With Option -D1   | 16                        | 2320 | 160 | 64                        | 9280  | 640  |
| With Option -B1 or -D5  | 15                        | 2175 | 150 | 60                        | 8700  | 600  |
| With Option -D2, -D4, -D6, or -D8   | 10                        | 1500 | 100 | 40                        | 6000  | 400  |
| With Structure Codes 78 and 79 (pvd insert)                                 | 2.1                       | 300  | 21  | 8.4                       | 1200  | 84   |

- a. Refer to “MODEL CODE: IAP20 AND IGP20 TRANSMITTERS” on page 24 for application and restrictions related to the items listed in the table.
- b. Proof pressure ratings meet ANSI/ISA Standard S82.03-1988. Unit may become nonfunctional after application of proof pressure.
- c. Standard with IAP20/IGP20 Span Codes A to E.

**Accuracy; Includes Linearity, Hysteresis, and Repeatability**

| Accuracy, % of Span (a) |                               |
|-------------------------|-------------------------------|
| Spans ≥10% URL          | Spans <10% URL                |
| ±0.050%                 | ±[0.015 + 0.0035 (URL/Span)]% |

- a. Add ±0.04% for Span Code A, and ±0.02% for Span Codes E and F.

**NOTE**

Accuracy is at Reference Operating Conditions; Zero-based Calibrations; Co-Ni-Cr or 316L ss sensor with Silicone fluid; URL = upper range limit; and span = calibrated span.

**Stability (Long Term Drift)**

Less than ±0.05% of URL per year over a 5-year period.<sup>(4)</sup>

**Calibration Frequency**

The calibration frequency is five years. The five years is derived using the values of allowable error (% span), TPE (% span), performance margin (% span), and stability (% span/month); where:

$$\text{Calibration Frequency} = \frac{\text{Performance Margin}}{\text{Stability}} = \text{Months}$$

4. Add an additional 0.05% to stability specification for Span Code A.

**Ambient Temperature Effect**

Total effect for a 28°C (50°F) change within Normal Operating Condition limits is:

| Span Code   | Ambient Temperature Effect |
|-------------|----------------------------|
| A (a)       | ±(0.18% URL + 0.025% Span) |
| B and C     | ±(0.03% URL + 0.060% Span) |
| D           | ±(0.05% URL + 0.045% Span) |
| E and F (a) | ±(0.08% URL + 0.025% Span) |

- a. Span Codes A and F applicable to IGP20 Transmitter only.

**Vibration Effect (Total Effect)**

±0.2% of URL per “g” for vibrations in the range of 5 to 500 Hz; with double amplitudes of 6.3 mm (0.25 in) in the range of 5 to 15 Hz, or accelerations of 3 “g” in the range of 15 to 500 Hz, whichever is smaller, for transmitters with aluminum housing; and with double amplitudes of 6.3 mm (0.25 in) in the range of 5 to 9 Hz, or accelerations of 1 “g” in the range of 9 to 500 Hz, whichever is smaller, for transmitters with 316 ss housing.



### Fill Fluid

Silicone Oil or Inert FC43, as specified.

### Pressure Seal Diaphragm Material

Varies with pressure seal selected. See PSS 2A-1Z11 A.

### Process Wetted Materials

#### Process Connection

316L ss, cs, Monel, nickel alloy<sup>(5)</sup>, or pvdf

#### Sensor Diaphragm

316L ss, Co-Ni-Cr, Monel, Tantalum, nickel alloy<sup>(5)</sup>, or Gold-Plated 316L ss

#### Gasket

Glass-filled ptfe

### Approximate Mass

- ▶ 3.5 kg (7.8 lb) – with Aluminum Housing
- ▶ 4.2 kg (9.2 lb) – with Process Connectors
- ▶ Add 1.1 kg (2.4 lb) – with 316 ss Housing
- ▶ Add 0.2 kg (0.4 lb) – with LCD Indicator Option
- ▶ With Pressure Seals: See PSS 2A-1Z11 A.

---

5. Equivalent to Hastelloy® C.

MODEL CODE: IAP20 AND IGP20 TRANSMITTERS

| Description   | Model   |
|---|---|
| I/A Series, Electronic, Bracket-Mounted Absolute Pressure Transmitter                               | IAP20   |
| I/A Series, Electronic, Bracket-Mounted Gauge Pressure Transmitter                                  | IGP20   |
| <b>Electronics Versions and Output Signal</b>   |   |
| Intelligent; Digital FOUNDATION fieldbus (Version -F)   | -F  |
| <b>Structure Code - Select from one of the following three groups:</b>                              |   |
| <b>1. Transmitter</b>   |   |
| <b>Hi-Side Cover</b>  |   |
| <b>Sensor</b>   |   |
| <b>Sensor Fill Fluid</b>  |   |
| Steel   | Co-Ni-Cr                                      |
| Steel   | Co-Ni-Cr                                      |
| Steel   | 316L ss                                       |
| Steel   | 316L ss                                       |
| Steel   | Nickel alloy (a)                              |
| Steel   | Nickel alloy (a)                              |
| 316 ss  | Co-Ni-Cr                                      |
| 316 ss  | Co-Ni-Cr                                      |
| 316 ss  | 316L ss                                       |
| 316 ss  | 316L ss                                       |
| 316 ss  | 316L ss, Gold Plated                          |
| 316 ss  | Monel   |
| 316 ss  | Monel   |
| 316 ss  | Nickel alloy (a)                              |
| 316 ss  | Nickel alloy (a)                              |
| Monel   | Monel   |
| Monel   | Monel   |
| Nickel alloy (a)  | Nickel alloy (a)                              |
| Nickel alloy (a)  | Nickel alloy (a)                              |
| Nickel alloy (a)  | Tantalum                                      |
| Nickel alloy (a)  | Tantalum                                      |
| pvdf Insert (Kynar)   | Tantalum                                      |
| pvdf Insert (Kynar)   | Tantalum                                      |
|   | Silicone (Used with Process Connector Type 7) |
|   | Inert (Used with Process Connector Type 7)    |
|   | 78 (b)  |
|   | 79 (b)  |
| <b>2. Transmitter Prepared for Foxboro Model Coded Seals (c)</b>                                    |   |
| Transmitter Prepared for Remote Seal on HI Side; Silicone fill in sensor (d)                        | S3  |
| Transmitter Prepared for Remote Seal on HI Side; Inert fill in sensor (IGP20 only) (d)              | S4  |
| Transmitter Prepared for PSFLT, PSSCT, or PSSST Seal, HI Side; Silicone fill in sensor (IGP20 only) | F1  |
| Transmitter Prepared for PSFLT, PSSCT, or PSSST Seal, HI Side; Inert fill in sensor (IGP20 only)    | F2  |
| <b>3. Transmitter Prepared for non-Foxboro Seals</b>  |   |
| Transmitter Prepared for Remote Seal; Silicone Fill in Sensor                                       | SC  |
| Transmitter Prepared for Remote Seal; Inert Fill in Sensor  | SD  |

**MODEL CODE: IAP20 AND IGP20 TRANSMITTERS (CONTINUED)**

| Description   | Model        |              |             |  |
|---|--------------|--------------|-------------|--|
| <b>Span Limits (Absolute or Gauge Pressure Units)</b>   |              |              |             |  |
| <table border="0"> <tr> <td><b>kPa</b></td> <td><b>inH2O</b></td> <td><b>mbar</b></td> </tr> </table>   | <b>kPa</b>   | <b>inH2O</b> | <b>mbar</b> |  |
| <b>kPa</b>  | <b>inH2O</b> | <b>mbar</b>  |             |  |
| 0.12 and 7.5  | A (e)        |              |             |  |
| 0.87 and 50   | B            |              |             |  |
| <table border="0"> <tr> <td><b>MPa</b></td> <td><b>psi</b></td> <td><b>bar</b></td> </tr> </table>  | <b>MPa</b>   | <b>psi</b>   | <b>bar</b>  |  |
| <b>MPa</b>  | <b>psi</b>   | <b>bar</b>   |             |  |
| 0.007 and 0.21  | C            |              |             |  |
| 0.07 and 2.1  | D            |              |             |  |
| 0.7 and 21  | E (f)        |              |             |  |
| 1.38 and 35   | F (f)        |              |             |  |
| 13.8 and 350 (IGP20 Only)   |              |              |             |  |
| <b>Process Connector Type (Material Same as Process Cover Material)</b>   |              |              |             |  |
| None; connect directly to process cover (not available with Structure Codes 78 and 79)  | 0            |              |             |  |
| 1/4 NPT (not available with Structure Codes 46, 47, 48, 49, 78, 79)   | 1            |              |             |  |
| 1/2 NPT (not available with Structure Codes 78, 79)   | 2            |              |             |  |
| Rc 1/4 (not available with Structure Codes 46, 47, 48, 49, 78, 79)  | 3            |              |             |  |
| Rc 1/2 (not available with Structure Codes 78, 79)  | 4            |              |             |  |
| 1/2 Schedule 80 Welding Neck (not available with Structure Codes 46, 47, 48, 49, 78, 79)  | 6            |              |             |  |
| None; pvdf (Kynar) insert tapped for 1/2 NPT on side of 316 ss Process Cover (only with Codes 78/79)  | 7            |              |             |  |
| <b>Conduit Connection and Housing Material</b>  |              |              |             |  |
| 1/2 NPT Conduit Connection, Aluminum Housing  | 1            |              |             |  |
| PG 13.5 Conduit Connection, Aluminum Housing (With Electrical Safety Code D only)   | 2            |              |             |  |
| 1/2 NPT Conduit Connection, 316 ss Housing  | 3            |              |             |  |
| PG 13.5 Conduit Connection, 316 ss Housing (With Electrical Safety Code D only)   | 4            |              |             |  |
| M20 Conduit Connection, Both Sides, Aluminum Housing (With Electrical Safety Code D only)   | 5            |              |             |  |
| M20 Conduit Connection, Both Sides, 316 ss Housing (With Electrical Safety Code D only)   | 6            |              |             |  |
| <b>Electrical Safety (See "ELECTRICAL SAFETY SPECIFICATIONS – IAP20 AND IGP20 TRANSMITTERS" on page 12 for Description and Approval Status)</b> |              |              |             |  |
| ATEX Flameproof; II 2 GD, EEx d IIC, Zone 1 (g)   | D            |              |             |  |
| ATEX FISCO Intrinsically Safe; II 1 G, EEx ia IIC, Zone 0   | E            |              |             |  |
| ATEX FNICO protection n; II 3 G, EEx nL IIC, Zone 2   | N            |              |             |  |
| CSA Certifications:   | C            |              |             |  |
| Division 1 explosionproof and dust-ignitionproof  |              |              |             |  |
| FISCO Division 1, Classes I, II, and III  |              |              |             |  |
| FISCO zone certified Ex ia IIC, and energy limited Ex nA II   |              |              |             |  |
| FNICO Division 2, Classes I, II, and III  |              |              |             |  |
| CSA zone certified flameproof, Ex d IIC; also all certifications of Code C above (g)  | B            |              |             |  |
| FM Approvals:   | F            |              |             |  |
| Division 1 explosionproof and dust-ignitionproof  |              |              |             |  |
| FISCO Division 1, Classes I, II, and II   |              |              |             |  |
| FISCO zone approved Ex ia IIC   |              |              |             |  |
| FNICO nonincendive Division 2, Classes I, II, and III   |              |              |             |  |
| FM approved flameproof, AEx d IIC; also all approvals of Code F above (g)   | G            |              |             |  |
| IECEx FISCO intrinsically safe, Ex ia IIC, Zone 0   | T            |              |             |  |
| IECEx flameproof; Ex d IIC, Zone 1 (n)  | V            |              |             |  |
| IECEx FNICO protection n, Ex nL IIC, Zone 2   | U            |              |             |  |

**MODEL CODE: IAP20 AND IGP20 TRANSMITTERS (CONTINUED)**

| Description   | Model                       |                             |                                 |                                 |  |                  |       |               |     |     |   |       |     |       |     |              |       |                |     |     |   |       |      |       |     |                  |        |                |     |     |   |        |      |        |     |              |         |                |     |     |   |         |       |         |     |  |
|---|-----------------------------|-----------------------------|---------------------------------|---------------------------------|--|------------------|-------|---------------|-----|-----|---|-------|-----|-------|-----|--------------|-------|----------------|-----|-----|---|-------|------|-------|-----|------------------|--------|----------------|-----|-----|---|--------|------|--------|-----|--------------|---------|----------------|-----|-----|---|---------|-------|---------|-----|--|
| <b>Optional Selections</b>  |                             |                             |                                 |                                 |  |                  |       |               |     |     |   |       |     |       |     |              |       |                |     |     |   |       |      |       |     |                  |        |                |     |     |   |        |      |        |     |              |         |                |     |     |   |         |       |         |     |  |
| <b><u>Mounting Bracket Set - Not available with Direct Connect Seals, Structure Codes F1 and F2</u></b>   |                             |                             |                                 |                                 |  |                  |       |               |     |     |   |       |     |       |     |              |       |                |     |     |   |       |      |       |     |                  |        |                |     |     |   |        |      |        |     |              |         |                |     |     |   |         |       |         |     |  |
| Standard Style Painted Steel Bracket with Plated Steel Bolts  | -M1                         |                             |                                 |                                 |  |                  |       |               |     |     |   |       |     |       |     |              |       |                |     |     |   |       |      |       |     |                  |        |                |     |     |   |        |      |        |     |              |         |                |     |     |   |         |       |         |     |  |
| Standard Style Stainless Steel Bracket with Stainless Steel Bolts   | -M2                         |                             |                                 |                                 |  |                  |       |               |     |     |   |       |     |       |     |              |       |                |     |     |   |       |      |       |     |                  |        |                |     |     |   |        |      |        |     |              |         |                |     |     |   |         |       |         |     |  |
| Universal Style Stainless Steel Bracket with Stainless Steel Bolts  | -M3                         |                             |                                 |                                 |  |                  |       |               |     |     |   |       |     |       |     |              |       |                |     |     |   |       |      |       |     |                  |        |                |     |     |   |        |      |        |     |              |         |                |     |     |   |         |       |         |     |  |
| <b><u>Digital Indicator with Pushbuttons</u></b>  |                             |                             |                                 |                                 |  |                  |       |               |     |     |   |       |     |       |     |              |       |                |     |     |   |       |      |       |     |                  |        |                |     |     |   |        |      |        |     |              |         |                |     |     |   |         |       |         |     |  |
| Digital Indicator, Pushbuttons, and Window Cover  | -L1                         |                             |                                 |                                 |  |                  |       |               |     |     |   |       |     |       |     |              |       |                |     |     |   |       |      |       |     |                  |        |                |     |     |   |        |      |        |     |              |         |                |     |     |   |         |       |         |     |  |
| <b><u>DIN 19213 Construction with Process Connector Code 0 and 316 ss Process Covers Only (h)</u></b>   |                             |                             |                                 |                                 |  |                  |       |               |     |     |   |       |     |       |     |              |       |                |     |     |   |       |      |       |     |                  |        |                |     |     |   |        |      |        |     |              |         |                |     |     |   |         |       |         |     |  |
| <table border="1"> <thead> <tr> <th data-bbox="164 695 537 722"><b>Process Cover Type</b></th> <th data-bbox="537 695 667 722"><b>Cover Screw Material</b></th> <th data-bbox="667 695 927 722"><b>Size</b></th> <th data-bbox="927 695 1312 722"><b>Connector Screw Material</b></th> <th data-bbox="1317 695 1404 722"></th> </tr> </thead> <tbody> <tr> <td data-bbox="164 722 537 749">Single Ended (i)</td> <td data-bbox="537 722 667 749">Steel</td> <td data-bbox="667 722 927 749">M10 (by User)</td> <td data-bbox="927 722 1312 749">N/A</td> <td data-bbox="1317 722 1404 749">-D1</td> </tr> <tr> <td data-bbox="164 749 537 777">Double Ended (i) (j)<br/>(Blind Kidney Flange on back)</td> <td data-bbox="537 749 667 777">Steel</td> <td data-bbox="667 749 927 777">M10</td> <td data-bbox="927 749 1312 777">Steel</td> <td data-bbox="1317 749 1404 777">-D2</td> </tr> <tr> <td data-bbox="164 777 537 804">Single Ended</td> <td data-bbox="537 777 667 804">Steel</td> <td data-bbox="667 777 927 804">7/16 (by User)</td> <td data-bbox="927 777 1312 804">N/A</td> <td data-bbox="1317 777 1404 804">-D3</td> </tr> <tr> <td data-bbox="164 804 537 831">Double Ended (i) (j)<br/>(Blind Kidney Flange on back)</td> <td data-bbox="537 804 667 831">Steel</td> <td data-bbox="667 804 927 831">7/16</td> <td data-bbox="927 804 1312 831">Steel</td> <td data-bbox="1317 804 1404 831">-D4</td> </tr> <tr> <td data-bbox="164 831 537 858">Single Ended (i)</td> <td data-bbox="537 831 667 858">316 ss</td> <td data-bbox="667 831 927 858">7/16 (by User)</td> <td data-bbox="927 831 1312 858">N/A</td> <td data-bbox="1317 831 1404 858">-D5</td> </tr> <tr> <td data-bbox="164 858 537 886">Double Ended (i) (j)<br/>(Blind Kidney Flange on back)</td> <td data-bbox="537 858 667 886">316 ss</td> <td data-bbox="667 858 927 886">7/16</td> <td data-bbox="927 858 1312 886">316 ss</td> <td data-bbox="1317 858 1404 886">-D6</td> </tr> <tr> <td data-bbox="164 886 537 913">Single Ended</td> <td data-bbox="537 886 667 913">17-4 ss</td> <td data-bbox="667 886 927 913">7/16 (by User)</td> <td data-bbox="927 886 1312 913">N/A</td> <td data-bbox="1317 886 1404 913">-D7</td> </tr> <tr> <td data-bbox="164 913 537 940">Double Ended (i) (j)<br/>(Blind Kidney Flange on back)</td> <td data-bbox="537 913 667 940">17-4 ss</td> <td data-bbox="667 913 927 940">7/16v</td> <td data-bbox="927 913 1312 940">17-4 ss</td> <td data-bbox="1317 913 1404 940">-D8</td> </tr> </tbody> </table> | <b>Process Cover Type</b>   | <b>Cover Screw Material</b> | <b>Size</b>                     | <b>Connector Screw Material</b> |  | Single Ended (i) | Steel | M10 (by User) | N/A | -D1 | Double Ended (i) (j)<br>(Blind Kidney Flange on back) | Steel | M10 | Steel | -D2 | Single Ended | Steel | 7/16 (by User) | N/A | -D3 | Double Ended (i) (j)<br>(Blind Kidney Flange on back) | Steel | 7/16 | Steel | -D4 | Single Ended (i) | 316 ss | 7/16 (by User) | N/A | -D5 | Double Ended (i) (j)<br>(Blind Kidney Flange on back) | 316 ss | 7/16 | 316 ss | -D6 | Single Ended | 17-4 ss | 7/16 (by User) | N/A | -D7 | Double Ended (i) (j)<br>(Blind Kidney Flange on back) | 17-4 ss | 7/16v | 17-4 ss | -D8 |  |
| <b>Process Cover Type</b>   | <b>Cover Screw Material</b> | <b>Size</b>                 | <b>Connector Screw Material</b> |                                 |  |                  |       |               |     |     |   |       |     |       |     |              |       |                |     |     |   |       |      |       |     |                  |        |                |     |     |   |        |      |        |     |              |         |                |     |     |   |         |       |         |     |  |
| Single Ended (i)  | Steel                       | M10 (by User)               | N/A                             | -D1                             |  |                  |       |               |     |     |   |       |     |       |     |              |       |                |     |     |   |       |      |       |     |                  |        |                |     |     |   |        |      |        |     |              |         |                |     |     |   |         |       |         |     |  |
| Double Ended (i) (j)<br>(Blind Kidney Flange on back)   | Steel                       | M10                         | Steel                           | -D2                             |  |                  |       |               |     |     |   |       |     |       |     |              |       |                |     |     |   |       |      |       |     |                  |        |                |     |     |   |        |      |        |     |              |         |                |     |     |   |         |       |         |     |  |
| Single Ended  | Steel                       | 7/16 (by User)              | N/A                             | -D3                             |  |                  |       |               |     |     |   |       |     |       |     |              |       |                |     |     |   |       |      |       |     |                  |        |                |     |     |   |        |      |        |     |              |         |                |     |     |   |         |       |         |     |  |
| Double Ended (i) (j)<br>(Blind Kidney Flange on back)   | Steel                       | 7/16                        | Steel                           | -D4                             |  |                  |       |               |     |     |   |       |     |       |     |              |       |                |     |     |   |       |      |       |     |                  |        |                |     |     |   |        |      |        |     |              |         |                |     |     |   |         |       |         |     |  |
| Single Ended (i)  | 316 ss                      | 7/16 (by User)              | N/A                             | -D5                             |  |                  |       |               |     |     |   |       |     |       |     |              |       |                |     |     |   |       |      |       |     |                  |        |                |     |     |   |        |      |        |     |              |         |                |     |     |   |         |       |         |     |  |
| Double Ended (i) (j)<br>(Blind Kidney Flange on back)   | 316 ss                      | 7/16                        | 316 ss                          | -D6                             |  |                  |       |               |     |     |   |       |     |       |     |              |       |                |     |     |   |       |      |       |     |                  |        |                |     |     |   |        |      |        |     |              |         |                |     |     |   |         |       |         |     |  |
| Single Ended  | 17-4 ss                     | 7/16 (by User)              | N/A                             | -D7                             |  |                  |       |               |     |     |   |       |     |       |     |              |       |                |     |     |   |       |      |       |     |                  |        |                |     |     |   |        |      |        |     |              |         |                |     |     |   |         |       |         |     |  |
| Double Ended (i) (j)<br>(Blind Kidney Flange on back)   | 17-4 ss                     | 7/16v                       | 17-4 ss                         | -D8                             |  |                  |       |               |     |     |   |       |     |       |     |              |       |                |     |     |   |       |      |       |     |                  |        |                |     |     |   |        |      |        |     |              |         |                |     |     |   |         |       |         |     |  |
| <b><u>Cleaning and Preparation - Not Available w/Gold-Plated Sensor, Structure 2G (h)</u></b>   |                             |                             |                                 |                                 |  |                  |       |               |     |     |   |       |     |       |     |              |       |                |     |     |   |       |      |       |     |                  |        |                |     |     |   |        |      |        |     |              |         |                |     |     |   |         |       |         |     |  |
| Unit Degreased - for Silicone Filled Sensors Only   | -X1                         |                             |                                 |                                 |  |                  |       |               |     |     |   |       |     |       |     |              |       |                |     |     |   |       |      |       |     |                  |        |                |     |     |   |        |      |        |     |              |         |                |     |     |   |         |       |         |     |  |
| (Not for Oxygen/Chlorine/Other Fluids that may react with Silicone)   |                             |                             |                                 |                                 |  |                  |       |               |     |     |   |       |     |       |     |              |       |                |     |     |   |       |      |       |     |                  |        |                |     |     |   |        |      |        |     |              |         |                |     |     |   |         |       |         |     |  |
| Cleaned and Prepared for Oxygen Service - for Inert Filled Sensors Only   | -X2                         |                             |                                 |                                 |  |                  |       |               |     |     |   |       |     |       |     |              |       |                |     |     |   |       |      |       |     |                  |        |                |     |     |   |        |      |        |     |              |         |                |     |     |   |         |       |         |     |  |
| (Not available with Carbon Steel Covers or with Silicone Filled Sensors)  |                             |                             |                                 |                                 |  |                  |       |               |     |     |   |       |     |       |     |              |       |                |     |     |   |       |      |       |     |                  |        |                |     |     |   |        |      |        |     |              |         |                |     |     |   |         |       |         |     |  |
| Cleaned and Prepared for Chlorine Service - for Inert Filled Sensors Only (k)   | -X3                         |                             |                                 |                                 |  |                  |       |               |     |     |   |       |     |       |     |              |       |                |     |     |   |       |      |       |     |                  |        |                |     |     |   |        |      |        |     |              |         |                |     |     |   |         |       |         |     |  |
| (Not available with Carbon Steel Covers or with Silicone Filled Sensors)  |                             |                             |                                 |                                 |  |                  |       |               |     |     |   |       |     |       |     |              |       |                |     |     |   |       |      |       |     |                  |        |                |     |     |   |        |      |        |     |              |         |                |     |     |   |         |       |         |     |  |
| <b><u>Bolting for Process Covers/Connectors (l)</u></b>   |                             |                             |                                 |                                 |  |                  |       |               |     |     |   |       |     |       |     |              |       |                |     |     |   |       |      |       |     |                  |        |                |     |     |   |        |      |        |     |              |         |                |     |     |   |         |       |         |     |  |
| 316 ss Bolts and Nuts (Pressure Derated) (i)  | -B1                         |                             |                                 |                                 |  |                  |       |               |     |     |   |       |     |       |     |              |       |                |     |     |   |       |      |       |     |                  |        |                |     |     |   |        |      |        |     |              |         |                |     |     |   |         |       |         |     |  |
| 17-4 ss Bolts and Nuts (m)  | -B2                         |                             |                                 |                                 |  |                  |       |               |     |     |   |       |     |       |     |              |       |                |     |     |   |       |      |       |     |                  |        |                |     |     |   |        |      |        |     |              |         |                |     |     |   |         |       |         |     |  |
| B7M Bolts and Nuts (NACE) (Pressure Derated) (i)  | -B3                         |                             |                                 |                                 |  |                  |       |               |     |     |   |       |     |       |     |              |       |                |     |     |   |       |      |       |     |                  |        |                |     |     |   |        |      |        |     |              |         |                |     |     |   |         |       |         |     |  |
| <b><u>Conduit Thread Adapters</u></b>   |                             |                             |                                 |                                 |  |                  |       |               |     |     |   |       |     |       |     |              |       |                |     |     |   |       |      |       |     |                  |        |                |     |     |   |        |      |        |     |              |         |                |     |     |   |         |       |         |     |  |
| Hawke-Type 1/2 NPT Cable Gland for use with Conduit Connection Codes 1 and 3 (n)  | -A1                         |                             |                                 |                                 |  |                  |       |               |     |     |   |       |     |       |     |              |       |                |     |     |   |       |      |       |     |                  |        |                |     |     |   |        |      |        |     |              |         |                |     |     |   |         |       |         |     |  |
| M20 Connector for use with Conduit Connection Codes 1 and 3 (n)   | -A3                         |                             |                                 |                                 |  |                  |       |               |     |     |   |       |     |       |     |              |       |                |     |     |   |       |      |       |     |                  |        |                |     |     |   |        |      |        |     |              |         |                |     |     |   |         |       |         |     |  |
| <b><u>Electronics Housing Features</u></b>  |                             |                             |                                 |                                 |  |                  |       |               |     |     |   |       |     |       |     |              |       |                |     |     |   |       |      |       |     |                  |        |                |     |     |   |        |      |        |     |              |         |                |     |     |   |         |       |         |     |  |
| External Zero Adjustment  | -Z1                         |                             |                                 |                                 |  |                  |       |               |     |     |   |       |     |       |     |              |       |                |     |     |   |       |      |       |     |                  |        |                |     |     |   |        |      |        |     |              |         |                |     |     |   |         |       |         |     |  |
| Custody Transfer Lock and Seal  | -Z2                         |                             |                                 |                                 |  |                  |       |               |     |     |   |       |     |       |     |              |       |                |     |     |   |       |      |       |     |                  |        |                |     |     |   |        |      |        |     |              |         |                |     |     |   |         |       |         |     |  |
| External Zero Adjustment and Custody Transfer Lock and Seal   | -Z3                         |                             |                                 |                                 |  |                  |       |               |     |     |   |       |     |       |     |              |       |                |     |     |   |       |      |       |     |                  |        |                |     |     |   |        |      |        |     |              |         |                |     |     |   |         |       |         |     |  |
| <b><u>Custom Factory Configuration</u></b>  |                             |                             |                                 |                                 |  |                  |       |               |     |     |   |       |     |       |     |              |       |                |     |     |   |       |      |       |     |                  |        |                |     |     |   |        |      |        |     |              |         |                |     |     |   |         |       |         |     |  |
| Full Factory Configuration (Requires Configuration Form to be filled out)   | -C2                         |                             |                                 |                                 |  |                  |       |               |     |     |   |       |     |       |     |              |       |                |     |     |   |       |      |       |     |                  |        |                |     |     |   |        |      |        |     |              |         |                |     |     |   |         |       |         |     |  |

**MODEL CODE: IAP20 AND IGP20 TRANSMITTERS (CONTINUED)**

| Description  | Model  |
|--|--------|
| <b><u>Tubing Connectors - Specify Only One (Only 316 ss process covers; no side vents on cover) (h)</u></b>  |        |
| Steel, Connecting 6 mm Tubing to 1/4 NPT Process Connector   | -E1    |
| Steel, Connecting 12 mm Tubing to 1/2 NPT Process Connector  | -E2    |
| 316 ss, Connecting 6 mm Tubing to 1/4 NPT Process Connector  | -E3    |
| 316 ss, Connecting 12 mm Tubing to 1/2 NPT Process Connector   | -E4    |
| <b><u>Gaskets</u></b>  |        |
| Gasket for Vacuum Service with Pressure Seals (o)  | -G1    |
| <b><u>Instruction Books (Common MI, Brochure, and Full Documentation Set on DVD is Standard)</u></b>   |        |
| Without Instruction Book and DVD - Only "Getting Started" Brochure is supplied   | -K1    |
| <b><u>Miscellaneous Optional Selections</u></b>  |        |
| Low Temperature Operative Limit of Electronics Housing Extended Down to -50°C (-58°F) (p)<br>Not available with sensors and seals with Inert fill, Structure Codes 78 and 79,<br>or DIN Options -D2, -D4, -D6, and -D8 | -J     |
| Vent Screw in side of Process Cover (with 316 ss process covers only)  | -V (h) |
| Not available with seals, DIN construction options, or Structure Codes 78 and 79   |        |
| Supplemental Customer Tag (Stainless Steel Tag wired onto Transmitter)   | -T     |
| Examples: IGP20-F20B21F-M1Z2; IAP20-FS3C11F-T  |        |

- a. Equivalent to Hastelloy® C.
- b. Maximum overrange pressure is 2.1 MPa (300 psi); temperature limits are -7 and +82°C (20 and 180°F).
- c. Transmitter and Pressure Seal Model Codes are both required. See PSS 2A-1Z11 A for the various pressure seal model codes.
- d. Remote Seal Models that may be specified are PSFPS, PSFES, PSFAR, PSFFR, PSTAR, PSISR, PSSCR, and PSSSR.
- e. Span Limit Code A is not available with pressure seals (Structure Codes F1, F2, S3, S4, SC, SD).
- f. Span Codes E and F not available with Structure Codes 78 and 79 (pvdf insert in HI Side Cover).
- g. Cover locks are provided as standard with Electrical Safety Codes D, B, G, and V.
- h. Not available when Remote Mount or Direct Connect Pressure Seals are specified.
- i. Pressure derated. See derating table in specifications section.
- j. Temperature limits derated to 0 and 60°C (32 and 140°F). Also Mounting Sets -M1 and -M2 not available.
- k. Only available with Structure Codes 21, 23, 25, 27, 35, 47, 49, and 79.
- l. Not available with DIN construction options. For stainless steel bolts with DIN construction, specify -D5 to -D8, as required.
- m. When -X3 is specified, the standard bolting is replaced with 17-4 ss bolts and nuts. Therefore, there is no need to specify Option -B2 when selecting the Chlorine Service Option -X3.
- n. Available with Electrical Safety Code D only.
- o. Standard offering with IAP20 Transmitters when pressure seals are used. However, -G1 is a required option with IGP20 Transmitters when pressure seal (Structure Codes S3, S4, F1, F2, SC, and SD) will be used in vacuum applications. This option substitutes vacuum service metal gasket for standard ptfе process cover gasket.
- p. -50°C indicates sensor and electronics ambient temperature capabilities. Performance is not assured below -29°C. Sensor damage may occur if process is frozen.

IDP10 DIFFERENTIAL PRESSURE TRANSMITTERS

IDP10 Transmitter Structures

Invensys offers a traditional, and two low profile structures (LP1 and LP2).

Figure 9. IDP10 Differential Pressure Transmitter

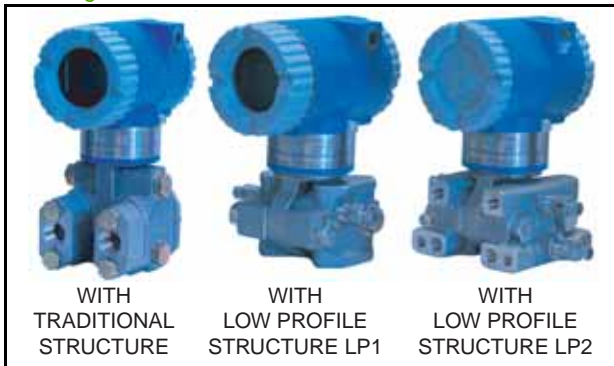

Traditional Structure (Figure 10)

This structure uses a design where the process connections are at 90° from the transmitter centerline. Vertical and horizontal mounting are provided for sensor cavity venting and draining.

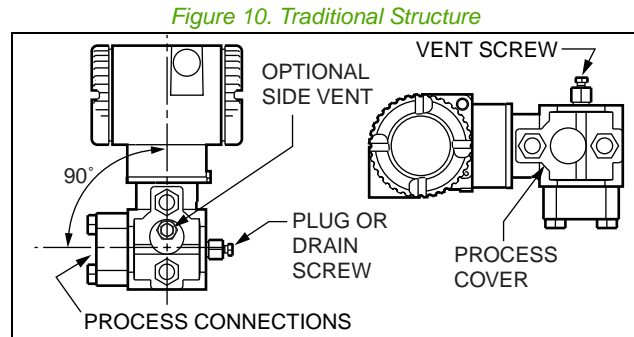

Low Profile Structure LP1 (Figure 11)

This structure provides process connections that are in line with the transmitter centerline. It is compact, and its light weight is ideal for direct mounting to process piping or manifold. An optional adapter plate (Options -P1 to -P8), shown in Figure 12 with the LP2, is offered for mounting to a Coplanar™ manifold. Sensor cavity venting and draining is provided for both vertical and horizontal installations.

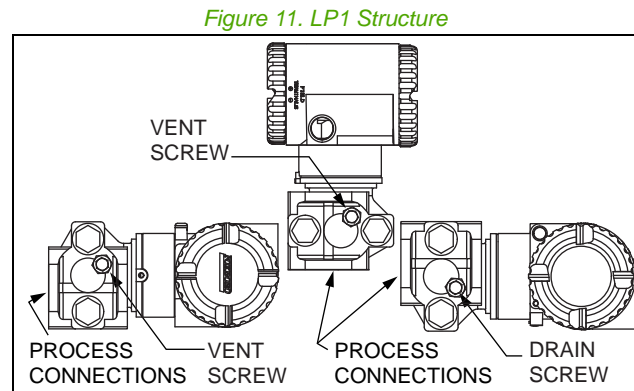

Low Profile Structure LP2 (Figure 12)

This structure, as with the LP1, is an in-line design which can be direct or bracket mounted. It is used for vertical installations, and can also be installed on existing Coplanar manifolds using an adapter plate (Options -P1 to -P8). Sensor cavity venting and draining are also provided.

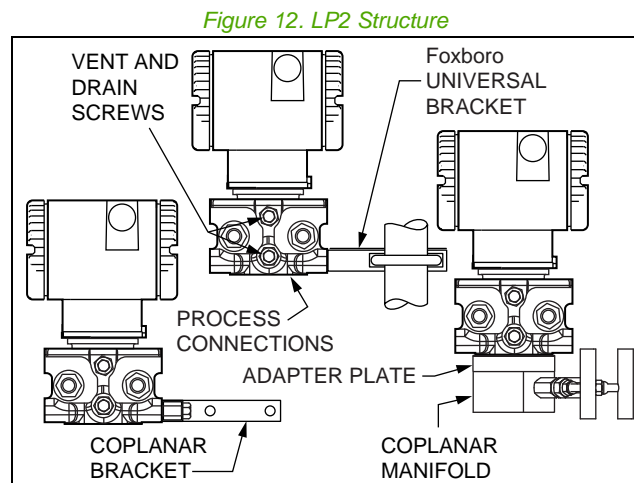

**Span and Range Limits for IDP10 d/p Cell Transmitters (a)**

| Span Code | Span Limits    |                    |               | Range Limits     |                    |                   |
|-----------|----------------|--------------------|---------------|------------------|--------------------|-------------------|
|           | kPa            | inH <sub>2</sub> O | mbar          | kPa              | inH <sub>2</sub> O | mbar              |
| A (b)     | 0.12 and 7.5   | 0.5 and 30         | 1.2 and 75    | -7.5 and +7.5    | -30 and +30        | -75 and +75       |
| B         | 0.87 and 50    | 3.5 and 200        | 8.7 and 500   | -50 and +50      | -200 and +200      | -500 and +500     |
| C         | 7 and 210      | 28 and 840         | 70 and 2100   | -210 and +210    | -840 and +840      | -2100 and +2100   |
| D         | 0.07 and 2.1   | 10 and 300         | 0.7 and 21    | -0.21 and +2.1   | -30 and +300       | -2.1 and +21      |
| E (c)     | 0.7 and 21 (c) | 100 and 3000 (c)   | 7 and 210 (c) | -0.21 and 21 (c) | -30 and +3000 (c)  | -2.1 and +210 (c) |

- a. Positive values indicate HI side of sensor at the high pressure, and negative values indicate LO side of sensor at the high pressure.
- b. Span Limit Code A not available when pressure seals are selected.
- c. When certain options are specified, the upper span and range limits are reduced as shown in the “Options Impact” on next page.

**Maximum Static and Proof Pressure Ratings for IDP10 d/p Cell Transmitters (a)**

| Transmitter Configuration<br>(See “MODEL CODE: IDP10 TRANSMITTER” on page 32 for Description of Options) | Static Pressure Rating |      |     | Proof Pressure Rating (b) |       |      |
|--|------------------------|------|-----|---------------------------|-------|------|
|  | MPa                    | psi  | bar | MPa                       | psi   | bar  |
| With Option -D9 or -Y  | 40                     | 5800 | 400 | 100                       | 14500 | 1000 |
| Standard or with Option -B2, -D3, or -D7   | 25                     | 3626 | 250 | 100                       | 14500 | 1000 |
| With Option -B3  | 20                     | 2900 | 200 | 70                        | 11150 | 700  |
| With Option -D1  | 16                     | 2320 | 160 | 64                        | 9280  | 640  |
| With Option -B1 or -D5   | 15                     | 2175 | 150 | 60                        | 8700  | 600  |
| With Option -D2, -D4, -D6, or -D8  | 10                     | 1500 | 100 | 40                        | 6000  | 400  |
| With Structure Codes 78 and 79 (pvdf insert)   | 2.1                    | 300  | 21  | 8.4                       | 1200  | 84   |

- a. Refer to “MODEL CODE: IDP10 TRANSMITTER” on page 32 for application and restrictions related to the items listed in the table.
- b. Proof pressure ratings meet ANSI/ISA Standard S82.03-1988. Unit may become nonfunctional after application of proof pressure.

**Impact of Certain Options on Span and Range Limits (a)**

| Option                    | Description (Also see “MODEL CODE: IDP10 TRANSMITTER” on page 32) | Span and Range Limits Derated to: |
|---------------------------|---|-----------------------------------|
| -B3                       | B7M Bolts and Nuts (NACE)   | 20 MPa (2900 psi, 200 bar)        |
| -D1                       | DIN Construction  | 16 MPa (2320 psi, 160 bar)        |
| -D5 or -B1                | DIN Construction or 316 ss Bolting                                | 15 MPa (2175 psi, 150 bar)        |
| -D2, -D4, -D6, or -D8 (a) | DIN Construction (a)  | 10 MPa (1500 psi, 100 bar) (a)    |

- a. Refer to “MODEL CODE: IDP10 TRANSMITTER” on page 32 for application and restrictions related to the items listed in the table.



### Wide Rangeability

Five d/p Cell range sensors cover measurement spans from 0.125 kPa to 21 MPa (0.5 inH<sub>2</sub>O to 3000 psi). This high turndown capability means that most differential pressure applications are satisfied with only these five ranges, simplifying your spare transmitter and spare parts requirements.

### Sensor Corrosion Protection

Choice of 316L ss, Co-Ni-Cr, nickel alloy<sup>(6)</sup>, Monel, Gold-Plated 316L ss, and Tantalum materials. High corrosion resistance of Co-Ni-Cr (TI 037-078) means long service life without extra cost for exotic materials. See TI 37-75b for process applicability with Co-Ni-Cr and other wetted parts materials.

### Flameproof Design

Meet Agency flameproof and zone requirements.

### Process Connectors

Removable, gasketed process connectors allow a wide range of selections, including 1/4 NPT, 1/2 NPT, Rc 1/4, Rc 1/2, and weld neck connections.

For very corrosive chemical processes, 1/2 NPT pvdf inserts are installed in the HI- and LO- side 316 ss covers and used as the process connectors or the IDP10 traditional structure (see below).

### Accuracy (Linear Output) - Table 1 (a)

| Accuracy, % of Span (b) |                               |
|-------------------------|-------------------------------|
| Spans ≥10% URL          | Spans <10% URL                |
| ±0.050%                 | ±[0.015 + 0.0035 (URL/Span)]% |

- a. Accuracy includes Linearity, Hysteresis, and Repeatability.  
b. Add ±0.04% for Span Code A, and ±0.02% for Span Code E.

### Accuracy (Square Root Output) (a)

| Operating Point % of Flow Rate Span | Accuracy % of Flow Rate Span   |
|-------------------------------------|--|
| 50% and Greater                     | Linear Output Accuracy % from Table 1  |
| Less than 50% (to cutoff)           | $\frac{(\text{Accuracy \% from Table 1})(50)}{\text{Operating Point in \% of Flow Rate Span}}$ |

- a. Accuracy includes Linearity, Hysteresis, and Repeatability.

### NOTE

Accuracy stated is under Reference Operating Conditions; Zero-based Calibrations; Co-Ni-Cr or 316L ss sensor with Silicone fluid; URL = upper range limit; and span = calibrated span.

### Stability (Long Term Drift)

Less than ±0.05% of URL per year over a 5-year period.<sup>(7)</sup>

### Calibration Frequency

The calibration frequency is five years. The five years is derived using the values of allowable error (% span), TPE (% span), performance margin (% span), and stability (% span/month); where:

$$\text{Calibration Frequency} = \frac{\text{Performance Margin}}{\text{Stability}} = \text{Months}$$

6. Equivalent to Hastelloy® C.

7. Add an additional 0.05% to stability specification for Span Code A.

**Static Pressure Effect on Differential Pressure**

The zero and span shift for a 7 MPa, 1000 psi, change in static pressure is:

**Zero Shift (a)**

| Span Code | Zero Shift-Static Pressure Effect |
|-----------|-----------------------------------|
| A         | ± 0.30% URL (b)                   |
| B and C   | ± 0.10% URL                       |
| D         | ± 0.50% URL (b)                   |
| E         | ± 0.50% URL                       |

- a. Can be calibrated out by zeroing at nominal line pressure.
- b. Per 3.5 MPa (500 psi) for Span Codes A and D.

**Span Shift**

±0.25% Reading (±0.030% for Span Code A)

**Ambient Temperature Effect**

Total effect for a 28°C (50°F) change within Normal Operating Condition limits is:

| Span Code | Ambient Temperature Effect (a) |
|-----------|--------------------------------|
| A (b)     | ± (0.18% URL + 0.025% Span)    |
| B and C   | ± (0.03% URL + 0.060% Span)    |
| D         | ± (0.05% URL + 0.045% Span)    |
| E         | ± (0.08% URL + 0.025% Span)    |

- a. See PSS 2A-1Z11 A for additive effect with pressure seals.
- b. Span Limit Code A not applicable to transmitters with pressure seals.

**NOTE**

For additional ambient temperature effect when pressure seals are used, see PSS 2A-1Z11 A.

**Vibration Effect (Total Effect)**

±0.2% of URL per “g” for vibrations in the range of 5 to 500 Hz; with double amplitudes of 6.3 mm (0.25 in) in the range of 5 to 15 Hz, or accelerations of 3 “g” in the range of 15 to 500 Hz, whichever is smaller, for transmitters with aluminum housings; and with double amplitudes of 6.3 mm (0.25 in) in the range of 5 to 9 Hz, or accelerations of 1 “g” in the range of 9 to 500 Hz, whichever is smaller, for transmitters with 316 ss housings.

**Process Wetted Materials**

**Process Connection**

316L ss, cs, Monel, nickel alloy<sup>(8)</sup>, or pvdf

**Sensor Diaphragm**

316L ss, Co-Ni-Cr, Monel, Tantalum, nickel alloy<sup>(8)</sup>, or gold-plated 316L ss

**Gasket**

Glass-filled ptfe

**Pressure Seal Diaphragm Material**

Varies with pressure seal selected. See PSS 2A-1Z11 A.

**Fill Fluid**

Silicone Oil or Inert FC43.

**Approximate Mass (with Process Connectors)**

- ▶ 4.2 kg (9.2 lb) – with Traditional Structure
- ▶ Add 0.1 kg (0.2 lb) – with Low Profile Structure LP1
- ▶ Add 0.8 kg (1.8 lb) – with Low Profile Structure LP2
- ▶ Add 1.1 kg (2.4 lb) – with 316 ss Housing
- ▶ Add 0.2 kg (0.4 lb) – with LCD Indicator Option

8. Equivalent to Hastelloy® C.

**MODEL CODE: IDP10 TRANSMITTER**

| Description  | Model                |   |                   |  |        |          |          |    |        |          |       |    |        |                  |          |    |        |                  |       |    |       |                  |          |    |       |                  |       |    |        |          |          |    |        |          |       |    |        |         |          |    |        |         |       |    |        |                      |          |    |        |       |          |    |        |       |       |    |        |                  |          |    |        |                  |       |    |       |       |          |    |       |       |       |    |                  |                  |          |    |                  |                  |       |    |                  |          |          |    |                  |          |       |    |                     |          |   |        |                     |          |  |        |  |
|--|----------------------|---|-------------------|--|--------|----------|----------|----|--------|----------|-------|----|--------|------------------|----------|----|--------|------------------|-------|----|-------|------------------|----------|----|-------|------------------|-------|----|--------|----------|----------|----|--------|----------|-------|----|--------|---------|----------|----|--------|---------|-------|----|--------|----------------------|----------|----|--------|-------|----------|----|--------|-------|-------|----|--------|------------------|----------|----|--------|------------------|-------|----|-------|-------|----------|----|-------|-------|-------|----|------------------|------------------|----------|----|------------------|------------------|-------|----|------------------|----------|----------|----|------------------|----------|-------|----|---------------------|----------|---|--------|---------------------|----------|--|--------|--|
| I/A Series, Electronic d/p Cell Transmitter for Differential Pressure Measurement  | IDP10                |   |                   |  |        |          |          |    |        |          |       |    |        |                  |          |    |        |                  |       |    |       |                  |          |    |       |                  |       |    |        |          |          |    |        |          |       |    |        |         |          |    |        |         |       |    |        |                      |          |    |        |       |          |    |        |       |       |    |        |                  |          |    |        |                  |       |    |       |       |          |    |       |       |       |    |                  |                  |          |    |                  |                  |       |    |                  |          |          |    |                  |          |       |    |                     |          |   |        |                     |          |  |        |  |
| <b>Electronics Versions and Output Signal</b>  |                      |   |                   |  |        |          |          |    |        |          |       |    |        |                  |          |    |        |                  |       |    |       |                  |          |    |       |                  |       |    |        |          |          |    |        |          |       |    |        |         |          |    |        |         |       |    |        |                      |          |    |        |       |          |    |        |       |       |    |        |                  |          |    |        |                  |       |    |       |       |          |    |       |       |       |    |                  |                  |          |    |                  |                  |       |    |                  |          |          |    |                  |          |       |    |                     |          |   |        |                     |          |  |        |  |
| Intelligent; Digital, FOUNDATION Fieldbus (Version -F)   | -F                   |   |                   |  |        |          |          |    |        |          |       |    |        |                  |          |    |        |                  |       |    |       |                  |          |    |       |                  |       |    |        |          |          |    |        |          |       |    |        |         |          |    |        |         |       |    |        |                      |          |    |        |       |          |    |        |       |       |    |        |                  |          |    |        |                  |       |    |       |       |          |    |       |       |       |    |                  |                  |          |    |                  |                  |       |    |                  |          |          |    |                  |          |       |    |                     |          |   |        |                     |          |  |        |  |
| <b>Structure Code - Select from one of the following six groups:</b>   |                      |   |                   |  |        |          |          |    |        |          |       |    |        |                  |          |    |        |                  |       |    |       |                  |          |    |       |                  |       |    |        |          |          |    |        |          |       |    |        |         |          |    |        |         |       |    |        |                      |          |    |        |       |          |    |        |       |       |    |        |                  |          |    |        |                  |       |    |       |       |          |    |       |       |       |    |                  |                  |          |    |                  |                  |       |    |                  |          |          |    |                  |          |       |    |                     |          |   |        |                     |          |  |        |  |
| <b>1. Transmitter with Traditional Structure</b>   |                      |   |                   |  |        |          |          |    |        |          |       |    |        |                  |          |    |        |                  |       |    |       |                  |          |    |       |                  |       |    |        |          |          |    |        |          |       |    |        |         |          |    |        |         |       |    |        |                      |          |    |        |       |          |    |        |       |       |    |        |                  |          |    |        |                  |       |    |       |       |          |    |       |       |       |    |                  |                  |          |    |                  |                  |       |    |                  |          |          |    |                  |          |       |    |                     |          |   |        |                     |          |  |        |  |
| <table border="0"> <thead> <tr> <th data-bbox="224 674 380 701">Hi-Side Cover</th> <th data-bbox="461 674 542 701">Sensor</th> <th data-bbox="748 674 932 701">Sensor Fill Fluid</th> <th data-bbox="1321 674 1404 701"></th> </tr> </thead> <tbody> <tr> <td>Steel</td> <td>Co-Ni-Cr</td> <td>Silicone</td> <td>10</td> </tr> <tr> <td>Steel</td> <td>Co-Ni-Cr</td> <td>Inert</td> <td>11</td> </tr> <tr> <td>Steel</td> <td>316L ss</td> <td>Silicone</td> <td>12</td> </tr> <tr> <td>Steel</td> <td>316L ss</td> <td>Inert</td> <td>13</td> </tr> <tr> <td>Steel</td> <td>Nickel alloy (a)</td> <td>Silicone</td> <td>16</td> </tr> <tr> <td>Steel</td> <td>Nickel alloy (a)</td> <td>Inert</td> <td>17</td> </tr> <tr> <td>316 ss</td> <td>Co-Ni-Cr</td> <td>Silicone</td> <td>20</td> </tr> <tr> <td>316 ss</td> <td>Co-Ni-Cr</td> <td>Inert</td> <td>21</td> </tr> <tr> <td>316 ss</td> <td>316L ss</td> <td>Silicone</td> <td>22</td> </tr> <tr> <td>316 ss</td> <td>316L ss</td> <td>Inert</td> <td>23</td> </tr> <tr> <td>316 ss</td> <td>316L ss, Gold Plated</td> <td>Silicone</td> <td>2G</td> </tr> <tr> <td>316 ss</td> <td>Monel</td> <td>Silicone</td> <td>24</td> </tr> <tr> <td>316 ss</td> <td>Monel</td> <td>Inert</td> <td>25</td> </tr> <tr> <td>316 ss</td> <td>Nickel alloy (a)</td> <td>Silicone</td> <td>26</td> </tr> <tr> <td>316 ss</td> <td>Nickel alloy (a)</td> <td>Inert</td> <td>27</td> </tr> <tr> <td>Monel</td> <td>Monel</td> <td>Silicone</td> <td>34</td> </tr> <tr> <td>Monel</td> <td>Monel</td> <td>Inert</td> <td>35</td> </tr> <tr> <td>Nickel alloy (a)</td> <td>Nickel alloy (a)</td> <td>Silicone</td> <td>46</td> </tr> <tr> <td>Nickel alloy (a)</td> <td>Nickel alloy (a)</td> <td>Inert</td> <td>47</td> </tr> <tr> <td>Nickel alloy (a)</td> <td>Tantalum</td> <td>Silicone</td> <td>48</td> </tr> <tr> <td>Nickel alloy (a)</td> <td>Tantalum</td> <td>Inert</td> <td>49</td> </tr> <tr> <td>pvdF Insert (Kynar)</td> <td>Tantalum</td> <td>Silicone (Used with Process Connector Type 7)</td> <td>78 (b)</td> </tr> <tr> <td>pvdF Insert (Kynar)</td> <td>Tantalum</td> <td>Inert (Used with Process Connector Type 7)</td> <td>79 (b)</td> </tr> </tbody> </table> | Hi-Side Cover        | Sensor  | Sensor Fill Fluid |  | Steel  | Co-Ni-Cr | Silicone | 10 | Steel  | Co-Ni-Cr | Inert | 11 | Steel  | 316L ss          | Silicone | 12 | Steel  | 316L ss          | Inert | 13 | Steel | Nickel alloy (a) | Silicone | 16 | Steel | Nickel alloy (a) | Inert | 17 | 316 ss | Co-Ni-Cr | Silicone | 20 | 316 ss | Co-Ni-Cr | Inert | 21 | 316 ss | 316L ss | Silicone | 22 | 316 ss | 316L ss | Inert | 23 | 316 ss | 316L ss, Gold Plated | Silicone | 2G | 316 ss | Monel | Silicone | 24 | 316 ss | Monel | Inert | 25 | 316 ss | Nickel alloy (a) | Silicone | 26 | 316 ss | Nickel alloy (a) | Inert | 27 | Monel | Monel | Silicone | 34 | Monel | Monel | Inert | 35 | Nickel alloy (a) | Nickel alloy (a) | Silicone | 46 | Nickel alloy (a) | Nickel alloy (a) | Inert | 47 | Nickel alloy (a) | Tantalum | Silicone | 48 | Nickel alloy (a) | Tantalum | Inert | 49 | pvdF Insert (Kynar) | Tantalum | Silicone (Used with Process Connector Type 7) | 78 (b) | pvdF Insert (Kynar) | Tantalum | Inert (Used with Process Connector Type 7) | 79 (b) |  |
| Hi-Side Cover  | Sensor               | Sensor Fill Fluid                             |                   |  |        |          |          |    |        |          |       |    |        |                  |          |    |        |                  |       |    |       |                  |          |    |       |                  |       |    |        |          |          |    |        |          |       |    |        |         |          |    |        |         |       |    |        |                      |          |    |        |       |          |    |        |       |       |    |        |                  |          |    |        |                  |       |    |       |       |          |    |       |       |       |    |                  |                  |          |    |                  |                  |       |    |                  |          |          |    |                  |          |       |    |                     |          |   |        |                     |          |  |        |  |
| Steel  | Co-Ni-Cr             | Silicone                                      | 10                |  |        |          |          |    |        |          |       |    |        |                  |          |    |        |                  |       |    |       |                  |          |    |       |                  |       |    |        |          |          |    |        |          |       |    |        |         |          |    |        |         |       |    |        |                      |          |    |        |       |          |    |        |       |       |    |        |                  |          |    |        |                  |       |    |       |       |          |    |       |       |       |    |                  |                  |          |    |                  |                  |       |    |                  |          |          |    |                  |          |       |    |                     |          |   |        |                     |          |  |        |  |
| Steel  | Co-Ni-Cr             | Inert   | 11                |  |        |          |          |    |        |          |       |    |        |                  |          |    |        |                  |       |    |       |                  |          |    |       |                  |       |    |        |          |          |    |        |          |       |    |        |         |          |    |        |         |       |    |        |                      |          |    |        |       |          |    |        |       |       |    |        |                  |          |    |        |                  |       |    |       |       |          |    |       |       |       |    |                  |                  |          |    |                  |                  |       |    |                  |          |          |    |                  |          |       |    |                     |          |   |        |                     |          |  |        |  |
| Steel  | 316L ss              | Silicone                                      | 12                |  |        |          |          |    |        |          |       |    |        |                  |          |    |        |                  |       |    |       |                  |          |    |       |                  |       |    |        |          |          |    |        |          |       |    |        |         |          |    |        |         |       |    |        |                      |          |    |        |       |          |    |        |       |       |    |        |                  |          |    |        |                  |       |    |       |       |          |    |       |       |       |    |                  |                  |          |    |                  |                  |       |    |                  |          |          |    |                  |          |       |    |                     |          |   |        |                     |          |  |        |  |
| Steel  | 316L ss              | Inert   | 13                |  |        |          |          |    |        |          |       |    |        |                  |          |    |        |                  |       |    |       |                  |          |    |       |                  |       |    |        |          |          |    |        |          |       |    |        |         |          |    |        |         |       |    |        |                      |          |    |        |       |          |    |        |       |       |    |        |                  |          |    |        |                  |       |    |       |       |          |    |       |       |       |    |                  |                  |          |    |                  |                  |       |    |                  |          |          |    |                  |          |       |    |                     |          |   |        |                     |          |  |        |  |
| Steel  | Nickel alloy (a)     | Silicone                                      | 16                |  |        |          |          |    |        |          |       |    |        |                  |          |    |        |                  |       |    |       |                  |          |    |       |                  |       |    |        |          |          |    |        |          |       |    |        |         |          |    |        |         |       |    |        |                      |          |    |        |       |          |    |        |       |       |    |        |                  |          |    |        |                  |       |    |       |       |          |    |       |       |       |    |                  |                  |          |    |                  |                  |       |    |                  |          |          |    |                  |          |       |    |                     |          |   |        |                     |          |  |        |  |
| Steel  | Nickel alloy (a)     | Inert   | 17                |  |        |          |          |    |        |          |       |    |        |                  |          |    |        |                  |       |    |       |                  |          |    |       |                  |       |    |        |          |          |    |        |          |       |    |        |         |          |    |        |         |       |    |        |                      |          |    |        |       |          |    |        |       |       |    |        |                  |          |    |        |                  |       |    |       |       |          |    |       |       |       |    |                  |                  |          |    |                  |                  |       |    |                  |          |          |    |                  |          |       |    |                     |          |   |        |                     |          |  |        |  |
| 316 ss   | Co-Ni-Cr             | Silicone                                      | 20                |  |        |          |          |    |        |          |       |    |        |                  |          |    |        |                  |       |    |       |                  |          |    |       |                  |       |    |        |          |          |    |        |          |       |    |        |         |          |    |        |         |       |    |        |                      |          |    |        |       |          |    |        |       |       |    |        |                  |          |    |        |                  |       |    |       |       |          |    |       |       |       |    |                  |                  |          |    |                  |                  |       |    |                  |          |          |    |                  |          |       |    |                     |          |   |        |                     |          |  |        |  |
| 316 ss   | Co-Ni-Cr             | Inert   | 21                |  |        |          |          |    |        |          |       |    |        |                  |          |    |        |                  |       |    |       |                  |          |    |       |                  |       |    |        |          |          |    |        |          |       |    |        |         |          |    |        |         |       |    |        |                      |          |    |        |       |          |    |        |       |       |    |        |                  |          |    |        |                  |       |    |       |       |          |    |       |       |       |    |                  |                  |          |    |                  |                  |       |    |                  |          |          |    |                  |          |       |    |                     |          |   |        |                     |          |  |        |  |
| 316 ss   | 316L ss              | Silicone                                      | 22                |  |        |          |          |    |        |          |       |    |        |                  |          |    |        |                  |       |    |       |                  |          |    |       |                  |       |    |        |          |          |    |        |          |       |    |        |         |          |    |        |         |       |    |        |                      |          |    |        |       |          |    |        |       |       |    |        |                  |          |    |        |                  |       |    |       |       |          |    |       |       |       |    |                  |                  |          |    |                  |                  |       |    |                  |          |          |    |                  |          |       |    |                     |          |   |        |                     |          |  |        |  |
| 316 ss   | 316L ss              | Inert   | 23                |  |        |          |          |    |        |          |       |    |        |                  |          |    |        |                  |       |    |       |                  |          |    |       |                  |       |    |        |          |          |    |        |          |       |    |        |         |          |    |        |         |       |    |        |                      |          |    |        |       |          |    |        |       |       |    |        |                  |          |    |        |                  |       |    |       |       |          |    |       |       |       |    |                  |                  |          |    |                  |                  |       |    |                  |          |          |    |                  |          |       |    |                     |          |   |        |                     |          |  |        |  |
| 316 ss   | 316L ss, Gold Plated | Silicone                                      | 2G                |  |        |          |          |    |        |          |       |    |        |                  |          |    |        |                  |       |    |       |                  |          |    |       |                  |       |    |        |          |          |    |        |          |       |    |        |         |          |    |        |         |       |    |        |                      |          |    |        |       |          |    |        |       |       |    |        |                  |          |    |        |                  |       |    |       |       |          |    |       |       |       |    |                  |                  |          |    |                  |                  |       |    |                  |          |          |    |                  |          |       |    |                     |          |   |        |                     |          |  |        |  |
| 316 ss   | Monel                | Silicone                                      | 24                |  |        |          |          |    |        |          |       |    |        |                  |          |    |        |                  |       |    |       |                  |          |    |       |                  |       |    |        |          |          |    |        |          |       |    |        |         |          |    |        |         |       |    |        |                      |          |    |        |       |          |    |        |       |       |    |        |                  |          |    |        |                  |       |    |       |       |          |    |       |       |       |    |                  |                  |          |    |                  |                  |       |    |                  |          |          |    |                  |          |       |    |                     |          |   |        |                     |          |  |        |  |
| 316 ss   | Monel                | Inert   | 25                |  |        |          |          |    |        |          |       |    |        |                  |          |    |        |                  |       |    |       |                  |          |    |       |                  |       |    |        |          |          |    |        |          |       |    |        |         |          |    |        |         |       |    |        |                      |          |    |        |       |          |    |        |       |       |    |        |                  |          |    |        |                  |       |    |       |       |          |    |       |       |       |    |                  |                  |          |    |                  |                  |       |    |                  |          |          |    |                  |          |       |    |                     |          |   |        |                     |          |  |        |  |
| 316 ss   | Nickel alloy (a)     | Silicone                                      | 26                |  |        |          |          |    |        |          |       |    |        |                  |          |    |        |                  |       |    |       |                  |          |    |       |                  |       |    |        |          |          |    |        |          |       |    |        |         |          |    |        |         |       |    |        |                      |          |    |        |       |          |    |        |       |       |    |        |                  |          |    |        |                  |       |    |       |       |          |    |       |       |       |    |                  |                  |          |    |                  |                  |       |    |                  |          |          |    |                  |          |       |    |                     |          |   |        |                     |          |  |        |  |
| 316 ss   | Nickel alloy (a)     | Inert   | 27                |  |        |          |          |    |        |          |       |    |        |                  |          |    |        |                  |       |    |       |                  |          |    |       |                  |       |    |        |          |          |    |        |          |       |    |        |         |          |    |        |         |       |    |        |                      |          |    |        |       |          |    |        |       |       |    |        |                  |          |    |        |                  |       |    |       |       |          |    |       |       |       |    |                  |                  |          |    |                  |                  |       |    |                  |          |          |    |                  |          |       |    |                     |          |   |        |                     |          |  |        |  |
| Monel  | Monel                | Silicone                                      | 34                |  |        |          |          |    |        |          |       |    |        |                  |          |    |        |                  |       |    |       |                  |          |    |       |                  |       |    |        |          |          |    |        |          |       |    |        |         |          |    |        |         |       |    |        |                      |          |    |        |       |          |    |        |       |       |    |        |                  |          |    |        |                  |       |    |       |       |          |    |       |       |       |    |                  |                  |          |    |                  |                  |       |    |                  |          |          |    |                  |          |       |    |                     |          |   |        |                     |          |  |        |  |
| Monel  | Monel                | Inert   | 35                |  |        |          |          |    |        |          |       |    |        |                  |          |    |        |                  |       |    |       |                  |          |    |       |                  |       |    |        |          |          |    |        |          |       |    |        |         |          |    |        |         |       |    |        |                      |          |    |        |       |          |    |        |       |       |    |        |                  |          |    |        |                  |       |    |       |       |          |    |       |       |       |    |                  |                  |          |    |                  |                  |       |    |                  |          |          |    |                  |          |       |    |                     |          |   |        |                     |          |  |        |  |
| Nickel alloy (a)   | Nickel alloy (a)     | Silicone                                      | 46                |  |        |          |          |    |        |          |       |    |        |                  |          |    |        |                  |       |    |       |                  |          |    |       |                  |       |    |        |          |          |    |        |          |       |    |        |         |          |    |        |         |       |    |        |                      |          |    |        |       |          |    |        |       |       |    |        |                  |          |    |        |                  |       |    |       |       |          |    |       |       |       |    |                  |                  |          |    |                  |                  |       |    |                  |          |          |    |                  |          |       |    |                     |          |   |        |                     |          |  |        |  |
| Nickel alloy (a)   | Nickel alloy (a)     | Inert   | 47                |  |        |          |          |    |        |          |       |    |        |                  |          |    |        |                  |       |    |       |                  |          |    |       |                  |       |    |        |          |          |    |        |          |       |    |        |         |          |    |        |         |       |    |        |                      |          |    |        |       |          |    |        |       |       |    |        |                  |          |    |        |                  |       |    |       |       |          |    |       |       |       |    |                  |                  |          |    |                  |                  |       |    |                  |          |          |    |                  |          |       |    |                     |          |   |        |                     |          |  |        |  |
| Nickel alloy (a)   | Tantalum             | Silicone                                      | 48                |  |        |          |          |    |        |          |       |    |        |                  |          |    |        |                  |       |    |       |                  |          |    |       |                  |       |    |        |          |          |    |        |          |       |    |        |         |          |    |        |         |       |    |        |                      |          |    |        |       |          |    |        |       |       |    |        |                  |          |    |        |                  |       |    |       |       |          |    |       |       |       |    |                  |                  |          |    |                  |                  |       |    |                  |          |          |    |                  |          |       |    |                     |          |   |        |                     |          |  |        |  |
| Nickel alloy (a)   | Tantalum             | Inert   | 49                |  |        |          |          |    |        |          |       |    |        |                  |          |    |        |                  |       |    |       |                  |          |    |       |                  |       |    |        |          |          |    |        |          |       |    |        |         |          |    |        |         |       |    |        |                      |          |    |        |       |          |    |        |       |       |    |        |                  |          |    |        |                  |       |    |       |       |          |    |       |       |       |    |                  |                  |          |    |                  |                  |       |    |                  |          |          |    |                  |          |       |    |                     |          |   |        |                     |          |  |        |  |
| pvdF Insert (Kynar)  | Tantalum             | Silicone (Used with Process Connector Type 7) | 78 (b)            |  |        |          |          |    |        |          |       |    |        |                  |          |    |        |                  |       |    |       |                  |          |    |       |                  |       |    |        |          |          |    |        |          |       |    |        |         |          |    |        |         |       |    |        |                      |          |    |        |       |          |    |        |       |       |    |        |                  |          |    |        |                  |       |    |       |       |          |    |       |       |       |    |                  |                  |          |    |                  |                  |       |    |                  |          |          |    |                  |          |       |    |                     |          |   |        |                     |          |  |        |  |
| pvdF Insert (Kynar)  | Tantalum             | Inert (Used with Process Connector Type 7)    | 79 (b)            |  |        |          |          |    |        |          |       |    |        |                  |          |    |        |                  |       |    |       |                  |          |    |       |                  |       |    |        |          |          |    |        |          |       |    |        |         |          |    |        |         |       |    |        |                      |          |    |        |       |          |    |        |       |       |    |        |                  |          |    |        |                  |       |    |       |       |          |    |       |       |       |    |                  |                  |          |    |                  |                  |       |    |                  |          |          |    |                  |          |       |    |                     |          |   |        |                     |          |  |        |  |
| <b>2. Transmitter with Low Profile Structure LP1 (Not available with Pressure Seals)</b>   |                      |   |                   |  |        |          |          |    |        |          |       |    |        |                  |          |    |        |                  |       |    |       |                  |          |    |       |                  |       |    |        |          |          |    |        |          |       |    |        |         |          |    |        |         |       |    |        |                      |          |    |        |       |          |    |        |       |       |    |        |                  |          |    |        |                  |       |    |       |       |          |    |       |       |       |    |                  |                  |          |    |                  |                  |       |    |                  |          |          |    |                  |          |       |    |                     |          |   |        |                     |          |  |        |  |
| <table border="0"> <thead> <tr> <th data-bbox="224 1367 305 1394">Covers</th> <th data-bbox="363 1367 444 1394">Sensor</th> <th data-bbox="558 1367 656 1394">Fill Fluid</th> <th data-bbox="1321 1367 1404 1394"></th> </tr> </thead> <tbody> <tr> <td>316 ss</td> <td>316L ss</td> <td>Silicone</td> <td>LL</td> </tr> <tr> <td>316 ss</td> <td>316L ss</td> <td>Inert</td> <td>LM</td> </tr> <tr> <td>316 ss</td> <td>Nickel alloy (a)</td> <td>Silicone</td> <td>LC</td> </tr> <tr> <td>316 ss</td> <td>Nickel alloy (a)</td> <td>Inert</td> <td>LD</td> </tr> </tbody> </table>   | Covers               | Sensor  | Fill Fluid        |  | 316 ss | 316L ss  | Silicone | LL | 316 ss | 316L ss  | Inert | LM | 316 ss | Nickel alloy (a) | Silicone | LC | 316 ss | Nickel alloy (a) | Inert | LD |       |                  |          |    |       |                  |       |    |        |          |          |    |        |          |       |    |        |         |          |    |        |         |       |    |        |                      |          |    |        |       |          |    |        |       |       |    |        |                  |          |    |        |                  |       |    |       |       |          |    |       |       |       |    |                  |                  |          |    |                  |                  |       |    |                  |          |          |    |                  |          |       |    |                     |          |   |        |                     |          |  |        |  |
| Covers   | Sensor               | Fill Fluid                                    |                   |  |        |          |          |    |        |          |       |    |        |                  |          |    |        |                  |       |    |       |                  |          |    |       |                  |       |    |        |          |          |    |        |          |       |    |        |         |          |    |        |         |       |    |        |                      |          |    |        |       |          |    |        |       |       |    |        |                  |          |    |        |                  |       |    |       |       |          |    |       |       |       |    |                  |                  |          |    |                  |                  |       |    |                  |          |          |    |                  |          |       |    |                     |          |   |        |                     |          |  |        |  |
| 316 ss   | 316L ss              | Silicone                                      | LL                |  |        |          |          |    |        |          |       |    |        |                  |          |    |        |                  |       |    |       |                  |          |    |       |                  |       |    |        |          |          |    |        |          |       |    |        |         |          |    |        |         |       |    |        |                      |          |    |        |       |          |    |        |       |       |    |        |                  |          |    |        |                  |       |    |       |       |          |    |       |       |       |    |                  |                  |          |    |                  |                  |       |    |                  |          |          |    |                  |          |       |    |                     |          |   |        |                     |          |  |        |  |
| 316 ss   | 316L ss              | Inert   | LM                |  |        |          |          |    |        |          |       |    |        |                  |          |    |        |                  |       |    |       |                  |          |    |       |                  |       |    |        |          |          |    |        |          |       |    |        |         |          |    |        |         |       |    |        |                      |          |    |        |       |          |    |        |       |       |    |        |                  |          |    |        |                  |       |    |       |       |          |    |       |       |       |    |                  |                  |          |    |                  |                  |       |    |                  |          |          |    |                  |          |       |    |                     |          |   |        |                     |          |  |        |  |
| 316 ss   | Nickel alloy (a)     | Silicone                                      | LC                |  |        |          |          |    |        |          |       |    |        |                  |          |    |        |                  |       |    |       |                  |          |    |       |                  |       |    |        |          |          |    |        |          |       |    |        |         |          |    |        |         |       |    |        |                      |          |    |        |       |          |    |        |       |       |    |        |                  |          |    |        |                  |       |    |       |       |          |    |       |       |       |    |                  |                  |          |    |                  |                  |       |    |                  |          |          |    |                  |          |       |    |                     |          |   |        |                     |          |  |        |  |
| 316 ss   | Nickel alloy (a)     | Inert   | LD                |  |        |          |          |    |        |          |       |    |        |                  |          |    |        |                  |       |    |       |                  |          |    |       |                  |       |    |        |          |          |    |        |          |       |    |        |         |          |    |        |         |       |    |        |                      |          |    |        |       |          |    |        |       |       |    |        |                  |          |    |        |                  |       |    |       |       |          |    |       |       |       |    |                  |                  |          |    |                  |                  |       |    |                  |          |          |    |                  |          |       |    |                     |          |   |        |                     |          |  |        |  |
| <b>3. Transmitter with Low Profile Structure LP2 (Not available with Pressure Seals)</b>   |                      |   |                   |  |        |          |          |    |        |          |       |    |        |                  |          |    |        |                  |       |    |       |                  |          |    |       |                  |       |    |        |          |          |    |        |          |       |    |        |         |          |    |        |         |       |    |        |                      |          |    |        |       |          |    |        |       |       |    |        |                  |          |    |        |                  |       |    |       |       |          |    |       |       |       |    |                  |                  |          |    |                  |                  |       |    |                  |          |          |    |                  |          |       |    |                     |          |   |        |                     |          |  |        |  |
| <table border="0"> <thead> <tr> <th data-bbox="224 1556 305 1583">Covers</th> <th data-bbox="363 1556 444 1583">Sensor</th> <th data-bbox="558 1556 656 1583">Fill Fluid</th> <th data-bbox="1321 1556 1404 1583"></th> </tr> </thead> <tbody> <tr> <td>316 ss</td> <td>316L ss</td> <td>Silicone</td> <td>52</td> </tr> <tr> <td>316 ss</td> <td>316L ss</td> <td>Inert</td> <td>53</td> </tr> <tr> <td>316 ss</td> <td>Nickel alloy (a)</td> <td>Silicone</td> <td>56</td> </tr> <tr> <td>316 ss</td> <td>Nickel alloy (a)</td> <td>Inert</td> <td>57</td> </tr> </tbody> </table>   | Covers               | Sensor  | Fill Fluid        |  | 316 ss | 316L ss  | Silicone | 52 | 316 ss | 316L ss  | Inert | 53 | 316 ss | Nickel alloy (a) | Silicone | 56 | 316 ss | Nickel alloy (a) | Inert | 57 |       |                  |          |    |       |                  |       |    |        |          |          |    |        |          |       |    |        |         |          |    |        |         |       |    |        |                      |          |    |        |       |          |    |        |       |       |    |        |                  |          |    |        |                  |       |    |       |       |          |    |       |       |       |    |                  |                  |          |    |                  |                  |       |    |                  |          |          |    |                  |          |       |    |                     |          |   |        |                     |          |  |        |  |
| Covers   | Sensor               | Fill Fluid                                    |                   |  |        |          |          |    |        |          |       |    |        |                  |          |    |        |                  |       |    |       |                  |          |    |       |                  |       |    |        |          |          |    |        |          |       |    |        |         |          |    |        |         |       |    |        |                      |          |    |        |       |          |    |        |       |       |    |        |                  |          |    |        |                  |       |    |       |       |          |    |       |       |       |    |                  |                  |          |    |                  |                  |       |    |                  |          |          |    |                  |          |       |    |                     |          |   |        |                     |          |  |        |  |
| 316 ss   | 316L ss              | Silicone                                      | 52                |  |        |          |          |    |        |          |       |    |        |                  |          |    |        |                  |       |    |       |                  |          |    |       |                  |       |    |        |          |          |    |        |          |       |    |        |         |          |    |        |         |       |    |        |                      |          |    |        |       |          |    |        |       |       |    |        |                  |          |    |        |                  |       |    |       |       |          |    |       |       |       |    |                  |                  |          |    |                  |                  |       |    |                  |          |          |    |                  |          |       |    |                     |          |   |        |                     |          |  |        |  |
| 316 ss   | 316L ss              | Inert   | 53                |  |        |          |          |    |        |          |       |    |        |                  |          |    |        |                  |       |    |       |                  |          |    |       |                  |       |    |        |          |          |    |        |          |       |    |        |         |          |    |        |         |       |    |        |                      |          |    |        |       |          |    |        |       |       |    |        |                  |          |    |        |                  |       |    |       |       |          |    |       |       |       |    |                  |                  |          |    |                  |                  |       |    |                  |          |          |    |                  |          |       |    |                     |          |   |        |                     |          |  |        |  |
| 316 ss   | Nickel alloy (a)     | Silicone                                      | 56                |  |        |          |          |    |        |          |       |    |        |                  |          |    |        |                  |       |    |       |                  |          |    |       |                  |       |    |        |          |          |    |        |          |       |    |        |         |          |    |        |         |       |    |        |                      |          |    |        |       |          |    |        |       |       |    |        |                  |          |    |        |                  |       |    |       |       |          |    |       |       |       |    |                  |                  |          |    |                  |                  |       |    |                  |          |          |    |                  |          |       |    |                     |          |   |        |                     |          |  |        |  |
| 316 ss   | Nickel alloy (a)     | Inert   | 57                |  |        |          |          |    |        |          |       |    |        |                  |          |    |        |                  |       |    |       |                  |          |    |       |                  |       |    |        |          |          |    |        |          |       |    |        |         |          |    |        |         |       |    |        |                      |          |    |        |       |          |    |        |       |       |    |        |                  |          |    |        |                  |       |    |       |       |          |    |       |       |       |    |                  |                  |          |    |                  |                  |       |    |                  |          |          |    |                  |          |       |    |                     |          |   |        |                     |          |  |        |  |
| <b>4. Transmitter prepared for Foxboro Model Coded Remote Mount Seals (c)</b>  |                      |   |                   |  |        |          |          |    |        |          |       |    |        |                  |          |    |        |                  |       |    |       |                  |          |    |       |                  |       |    |        |          |          |    |        |          |       |    |        |         |          |    |        |         |       |    |        |                      |          |    |        |       |          |    |        |       |       |    |        |                  |          |    |        |                  |       |    |       |       |          |    |       |       |       |    |                  |                  |          |    |                  |                  |       |    |                  |          |          |    |                  |          |       |    |                     |          |   |        |                     |          |  |        |  |
| Transmitter prepared for Remote Seals on Both HI and LO Sides, Silicone Fill in Sensor   | S1 (d)               |   |                   |  |        |          |          |    |        |          |       |    |        |                  |          |    |        |                  |       |    |       |                  |          |    |       |                  |       |    |        |          |          |    |        |          |       |    |        |         |          |    |        |         |       |    |        |                      |          |    |        |       |          |    |        |       |       |    |        |                  |          |    |        |                  |       |    |       |       |          |    |       |       |       |    |                  |                  |          |    |                  |                  |       |    |                  |          |          |    |                  |          |       |    |                     |          |   |        |                     |          |  |        |  |
| Transmitter prepared for Remote Seals on Both HI and LO Sides, Inert Fill in Sensor  | S2 (d)               |   |                   |  |        |          |          |    |        |          |       |    |        |                  |          |    |        |                  |       |    |       |                  |          |    |       |                  |       |    |        |          |          |    |        |          |       |    |        |         |          |    |        |         |       |    |        |                      |          |    |        |       |          |    |        |       |       |    |        |                  |          |    |        |                  |       |    |       |       |          |    |       |       |       |    |                  |                  |          |    |                  |                  |       |    |                  |          |          |    |                  |          |       |    |                     |          |   |        |                     |          |  |        |  |
| Transmitter prepared for Remote Seal HI Side, 1/2 NPT Connector LO Side, Silicone Fill in Sensor   | S3 (d)               |   |                   |  |        |          |          |    |        |          |       |    |        |                  |          |    |        |                  |       |    |       |                  |          |    |       |                  |       |    |        |          |          |    |        |          |       |    |        |         |          |    |        |         |       |    |        |                      |          |    |        |       |          |    |        |       |       |    |        |                  |          |    |        |                  |       |    |       |       |          |    |       |       |       |    |                  |                  |          |    |                  |                  |       |    |                  |          |          |    |                  |          |       |    |                     |          |   |        |                     |          |  |        |  |
| Transmitter prepared for Remote Seal HI Side, 1/2 NPT Connector LO Side, Inert Fill in Sensor  | S4 (d)               |   |                   |  |        |          |          |    |        |          |       |    |        |                  |          |    |        |                  |       |    |       |                  |          |    |       |                  |       |    |        |          |          |    |        |          |       |    |        |         |          |    |        |         |       |    |        |                      |          |    |        |       |          |    |        |       |       |    |        |                  |          |    |        |                  |       |    |       |       |          |    |       |       |       |    |                  |                  |          |    |                  |                  |       |    |                  |          |          |    |                  |          |       |    |                     |          |   |        |                     |          |  |        |  |
| Transmitter prepared for Remote Seal LO Side, 1/2 NPT Connector HI Side, Silicone Fill in Sensor   | S5 (d)               |   |                   |  |        |          |          |    |        |          |       |    |        |                  |          |    |        |                  |       |    |       |                  |          |    |       |                  |       |    |        |          |          |    |        |          |       |    |        |         |          |    |        |         |       |    |        |                      |          |    |        |       |          |    |        |       |       |    |        |                  |          |    |        |                  |       |    |       |       |          |    |       |       |       |    |                  |                  |          |    |                  |                  |       |    |                  |          |          |    |                  |          |       |    |                     |          |   |        |                     |          |  |        |  |
| Transmitter prepared for Remote Seal LO Side, 1/2 NPT Connector HI Side, Inert Fill in Sensor  | S6 (d)               |   |                   |  |        |          |          |    |        |          |       |    |        |                  |          |    |        |                  |       |    |       |                  |          |    |       |                  |       |    |        |          |          |    |        |          |       |    |        |         |          |    |        |         |       |    |        |                      |          |    |        |       |          |    |        |       |       |    |        |                  |          |    |        |                  |       |    |       |       |          |    |       |       |       |    |                  |                  |          |    |                  |                  |       |    |                  |          |          |    |                  |          |       |    |                     |          |   |        |                     |          |  |        |  |

**MODEL CODE: IDP10 TRANSMITTER (CONTINUED)**

| Description   | Model        |              |             |  |              |            |            |  |             |              |             |       |           |            |             |       |  |  |  |   |  |
|---|--------------|--------------|-------------|--|--------------|------------|------------|--|-------------|--------------|-------------|-------|-----------|------------|-------------|-------|--|--|--|---|--|
| <b>5. Transmitter Prepared for Foxboro Model Coded Direct Connect Seals (c)</b>   |              |              |             |  |              |            |            |  |             |              |             |       |           |            |             |       |  |  |  |   |  |
| PSFLT, PSSCT, or PSSST Direct Connect Seal on HI Side; 1/2 NPT Process Connector LO Side; Silicone Fill   | F1           |              |             |  |              |            |            |  |             |              |             |       |           |            |             |       |  |  |  |   |  |
| PSFLT, PSSCT, or PSSST Direct Connect Seal on HI Side; 1/2 NPT Process Connector LO Side; Inert Fill  | F2           |              |             |  |              |            |            |  |             |              |             |       |           |            |             |       |  |  |  |   |  |
| PSFLT, PSSCT, or PSSST Direct Connect Seal on HI Side; Remote Seal with Capillary LO Side; Silicone Fill  | F3           |              |             |  |              |            |            |  |             |              |             |       |           |            |             |       |  |  |  |   |  |
| PSFLT, PSSCT, or PSSST Direct Connect Seal on HI Side; Remote Seal with Capillary LO Side; Inert Fill   | F4           |              |             |  |              |            |            |  |             |              |             |       |           |            |             |       |  |  |  |   |  |
| <b>6. Transmitter Prepared for non-Foxboro Seals</b>  |              |              |             |  |              |            |            |  |             |              |             |       |           |            |             |       |  |  |  |   |  |
| Remote Seals on High and Low Sides; Silicone Fill in Sensor   | SA           |              |             |  |              |            |            |  |             |              |             |       |           |            |             |       |  |  |  |   |  |
| Remote Seals on High and Low Sides; Inert Fill in Sensor  | SB           |              |             |  |              |            |            |  |             |              |             |       |           |            |             |       |  |  |  |   |  |
| Remote Seal on High Side and 1/2 NPT Connector on Low Side, Silicone Fill in Sensor   | SC           |              |             |  |              |            |            |  |             |              |             |       |           |            |             |       |  |  |  |   |  |
| Remote Seal on High Side and 1/2 NPT Connector on Low Side, Inert Fill in Sensor  | SD           |              |             |  |              |            |            |  |             |              |             |       |           |            |             |       |  |  |  |   |  |
| Remote Seal on Low Side and 1/2 NPT Connector on High Side, Silicone Fill in Sensor   | SE           |              |             |  |              |            |            |  |             |              |             |       |           |            |             |       |  |  |  |   |  |
| Remote Seal on Low Side and 1/2 NPT Connector on High Side, Inert Fill in Sensor  | SF           |              |             |  |              |            |            |  |             |              |             |       |           |            |             |       |  |  |  |   |  |
| <b>Span Limits</b>  |              |              |             |  |              |            |            |  |             |              |             |       |           |            |             |       |  |  |  |   |  |
| <table border="0"> <tr> <td><b>kPa</b></td> <td><b>inH2O</b></td> <td><b>mbar</b></td> <td></td> </tr> <tr> <td>0.12 and 7.5</td> <td>0.5 and 30</td> <td>1.2 and 75</td> <td></td> </tr> <tr> <td>0.87 and 50</td> <td>3.5 and 200</td> <td>8.7 and 500</td> <td>A (e)</td> </tr> <tr> <td>7 and 210</td> <td>28 and 840</td> <td>70 and 2100</td> <td>B</td> </tr> <tr> <td></td> <td></td> <td></td> <td>C</td> </tr> </table> | <b>kPa</b>   | <b>inH2O</b> | <b>mbar</b> |  | 0.12 and 7.5 | 0.5 and 30 | 1.2 and 75 |  | 0.87 and 50 | 3.5 and 200  | 8.7 and 500 | A (e) | 7 and 210 | 28 and 840 | 70 and 2100 | B     |  |  |  | C |  |
| <b>kPa</b>  | <b>inH2O</b> | <b>mbar</b>  |             |  |              |            |            |  |             |              |             |       |           |            |             |       |  |  |  |   |  |
| 0.12 and 7.5  | 0.5 and 30   | 1.2 and 75   |             |  |              |            |            |  |             |              |             |       |           |            |             |       |  |  |  |   |  |
| 0.87 and 50   | 3.5 and 200  | 8.7 and 500  | A (e)       |  |              |            |            |  |             |              |             |       |           |            |             |       |  |  |  |   |  |
| 7 and 210   | 28 and 840   | 70 and 2100  | B           |  |              |            |            |  |             |              |             |       |           |            |             |       |  |  |  |   |  |
|   |              |              | C           |  |              |            |            |  |             |              |             |       |           |            |             |       |  |  |  |   |  |
| <table border="0"> <tr> <td><b>MPa</b></td> <td><b>psi</b></td> <td><b>bar</b></td> <td></td> </tr> <tr> <td>0.07 and 2.1</td> <td>10 and 300</td> <td>0.7 and 21</td> <td></td> </tr> <tr> <td>0.7 and 21</td> <td>100 and 3000</td> <td>7 and 210</td> <td>D</td> </tr> <tr> <td></td> <td></td> <td></td> <td>E (f)</td> </tr> </table>  | <b>MPa</b>   | <b>psi</b>   | <b>bar</b>  |  | 0.07 and 2.1 | 10 and 300 | 0.7 and 21 |  | 0.7 and 21  | 100 and 3000 | 7 and 210   | D     |           |            |             | E (f) |  |  |  |   |  |
| <b>MPa</b>  | <b>psi</b>   | <b>bar</b>   |             |  |              |            |            |  |             |              |             |       |           |            |             |       |  |  |  |   |  |
| 0.07 and 2.1  | 10 and 300   | 0.7 and 21   |             |  |              |            |            |  |             |              |             |       |           |            |             |       |  |  |  |   |  |
| 0.7 and 21  | 100 and 3000 | 7 and 210    | D           |  |              |            |            |  |             |              |             |       |           |            |             |       |  |  |  |   |  |
|   |              |              | E (f)       |  |              |            |            |  |             |              |             |       |           |            |             |       |  |  |  |   |  |
| <b>Process Connector Type (Material Same as Process Cover Material) (g)</b>   |              |              |             |  |              |            |            |  |             |              |             |       |           |            |             |       |  |  |  |   |  |
| See below:  | 0            |              |             |  |              |            |            |  |             |              |             |       |           |            |             |       |  |  |  |   |  |
| ▶ For d/p: No connectors; both covers tapped for 1/4 NPT (316 ss only, no side vents)   |              |              |             |  |              |            |            |  |             |              |             |       |           |            |             |       |  |  |  |   |  |
| ▶ Flange Mount Hi Side: 1/2 NPT, 316 ss Process Connector on Lo Side (F1 and F2 only)   |              |              |             |  |              |            |            |  |             |              |             |       |           |            |             |       |  |  |  |   |  |
| ▶ Flange Mount Hi Side: No connectors; both sides prepared for seals (F3 and F4 only)   |              |              |             |  |              |            |            |  |             |              |             |       |           |            |             |       |  |  |  |   |  |
| ▶ Two Remote Seals: No connectors; both covers tapped for capillary connection (S1, S2, SA, SB only)  |              |              |             |  |              |            |            |  |             |              |             |       |           |            |             |       |  |  |  |   |  |
| ▶ One Remote Seal: 1/2 NPT, 316 ss Process Connector on Side Opposite Seal (S3 to S6, SC to SF only)  |              |              |             |  |              |            |            |  |             |              |             |       |           |            |             |       |  |  |  |   |  |
| 1/4 NPT, Not with Structure Codes 46 to 49, 78, 79, or pressure seals   | 1            |              |             |  |              |            |            |  |             |              |             |       |           |            |             |       |  |  |  |   |  |
| 1/2 NPT, Not with Structure Codes 78 or 79, or pressure seals   | 2            |              |             |  |              |            |            |  |             |              |             |       |           |            |             |       |  |  |  |   |  |
| Rc 1/4, Not with Structure Codes 46 to 49, 78, 79, or pressure seals  | 3            |              |             |  |              |            |            |  |             |              |             |       |           |            |             |       |  |  |  |   |  |
| Rc 1/2, Not with Structure Codes 78 or 79, or pressure seals  | 4            |              |             |  |              |            |            |  |             |              |             |       |           |            |             |       |  |  |  |   |  |
| 1/2 Schedule 80 Welding Neck, Not with Structure Codes 46 to 49, 78, 79, or pressure seals  | 6            |              |             |  |              |            |            |  |             |              |             |       |           |            |             |       |  |  |  |   |  |
| None; pvdf Insert tapped for 1/2 NPT/Process Inlet on Side of 316 ss Process Covers (only with 78/79 above)   | 7            |              |             |  |              |            |            |  |             |              |             |       |           |            |             |       |  |  |  |   |  |
| <b>Conduit Connection and Housing Material</b>  |              |              |             |  |              |            |            |  |             |              |             |       |           |            |             |       |  |  |  |   |  |
| 1/2 NPT Conduit Connection, Aluminum Housing  | 1            |              |             |  |              |            |            |  |             |              |             |       |           |            |             |       |  |  |  |   |  |
| PG 13.5 Conduit Connection, Aluminum Housing (With Electrical Safety Code D only)   | 2            |              |             |  |              |            |            |  |             |              |             |       |           |            |             |       |  |  |  |   |  |
| 1/2 NPT Conduit Connection, 316 ss Housing  | 3            |              |             |  |              |            |            |  |             |              |             |       |           |            |             |       |  |  |  |   |  |
| PG 13.5 Conduit Connection, 316 ss Housing (With Electrical Safety Code D only)   | 4            |              |             |  |              |            |            |  |             |              |             |       |           |            |             |       |  |  |  |   |  |
| M20 Conduit Connection, Both Sides, Aluminum Housing (With Electrical Safety Code D only)   | 5            |              |             |  |              |            |            |  |             |              |             |       |           |            |             |       |  |  |  |   |  |
| M20 Conduit Connection, Both Sides, 316 ss Housing (With Electrical Safety Code D only)   | 6            |              |             |  |              |            |            |  |             |              |             |       |           |            |             |       |  |  |  |   |  |

**MODEL CODE: IDP10 TRANSMITTER (CONTINUED)**

| Description  | Model                |
|--|----------------------|
| <p><b>Electrical Safety (Also see "ELECTRICAL SAFETY SPECIFICATIONS - IDP10 TRANSMITTERS" on page 13)</b></p>  |                      |
| <p>ATEX Flameproof; II 2 GD, EEx d IIC, Zone 1 (h)<br/>ATEX FISCO Intrinsically Safe; II 1 G, EEx ia IIC, Zone 0<br/>ATEX FNICO protection n; II 3 G, EEx nL IIC, Zone 2</p>   | <p>D<br/>E<br/>N</p> |
| <p>CSA Certifications:<br/>Division 1 explosionproof and dust-ignitionproof<br/>FISCO Division 1, Classes I, II, and III<br/>FISCO zone certified Ex ia IIC and energy limited Ex nA II<br/>FNICO Division 2, Classes I, II, and III</p> | <p>C</p>             |
| <p>CSA zone certified flameproof, Ex d IIC; also all certifications of Code C above (h)</p>  | <p>B</p>             |
| <p>FM Approvals:<br/>Division 1 explosionproof and dust-ignitionproof<br/>FISCO Division 1, Classes I, II, and III<br/>FISCO Zone approved Ex ia IIC<br/>FNICO nonincendive Division 2, Classes I, II, and III</p>                       | <p>F</p>             |
| <p>FM approved flameproof, AEx d IIC; also all approvals of Code F above (h)</p>   | <p>G</p>             |
| <p>IECEX FISCO intrinsically safe, Ex ia IIC, Zone 0<br/>IECEX flameproof; Ex d IIC, Zone 1 (h)<br/>IECEX FNICO protection n, Ex nL IIC, Zone 2</p>  | <p>T<br/>V<br/>U</p> |
| <p><b>Optional Selections</b></p>  |                      |
| <p><b>Mounting Bracket Set (i)</b></p>   |                      |
| <p>Standard Style Painted Steel Bracket with Plated Steel Bolts</p>  | <p>-M1</p>           |
| <p>Standard Style Stainless Steel Bracket with Stainless Steel Bolts</p>   | <p>-M2</p>           |
| <p>Universal Style Stainless Steel Bracket with Stainless Steel Bolts<br/>(Not with Structure Codes LL, LM, LC, or LD)</p>   | <p>-M3</p>           |
| <p><b>Digital Indicator with Pushbuttons</b></p>   |                      |
| <p>Digital Indicator, Pushbuttons, and Window Cover</p>  | <p>-L1</p>           |
| <p><b>DIN 19213 Construction used with Process Connector Code 0 and 316 ss Covers with no side vents (j)</b></p>   |                      |
| <p>Single Ended Process Cover with M10, B7 Steel Bolting (k) (l)</p>   | <p>-D1</p>           |
| <p>Double Ended Process Cover with M10, B7 Steel Bolting; Blind Kidney Flange on Back (k) (m) (n)</p>  | <p>-D2</p>           |
| <p>Single Ended Process Cover with 7/16 in, B7 Steel Bolting; Standard Rating 25 MPa (3626 psi) (l)</p>  | <p>-D3</p>           |
| <p>Double Ended Process Cover with 7/16 in, B7 Steel Bolting; Blind Kidney Flange on Back (k) (m) (n)</p>  | <p>-D4</p>           |
| <p>Single Ended Process Cover with 7/16 in, 316 ss Bolting (k) (l)</p>   | <p>-D5</p>           |
| <p>Double Ended Process Cover with 7/16 in, 316 ss Bolting; Blind Kidney Flange on Back (k) (m) (n)</p>  | <p>-D6</p>           |
| <p>Single Ended Process Cover with 7/16 in, 17-4 ss Bolting; Standard Rating 25 MPa (3626 psi) (l)</p>   | <p>-D7</p>           |
| <p>Double Ended Process Cover with 7/16 in, 17-4 ss Bolting; Blind Kidney Flange on Back (k) (m) (n)</p>   | <p>-D8</p>           |
| <p>Single Ended Process Cover with 7/16 in, 17-4 ss Bolting; Rated 400 bar, 5800 psi, 40 MPa (l)<br/>Not available with Span Codes A, D, or E; or Option Codes -V, -B1, -B2, -B3, or -Y</p>  | <p>-D9</p>           |

**MODEL CODE: IDP10 TRANSMITTER (CONTINUED)**

| Description   | Model |
|---|-------|
| <b><u>Cleaning and Preparation - Not Available with Gold-Plated Sensor, Structure 2G (j)</u></b>  |       |
| Unit Degreased - for Silicone Filled Sensors Only<br>(Not for Oxygen/Chlorine/Other Fluids that may react with Silicone)                                  | -X1   |
| Cleaned and Prepared for Oxygen Service - for Inert Filled Sensors Only<br>(Not Available with Carbon Steel Covers or with Silicone Filled Sensors)       | -X2   |
| Cleaned and Prepared for Chlorine Service - for Inert Filled Sensors Only (o)<br>(Not Available with Carbon Steel Covers or with Silicone Filled Sensors) | -X3   |
| <b><u>Bolting for Process Covers/Connectors - Not with DIN 19213 Construction or Structure Codes 78 and 79 (p)</u></b>                                    |       |
| 316 ss Bolts and Nuts (Pressure Derated; Not Available with -Y Option) (k)  | -B1   |
| 17-4 ss Bolts and Nuts (o)  | -B2   |
| B7-M Bolts and Nuts (NACE) (k)  | -B3   |
| <b><u>Conduit Thread Adapters (Not available with Conduit Connection Codes 5 and 6)</u></b>   |       |
| Hawke-Type 1/2 NPT Cable Gland for use with Conduit Connection Codes 1 and 3 (q)  | -A1   |
| M20 Conduit Thread Adapter for use with Conduit Connection Codes 1 and 3 (q)  | -A3   |
| <b><u>Electronics Housing Features</u></b>  |       |
| External Zero Adjustment  | -Z1   |
| Custody Transfer Lock and Seal  | -Z2   |
| External Zero Adjustment and Custody Transfer Lock/Seal   | -Z3   |
| <b><u>Custom Factory Configuration</u></b>  |       |
| Full Factory Configuration (Requires Configuration Form to be Filled Out)   | -C2   |
| <b><u>Tubing Connectors - Not available with Structure Codes 78 and 79 (j)</u></b>  |       |
| Steel, Connecting 6 mm Tubing to 1/4 NPT Process Connector  | -E1   |
| Only with Structure Codes 10 to 13; and Process Connector Codes 0 and 1   |       |
| Steel, Connecting 12 mm Tubing to 1/2 NPT Process Connector   | -E2   |
| Only with Structure Codes 10 to 13; and Process Connector Code 2  |       |
| 316 ss, Connecting 6 mm Tubing to 1/4 NPT Process Connector   | -E3   |
| Only with Structure Codes 10 to 13 and 20 to 23; and Process Connector Codes 0 and 1  |       |
| 316 ss, Connecting 12 mm Tubing to 1/2 NPT Process Connector  | -E4   |
| Only with Structure Codes 10 to 13 and 20 to 23; and Process Connector Code 2   |       |
| <b><u>Vent Screw in Process Cover</u></b>   |       |
| Supply Vent Screw in Side of Each Process Cover   | -V    |
| (Available only on Traditional Process Cover Structure Codes 22 to 47)  |       |
| Omit Vent Screw in Side of Each Process Cover   | -V1   |
| (Available only on Type LP1 Low Profile Process Cover Structures Codes LL, LM, LC, and LD)  |       |
| <b><u>Adapters for Direct Mount to Competitive Manifolds (See inside pages for manifold compatibility) (r)</u></b>  |       |
| See inside pages for manifold compatibility.  |       |
| Adapter Set for MC Coplanar Manifolds, B7 Bolts (not with options -B1, -B2, or -B3)   | -P1   |
| Adapter Set for MC Coplanar Manifolds, 316 ss Bolts (requires -B1 option)   | -P2   |
| Adapter Set for MC Coplanar Manifolds, 17-4 ss Bolts (requires -B2 option)  | -P3   |
| Adapter Set for MC Coplanar Manifolds, B7M Bolts (requires -B3 option)  | -P4   |
| Adapter Set for MT3 Coplanar Manifolds, Traditional Flange, B7 Bolts (not with options -B1, -B2, or -B3)  | -P5   |
| Adapter Set for MT3 Coplanar Manifolds, Traditional Flange, 316 ss Bolts (requires -B1 option)  | -P6   |
| Adapter Set for MT3 Coplanar Manifolds, Traditional Flange, 17-4 ss Bolts (requires -B2 option)   | -P7   |
| Adapter Set for MT3 Coplanar Manifolds, Traditional Flange, B7M Bolts (requires -B3 option)   | -P8   |

MODEL CODE: IDP10 TRANSMITTER (CONTINUED)

| Description  | Model |
|--|-------|
| <b>Gaskets</b>   |       |
| Gasket for Vacuum Service with Pressure Seals (s)  | -G1   |
| <b>Instruction Books (Common MI, Brochure, and Full Documentation Set on DVD is Standard)</b>  |       |
| Without Instruction Book and DVD; only "Getting Started" brochure is supplied.   | -K1   |
| <b>Miscellaneous Optional Selections</b>   |       |
| Low Temperature Operative Limit of Electronics Housing Extended Down to -50°C (-58°F) (t)<br>Not available with sensors and seals with Inert fill; Structure Codes 78 and 79; and DIN Options -D2, -D4, -D6, and -D8 | -J    |
| Supplemental Customer Tag (Stainless Steel Tag wired onto Transmitter)   | -T    |
| Static Pressure Rating to 40 MPa (5800 psi); Only with Span Codes B and C<br>Not available with:   | -Y    |
| <ul style="list-style-type: none"> <li>▶ – Options -B1, -B2, and -B3 (u)</li> <li>▶ – Options -D1 to -D9</li> <li>▶ – Structure Codes 34, 35, 78, 79, S1 to S6, SA to SF, F1 to F4</li> </ul>                        |       |

- a. Equivalent to Hastelloy® C.
- b. Maximum static pressure rating is 2.1 MPa (300 psi); temperature limits are -7 and +82°C (20 and 180°F).
- c. Both Transmitter and Pressure Seal Model Numbers are required. See PSS 2A-1Z11 A for the various pressure seal Model Codes.
- d. Remote Seal Models that may be specified are PSFPS, PSFES, PSFAR, PSTAR, PSISR, PSSCR, and PSSSR.
- e. Span Limit Code A is not available with pressure seals, except for Sanitary Spud Seals Models PSSSR-.4 and PSSST-.4.
- f. Span Limit Code E is not available with Structure Codes 78 and 79 above (pvd insert in HI side cover).
- g. Select Code "0" if a pressure seal is specified. Otherwise select Code 1 through 7.
- h. Cover locks are provided as standard with Electrical Safety Codes D, B, G, and V.
- i. Mounting sets not offered with direct connect (flange mount) seals.
- j. Not available when Remote Mount or Direct Connect (Flanged Level) Seals are specified.
- k. See Functional Specifications section for pressure deratings when some DIN 19213 options and Bolting Options -B1/-B3 are specified.
- l. Not available with Low Profile Structure Codes 52 to 67. Temperature limits derated to 0 and 60°C (32 and 140°F). Also not available with Structure Codes 52 to 57, and LL, LM, LC, or LD.
- m. Temperature limits derated to 0 to 60°C (32 to 140°F). Also not available with Structure Codes 52 to 57 and LL, LM, LC, or LD.
- n. Mounting Bracket Set options are not available.
- o. When -X3 is specified, the standard bolting is replaced with 17-4 ss bolts and nuts. Therefore, there is no need to specify Option -B2 when selecting the Chlorine Service Option -X3.
- p. Not available with DIN construction options. For stainless steel bolts with DIN construction, specify -D5 to -D9, as required.
- q. Available with Electric Safety Code D only.
- r. Adapter plate options -P1 to -P8 are not available with:
  - Pressure Seal Structure Codes.
  - Process Connector Codes 1-7.
  - DIN Construction Options -D1, -D2, -D4, -D5, -D6, -D7, -D8, -D9.
- s. -G1 is a required option when pressure seal will be used in vacuum applications. This option substitutes vacuum service metal gasket for standard ptfе process cover gasket.
- t. -50°C indicates sensor and electronics ambient temperature capabilities. Performance is not assured below -29°C. Sensor damage may occur if process is frozen.
- u. -B2 Bolt Option (17-4 ss) is not available with the -Y option because 17-4 ss bolts and nuts are supplied as part of the -Y option.



### SUGGESTED RFQ SPECIFICATIONS

The manufacturer shall provide absolute, gauge, or d/p Cell Transmitters (with or without pressure seals) featuring FISCO/FNICO compliant FOUNDATION Fieldbus Communication Protocol, and transmitting a digital output signal, for use in a standard two-wire dc supply voltage system. Typical specifications for this family of transmitters are as follows:

|                                      |  |
|--------------------------------------|--|
| <b>Communication Protocol:</b>       | FOUNDATION Fieldbus, 31.25 bits/s; FISCO/FNICO compliant   |
| <b>Span Limits:</b>                  | <p>d/p Cell Transmitters:<br/>0.5 inH<sub>2</sub>O to 3000 psi, using five sensors</p> <p>Bracket Mounted Absolute Pressure Transmitters:<br/>3.5 inH<sub>2</sub>O to 3000 psi using four sensors</p> <p>Bracket Mounted Gauge Pressure Transmitters:<br/>0.5 inH<sub>2</sub>O to 5000 psi using six sensors</p> <p>Direct Connected Gauge Pressure Transmitters:<br/>1 to 6000 psi, using four sensors</p> <p>Direct Connected Absolute Pressure Transmitters:<br/>1 to 3000 psi, using three sensors</p>   |
| <b>Accuracy:</b>                     | ±0.05% of calibrated span for linear output  |
| <b>LCD Indicator:</b>                | Optional Liquid Crystal Display (LCD) Indicator with pushbuttons for on-board calibration and configuration  |
| <b>Damping:</b>                      | Settable for a range of none to 32 seconds   |
| <b>Electronics Housing:</b>          | Epoxy coated aluminum or 316 ss, IEC IP66 (NEMA 4X), two-compartment housing with one for field wiring and the other for the electronics   |
| <b>Modular Electronics:</b>          | Easily replaceable, modular electronics  |
| <b>RFI Protection:</b>               | Maximum error shall be no more than an additional ±0.1% of calibrated span for 30 V/m field intensity between 27 and 1000 MHz  |
| <b>Process Cover Materials:</b>      | Industry Standard 316 ss, Carbon Steel, Monel, or nickel alloy (a). Sensor process wetted diaphragms in a vertical plane for IAP20 and IGP20 Transmitter. depending on transmitter structure selected  |
| <b>Sensor Materials:</b>             | 316L ss, Co-Ni-Cr, Monel, nickel alloy (a), Tantalum, or 316L ss Gold-Plated sensors, depending on transmitter structure selected  |
| <b>Process Connection:</b>           | <p>IAP10/IGP10 Transmitters: Direct to process piping or pressure seal with 1/2 NPT; optional Rc 1/2 or G 1/2 B external threads to process piping.<br/>Internal 1/4 NPT thread also provided as plumbing connection to the process; or prepared for a direct connect seal, or remote capillary connected seal.</p> <p>IAP20/IGP20/IDP10 Transmitters: Used with process connectors to accept 1/4 NPT, 1/2 NPT, Rc 1/4, Rc 1/2, Schedule 80 welding neck; or pvdf insert(s) (tapped for 1/2 NPT) in process cover(s) is(are) used as process connection.<br/>Connection can also be prepared to accept a direct connect seal; or prepared for a single remote capillary connected seal, or two remote capillary connected seals.<br/>IDP10 available with traditional or low profile structures (low profile structures not available with seals).</p> |
| <b>Approvals and Certifications:</b> | Suitable for Division 1 locations, and conform to all applicable European Union Directives. FISCO/FNICO approvals and certifications. Versions available to meet Agency flameproof and zone requirements.  |

**Approximate Mass:**

1.5 kg (3.3 lb) for Direct-connected AP and GP Transmitters  
3.5 kg (7.8 lb) for Bracket Mounted AP and GP Transmitters  
4.2 kg (9.2 lb) for DP Transmitters with Process Connectors  
See inside pages for IDP10 traditional and low profile structures.  
With 316 ss Housing: Add 1.1 kg (2.4 lb)  
With LCD Indicator: Add 0.2 kg (0.4 lb)  
With Pressure Seals: See PSS 2A-1Z11 A

**Model Codes:**

I/A Series IAP10/IGP10 Direct-connected Absolute/Gauge Pressure Transmitters;  
IAP20/IGP20 Bracket Mounted Absolute/Gauge Pressure Transmitters, or IDP10 d/p  
Cell Transmitters; with FOUNDATION Fieldbus Communication Protocol; with or without  
pressure seals; or equivalent.

- a. Equivalent to Hastelloy® C.

DIMENSIONS - NOMINAL

IAP10 AND IGP10 DIRECT CONNECTED TRANSMITTERS

mm  
in

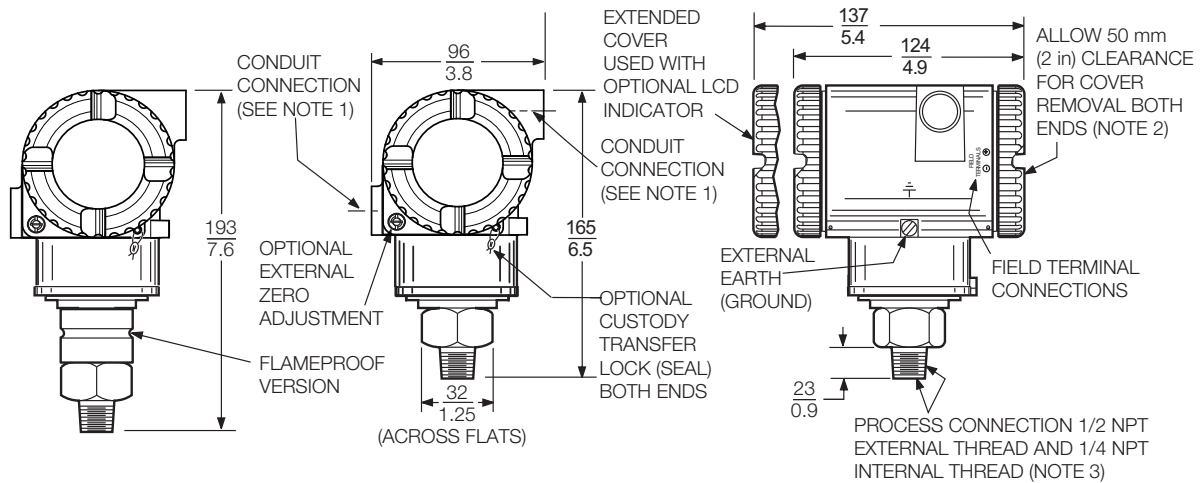

IAP20 AND IGP20 BRACKET MOUNTED TRANSMITTERS

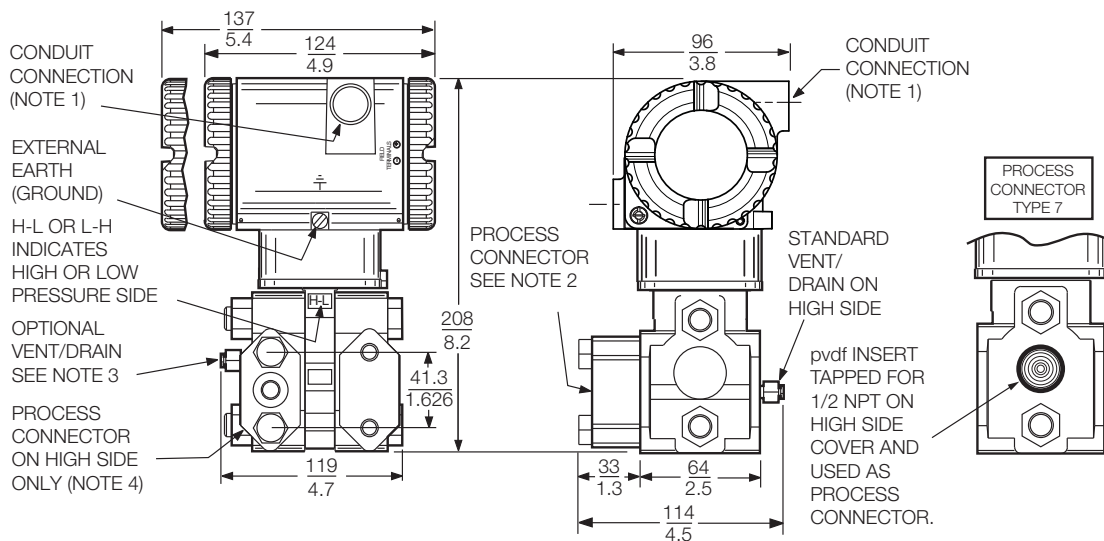

NOTES

1. CONDUIT CONNECTION 1/2 NPT, PG 13.5, OR M20, BOTH SIDES : PLUG UNUSED CONNECTION WITH METAL PLUG (SUPPLIED).
2. PROCESS CONNECTOR CAN BE REMOVED AND CONNECTION MADE DIRECTLY TO PROCESS COVER USING 1/4 NPT INTERNAL THREAD IN PROCESS COVER. NOTE THAT WITH PROCESS CONNECTION CODE "0", THERE IS NO CONNECTOR.
3. PROCESS COVER CAN BE INVERTED MAKING OPTIONAL SIDE VENT A SIDE DRAIN.
4. FOR USERS WHO DESIRE THE PROCESS CONNECTOR ON THE RIGHT SIDE, MERELY ROTATE TRANSMITTER 180° AND RELOCATE PROCESS CONNECTOR SHOWN TO THE RIGHT SIDE.
5. TOPWORKS ROTATABLE TO ANY POSITION WITHIN ONE TURN COUNTERCLOCKWISE OF FULLY TIGHTENED POSITION.
6. DO NOT USE THE 1/4 NPT INTERNAL THREAD TO DIRECT-CONNECT THE TRANSMITTER.

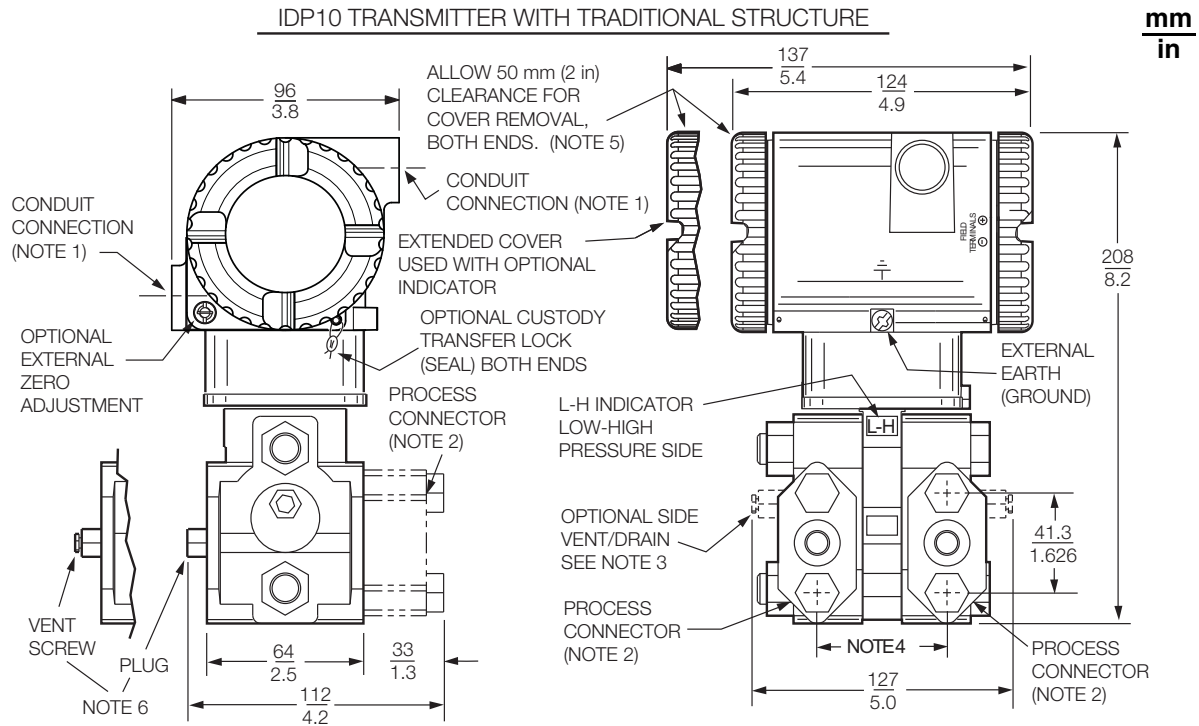

**NOTES:**

1. CONDUIT CONNECTION 1/2 NPT, PG 13.5, OR M20, BOTH SIDES: PLUG UNUSED CONNECTION WITH METAL PLUG (SUPPLIED).
2. PROCESS CONNECTORS MAY BE REMOVED AND TRANSMITTER MOUNTED DIRECTLY ON A MANIFOLD, OR CONNECTIONS MADE DIRECTLY TO PROCESS COVER USING 1/4 NPT INTERNAL THREAD IN PROCESS COVER.
3. PROCESS COVER CAN BE INVERTED MAKING OPTIONAL SIDE VENTS OR SIDE DRAINS
4. PROCESS CONNECTORS CAN BE INVERTED TO GIVE EITHER 51, 54, OR 57 mm (2.0, 2.125, OR 2.25 in) CENTER-TO-CENTER DISTANCE BETWEEN HIGH AND LOW PRESSURE CONNECTIONS.
5. TOPWORKS CAN BE ROTATED TO ANY POSITION WITHIN ONE TURN COUNTERCLOCKWISE OF THE FULLY TIGHTENED POSITION.
6. PROCESS COVER END PLUGS ARE SUBSTITUTED FOR VENT SCREWS WHEN OPTIONAL SIDE VENTS (NOTE 3) ARE SPECIFIED.

**PROCESS CONNECTOR TYPE 7 AND DIN CONSTRUCTION OPTIONS**

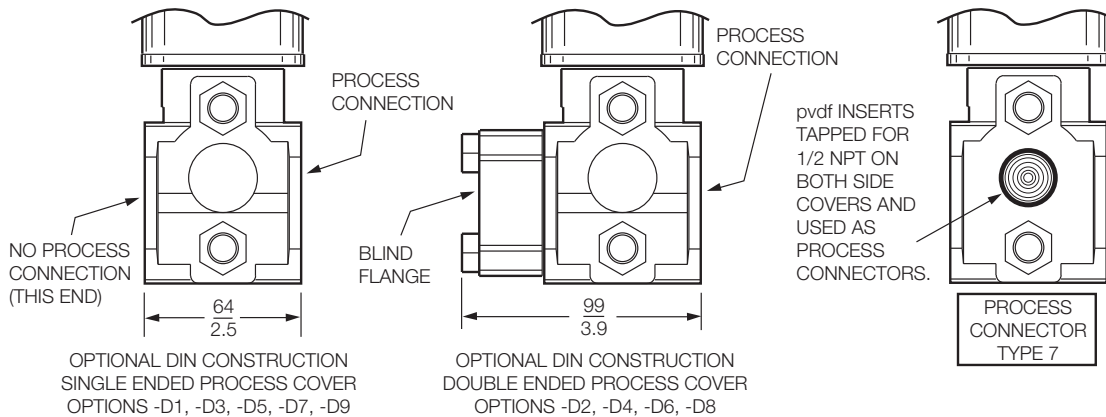

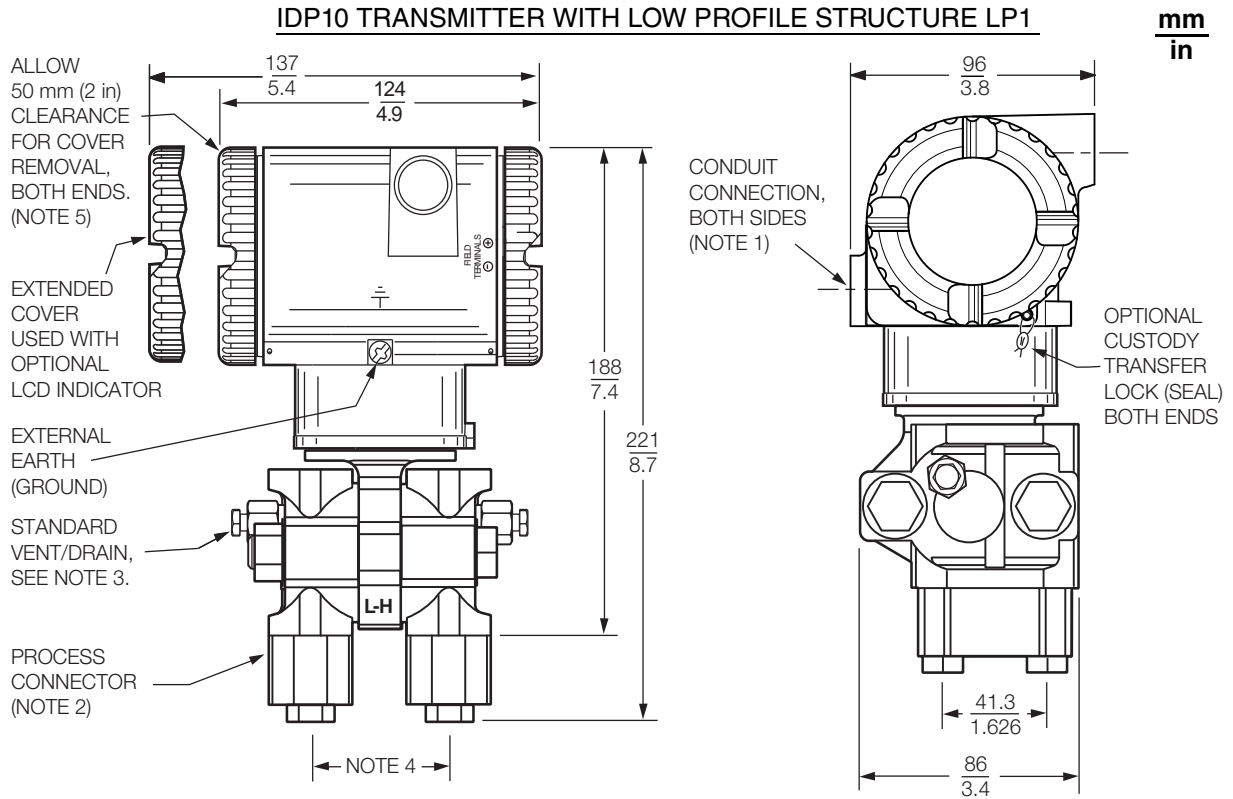

NOTES:

1. CONDUIT CONNECTION 1/2 NPT, PG 13.5, OR M20, BOTH SIDES: PLUG UNUSED CONNECTION WITH METAL PLUG (SUPPLIED).
2. PROCESS CONNECTORS MAY BE REMOVED AND TRANSMITTER MOUNTED DIRECTLY ON A MANIFOLD, OR CONNECTIONS MADE DIRECTLY TO PROCESS COVER USING 1/4 NPT INTERNAL THREAD IN PROCESS COVER.
3. THE TRANSMITTER'S LOW PROFILE STRUCTURE LP1 IS SHOWN IN THE VERTICALLY UPRIGHT POSITION. NOTE THE LOCATION OF THE STANDARD VENT/DRAIN SCREW. IN THIS CONFIGURATION THE TRANSMITTER CAN BE VENTED OR IS SELF-DRAINING. ALSO RECOMMENDED IS A HORIZONTAL INSTALLATION WHERE THE INSTALLED ORIENTATION CAN BE SET TO ALLOW FOR VENTING OR DRAINING.
4. PROCESS CONNECTORS CAN BE INVERTED TO GIVE EITHER 51, 54, OR 57 mm (2.0, 2.125, OR 2.25 in) CENTER-TO-CENTER DISTANCE BETWEEN HIGH AND LOW PRESSURE CONNECTIONS.
5. TOPWORKS CAN BE ROTATED TO ANY POSITION WITHIN ONE TURN COUNTERCLOCKWISE OF THE FULLY TIGHTENED POSITION.

IDP10 TRANSMITTER WITH LOW PROFILE STRUCTURE LP2

mm  
in

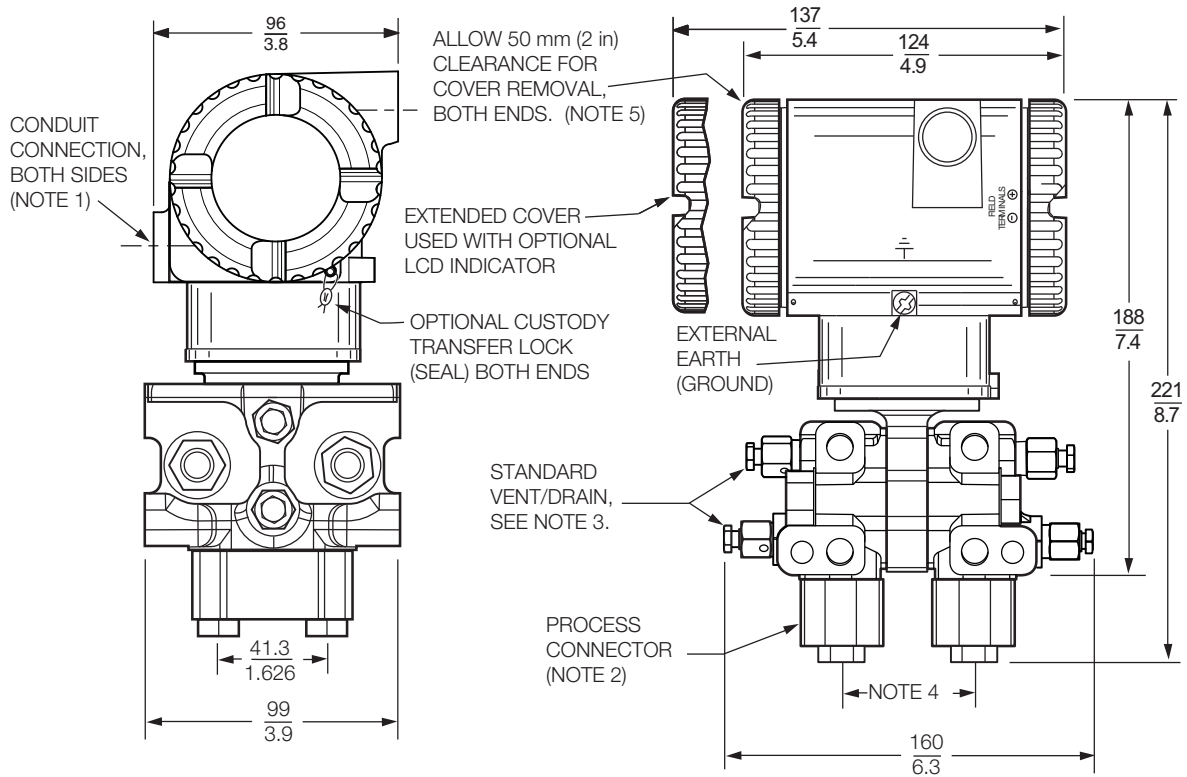

NOTES:

1. CONDUIT CONNECTION 1/2 NPT, PG 13.5, OR M20, BOTH SIDES: PLUG UNUSED CONNECTION WITH METAL PLUG (SUPPLIED).
2. PROCESS CONNECTORS MAY BE REMOVED AND TRANSMITTER MOUNTED DIRECTLY ON A MANIFOLD, OR CONNECTIONS MADE DIRECTLY TO PROCESS COVER USING 1/4 NPT INTERNAL THREAD IN PROCESS COVER.
3. THE TRANSMITTER'S LOW PROFILE STRUCTURE LP2 IS SHOWN IN THE RECOMMENDED VERTICAL UPRIGHT POSITION. NOTE THE STANDARD VENT OR DRAIN SCREWS. HORIZONTAL INSTALLATIONS ARE NOT RECOMMENDED.
4. PROCESS CONNECTORS CAN BE INVERTED TO GIVE EITHER 51, 54, OR 57 mm (2.0, 2.125, OR 2.25 in) CENTER-TO-CENTER DISTANCE BETWEEN HIGH AND LOW PRESSURE CONNECTIONS.
5. TOPWORKS CAN BE ROTATED TO ANY POSITION WITHIN ONE TURN COUNTERCLOCKWISE OF THE FULLY TIGHTENED POSITION.

IAP10/IGP10 WITH OPTIONS -M1 TO -M6

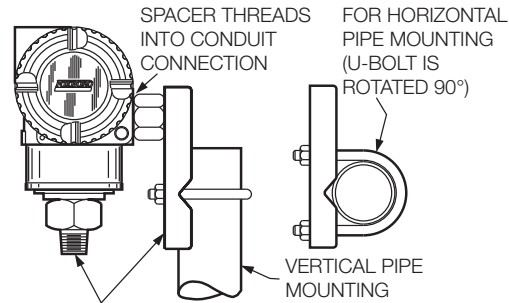

mm  
in

IAP20/IGP20/IDP10 WITH  
OPTIONS -M1, -M2, AND -M3

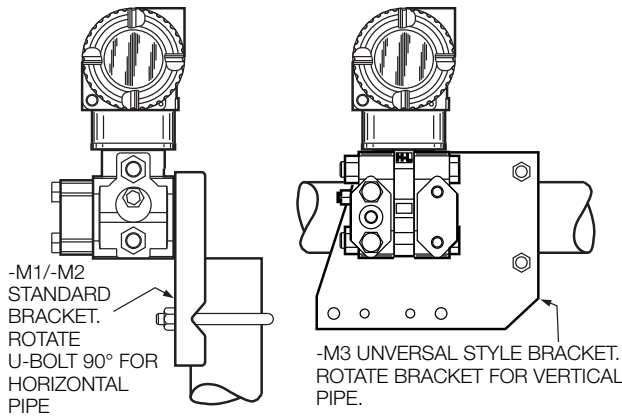

IAP20/IGP20/IDP10 WITH OPTIONS  
-D1, -D3, -D5, -D7, -D9      -D2, -D4, -D6, -D8

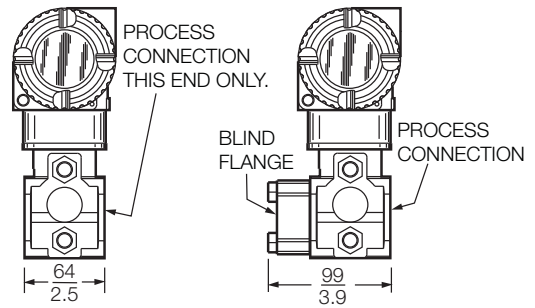

IAP10/IGP10  
OPTION -V1

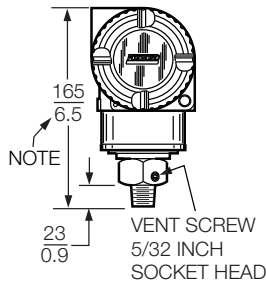

IAP10/IGP10  
OPTION -G

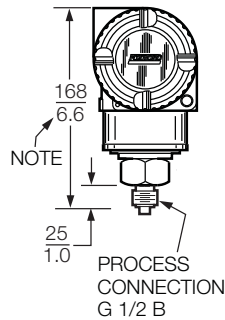

IAP10/IGP10  
OPTION -R

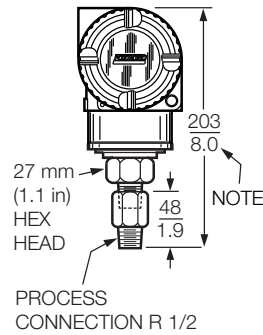

IAP10/IGP10  
-V2, -V3, -V4

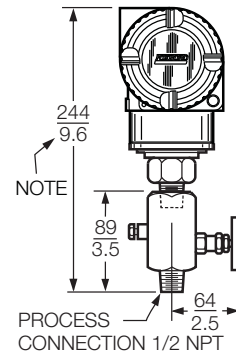

NOTES

1. FOR FLAMEPROOF TRANSMITTERS, ADD 28 mm (1.1 in) TO OVERALL HEIGHT DIMENSION.
2. REFER TO DIMENSIONAL PRINT DP 020-447 (AP AND GP) AND DP 020-446 (DP) FOR FURTHER INFORMATION.



### ORDERING INSTRUCTIONS

1. Model Number(s) as follows:
  - Transmitter only if pressure seals are not selected
  - Both transmitter and pressure seal if pressure seal is selected.  
See PSS 2A-1Z11 A.
2. Calibrated Pressure Range (using Allowable Pressure Units from the table below).

|                    |      |      |                   |                    |
|--------------------|------|------|-------------------|--------------------|
| inH <sub>2</sub> O | inHg | kPa  | mbar              | kg/cm <sup>2</sup> |
| ftH <sub>2</sub> O | mmHg | MPa  | bar               | psi                |
| mmH <sub>2</sub> O | Pa   | torr | g/cm <sup>2</sup> | atm                |

3. Configuration Data Form when Factory Calibration Option -C2 is specified.
4. Options and Accessories not in Model Code (see PSS 2A-1Z9 E).
5. User Tag Data – Data Plate; 32 characters maximum. For additional tag data, specify Optional Supplemental Tag -T.
6. User Tag Data – Software (Database); 32 characters maximum (user configured).

### OTHER FOXBORO PRODUCTS

The Foxboro product lines offer a broad range of measurement and instrument products, including solutions for pressure, flow, analytical, temperature, positioning, controlling, and recording. For a list of these offerings, visit our web site at:

[www.fielddevices.foxboro.com](http://www.fielddevices.foxboro.com)