

**Model CO Compact Orifice
for use with
Foxboro[®] Differential Pressure Transmitters**



**MODEL CO
WITH TRADITIONAL
STRUCTURE**



**MODEL CO
WITH LOW PROFILE
STRUCTURE (LP1)**



**MODEL CO
WITH LOW PROFILE
STRUCTURE (LP2)**

The Model CO Compact Orifice is a wafer body orifice plate that includes an integral three-valve manifold. This rugged, one-piece unit mounts directly to an I/A Series[®] differential pressure transmitter. An alignment ring and an optional installation kit provide the hardware necessary to properly install the orifice in various pipeline sizes having ANSI or DIN flanges.

FEATURES

- ▶ Direct mounting of the Model CO Compact Orifice to d/p Cell[®] transmitter, as compared to separate and remote manifold and transmitter installations, provides improved and more consistent performance and a greatly simplified and economical installation procedure.
- ▶ The Compact Orifice and the calibrated transmitter are factory assembled to form a functioning unit, and shipped ready for installation in a pipeline.
- ▶ Suitable for use in liquid, gas, or steam service.
- ▶ Optimal beta ratios of 0.40 or 0.65 available.
- ▶ A 316 ss, 25 mm (1 in) thick wafer body, with a concentric orifice.
- ▶ Offered for use in pipeline sizes ranging from DN 15 to DN 100, or 1/2 to 4 inches, having ANSI or DIN flanges.
- ▶ A standard alignment ring, for use with the pipeline size and ANSI or DIN flange selected, is provided with each Model CO to easily and accurately center the orifice within the pipeline.
- ▶ Ready-to-Install assembly.
- ▶ Pipeline installation kits (with studs, nuts, and gaskets), consistent with pipeline size and flange type, are optionally available.

FlowExpertPro™

FlowExpertPro is a program primarily used to size Foxboro flow devices such as flowmeters and orifices. It also ensures that the user has selected the proper flow device for his application. The flow device selection tool is provided as a free web site to all users, without the need for registration. In addition to flow device (compact orifice) selection and sizing, FlowExpertPro includes the following features:

- ▶ Incorporates a large library of the physical properties of typical process fluids.
- ▶ Displays results in tabular or graphic format.
- ▶ Allows user to save, print, or E-mail results.
- ▶ Provides reference to applicable flowmeter PSSs and other related flowmeter documentation.

The program calculates minimum and maximum flow rates, rangeability, pressure loss, and Reynolds Number, using established flow equations. It also allows for material and flange selection. You are invited to visit www.FlowExpertPro.com to access this program, or contact Global Customer Support for further information and technical support.

SIZES AND CONFIGURATIONS AVAILABLE FOR MOST GENERAL PURPOSE APPLICATIONS

The compact orifice can be installed in pipelines having 1/2 to 4 in ANSI Class 150, 300, or 600 flanges, or DN 15 to 100 PN 16, PN 40, or PN 100 flanges. This is consistent with most general purpose requirements where gas, liquid, or steam flow is to be measured.

Beta ratios (β) of 0.40 or 0.65 may be selected which are optimal betas for most concentric orifice flow applications.

DIRECT MOUNTING OF COMPACT ORIFICE TO TRANSMITTER

When compared to a conventional orifice plate with a separate manifold and remote transmitter, the Model CO Compact Orifice:

- ▶ Provides more accurate and repeatable performance.
- ▶ Eliminates numerous parts and field connections.
- ▶ Eliminates impulse lines, flange taps, and potential leak points.
- ▶ Improves response time.
- ▶ Reduces field assembly and installation costs.
- ▶ Is delivered factory assembled to a calibrated transmitter and ready for installation.
- ▶ Allows precise orifice plate centering by using the standard alignment ring provided with each unit.
- ▶ Reduces parts inventory.

READY-TO-INSTALL ASSEMBLY

The compact orifice with a d/p Cell Transmitter is a ready-to-install package of primary element, manifold, and transmitter.

ALIGNMENT RINGS AND HARDWARE KIT PROVIDED FOR PROPER INSTALLATION

Centering of the compact orifice within the pipeline is necessary to reduce flow errors and improve overall measurement performance. Therefore, to ensure proper installation, an alignment ring is provided that is consistent with the pipeline size and whether ANSI or DIN flanges are used. For users who require flange bolting hardware for use with the alignment ring, an optional installation kit (studs, nuts, and gaskets) can be provided consistent with pipeline size and flange type ANSI or DIN selected.

USED WITH FOXBORO TRANSMITTERS

The compact orifice is used with the following I/A Series d/p Cell transmitters listed below.

Model	Description (a)	Protocol	PSS No.
IDP10	DP	FoxCom™	2A-1C14 A
IDP10	DP	HART	2A-1C14 B
IDP10	DP	Fieldbus (b)	2A-1C13 E
IDP10	DP	Analog (c)	2A-1C14 C
IDP10	DP	Analog (d)	2A-1C13 D
IDP25	Multirange (DP)	FoxCom, HART, and Fieldbus	2A-1C14 K
IDP50	Premium Performance (DP)	FoxCom, HART, and Fieldbus	2A-1C14 L
IMV25	Multivariable (DP, AP, and T)	FoxCom, HART, and Fieldbus	2A-1C15 B
IMV30	Multivariable (DP, AP, and T)	FoxCom and HART	2A-1C15 A

(a) DP = Diff. Pressure; AP = Absolute Pressure; T = Temperature.

(b) Fieldbus = FOUNDATION Fieldbus.

(c) Analog = 4 to 20 mA dc analog output.

(d) Analog = 1 to 5 V dc (Low Power)

STANDARD SPECIFICATIONS

Orifice Type

Concentric, square edge, corner tap

Process Fluids

Liquid, gas, and steam

Process Temperature Limits

-40 to +232°C (-40 to +450°F)

Maximum Working Pressure

Per ANSI Class 600 or DIN PN 100 flanges

Flow (Discharge) Coefficient Uncertainty

15 TO 40 mm (1/2 TO 1 1/2 in) LINE SIZES

1.75% Uncertainty

50 TO 100 mm (2 TO 4 in) LINE SIZES

1.25% Uncertainty

Pipeline Sizes

DN 15, DN 25, DN 50, DN 80, or DN 100;
1/2, 1, 1 1/2, 2, 3, or 4 in

Beta Ratio (β)

0.40 or 0.65

Process Connections

Mounts between ANSI Class 150, 300, or 600 flanges, or DIN PN 16, PN 40, or PN 100 flanges.

Assembly to Transmitter

Delivered assembled to a calibrated Foxboro IDP10, IDP25 or IDP50 d/p Cell Transmitter, or an IMV25 or IMV30 Multivariable Transmitter.

Body and Gasket Materials - Process Wetted

COMPACT ORIFICE

316 ss with ptfe gaskets

OPTIONAL FLANGE GASKETS

Durlon 8500 Aramid/Inorganic Fiber
with NBR rubber binder

Stud and Nut Material - Not Process Wetted

COMPACT ORIFICE-TO-TRANSMITTER

316 ss Studs, A193 Gr. B8M
316 ss Nuts, A194 Gr. 8M

OPTIONAL FLANGE BOLTING

Plated Carbon Steel Studs and Nuts

Recommended Mounting Arrangements

Flow Direction	Liquid	Gas	Steam
Horizontal	YES (a)	YES (b)	YES (a)
Vertical - Flow Up	YES	YES	NO
Vertical - Flow Down	NO	YES	NO

- (a) Housing should be mounted below pipeline to ensure that gases do not collect on transmitter sensing diaphragms.
- (b) Housing should be mounted above pipeline to ensure that condensate does not collect on transmitter sensing diaphragms.

Bore Size

The orifice bore size varies with the pipe size used and the nominal beta ratio selected (0.40 or 0.65). The beta ratio is defined as d/D , where d is the bore size and D is the I.D. of the pipe. See table below. .

Nominal Line size		Bore Size d for the following β 's: (a)			
		$\beta = 0.40$		$\beta = 0.65$	
mm	in	mm	in	mm	in
15	1/2	6.32	0.249	10.26	0.404
25	1	10.67	0.420	17.32	0.682
40	1 1/2	16.36	0.644	26.59	1.047
50	2	21.01	0.827	34.14	1.344
80	3	31.17	1.227	50.65	1.994
100	4	40.89	1.610	66.47	2.617

- (a) The larger β is generally selected for reduced pressure loss. The smaller β is generally selected to increase the measurement differential, or to minimize straight pipe runs upstream and downstream of the orifice. See "Recommended Straight Pipe Requirements" section.

Recommended Straight Pipe Requirements

The use of straight pipe upstream and downstream will reduce the effects of disturbances in the pipeline. The table below lists the recommended straight pipe required in pipe diameters.

Type of Disturbance	Pipe Diameters (a)(b)			
	for a $\beta = 0.40$		for a $\beta = 0.65$	
	Up	Down	Up	Down
Reducer	5	6 (3)	11 (6)	7 (3.5)
90° Bend or Tee	14 (7)	6 (3)	22 (11)	7 (3.5)
Two or More 90° Bends in Same Plane	18 (9)	6 (3)	32 (16)	7 (3.5)
Two or More 90° Bends in Different Planes	36 (18)	6 (3)	54 (27)	7 (3.5)
Expander	16 (8)	6 (3)	25 (13)	7 (3.5)
Globe Valve Fully Open	20 (10)	6 (3)	28 (14)	7 (3.5)
Gate Valve Fully Open	12 (6)	6 (3)	7 (3.5)	7 (3.5)

- (a) Recommended pipe diameters per ISO 5167.
- (b) Values in parentheses are associated with an additional 0.5% discharge coefficient uncertainty.

Approximate Weight (Excluding Transmitter) (a)

Nominal Line Size		Approximate Weight	
mm	in	kg	lb
15	1/2	1.81	4.0
25	1	2.04	4.5
40	1 1/2	2.38	5.3
50	2	2.72	6.0
80	3	3.52	7.8
100	4	4.31	9.5

- (a) See applicable transmitter PSS for transmitter weights.

MODEL CODES

Compact Orifice Ordering Code (AS Code)

	<u>AS Code</u>
Compact Orifice with Integral 3-Valve Manifold	CO
Pipeline Size	
DN 15 or 1/2 inch Pipe	-HH
DN 25 or 1 inch Pipe	-11
DN 40 or 1 1/2 inch Pipe	-1H
DN 50 or 2 in Pipe	-22
DN 80 or 3 inch Pipe	-33
DN 100 or 4 inch Pipe	-44
Beta Ratio	
0.40	4
0.65	6
Alignment Ring	
For use with ANSI Flanges	A
For use with DIN Flanges	D
Example: AS Code CO-224A	

(a) Refer to AS Code CI below if an optional installation kit is needed to assemble the orifice to the pipeline.

Installation Kit Optional Ordering Code (AS Code)

	<u>AS Code</u>
Installation Kit for Compact Orifice (a)	CI
Pipeline Size	
DN 15 or 1/2 inch Pipe	-HH
DN 25 or 1 inch Pipe	-11
DN 40 or 1 1/2 inch Pipe	-1H
DN 50 or 2 in Pipe	-22
DN 80 or 3 inch Pipe	-33
DN 100 or 4 inch Pipe	-44
Flange Rating	
ANSI Class 150 Flange	AN150
ANSI Class 300 Flange	AN300
ANSI Class 600 Flange	A0600
DIN PN 16	PN016
DIN PN 40	PN040
DIN PN 100	PN100
Example: AS Code CI-22AN150	

(a) The optional installation kit includes the bolts, nuts, and gaskets required to assemble the Model CO to the pipeline.

DIMENSIONS – NOMINAL

mm
in

MODEL CO WITH AN IDP10 TRANSMITTER HAVING A TRADITIONAL STRUCTURE
(SEE NEXT PAGES FOR AN IDP10 WITH LOW PROFILE/COPLANAR STRUCTURES)

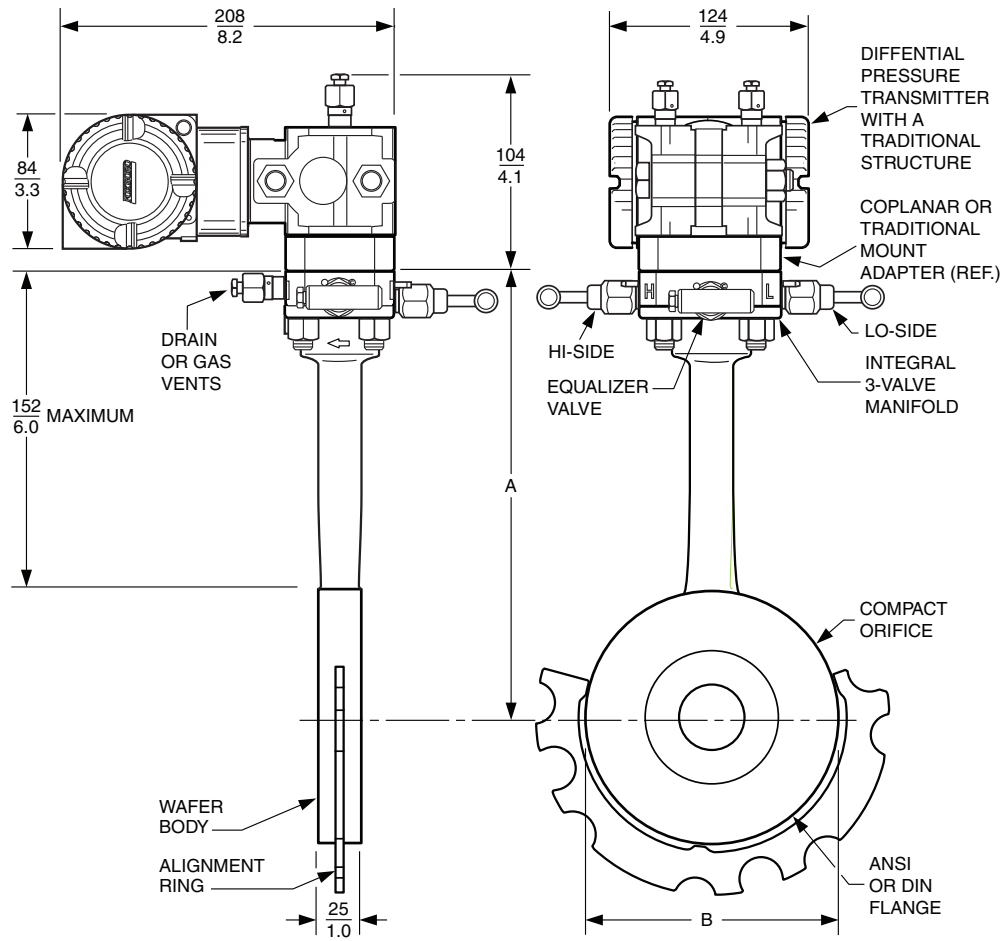

DIMENSION A AND DIAMETER B

Pipeline Size	Dimension A	Diameter B
DN 15 (1/2 in)	163 mm (6.4 in)	35 mm (1.38 in)
DN 25 (1 in)	170 mm (6.7 in)	51 mm (2.00 in)
DN 40 (1 1/2 in)	180 mm (7.1 in)	73 mm (2.88 in)
DN 50 (2 in)	190 mm (7.5 in)	92 mm (3.63 in)
DN 80 (3 in)	208 mm (8.2 in)	127 mm (5.00 in)
DN 100 (4 in)	224 mm (8.8 in)	157 mm (6.19 in)

mm
in

MODEL CO WITH AN IDP10 TRANSMITTER HAVING A LOW PROFILE (LP1)/COPLANAR STRUCTURE (SEE PREVIOUS PAGE FOR AN IDP10 WITH A TRADITIONAL STRUCTURE)

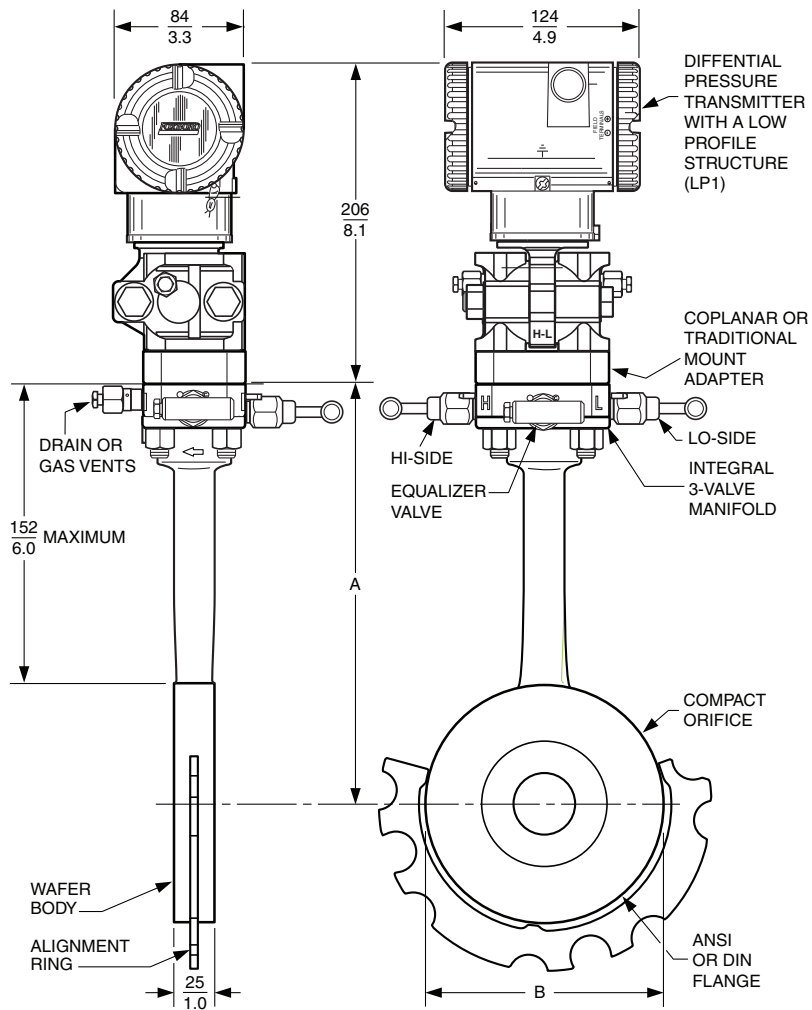

DIMENSION A AND DIAMETER B		
Pipeline Size	Dimension A	Diameter B
DN 15 (1/2 in)	163 mm (6.4 in)	35 mm (1.38 in)
DN 25 (1 in)	170 mm (6.7 in)	51 mm (2.00 in)
DN 40 (1 1/2 in)	180 mm (7.1 in)	73 mm (2.88 in)
DN 50 (2 in)	190 mm (7.5 in)	92 mm (3.63 in)
DN 80 (3 in)	208 mm (8.2 in)	127 mm (5.00 in)
DN 100 (4 in)	224 mm (8.8 in)	157 mm (6.19 in)

mm
in

MODEL CO WITH AN IDP10 TRANSMITTER HAVING A LOW PROFILE (LP2)/COPLANAR STRUCTURE
[SEE PREVIOUS PAGES FOR AN IDP10 WITH TRADITIONAL AND LOW PROFILE (LP1) STRUCTURES]

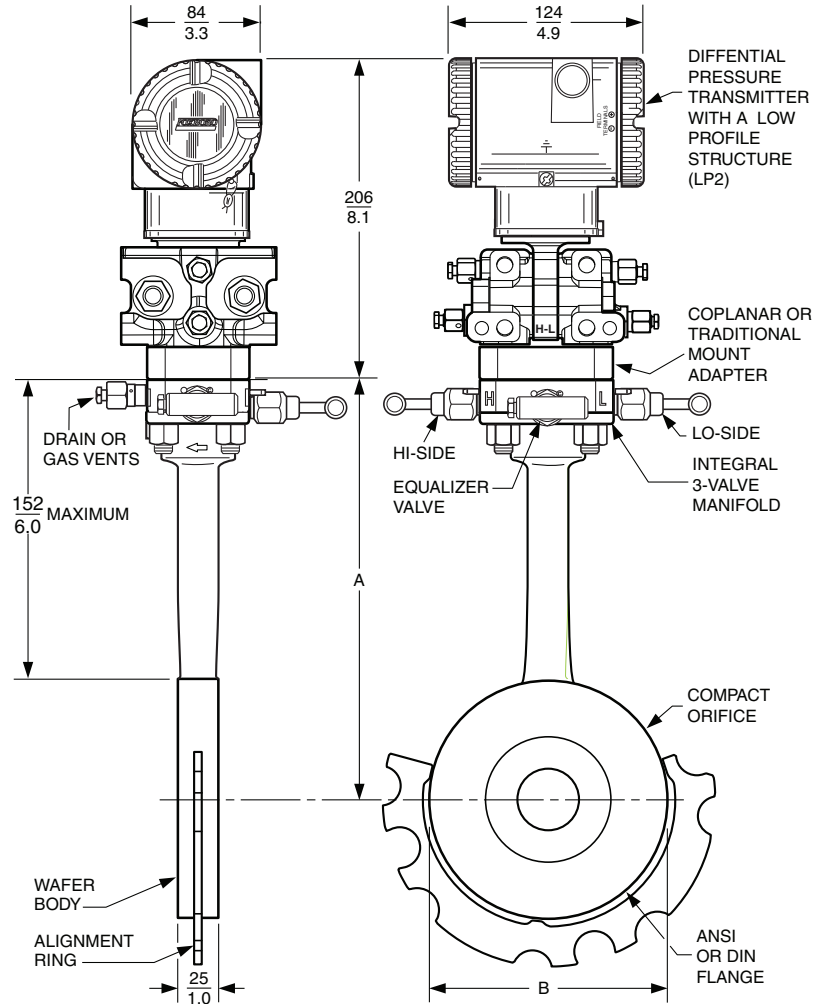

DIMENSION A AND DIAMETER B		
Pipeline Size	Dimension A	Diameter B
DN 15 (1/2 in)	163 mm (6.4 in)	35 mm (1.38 in)
DN 25 (1 in)	170 mm (6.7 in)	51 mm (2.00 in)
DN 40 (1 1/2 in)	180 mm (7.1 in)	73 mm (2.88 in)
DN 50 (2 in)	190 mm (7.5 in)	92 mm (3.63 in)
DN 80 (3 in)	208 mm (8.2 in)	127 mm (5.00 in)
DN 100 (4 in)	224 mm (8.8 in)	157 mm (6.19 in)

NOTES

ORDERING INSTRUCTIONS

1. Transmitter Model: See referenced PSS number on Page 2 table to specify transmitter required for assembly to the Compact Orifice.
2. Compact Orifice AS Number: specify using AS Code (see Ordering Code section).
3. Optional Installation Kit: specify using AS Code (see Ordering Code section).
4. User Tag and Application.

OTHER FOXBORO PRODUCTS

The Foxboro product lines offer a broad range of measurement and instrument products, including solutions for pressure, flow, analytical, temperature, positioning, controlling, and recording. For a list of these offerings, visit our web site at:

www.fielddevices.foxboro.com