

PSS 2A-1C13 L

Models IAP10 and IGP10 I/A Series[®] Absolute and Gauge Pressure Transmitters for Pulp and Paper Processes with Digital or Analog Output Signals



The Foxboro[®] brand I/A Series Models IAP10 and IGP10 Absolute and Gauge Pressure Transmitters with integral pulp and paper process connections are two-wire transmitters that provide precise, reliable measurement of gauge or absolute pressure, and provide a digital or analog output signal for local or remote configuration, monitoring, and control. They have been specifically designed for use with pulp and paper processes.

FEATURES

- ▶ Integral 1- and 1 1/2-inch sleeve and threaded type process connections.
- ▶ Threaded type process connection available to fit 1 1/2-inch Ametek spud.
- ▶ Digital Output versions with either FoxCom[™], HART[®], or FOUNDATION[™] Fieldbus Protocol.
- ▶ Analog Output version can be either 4 to 20 mA, or 1 to 5 V dc for low power installations.
- ▶ Fieldbus versions FISCO/FNICO compliant.
- ▶ SIL2-Certified Transmitter offered as an option for HART versions.
- ▶ 316L ss and nickel alloy⁽¹⁾ diaphragm materials
- ▶ Characterized with integral process connection for improved performance.
- ▶ Silicone fill fluid – low volume to minimize ambient temperature effects.
- ▶ Span limits to 2.1 MPa (to 300 psi)
- ▶ Aluminum housing has durable, corrosion-resistant Epoxy finish; 316 ss housing also available; both meet NEMA 4X and IP66 rating.
- ▶ Multi-marking is available for HART electronic versions only for FM, CSA, and ATEX intrinsically safe installations. The user determines and permanently marks on the data plate the certification to be applied.

1. Equivalent to Hastelloy[®] C-276. Hastelloy is a registered trademark of Haynes International, Inc.

- ▶ Complies with NAMUR NE 21 Interference Immunity requirement and NAMUR NE 43 analog output overrange and underrange annunciations.
- ▶ CE marked; complies with applicable EMC, ATEX, and PED European Directives.
- ▶ Complies with electromagnetic compatibility requirements of European EMC Directive 2004/108/EC by conforming to following EN and IEC standards: EN 61326-1, and IEC 61000-4-2 through 61000-4-6.
- ▶ Dual Seal certified by CSA to meet ANSI/ISA 12.27.01-2003 requirements.
- ▶ Numerous seal and transmitter options and accessories offered to expand the capabilities of these transmitters.
- ▶ Standard 5-year warranty.

I/A SERIES PRESSURE TRANSMITTER FAMILY

The I/A Series Electronic Pressure Transmitters are a complete family of d/p Cell[®], gauge, absolute, multirange, multivariable, and premium performance transmitters, as well as transmitters with remote or direct connect pressure seals, all using field-proven silicon strain gauge sensors and common topworks.

The family additionally includes transmitters, also with common topworks, specifically for use in sanitary, and pulp and paper processes.

Select the electronics module you need to provide just the right level of intelligence for your application and budget. If your needs change, the modular design allows easy migration to standards including FoxCom, HART, FOUNDATION Fieldbus, and Analog 4 to 20 mA or 1 to 5 V dc.

DIGITAL AND ANALOG OUTPUT VERSIONS

Digital output versions include transmitters with FoxCom, HART, and FOUNDATION fieldbus communication protocols. Analog output versions include 4 to 20 mA output and 1 to 5 V dc output.

Digital FoxCom or 4 to 20 mA dc (Version -D Electronics)

FoxCom Digital Output

Provides Measurement Integration with I/A Series systems, transmission of multiple measurements, and workstation configuration and diagnostics. Also provides digital communications with a PC-based configurator or optional LCD indicator with on-board pushbuttons for local configuration and calibration.

FoxCom 4 to 20 mA Output

Allows direct analog connection to common receivers while still providing full Intelligent Transmitter Digital Communications with a PC-based configurator, applicable I/A Series system FBMs, or optional LCD indicator with pushbuttons for configuration and calibration.

Digital HART and 4 to 20 mA dc (Version -T Electronics)

4 to 20 mA with HART communications. Allows direct analog connection to common receivers while still providing full intelligent digital communications using a HART Communicator or PC-based configurator.

In addition to HART, Foxboro pressure transmitters are also available with other protocols as described below.

Digital FOUNDATION Fieldbus - FISCO/FNICO Compliant (Version -F Electronics)

This all digital, serial, two-way communication system interconnects field devices, such as transmitters, actuators, and controllers. It is a Local Area Network (LAN) with built-in capability to distribute control application across the network. Fieldbus technology consists of a Physical Layer, a Communication Stack, and User Application Blocks.

The communication stack includes an LAS (Link Access Scheduler), and the user application software include an AI (Analog Input) and PID (Proportional/ Integral/Derivative) function blocks. Interoperability of Fieldbus devices is achieved using device addresses (IDs) and device descriptions (DDs).

4 to 20 mA dc Analog Output (Version -A Electronics)

Version -A transmitters are very cost effective analog output transmitters that provide full configuration capability. They provide the greatest functionality for the largest number of applications at the least possible cost to you.

They even provide the ability to rerange to new calibrated ranges, using the standard LCD indicator with on-board pushbuttons, without the need to apply calibration pressure.

They are explosionproof for use in Division 1 locations, and comply with Division 2 requirements.

1 to 5 V dc Analog Output (Version -V Electronics)

These low power, low voltage transmitters are both explosionproof and intrinsically safe and provide a standard LCD indicator with on-board pushbuttons for configuration and calibration. They provide:

- ▶ 1 to 5 V dc Output Signal
- ▶ 9 V dc Minimum Voltage
- ▶ 3 mA maximum current

INTEGRAL PROCESS CONNECTORS FOR PULP AND PAPER PROCESSES

All welded, integral, 316L stainless steel connector with sleeve or threaded type end connections.

Sleeve and threaded type connectors are offered in 1- and 1 1/2-in sizes with either a 316L ss or nickel alloy⁽²⁾ diaphragm. A 1 1/2-in threaded type with a nickel alloy (2) diaphragm is also offered to fit an Ametek spud.

2. Equivalent to Hastelloy® C-276.

HIGH PERFORMANCE

These transmitters utilize microprocessor-based correction to achieve both excellent accuracy and ambient temperature compensation.

OPTIONAL SIL2 TRANSMITTERS WITH HART PROTOCOL

Modern industrial processes tend to be technically complex and have the potential to inflict serious harm to persons or property during a mishap. The IEC 61508 standard defines safety as “freedom from unacceptable risk.” SIL2 pressure transmitters with HART communication protocol, in conjunction with Triconex Safety Systems, provide integrated solutions for safety and critical control applications. The integrated solution is certified as interference-free from the 4 to 20 mA loop; this guarantees the integrity of the safety system and the safety of the controlled process. The integrated design allows uninterrupted operation of the safety function, while allowing access to device level information via HART commands. The solution permits interface of device diagnostics with asset management systems without compromising functional safety. Select Option -S2 for a SIL2-certified HART Transmitter. A copy of the certification is available via Auxiliary Specification (AS) Code CERT-S.

DIRECT PROCESS MOUNTING

Because of their light weight, these transmitters can be directly connected to the process piping or tank spud without mounting brackets.

DEPENDABLE AND EFFICIENT DESIGN

- ▶ Silicon Strain Gauge Technology has been Field-Proven in hundreds of thousands of successful applications.
- ▶ Simple, elegant packaging uses a minimum of parts to achieve exceptionally high reliability.

EASE OF INSTALLATION

Rotatable Topworks allows transmitter installation in tight places, allows indicator to be positioned in preferred direction, and eases field retrofit.

Two Conduit Entrances offer a choice of entry positions for ease of installation and self-draining of condensation regardless of mounting position and topworks rotation.

Wiring Guides and Terminations provide ease of wire entry and support, plenty of space to work and store excess wire, and large, rugged, rugged screw terminals for easy wire termination.

LCD INDICATOR

A two-line indicator with on-board pushbuttons is available to display the measurement with a choice of units. (See Figure 1.) The pushbuttons allow zero and span adjustments as well as local configuration without the need for a PC-based configurator. This indicator is optional with the Digital Output transmitters, and standard with the Analog Output transmitters. When used with Analog Output transmitters, if local process indication is not required or desired, an optional blind (solid) cover can be substituted for the standard window cover.

NOTE

When an LCD indicator is used, ensure that the URV (upper range value) in the selected pressure units does not exceed the character capacity on the top line of the display; i.e., five numeric characters, or four with the analog output transmitters. This is especially important with analog output transmitters (Versions -A and -V) since the LCD must be used for data entry.

Figure 1. Topworks with LCD Indicator



FUNCTIONAL SPECIFICATIONS

Span and Range Limits

Span Limit Code	Span Limits			Range Limits (a)		
	kPa	inH ₂ O	mbar	kPa	inH ₂ O	mbar
B (b)	0.87 and 50	3.5 and 200	87 and 500	0 and 50	0 and 200	0 and 500
Code	MPa	psi	bar or kg/cm ²	MPa	psi	bar or kg/cm ²
C	0.007 and 0.21	1 and 30	0.07 and 2.1	0 and 0.21	0 and 30	0 and 2.1
D	0.07 and 2.1	10 and 300	0.7 and 21	0 and 2.1	0 and 300	0 and 21

- a. In gauge or absolute pressure units, as applicable.
- b. Span Code B applicable to IGP10 Gauge Pressure Transmitters having 1 1/2 inch process connectors only; the IAP10 is not available with Span Limit Code B.

Maximum Overrange Pressure Rating

Span Limit Code	Maximum Overrange Pressure (a)		
	kPa	inH ₂ O	mbar
B (b)	1.3	300	750
Code	MPa	psi	bar or kg/cm ²
C	0.31	45	3.15
D (c)	3.1	450	31.5

- a. Overrange pressure is maximum pressure that may be applied without causing damage to transmitter. Ratings are in gauge or absolute pressure units, as applicable.
- b. Code B applicable to IGP10 GP Transmitters only.
- c. Maximum working pressure of transmitter with threaded or Tri-Clamp connections is 2100 kPa (300 psi). When using Tri-Clamps, pressure rating is 2100 kPa (300 psi) or the pressure rating of the Tri-Clamp used, whichever is less. See "ACCESSORIES" section for Tri-Clamp ratings.

Zeroing for Nonzero-Based Ranges (For IGP10 with -D and -T Versions Only)

Dual Function Zeroing from the LCD pushbuttons allows zeroing with transmitter open to atmosphere, even when there is a nonzero-based range. This greatly simplifies position effect zeroing on many pressure and level applications. It also applies to the Optional External Zero Adjustment (below).

Suppressed Zero

Suppressed zero ranges are acceptable as long as the Span and Range Limits are not exceeded.

Optional External Zero Adjustment

An external pushbutton mechanism (Figure 3) is isolated from the electronics compartment and magnetically activates an internal reed switch through the housing. This eliminates a potential leak path for moisture or contaminants to get into the electronics compartment. This zero adjustment can be disabled by a configuration selection. It is offered with the IAP10 Transmitter only.

Zero and Span Adjustments

These adjustments can be initiated from the I/A Series Workstation (with applicable FBMs), the PC-based configurator, or the LCD indicator with on-board pushbuttons. Transmitters with Electronic Versions -A or -V require use of the LCD indicator with pushbuttons.

Current Outputs for Overrange, Fail, and Offline Conditions - FoxCom and HART Only

Parameter	FoxCom	HART
OFFLINE	User configurable between 4 and 20 mA	
SENSOR FAILURE	User configurable to Fail LO or Fail HI	
FAIL LO	3.60 mA	3.60 mA
UNDERRANGE	3.75 mA	3.80 mA
OVERRANGE	21.00 mA	20.50 mA
FAIL HI	22.00 mA	21.00 mA

Output Signal (as specified)

- ▶ **Version -D Electronics:** Digital FoxCom and/or 4 to 20 mA dc, configurable
- ▶ **Version -T Electronics:** Digital HART and 4 to 20 mA dc
- ▶ **Version -F Electronics:** Digital FOUNDATION fieldbus
- ▶ **Version -A Electronics:** Analog 4 to 20 mA dc
- ▶ **Version -V Electronics:** Analog 1 to 5 V dc, Low Power

Field Wiring Reversal

No transmitter damage.

Adjustable Damping

▶ Versions -D, -T, and -F Electronics

Transmitter response time is normally 0.75 s, and electronically adjustable to 0.00 (none), 0.25, 0.50, 1, 2, 4, 8, 16, or 32 seconds, whichever is greater, for a 90% recovery from an 80% input step as defined in ANSI/ISA S51.1 (for a 63.2% recovery, 0.5 s). Damping can be set in both the transducer and AI blocks with the -F version.

▶ Versions -A and -V Electronics

Transmitter response time is normally 0.75 s, and electronically adjustable to 0 (none), 2, 4, or 8 seconds, whichever is greater, for a 90% recovery from an 80% input step as defined in ANSI/ISA S51.1 (for a 63.2% recovery, 0.5 s).

Electronics and Sensor Temperatures

Readable from I/A Series system or PC-based configurator only. Measurement is transmitter temperature, not necessarily process temperature.

Supply Voltage

▶ Digital Output Versions -D, -T, -F

– Version -D Electronics (FoxCom)

Power supplied through I/A Series System.

– Version -T Electronics (HART)

Bidirectional digital signal superimposed on the 4 to 20 mA current signal.

– Version -F Electronics (FOUNDATION Fieldbus)

Power supplied through a specific Fieldbus power supply connected to the bus.

▶ 4 to 20 mA Output Versions -D, -T, -A

Nominal minimum supply voltage (Figure 2) is 11.5 V dc for Versions -D, -T, and -A. This value can be reduced to 11 V dc by using a jumper across test receptacles in the field wiring compartment terminal block. See Figure 8.

Figure 2. 4 to 20 mA Output, Supply Voltage vs. Output Load

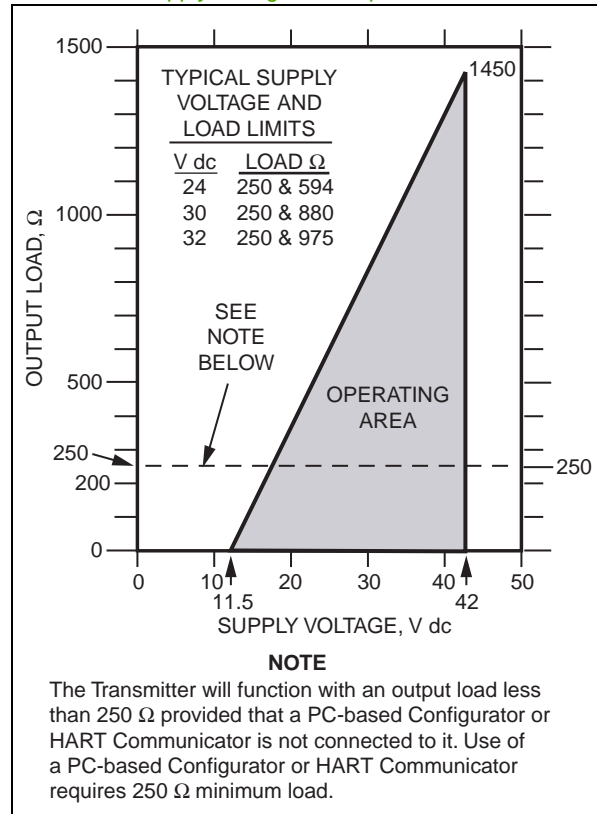

Write Protect Jumper (Electronic Versions -D, -T, and -F)

Can be positioned to lock out all configurators from making transmitter database changes. This makes transmitter suitable for Safety Shutdown System Applications that require this feature.

Liquid Crystal Display (LCD) Indicator with On-Board Pushbuttons

This indicator is standard with the -A and -V electronic versions, and optional with the -D, -T, and -F electronic versions. The indicator provides:

- ▶ Two Lines; five numeric characters on top line (four when a minus sign is needed; also four with Electronic Versions -A and -V) and seven alphanumeric characters on bottom line.
- ▶ Measurement Readout; value on top line and units label on bottom line.
- ▶ Configuration and Calibration Prompts.

Figure 3. LCD Indicator with Pushbuttons

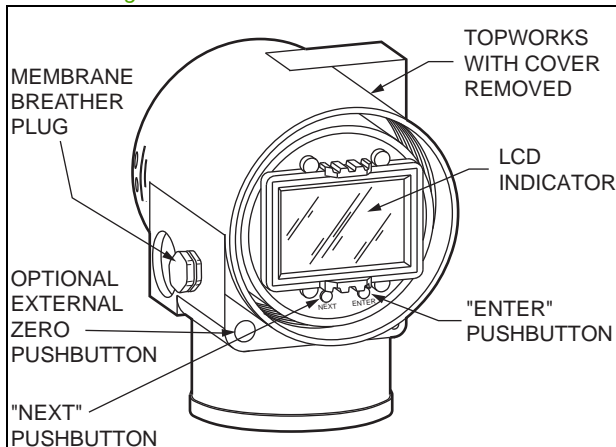

NOTE

A membrane breather plug is used with IGP10 Transmitters only.

Configuration and Calibration Data, and Electronics Upgradeability

All factory characterization data and user configuration and calibration data are stored in the sensor. This means that the electronics module may be replaced, with one of like type, without the need for reconfiguration or recalibration. Although module replacement can affect accuracy by a maximum of 0.20% of span, this error can be removed by an mA trim without application of pressure (not with Fieldbus).

Changing module types (e.g., from one protocol to another protocol) may require reconfiguration and recalibration, as well as a different terminal block, but all factory characterization data is retained.

Pressure Units for Calibrated Range

Table 1. Allowable Pressure Units for Calibrated Range (a)

inH ₂ O	mH ₂ O (b)	dy/cm ² (c)	torr	kg/cm ²
ftH ₂ O	inHg	Pa	mbar	psi
mmH ₂ O	mmHg	kPa	bar	atm
cmH ₂ O	cmHg	MPa	g/cm ²	

- a. Gauge or absolute pressure units, as applicable.
- b. mH₂O only available with HART (-T) electronic version.
- c. Dy/cm² only available with FoxCom (-D) electronic version.

FoxCom (Version -D) Communications

- ▶ **Digital Mode (Fixed Current)**
Output signal is updated 10 times per second and carries the pressure, and sensor and electronics temperature measurements. See Table 2 for communication parameters and Figure 4 for a block diagram.
- ▶ **4 to 20 mA Analog Mode**
Output signal is updated a minimum of 30 times per second. A minimum loop load of 250 ohms is required. See Table 2 for communication parameters and Figure 5 for a block diagram.

HART (Version -T) Communications

- ▶ **4 to 20 mA Analog Mode**
Analog output signal is updated 30 times per second. A minimum loop load of 250 ohms is required. See Table 2 for communication parameters and Figure 5 for 4 to 20 mA output block diagram.
- ▶ **Multidrop Mode (Fixed Current)**
This Mode supports communications with up to 15 transmitters on a single pair of signal/power wires. The output signal is updated 4 times/second. A minimum loop load of 250 ohms is required. See Table 2 for communication parameters and Figure 6 for a typical multidrop block diagram.

FOUNDATION Fieldbus (Version -F) Communications

The Fieldbus is a serial, two-way communication systems that run at 31.25 kbits/s. The digital output signal is superimposed on the dc power signal on the bus, and controlled by a strict cycle schedule and protocol. Supply voltage, 9 to 32 V dc, is by a specific Fieldbus power source. Current consumption is 19.5 mA. The maximum number of devices on a non-intrinsically safe bus is 32. For intrinsically safe bus systems, the maximum number is 5. See Table 2 for communication parameters and Figure 7 for a typical installation topology.

Analog Output Version -A

This version provides a 4 to 20 mA analog output signal and also full configuration capability using the standard LCD indicator with pushbuttons. Also, reranging to new calibrated ranges is allowed without the need to apply calibration pressure.

Analog Output Version -V

This low power, low voltage version provides a 1 to 5 V output signal. As with Version -A, it allows full configuration capability, and reranging without applying calibration pressure, using the standard LCD indicator with pushbuttons.

Table 2. Communication Parameters - FoxCom, HART, and FOUNDATION Fieldbus

Parameter	FoxCom		HART		Fieldbus
	Analog Mode	Digital Mode	Analog Mode	Multidrop Mode	Digital
Remote Configurator	PC-based Configurator, or I/A Series System		HART Communicator or PC-based Configurator		I/A Series System, PC Host, or Fieldbus Certified Host
Communication Rate	600 baud	4800 baud	1200 baud	1200 baud	31.25 kbits/s
Communication Distance (Rated)	1800 m (6000 ft)	600 m (2000 ft)	3050 m (10 000 ft)	1525 m (5000 ft)	1900 m (a) (6235 ft) (a)

a. The total bus length including all spurs. Maximum spur length is 120 m (395 ft). For hybrid installations, the maximum IS spur length is dependent on the field barrier used. For intrinsically safe installations, maximum spur length is 30 m (98 ft).

Figure 4.
Digital Output Block Diagram
(FoxCom)

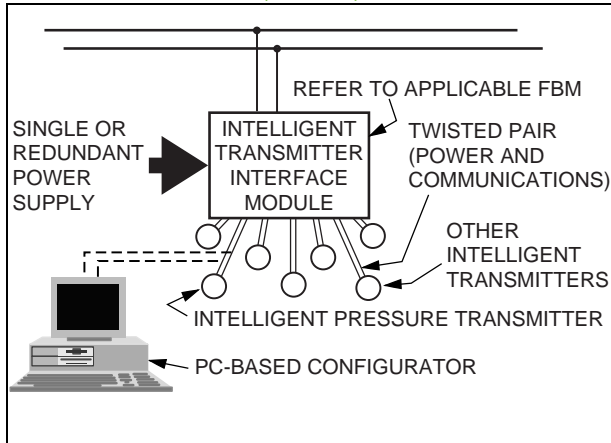

Figure 5.
4 to 20 mA Output Block Diagram
(FoxCom and HART)

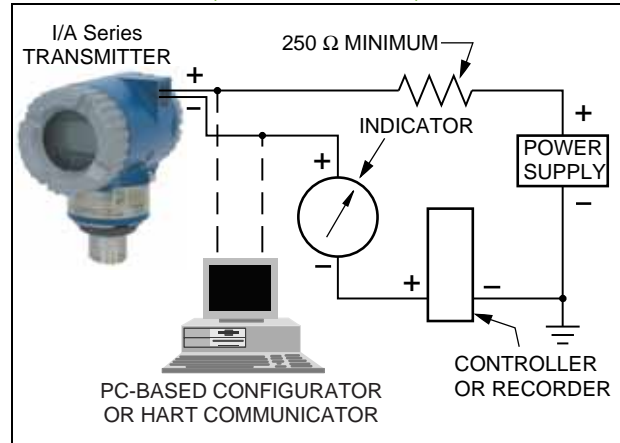

Figure 6.
Typical Multidrop Block Diagram
(HART – Up to Fifteen Transmitters)

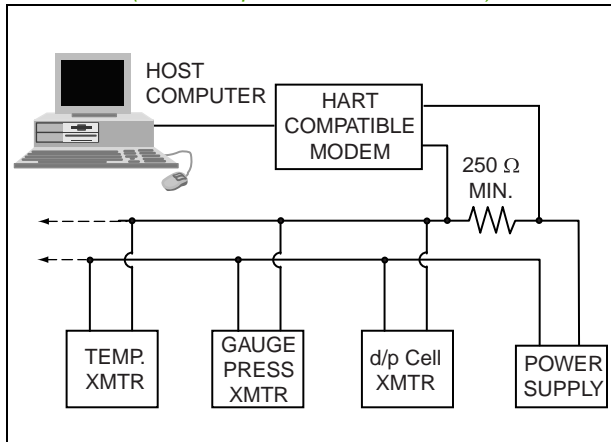
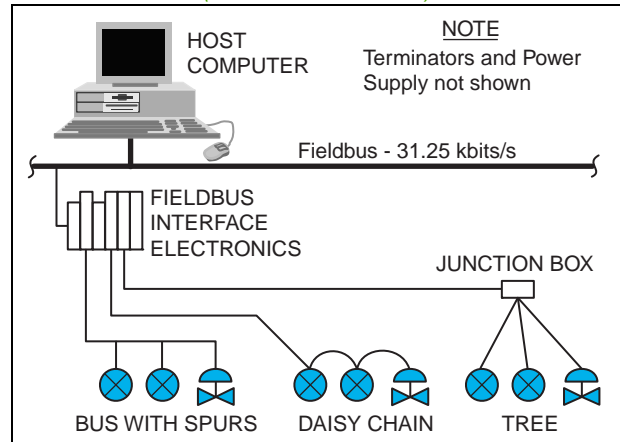

Figure 7.
Miscellaneous Installation Topologies
(FOUNDATION Fieldbus)



OPERATING, STORAGE, AND TRANSPORTATION CONDITIONS

Influence	Reference Operating Conditions	Normal Operating Conditions (a)	Operative Limits (a)	Transportation/Storage Limits
Process Connection Temp.	24 ±2°C (75 ±3°F)	-29 to +82°C (-20 to +180°F)	-46 and +121°C (-50 and +250°F)	Not Applicable
Electronics Temperature	24 ±2°C (75 ±3°F)	-29 to +82°C (-20 to +180°F)	-40 and +85°C (c) (-40 and +185°F) (c)	-54 and +85°C (-65 and +185°F)
▶ with LCD Indicator (b)	24 ±2°C (75 ±3°F)	-20 to +82°C (-4 to +180°F)	-29 and +85°C (c) (-20 and +185°F) (c)	-54 and +85°C (-65 and +185°F)
Relative Humidity (d)	50 ±10%	0 to 100%	0 and 100%	0 and 100% Noncondensing
mA Output				
▶ Supply Voltage	30 ±0.5 V dc	11.5 to 42 V dc (e)	11.5 and 42 V dc (e)	Not Applicable
▶ Output Load	650 Ω	0 to 1450 Ω (f)	0 and 1450 Ω (f)	Not Applicable
Voltage Output				
▶ Supply Voltage	12.5 ±0.5 V dc	9 to 15.5 V dc	9 and 30 V dc	Not Applicable
▶ Supply Current	(g)	(g)	(g)	Not Applicable
▶ Output Load	10 MΩ	1 to 10 MΩ	(h)	Not Applicable
FOUNDATION Fieldbus				
▶ Supply Voltage (i)	30 ±0.5 V dc	9 to 32 V dc	9 and 32 V dc	Not Applicable
Vibration	1 m/s ² (0.1 "g")	6.3 mm (0.25 in) Double Amplitude: from 5 to 15 Hz with Aluminum Housing and from 5 to 9 Hz with 316 ss Housing 0 to 30 m/s ² (0 to 3 "g") from 15 to 500 Hz with Aluminum Housing 0 to 10 m/s ² (0 to 1 "g") from 9 to 500 Hz with 316 ss Housing		11 m/s ² (1.1 "g") from 2.5 to 5 Hz (in Shipping Package)
Mounting Position	Upright	Upright	No Limit	Not Applicable

- a. Normal Operating Conditions and Operative Limits are defined per ANSI/ISA 51.1-1979 (R1993).
- b. Although the LCD will not be damaged at any temperature within the Transportation/Storage Limits, updates will be slowed and readability decreased at temperatures outside the Normal Operating Conditions.
- c. Refer to the Electrical Safety Specifications section for a restriction in electronic temperature limits with certain electrical approvals/certifications.
- d. With topworks covers on and conduit entrances sealed.
- e. 11.5 V dc can be reduced to 11 V dc by using a plug-in shorting bar with -D, -T, and -A electronic versions. See Figure 8.
- f. 250 Ω minimum load required for proper communication with FoxCom and HART Protocol. See Figure 2.
- g. Supply Current: 3 mA maximum demand within operative limits.
- h. Operative limits are 100 kΩ to open circuit, 0.2 μf maximum.
- i. Power supplied by a specific Fieldbus power supply.

PERFORMANCE SPECIFICATIONS

*Zero-Based Calibrations; Under Reference Operating Conditions Unless Otherwise Specified;
URL = Upper Range Limit; Span = Calibrated Span*

Accuracy (Includes Linearity, Hysteresis, and Repeatability)

±0.20% of Span

Small Span Accuracy

For Span Code	If Span is:	Then Small Span Accuracy in % of Span is:
B (a)	<5% of URL	$\pm \left[(0.10) + (0.005) \left(\frac{URL}{Span} \right) \right]$
C and D	<6.7% of URL	$\pm \left[(0.10) + (0.0067) \left(\frac{URL}{Span} \right) \right]$

a. Span Code B applicable to IGP10 Transmitter only.

Power-Up Time

Less than 5 seconds for output to reach first valid measurement.

Stability

Long term drift is less than ±0.02% of URL per year over a 5-year period.

Calibration Frequency

The calibration frequency is five years. The five years is derived using the values of allowable error (% span), TPE (% span), performance margin (% span), and stability (% span/month); where:

$$\text{Calibration Frequency} = \frac{\text{Performance Margin}}{\text{Stability}} = \text{Months}$$

Supply Voltage Effect

The output changes less than 0.005% of span for each 1 V change within the specified supply voltage requirements.

Vibration Effect

Total effect is ±0.2% of URL per “g” for vibrations in the frequency range of 5 to 500 Hz; with double amplitudes of 6.3 mm (0.25 in) in the range of 5 to 15 Hz, or accelerations of 3 “g” in the range of 15 to 500 Hz, whichever is smaller, for aluminum housings; and with double amplitudes of 6.3 mm (0.25 in) in the range of 5 to 9 Hz, or accelerations of 1 “g” in the range of 9 to 500 Hz, whichever is smaller, for 316 ss housings.

Position Effect

The transmitter may be mounted in any position. Any zero effect caused by the mounting position can be eliminated by rezeroing. There is no span effect.

Ambient Temperature Effect

Total effect for a 28°C (50°F) change within Normal Operating Condition limits is:

- ▶ For Electronics Version -D, -T, or -F
±(0.06% URL + 0.12% Span)
- ▶ For Electronics Version -A or -V
±(0.10% URL + 0.15% span)

RFI Effect

The output error is less than 0.1% of span for radio frequencies in the range of 27 to 1000 MHz and field intensity of 10 V/m when the transmitter is properly installed with shielded conduit and grounding, and housing covers are in place.
(Per IEC Std. 61000-4-3.)

Switching and Indirect Lightning Transients

The transmitter can withstand a transient surge up to 2000 V common mode or 1000 V normal mode without permanent damage. The output shift is less than 1.0%. (Per ANSI/IEEE C62.41-1980 and IEC Std. 61000-4-5.)

PHYSICAL SPECIFICATIONS

Environmental Protection

The enclosure has the dusttight and weatherproof rating of IP66 as defined by IEC 60529 and provides the environmental and corrosion resistant protection rating of NEMA 4X.

Electronics Housing and Housing Covers

Housing has two compartments to separate the electronics from the field connections. The housing and covers are made from low copper (0.6% maximum) die-cast aluminum alloy with an epoxy finish, or from 316 ss. Buna-N O-ring seals are used to seal the threaded housing covers, housing neck, and terminal block.

Process Wetted Parts

- ▶ 316L ss
- ▶ Nickel alloy⁽³⁾ diaphragm material also available - see "MODEL CODE"

Process O-Rings (Sleeve Type)

Viton

Process Gasket (Threaded Type)

Gylon (filled ptfe)

Process Connectors

Threaded or sleeve mounting

Sensor Fill Fluid

Silicone

Mounting Position

The transmitter may be mounted in any orientation.

Electronics Module

Printed wiring assemblies are conformally coated for moisture and dust protection.

Electrical Conduit Connections

Field wires enter through 1/2 NPT, PG 13.5, or M20 conduit connection on both sides of transmitter housing. Unused connection must be plugged (use metal plug that is supplied) to ensure moisture and RFI protection. Optional conduit thread adapters are also offered.

Electrical Terminations

Field wires enter through the conduit connections described above and terminate under screw terminals and washers on the terminal block in the field terminals compartment. See Figure 8 for the terminal block configuration for the different transmitter electronic versions offered.

Approximate Mass

- ▶ Less than 2 kg (4.5 lb), depending on process connector type and size selected, when aluminum housing is used.
- ▶ Add 1.1 kg (2.4 lb) if 316 ss housing is used.
- ▶ Add 0.2 kg (0.4 lb) if LCD indicator is used.

3. Equivalent to Hastelloy® C-276.

Figure 8. Field Terminals Compartment for the Electronic Versions Offered

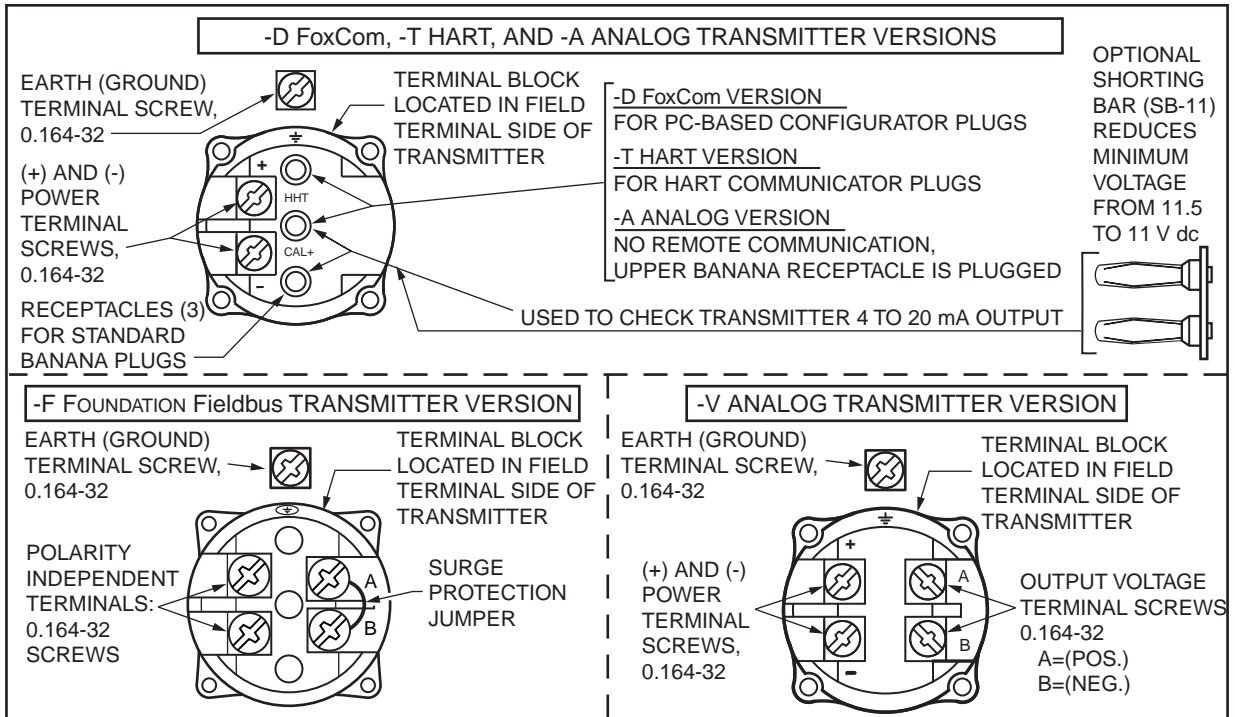

ELECTRICAL SAFETY SPECIFICATIONS

Transmitter has been designed to meet the Electrical Safety Specifications listed in the tables below. Contact Global Customer Support for information or status of testing laboratory approvals or certifications.

Refer to applicable instruction manual for application conditions and connectivity requirements.

Electronic Version -D (FoxCom)

Testing Laboratory, Types of Protection, and Area Classification	Application Conditions	Elec. Safety Design Code
ATEX intrinsically safe; II 1 GD, EEx ia IIC, Zone 0, or II 1/2 GD EEx ib IIC, Zone 0 and 1.	Temperature Class T4; Ta = -40 to +80°C Temperature Class T5; Ta = -40 to +40°C Temperature Class T6; Ta = -40 to +40°C	E
ATEX protection n; II 3 GD, EEx nL IIC, Zone 2.	Temperature Class T4; Ta = -40 to +80°C Temperature Class T5; Ta = -40 to +70°C Temperature Class T6; Ta = -40 to +40°C	N
ATEX multiple certifications, ia & ib, and n. Refer to Codes E and N for details.	Applies to Codes E and N.	M (a)
CSA intrinsically safe for Class I, Div. 1, Groups A, B, C, and D, Class II, Div. 1, Groups E, F, and G, and Class III, Div. 1.	Temperature Class T6 at 40°C, and T4A at 85°C maximum ambient.	C (IAP10 only)
CSA explosionproof for Class I, Div. 1, Groups B, C, and D; dust-ignitionproof for Class II, Div. 1, Groups E, F, and G; Class III, Div. 1.	Maximum Ambient Temperature 85°C.	C (IAP10 only)
CSA for Class I, Div. 2, Groups A, B, C, and D; Class II, Div. 2, Groups F and G; Class III, Div. 2.	Temperature Class T6 at 40°C and T4A at 85°C maximum ambient.	C (IAP10 only)
CSA intrinsically safe for Class I, Div. 1, Groups A, B, C, and D, Class II, Div. 1, Groups E, F, and G, and Class III, Div. 1.	Temperature Class T6 at 40°C, and T4A at 85°C maximum ambient.	L (IGP10 only)
CSA for Class I, Div. 2, Groups A, B, C, and D; Class II, Div. 2, Groups F and G; Class III, Div. 2.	Temperature Class T6 at 40°C and T4A at 85°C maximum ambient.	L (IGP10 only)
FM intrinsically safe for Class I, Div. 1, Groups A, B, C, and D; Class II, Div. 1, Groups E, F, and G; and Class III, Div. 1.	Temperature Class T4A at 40°C and T4 at 85°C maximum ambient.	F (IAP10 only)
FM explosionproof for Class I, Div. 1, Groups B, C, and D; dust-ignitionproof for Class II, Div. 1, Groups E, F, and G; Class III, Div. 1.	Temperature Class T6 at 80°C and T5 at 85°C maximum ambient.	F (IAP10 only)
FM nonincendive for Class I, Div. 2, Groups A, B, C, and D; Class II, Div. 2, Groups F and G; Class III, Div. 2.	Temperature Class T4A at 40°C and T4 at 85°C maximum ambient.	F (IAP10 only)
FM intrinsically safe for Class I, Div. 1, Groups A, B, C, and D; Class II, Div. 1, Groups E, F, and G; Class III, Div. 1.	Temperature Class T4A at 40°C and T4 at 85°C maximum ambient.	R (IGP10 only)
FM nonincendive for Class I, Div. 2, Groups A, B, C, and D; Class II, Div. 2, Groups F and G; Class III, Div. 2.	Temperature Class T4A at 40°C and T4 at 85°C maximum ambient.	R (IGP10 only)

- a. With ATEX Electrical Safety Design Code M, the user must permanently mark (check off on rectangular box on data plate) one type of protection only (ia and ib, or n). Do not change this mark once it has been applied.

Electronic Version -T (HART)

Testing Laboratory, Types of Protection, and Area Classification	Application Conditions	Elec. Safety Design Code
ATEX intrinsically safe; II 1 GD, EEx ia IIC, Zone 0, or II 1/2 GD EEx ib IIC, Zone 0 and 1.	Temperature Class T4; Ta = -40 to +80°C Temperature Class T5; Ta = -40 to +40°C Temperature Class T6; Ta = -40 to +40°C	E
ATEX protection n; II 3 GD, EEx nL IIC, Zone 2.	Temperature Class T4; Ta = -40 to +80°C Temperature Class T5; Ta = -40 to +70°C Temperature Class T6; Ta = -40 to +40°C	N
ATEX multiple certifications, ia & ib, and n. Refer to Codes E and N for details.	Applies to Codes E and N.	M (a)
CSA explosionproof for Class I, Div. 1, Groups B, C, and D; dust-ignitionproof for Class II, Div. 1, Groups E, F, and G; Class III, Div. 1.	Maximum Ambient Temperature 85°C.	C (IAP10 only)
CSA for Class I, Div. 2, Groups A, B, C, and D; Class II, Div. 2, Groups F and G; Class III, Div. 2.	Temperature Class T6 at 40°C and T4A at 85°C maximum ambient.	C (IAP10 only)
CSA zone certified intrinsically safe Ex ia IIC, and energy limited Ex nA II.	Temperature Class T4 at 40°C, and T3 at 85°C maximum ambient.	B (IAP10 only)
CSA intrinsically safe for Class I, Div. 1, Groups A, B, C, and D; Class II, Div. 1, Groups E, F, and G; Class III, Div. 1.	Temperature Class T6 at 40°C and T4A at 85°C maximum ambient.	L (IGP10 only)
CSA for Class I, Div. 2, Groups A, B, C, and D; Class II, Div. 2, Groups F and G; Class III, Div. 2.	Temperature Class T6 at 40°C and T4A at 85°C maximum ambient.	L (IGP10 only)
CSA zone certified intrinsically safe Ex ia IIC and energy limited Ex nA II.	Temperature Class T4 at 40°C and T3 at 85°C maximum ambient.	L (IGP10 only)
FM intrinsically safe for Class I, Div. 1, Groups A, B, C, and D; Class II, Div. 1, Groups E, F, and G; and Class III, Div. 1.	Temperature Class T4A at 40°C and T4 at 85°C maximum ambient.	F (IAP10 only)
FM explosionproof for Class I, Div. 1, Groups B, C, and D; dust-ignitionproof for Class II, Div. 1, Groups E, F, and G; Class III, Div. 1.	Temperature Class T6 at 80°C and T5 at 85°C maximum ambient.	F (IAP10 only)
FM nonincendive Class I, Div. 2, Groups A, B, C, and D; Class II, Div. 2, Groups F and G; and Class III, Div. 2.	Temperature Class T4A at 40°C and T4 at 85°C maximum ambient.	F (IAP10 only)
FM zone certified intrinsically safe AEx ia IIC.	Temperature Class T4 at 85°C maximum ambient.	F (IAP10 only)
FM intrinsically safe for Class I, Div. 1, Groups A, B, C, and D; Class II, Div. 1, Groups E, F, and G; Class III, Div. 1.	Temperature Class T4A at 40°C and T4 at 85°C maximum ambient.	R (IGP10 only)
FM nonincendive for Class I, Div. 2, Groups A, B, C, and D; Class II, Div. 2, Groups F and G; Class III, Div. 2.	Temperature Class T4A at 40°C and T4 at 85°C maximum ambient.	R (IGP10 only)
FM zone certified intrinsically safe AEx ia IIC.	Temperature Class T4 at 85°C maximum ambient.	R (IGP10 only)
IECEX field device intrinsically safe; Ex ia IIC, Zone 0.	Temperature Class T4; Ta = -40 to +80°C.	T

Electronic Version -T (HART) (Continued)

Testing Laboratory, Types of Protection, and Area Classification	Application Conditions	Elec. Safety Design Code
IECEX field device protection n; Ex nL IIC, Zone 2.	Temperature Class T4; Ta = -40 to +80°C.	U
Multi-marked for HART as follows: <ul style="list-style-type: none"> ▶ ATEX intrinsically safe, II 1 GD, EEx ia IIC, Zone 0. ▶ CSA intrinsically safe, Cl. I, Div. 1, Groups A, B, C, D; Class II, Div. 1, Groups E, F, G; Class III, Div. 1; also CSA zone certified intrinsically safe Ex ia IIC. ▶ FM intrinsically safe, Cl. I, Div. 1, Groups A, B, C, D; Class II, Div. 1, Groups E, F, G; Class III, Div. 1. Also FM zone certified intrinsically safe AEx ia IIC. 	<ul style="list-style-type: none"> ▶ See application conditions for Code E intrinsically safe applications. ▶ See application conditions for Code C intrinsically safe applications. ▶ See application conditions for Code F intrinsically safe applications. 	W (b)

- a. With ATEX Electrical Safety Design Code M, the user must permanently mark (check off on rectangular box on data plate) one type of protection only (ia and ib, or n). Do not change this mark once it has been applied.
- b. When selecting Safety Design Code W (for HART only), the user must permanently mark (check off in rectangular block on data plate) intrinsically safe certifications for ATEX, CSA, or FM, as applicable. Do not change this mark once it has been applied.

Electronic Version -F (FOUNDATION Fieldbus)

Testing Laboratory, Types of Protection, and Area Classification	Application Conditions	Elec. Safety Design Code
ATEX FISCO field device intrinsically safe; II 1 G, EEx ia IIC, Zone 0.	Temperature Class T4; Ta = -40 to +80°C.	E
ATEX FNICO field device protection n: II 3, G EEx nL IIC, Zone 2.	Temperature Class T4; Ta = -40 to +80°C.	N
CSA explosionproof for Class I, Div. 1, Groups B, C, and D; dust-ignitionproof for Class II, Div. 1, Groups E, F, and G; Class III, Div. 1.	Maximum Ambient Temperature 85°C.	C (IAP10 only)
CSA zone certified intrinsically safe Ex ia IIC and energy limited Ex nA II.	Temperature Class T4 at 40°C and T3 at 85°C maximum ambient.	C (IAP10 only)
CSA FISCO field device intrinsically safe for Class I, Div. 1, Groups A, B, C, and D; Class II, Div. 1, Groups E, F, G; Class III Div. 1.	Temperature Class T6 at 40°C and T4A at 85°C maximum ambient.	C (IAP10 only)
CSA FNICO field device for Class I, Div. 2, Groups A, B, C, and D; Class II, Div. 2, Groups F and G; Class III Div. 2.	Temperature Class T6 at 40°C and T4A at 85°C maximum ambient.	C (IAP10 only)
CSA zone certified intrinsically safe Ex ia IIC and energy limited Ex nA II.	Temperature Class T4 at 40°C and T3 at 85°C maximum ambient.	L (IGP10 only)
CSA FISCO field device intrinsically safe for Class I, Div. 1, Groups A, B, C, and D; Class II, Div. 1, Groups E, F, G; Class III Div. 1.	Temperature Class T6 at 40°C and T4A at 85°C maximum ambient.	L (IGP10 only)
CSA FNICO field device for Class I, Div. 2, Groups A, B, C, and D; Class II, Div. 2, Groups F and G; Class III Div. 2.	Temperature Class T6 at 40°C and T4A at 85°C maximum ambient.	L (IGP10 only)

Electronic Version -F (FOUNDATION Fieldbus) (Continued)

Testing Laboratory, Types of Protection, and Area Classification	Application Conditions	Elec. Safety Design Code
FM explosionproof for Class I, Div. 1, Groups B, C, and D; dust-ignitionproof for Class II, Div. 1, Groups E, F, and G; Class III, Div. 1.	Temperature Class T6 at 80°C and T5 at 85°C maximum ambient.	F (IAP10 only)
FM zone certified intrinsically safe AEx ia IIC.	Temperature Class T4 at 85°C maximum ambient.	F (IAP10 only)
FM FISCO field device intrinsically safe for Class I, Div. 1, Groups A, B, C, and D; Class II, Div. 1, Groups E, F, G; Class III Div. 1.	Temperature Class T4A at 40°C and T4 at 85°C maximum ambient.	F (IAP10 only)
FM FNICO field device nonincendive for Class I, Div. 2, Groups A, B, C, and D; Class II, Div. 2, Groups F and G; Class III, Div. 2.	Temperature Class T4A at 40°C and T4 at 85°C maximum ambient.	F (IAP10 only)
FM zone certified intrinsically safe AEx ia IIC.	Temperature Class T4 at 85°C maximum ambient.	R (IGP10 only)
FM FISCO field device intrinsically safe for Class I, Div. 1, Groups A, B, C, and D; Class II, Div. 1, Groups E, F, G; Class III Div. 1.	Temperature Class T4A at 40°C and T4 at 85°C maximum ambient.	R (IGP10 only)
FM FNICO field device nonincendive for Class I, Div. 2, Groups A, B, C, and D; Class II, Div. 2, Groups F and G; Class III, Div. 2.	Temperature Class T4A at 40°C and T4 at 85°C maximum ambient.	R (IGP10 only)
IECEX FISCO field device intrinsically safe: Ex ia IIC, Zone 0.	Temperature Class T4; Ta = -40 to +80°C.	T
IECEX FNICO field device protection n;: Ex nL IIC, Zone 2.	Temperature Class T4; Ta = -40 to +80°C.	U

Electronic Version -A (4 to 20 V dc Analog Output)

Testing Laboratory, Types of Protection, and Area Classification	Application Conditions	Elec. Safety Design Code
CSA explosionproof for Class I, Div. 1, Groups B, C, and D; dust-ignitionproof for Class II, Div. 1, Groups E, F, and G; Class III, Div. 1.	Maximum Ambient Temperature 85°C.	C (IAP10 only)
CSA for Class I, Div. 2, Groups A, B, C, and D; Class II, Div. 2, Groups F and G; Class III, Div. 2.	Temperature Class T6 at 40°C and T4A at 85°C maximum ambient.	C (IAP10 only)
CSA for Class I, Div. 2, Groups A, B, C, and D; Class II, Div. 2, Groups F and G; Class III, Div. 2.	Temperature Class T6 at 40°C and T4A at 85°C maximum ambient.	L (IGP10 only)
FM explosionproof for Class I, Div. 1, Groups B, C, and D; dust-ignitionproof for Class II, Div. 1, Groups E, F, and G; Class III, Div. 1.	Temperature Class T6 at 80°C and T5 at 85°C maximum ambient.	F (IAP10 only)
FM nonincendive for Class I, Div. 2, Groups A, B, C, and D; Class II, Div. 2, Groups F and G; Class III, Div. 2.	Temperature Class T4A at 40°C and T4 at 85°C maximum ambient.	F (IAP10 only)
FM nonincendive for Class I, Div. 2, Groups A, B, C, and D; Class II, Div. 2, Groups F and G; Class III, Div. 2.	Temperature Class T4A at 40°C and T4 at 85°C maximum ambient.	R (IGP10 only)

Electronic Version -V (1 to 5 V dc Analog Output)

Testing Laboratory, Types of Protection, and Area Classification	Application Conditions	Elec. Safety Design Code
CSA intrinsically safe for Class I, Div. 1, Groups A, B, C, and D; Class II, Div. 1, Groups E, F, and G; Class III, Div. 1.	Temperature Class T6 at 40°C and T4A at 85°C maximum ambient.	C (IAP10 only)
CSA explosionproof for Class I, Div. 1, Groups B, C, and D; dust-ignitionproof for Class II, Div. 1, Groups E, F, and G; Class III, Div. 1.	Maximum Ambient Temperature 85°C.	C (IAP10 only)
CSA zone certified intrinsically safe Ex ia IIC and energy limited Ex nA II.	Temperature Class T4 at 40°C and T3 at 85°C maximum ambient.	C (IAP10 only)
CSA intrinsically safe for Class I, Div. 1, Groups A, B, C, and D; Class II, Div. 1, Groups E, F, and G; Class III, Div. 1.	Temperature Class T6 at 40°C and T4A at 85°C maximum ambient.	L (IGP10 only)
CSA zone certified intrinsically safe Ex ia IIC and energy limited Ex nA II.	Temperature Class T4 at 40°C and T3 at 85°C maximum ambient.	L (IGP10 only)
FM intrinsically safe for Class I, Div. 1, Groups A, B, C, and D; Class II, Div. 1, Groups E, F, and G; Class III, Div. 1.	Temperature Class T4A at 40°C and T4 at 85°C maximum ambient.	F (IAP10 only)
FM explosionproof for Class I, Div. 1, Groups B, C, and D; dust-ignitionproof for Class II, Div. 1, Groups E, F, and G; Class III, Div. 1.	Temperature Class T6 at 80°C and T5 at 85°C maximum ambient.	F (IAP10 only)
FM nonincendive for Class I, Div. 2, Groups A, B, C, and D; Class II, Div. 2, Groups F and G; Class III, Div. 2.	Temperature Class T4A at 40°C and T4 at 85°C maximum ambient.	F (IAP10 only)
FM zone certified intrinsically safe AEx ia IIC.	Temperature Class T4 at 85°C maximum ambient.	F (IAP10 only)
FM intrinsically safe for Class I, Div. 1, Groups A, B, C, and D; Class II, Div. 1, Groups E, F, and G; Class III, Div. 1.	Temperature Class T4A at 40°C and T4 at 85°C maximum ambient.	R (IGP10 only)
FM nonincendive for Class I, Div. 2, Groups A, B, C, and D; Class II, Div. 2, Groups F and G; Class III, Div. 2.	Temperature Class T4A at 40°C and T4 at 85°C maximum ambient.	R (IGP10 only)
FM zone certified intrinsically safe AEx ia IIC.	Temperature Class T4 at 85°C maximum ambient.	R (IGP10 only)

MODEL CODE

MODEL CODE

<u>Description</u>				<u>Model</u>
Gauge Pressure Transmitter with Pulp and Paper Process Connections				IGP10
Absolute Pressure Transmitter with Pulp and Paper Process Connections				IAP10
<u>Electronics Versions and Output Signal</u>				
Intelligent; Digital FoxCom and 4 to 20 mA dc, Configurable				-D
Intelligent; Digital HART and 4 to 20 mA				-T
Intelligent; Digital Foundation fieldbus				-F
Electronic; 4 to 20 mA Analog Output				-A
Electronic; 1 to 5 V dc Analog Output, Low Power				-V
<u>Structure Code – Materials, Fill Fluid, and Process Connection Type</u>				
Connection Material	Diaphragm Material	Fill Fluid	Process Connection Type (a)	
316L ss	316L ss	Silicone	Sleeve Type, 1-inch nominal	PA
316L ss	316L ss	Silicone	Threaded Type, 1-inch nominal	PB
316L ss	316L ss	Silicone	Sleeve Type, 1 1/2-inch nominal	PC
316L ss	316L ss	Silicone	Threaded Type, 1 1/2-inch nominal	PD
316L ss	Nickel alloy (b)	Silicone	Sleeve Type, 1-inch nominal	PE
316L ss	Nickel alloy (b)	Silicone	Threaded Type, 1-inch nominal	PF
316L ss	Nickel alloy (b)	Silicone	Sleeve Type, 1 1/2-inch nominal	PG
316L ss	Nickel alloy (b)	Silicone	Threaded Type, 1 1/2-inch nominal	PH
316L ss	Nickel alloy (b)	Silicone	Threaded Type, 1 1/2-inch nominal (fits Ametek spud)	PJ
<u>Span Limits – Absolute or Gauge Pressure Units, as applicable</u>				
kPa	inH₂O	mbar	Used with:	
0.87 and 50	3.5 and 200	8.7 and 500	IGP10 only (c)	B (c)
MPa	psi	bar or kg/cm²	Used with:	
0.007 and 0.21	1 and 30	0.07 and 2.1	IAP10 and IGP10	C
0.07 and 2.1	10 and 300	0.7 and 21	IAP10 and IGP10	D
<u>Conduit Connection and Housing Material</u>				
1/2 NPT Conduit Connection, Both Sides, Aluminum Housing				1
PG 13.5 Conduit Connection, Both Sides, Aluminum Housing (with Electrical Safety Codes E, M, and N only)				2
1/2 NPT Conduit Connection, Both Sides, 316 ss Housing				3
PG 13.5 Conduit Connection, Both Sides, 316 ss Housing (with Electrical Safety Codes E, M, and N only)				4
M20 Conduit Connection, Both Sides, Aluminum Housing (with Electrical Safety Codes E, M, and N only)				5
M20 Conduit Connection, Both Sides, 316 ss Housing (with Electrical Safety Codes E, M, and N only)				6
<u>Electrical Safety (See Electrical Safety Specifications Section for Description)</u>				
ATEX II 1 GD, EEx ia IIC, or II 1/2 GD, EEx ib IIC (with Versions D and T only)				E
ATEX FISCO II 1 GD, EEx ia IIC (with Electronics Version -F only)				E
ATEX II 3 GD, EEx nL IIC (with Versions D and T only)				N
ATEX FNICO II 3 GD, EEx nL IIC (with Version F only)				N
ATEX Multiple Certifications (customer marks data plate) (includes ATEX Codes E and N)				M

MODEL CODE (CONTINUED)

Description	Electronic Version					Model
Description	A	D	F	T	V	
CSA Certifications for IAP10 only						C
Intrinsically Safe		X			X	
Explosionproof	X	X	X	X	X	
Class I, II, III; Div. 2	X	X	X	X	X	
Zone Certified: Ex ia IIC; Ex nA II			X	X	X	
FISCO Intrinsically Safe			X			
FNICO, Class I, II, III, Div. 2			X			
CSA Certifications for IGP10 only						L
Intrinsically Safe		X			X	
Class I, II, III; Div. 2	X	X	X	X	X	
Zone Certified: Ex ia IIC; Ex nA II			X	X	X	
FISCO Intrinsically Safe			X			
FNICO, Class I, II, III, Div. 2			X			
FM Certifications for IAP10 only						F
Intrinsically Safe		X		X	X	
Explosionproof	X	X	X	X	X	
Nonincendive; Div. 2	X	X	X	X	X	
Zone Approved: AEx ia IIC			X	X	X	
FISCO Intrinsically Safe			X			
FNICO, Class I, II, III, Div. 2			X			
FM Certifications for IGP10 only						R
Intrinsically Safe		X			X	
Nonincendive; Div. 2	X	X	X	X	X	
Zone Approved: AEx ia IIC			X	X	X	
FISCO Intrinsically Safe			X			
FNICO, Class I, II, III, Div. 2			X			
IECEx Certifications:						T
FISCO, Ex ia IIC (with Electronic Version -F only) Intrinsically Safe, Ex ia IIC (with Electronic Version -T only)						
IECEx Certifications:						U
FNICO, Ex nL IIC (with Electronic Version -F only) Protection n, Ex nL IIC (with Electronic Version -T only)						

MODEL CODE (CONTINUED)

Description	Model
Multi-marked for ATEX, CSA, and FM Intrinsically Safe Applications (HART only) (d)	W
Optional Selections - See Descriptions below	
Digital Indicator with Pushbuttons or Blind Solid Cover over Standard LCD Indicator	
Digital Indicator, Pushbuttons, and Window Cover, Electronic Versions -D, -F, and -T only	-L1
Blind (Solid Cover) is substituted for Glass Window Cover, Electronic Versions -A and -V only	-L2
Conduit Thread Adapters (Not available with Conduit Connection Codes 5 and 6)	
Hawke-Type 1/2 NPT Cable Gland for use with Conduit Connection Codes 1 and 3 (e) (f)	-A1
Plastic PG 13.5 Cable Gland for use with Conduit Connection Codes 2 and 4 (e)	-A2
M20 Connector for use with Conduit Connection Codes 1 and 3 (f)	-A3
Brass PG 13.5 Cable Gland (Trumpet-Shaped) for use with Conduit Connection Codes 2 and 4 (e)	-A4
Electronics Housing Features	
External Zero Adjustment	-Z1
Custody Transfer Lock and Seal	-Z2
External Zero Adjustment and Custody Transfer Lock and Seal	-Z3
Custom Factory Configuration	
Digital Output (4 to 20 mA Default if not selected) - available with Electronics Version -D only	-C1
Full Factory Configuration (Requires Configuration Form to be filled out)	-C2
SIL2 Transmitters for HART Versions Only	
SIL2-Certified HART Transmitter	-S2
Instruction Books (Common MI, Brochure, and Full Documentation Set on DVD is Standard)	
Without Instruction Book and DVD - Only "Getting Started" Brochure is supplied	-K1
Miscellaneous Optional Selections	
Supplemental Customer Tag (Stainless Steel Tag wired onto Transmitter)	-T
EXAMPLE: IGP10-DPAC1N-L1Z2C1	

- a. All spuds (mounting ferrules) are accessories that are specified by part number. All necessary mounting parts and gaskets to attach the transmitter to the spud are supplied with the transmitter. See "ACCESSORIES" table.
- b. Equivalent to Hastelloy® C-276.
- c. Span Limit Code B is available only with IGP10 Gauge Pressure Transmitters that have Structure Codes PC, PD, PG, PH, or PJ (1 1/2 in process connectors). As indicated in the Model Code under Span Limits, the IAP10 Transmitter is not used with Span Limit Code B.
- d. Refer to Electrical Safety Specifications section for multi-marking details.
- e. Available with Electrical Safety Code E only.
- f. Available with Electrical Safety Codes E, M, and N only.

ACCESSORIES

Weld Spuds, Heat Sink/Plugs, Calibration Adapters, and O-Rings/Gaskets

Accessories are ordered and supplied separately.

See “DIMENSIONS-NOMINAL” section for configuration and dimensions of accessories listed.

Description of Accessory	Used with Structure Code	Part Number
For use with 1-inch Sleeve Type Connector Weld Spud (a) Calibration Adapter (a) Process O-Ring at Diaphragm (Viton), 1-in Sleeve (b) Process O-Ring, Outer (Viton), 1-in Sleeve (b)	PA, PE PA, PE PA, PE PA, PE	N1214LH N1214MP N1214YY N1214YZ
For use with 1-inch Flush, Threaded Type Connector Weld Spud (a) (c) Heat Sink/Plug (a) (c) Calibration Adapter (a) Process Gasket (Gylon) (b)	PB, PF PB, PF PB, PF PB, PF	N1214XW N1214YS N1214XX N1214YX
For use with 1.5-inch Sleeve Type Connector Weld Spud (a) Calibration Adapter (a) Process O-Ring (Viton) (b)	PC, PG PC, PG PC, PG	N1214MM N1214MQ N1214YW
For use with 1.5-inch Flush, Threaded Type Connector Weld Spud (a) (c) Heat Sink/Plug (a) (c) Calibration Adapter (a) Process Gasket (Gylon) (b)	PD, PH PD, PH PD, PH PD, PH	N1214LG N1214YR N1214MN N1214YV
For use with 1.5-inch Threaded Type Connector for Ametek Spud Weld Spud (a) (c) Heat Sink/Plug (a) (c) Calibration Adapter (a) Process Gasket (Gylon) (b)	PJ PJ PJ PJ	N1216AM N1216AP N1216AN N1216AQ

- a. Weld spuds, heat sinks/plugs, and calibration adapters are supplied by user.
- b. Each transmitter is shipped with its required gaskets or O-rings. Part number is for a package of five O-rings or gaskets. This package of gaskets/O-rings is recommended as extras or spares.
- c. When ordering a weld spud for use with a threaded type connector, note that the use of a heat sink/plus is required to prevent metal distortion due to the high temperature of the welding process.

SUGGESTED RFQ SPECIFICATIONS

The manufacturer shall provide direct connected gauge or absolute pressure transmitters that transmit a digital or analog output signal for use in a standard two-wire dc supply voltage system. The transmitter shall have integral process connectors for use in pulp and paper processes. Specifications for these transmitters are as follows:

Digital Output Signal:	FoxCom digital and/or 4 to 20 mA dc output signal; HART digital signal superimposed on a 4 to 20 mA output signal; FOUNDATION fieldbus (FISCO/FNICO) digital signal, 31.25 kbits/s
Analog Output Signal:	4 to 20 mA dc, or 1 to 5 V dc (low power)
Remote Communications:	FoxCom, HART, or FISCO/FNICO compliant Fieldbus remote communications must not interfere with the output signal.
RFI Protection:	0.1% error between 27 and 1000 MHz at 10 V/m field intensity
Span Limits:	IAP10: from 0.007 to 2.1 MPa (1 to 300 psi) IGP10: from 0.87 kPa to 2.1 MPa (3.5 inH ₂ O to 300 psi)
Proof Pressure:	1.5 times Full Scale Pressure Range
Process Connectors:	Direct to process piping or tank spud: <ul style="list-style-type: none"> ▶ 1- and 1 1/2-in Sleeve Type ▶ 1- and 1 1/2-in Threaded Type ▶ 1 1/2-in Threaded Type to fit a 1 1/2-in Ametek spud.
Diaphragm Materials:	316L ss or nickel alloy (a)
Housing:	316 ss, or Aluminum housing with Epoxy finish
Electronics:	Enclosed in a NEMA 4X (IEC IP66) housing sealed with O-rings for double protection against moisture or other contaminants. Integral LCD Digital Indicator with on-board configuration pushbuttons; standard with analog output transmitters, and optional with digital output transmitters.
Approximate Mass:	With Aluminum Housing: Less than 2 kg (4.5 lb), depending on process connection used. With 316 ss Housing: Add 1.1 kg (2.4 lb) With LCD Indicator: Add 0.2 kg (0.4 lb)
Model Code:	Foxboro I/A Series IGP10/IAP10 Direct Connected, Gauge or Absolute Pressure Transmitter having an integral process connector for pulp and paper processes; with FoxCom Communication Protocol, HART Communication Protocol, FISCO and FNICO compliant FOUNDATION Fieldbus Communication Protocol, 4 to 20 mA dc Analog Output Signal, or a Low Power Transmitter with a 1 to 5 V dc Analog Output Signal, or equivalent

a. Equivalent to Hastelloy® C-276.

DIMENSIONS-NOMINAL

**IGP10 AND IAP10 TRANSMITTERS FOR PULP AND PAPER PROCESSES
WITH SLEEVE TYPE CONNECTORS**

**mm
in**

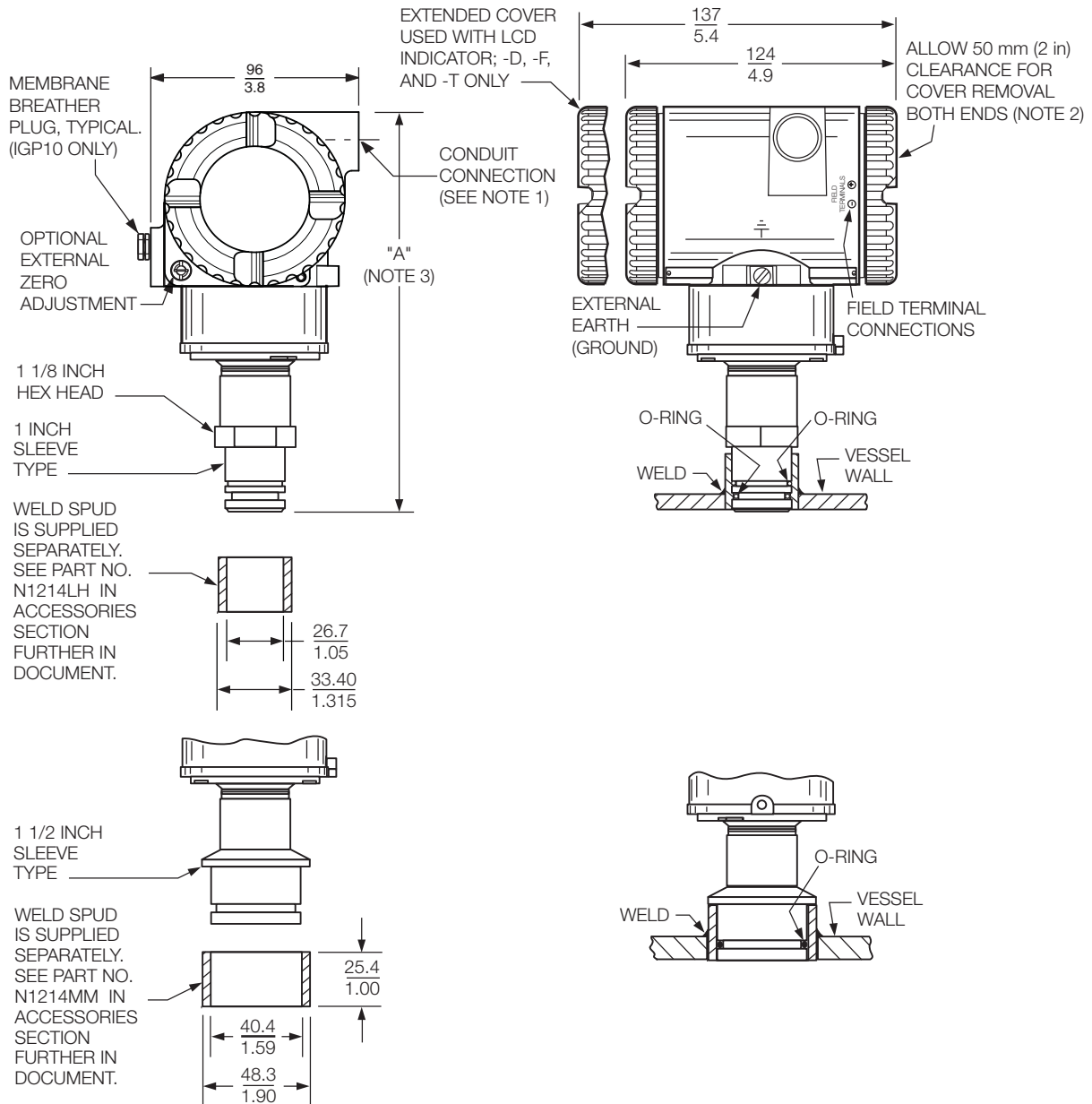

NOTES

1. Conduit connection 1/2 NPT, PG 13.5, or M20, both sides: plug unused connection with metal plug (supplied).
2. Topworks rotatable to any position within one full turn counterclockwise of fully tightened position.
3. Overall height: Dimension "A" is 185 mm (7.3 in) for the 1 inch sleeve type; and 180 mm (7.1 in) for the 1 1/2 inch sleeve type.

IGP10 AND IAP10 TRANSMITTERS FOR PULP AND PAPER PROCESSES
WITH THREADED TYPE PROCESS CONNECTORS

mm
in

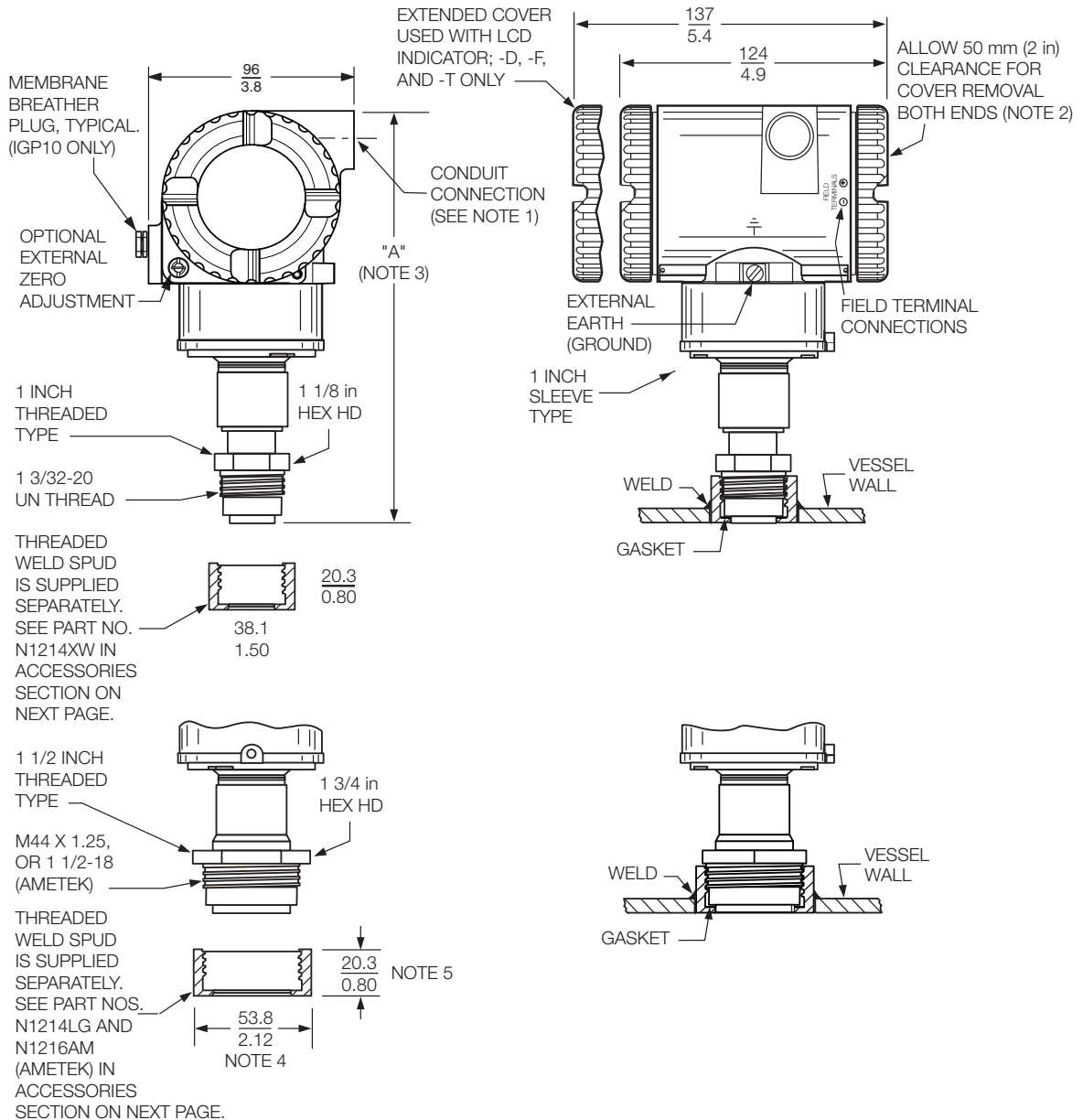

NOTES

1. Conduit connection 1/2 NPT, PG 13.5, or M20, both sides: plug unused connection with metal plug (supplied).
2. Topworks rotatable to any position within one full turn counterclockwise of fully tightened position.
3. Overall height: Dimension "A" is 190 mm (7.5 in) for the 1 in threaded type; and 182 mm (7.2 in) for the 1 1/2 inch threaded type.
4. 50.5 mm (1.99 in) for Ametek weld spud.
5. 25.4 mm (1.00 in) for Ametek weld spud.

ACCESSORIES

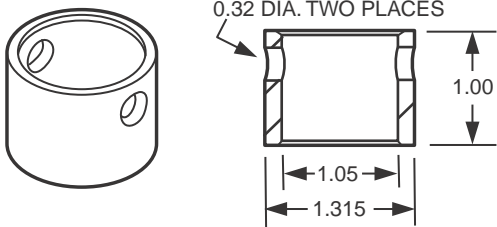
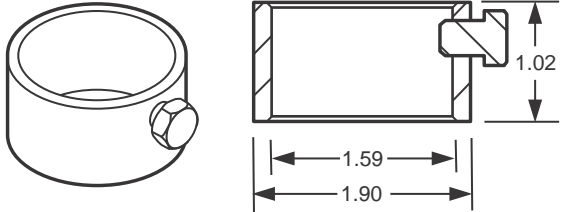
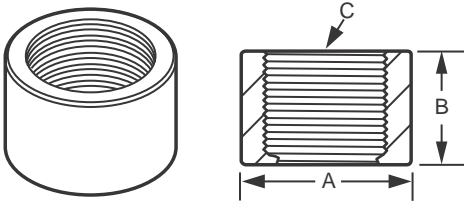
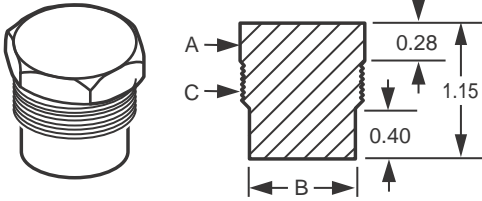
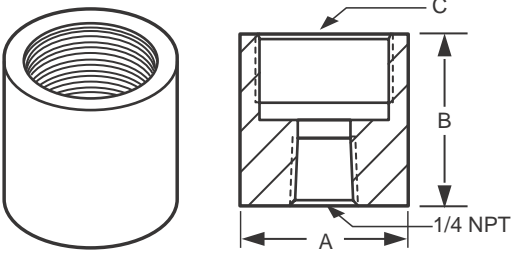
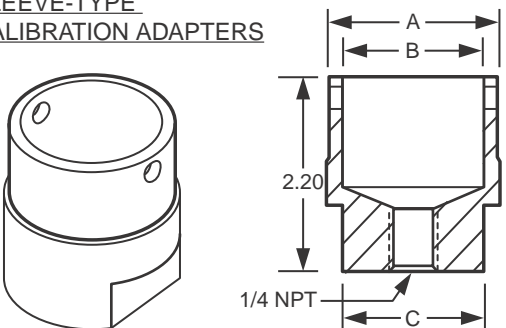
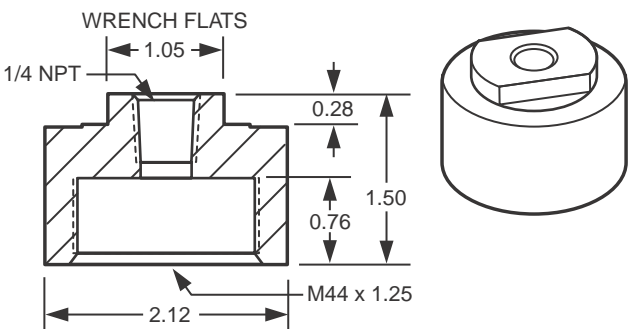
<p><u>WELD SPUD - N1214LH</u> for Structure Codes PA, PE</p> 	<p><u>WELD SPUD - N1214MM</u> for Structure Codes PC, PG</p> 																				
<p><u>WELD SPUDS</u></p> <table border="1" style="width:100%; border-collapse: collapse;"> <thead> <tr> <th>Part No.</th> <th>A</th> <th>B</th> <th>C (Thread)</th> <th>Struct. Code</th> </tr> </thead> <tbody> <tr> <td>N1214XW</td> <td>1.50</td> <td>0.80</td> <td>1 3/32-20</td> <td>PB, PF</td> </tr> <tr> <td>N1214LG</td> <td>2.38</td> <td>0.80</td> <td>M44 x 1.25</td> <td>PD, PH</td> </tr> <tr> <td>N1216AM</td> <td>1.99</td> <td>1.00</td> <td>1 1/2-18</td> <td>PJ</td> </tr> </tbody> </table> <p>Must be used with heat sinks/plugs (below) to prevent metal distortion due to high temperature of welding process</p> 		Part No.	A	B	C (Thread)	Struct. Code	N1214XW	1.50	0.80	1 3/32-20	PB, PF	N1214LG	2.38	0.80	M44 x 1.25	PD, PH	N1216AM	1.99	1.00	1 1/2-18	PJ
Part No.	A	B	C (Thread)	Struct. Code																	
N1214XW	1.50	0.80	1 3/32-20	PB, PF																	
N1214LG	2.38	0.80	M44 x 1.25	PD, PH																	
N1216AM	1.99	1.00	1 1/2-18	PJ																	
<p><u>HEAT SINKS/PLUGS</u></p> <table border="1" style="width:100%; border-collapse: collapse;"> <thead> <tr> <th>Part No.</th> <th>A</th> <th>B</th> <th>C (Thread)</th> <th>Struct. Code</th> </tr> </thead> <tbody> <tr> <td>N1214YS</td> <td>1.125</td> <td>1.000</td> <td>1 3/32 - 20</td> <td>PB, PF</td> </tr> <tr> <td>N1214YR</td> <td>1.75</td> <td>1.595</td> <td>M44 x 1.25</td> <td>PD, PH</td> </tr> <tr> <td>N1216AP</td> <td>1.75</td> <td>1.595</td> <td>1 1/2-18</td> <td>PJ</td> </tr> </tbody> </table> <p>Must be used with weld spuds (above) to prevent metal distortion due to high temperature of welding process</p> 		Part No.	A	B	C (Thread)	Struct. Code	N1214YS	1.125	1.000	1 3/32 - 20	PB, PF	N1214YR	1.75	1.595	M44 x 1.25	PD, PH	N1216AP	1.75	1.595	1 1/2-18	PJ
Part No.	A	B	C (Thread)	Struct. Code																	
N1214YS	1.125	1.000	1 3/32 - 20	PB, PF																	
N1214YR	1.75	1.595	M44 x 1.25	PD, PH																	
N1216AP	1.75	1.595	1 1/2-18	PJ																	
<p><u>THREADED-TYPE CALIBRATION ADAPTERS</u></p> <table border="1" style="width:100%; border-collapse: collapse;"> <thead> <tr> <th>Part No.</th> <th>A</th> <th>B</th> <th>C (Thread)</th> <th>Struct. Code</th> </tr> </thead> <tbody> <tr> <td>N1214XX</td> <td>1.50</td> <td>1.50</td> <td>1 3/32-20</td> <td>PB, PF</td> </tr> <tr> <td>N1216AN*</td> <td>1.99</td> <td>1.75</td> <td>1 1/2-18</td> <td>PJ</td> </tr> </tbody> </table> <p>*For Ametek spud</p> 		Part No.	A	B	C (Thread)	Struct. Code	N1214XX	1.50	1.50	1 3/32-20	PB, PF	N1216AN*	1.99	1.75	1 1/2-18	PJ					
Part No.	A	B	C (Thread)	Struct. Code																	
N1214XX	1.50	1.50	1 3/32-20	PB, PF																	
N1216AN*	1.99	1.75	1 1/2-18	PJ																	
<p><u>SLEEVE-TYPE CALIBRATION ADAPTERS</u></p>  <table border="1" style="width:100%; border-collapse: collapse;"> <thead> <tr> <th>Part No.</th> <th>A</th> <th>B</th> <th>C</th> <th>Struct. Code</th> </tr> </thead> <tbody> <tr> <td>N1214MG</td> <td>1.90</td> <td>1.60</td> <td>1.62</td> <td>PA, PE</td> </tr> <tr> <td>N1216MP</td> <td>1.315</td> <td>1.05</td> <td>1.05</td> <td>PC, PG</td> </tr> </tbody> </table>	Part No.	A	B	C	Struct. Code	N1214MG	1.90	1.60	1.62	PA, PE	N1216MP	1.315	1.05	1.05	PC, PG	<p><u>THREADED-TYPE CALIBRATION ADAPTER - N1214MN</u> For Structure Codes PD, PH</p> 					
Part No.	A	B	C	Struct. Code																	
N1214MG	1.90	1.60	1.62	PA, PE																	
N1216MP	1.315	1.05	1.05	PC, PG																	

NOTES

ORDERING INSTRUCTIONS

1. Model Number.
2. Calibrated Pressure Range using pressure units from Table 1.
3. Configuration Data Form when Factory Configuration Option -C2 is specified.
4. Process Connection Accessories (see "ACCESSORIES" section).
5. If Option -S2 (SIL-Certified HART Transmitter) is selected, a copy of the certification can be provided by specifying AS Code CERT-S.
6. Other Transmitter Options and Accessories not in Model Code; see PSS 2A-1Z9 E.
7. User Tag Data - Data Plate: 32 characters maximum.
For additional tag data, specify optional Customer Tag -T.
8. User Tag Data - Software (Database);
 - ▶ Version -D: 12 characters maximum.
 - ▶ Version -T: 8 characters maximum.
 - ▶ Version -F: 32 characters maximum.
 - ▶ Versions -A and -V: not applicable.

OTHER FOXBORO PRODUCTS

The Foxboro product lines offer a broad range of measurement and instrument products, including solutions for pressure, flow, analytical, temperature, positioning, controlling, and recording.
For a list of these offerings, visit our web site at:

www.fielddevices.foxboro.com