

Models IAP10S and IGP10S Absolute and Gauge Pressure Transmitters with HART[®] Communication Protocol



IAP10S/IGP10S
Transmitter
Flameproof Structure Codes
52, 53, 60-63, 90-93, D5, D6,
S5, S6, SH, and SJ

IAP10S/IGP10S
Transmitter
Structure Codes 20-23, 30-33
34-39, 42-47, 70-83, D1, D2,
S3, S4, SC, and SD

The Foxboro[®] Pressure S Series Models IAP10S and IGP10S transmitters are intelligent, two-wire transmitters that provide precise, reliable measurement of absolute or gauge pressure, and transmit a 4 to 20 mA output signal with a superimposed HART[®] digital signal for remote configuration and monitoring.

FEATURES

- ▶ 100 mS response time
- ▶ Unique patented FoxCal™ feature maintains published accuracy without the need for field calibration, down to 30:1 turndown, by using multiple factory-present calibrated ranges.
- ▶ Time in Service meter features cumulative power-up time and time powered since last user reset.
- ▶ Field-proven piezoresistive silicon microsensors.
- ▶ Simple, elegant sensor packaging with very few parts; achieves exceptionally high reliability.
- ▶ Durable aluminum or 316 ss housing options available; both meet NEMA 4X and IEC IP67 ratings.
- ▶ Remote configuration capability via a HART communicator or PC-based configurator; local configuration capability via an optional LCD indicator with on-board pushbuttons.
- ▶ 1/2 NPT male and female threaded process connection.
- ▶ Numerous configurations of direct connect or remote mount seals available.
- ▶ HART 6 protocol allows multidrop topology.
- ▶ Sensor diaphragm materials include Co-Ni-Cr, 316L ss, and nickel alloy⁽¹⁾. All diaphragm materials are available with gold plating.
- ▶ CE marked; complies with applicable EMC, ATEX, and PED European Union Directives.

1. Equivalent to Hastelloy[®]. Hastelloy is a registered trademark of Haynes International, Inc.

- ▶ Multi-marking available for ATEX, CSA, and FM intrinsically safe applications.
- ▶ Complies with NAMUR NE 21 interference immunity requirement, and NAMUR NE 43 analog output overrange and underrange annunciations.
- ▶ Complies with electromagnetic compatibility requirements of European EMC Directive 2004/108/EC by conforming to following EN and IEC Standards: EN 61326-1, and IEC 61000-4-2 through 61000-4-6.
- ▶ Meet numerous requirements for hazardous locations. Versions available to meet Agency flameproof and zone requirements.
- ▶ Dual Seal certified by CSA to meet ANSI/ ISA 12.27.01-2003 requirements.
- ▶ Numerous mounting bracket set options.
- ▶ Standard 5-year warranty.

HART COMMUNICATION PROTOCOL VERSION -T ELECTRONICS

4 to 20 mA with HART 6 communications. Allows direct analog connection to common receivers while still providing full digital communications using a HART communicator, PC-based configurator, or optional LCD indicator.

HART INTELLIGENT MODULE CONFIGURED FOR 4 TO 20 mA OUTPUT

Measurements and diagnostics are available from the HART communicator connected to the two-wire loop carrying the 4 to 20 mA measurement signal by using a bidirectional digital signal superimposed on the 4 to 20 mA current signal.

Multiple measurements are transmitted digitally, including not only the pressure measurement, but also the electronics temperature and sensor temperature, which can be used to monitor external heat tracing equipment. Complete transmitter diagnostics are also communicated.

Configuration and reranging can be accomplished with a HART communicator, PC-based configurator, or the optional LCD indicator with pushbuttons.

TIME IN SERVICE METER

Similar to how an odometer allows an automobile owner to track the total number of miles driven and a trip odometer tracks the number of miles driven since a user-defined starting point, the IAP10S/IGP10S transmitters allow you to keep track of the number of days the transmitter has been in service. The Time In Service meter tracks both the total number of days the transmitter has been powered up in the field over its lifetime (total days), and also tracks the number of days the transmitter has been powered up since the last Time in Service meter reset (user days). You can reset the user days value to zero using a HART communicator, a PC-based configurator, or the optional local indicator, but you cannot reset the lifetime service parameter.

WIDE RANGEABILITY

Three absolute pressure versions are offered to allow spans from 0.5 to 2000 psi (0.0034 to 13.8 MPa), and four gauge pressure versions are offered to allow spans from 0.3 to 6000 psi (0.002 to 41.4 MPa).

WIDE TURNDOWN RANGES

Excellent performance is maintained over a wide turndown range, meaning that an IAP10S/IGP10S transmitter performs as well as, or better than, two separate transmitters designed to cover the same turndown range.

The turndown ratio for span adjustment is up to 400:1. This means that the IGP10S transmitter with its 200 psi URL sensor can be set to provide a 4 to 20 mA output for any range between 0 to 0.5 and 0 to 200 psi (0 to 0.0034 and 0 to 1.38 MPa). Similarly, the IGP10S transmitter with its 2000 psi URL sensor covers any range between 0 to 5 and 0 to 2000 psi (0 to 0.034 and 0 to 13.8 MPa).

Accuracy of $\pm 0.060\%$ of span is maintained for a span adjustment turndown range of up to 80:1 for E and F range transmitters.

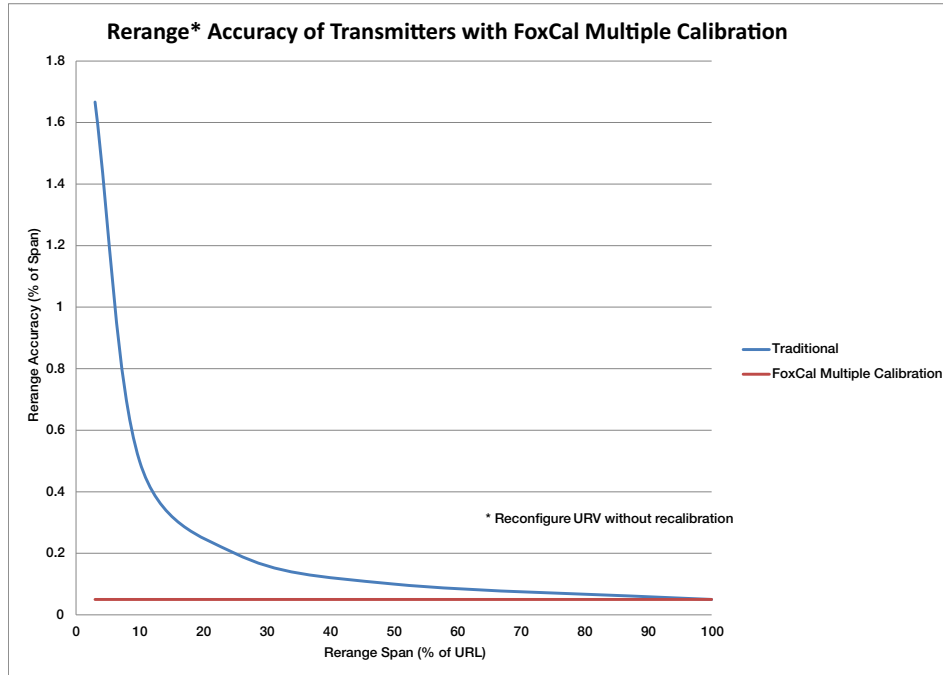

PATENTED FoxCal™ TECHNOLOGY

The Foxboro S Series gauge and absolute pressure transmitters offer the FoxCal™ multiple calibration feature, which eliminates the need for a traditional single span calibration at an application-specific pressure range. Transmitters with the FoxCal feature enabled use multiple calibrated ranges that are stored in on-board memory. The calibrated ranges are preset in the factory and cover the full pressure range of the transmitter. During operation, a real-time, seamless transition from one calibrated range to another maintains digital accuracy as a percent of reading from 3% to 100% of the upper range limit (URL).

Factory calibration and field calibration for specific applications are not required for zero-based ranges up to 30:1 turndown. You can simply configure or Rerange the upper range value (URV) without performing a recalibration at the URV. You will only need to perform a zero adjustment after installation to obtain performance to the specified reference accuracy.

OPTIONAL CALIBRATION CERTIFICATE

Optionally, you can request a calibration certificate with your IAP10S or IGP10S transmitter, which provides verification that the transmitter meets the reference accuracy specification within a user specified range.

For transmitters shipped with the FoxCal feature enabled and the Calibration Certificate option selected, the transmitters are not recalibrated to the user specified range. The LRV and URV points are configured (Reranged) to the user specified values and the accuracy is verified over that specific range.

CUSTOM FACTORY CALIBRATION

A custom two-point factory calibration is also available as a model code option. This option is useful if your application requires non-zero based ranges with greater than 10:1 turndown, zero-based ranges with greater than 30:1 turndown, or when mandated by a specific requirement. When a transmitter is shipped with the custom factory calibration option, the FoxCal feature is automatically disabled and a traditional two-point calibration is performed.

HIGH PERFORMANCE

Both transmitters utilize microprocessor-based correction to achieve both excellent accuracy and ambient temperature compensation.

MULTIDROP COMMUNICATIONS

Point-to-point or multidrop topologies are permitted. Multidrop communication is the connection of several transmitters to a single communications line. Communication between the host computer and transmitters takes place digitally with the analog output of the transmitter fixed. Up to fifteen transmitters can be connected on a single twisted pair of wires or over leased telephone lines. See Figure 6 and Figure 7.

WIDE VARIETY OF MATERIALS

With process connection of 316L ss or nickel alloy⁽²⁾, and sensor diaphragm available in either 316L ss, nickel alloy⁽²⁾, or highly corrosion resistant Cobalt-Nickel-Chrome (Co-Ni-Cr), this transmitter is an excellent choice for the vast majority of process pressure measurements.

EASE OF INSTALLATION

These transmitters are light weight and easy-to-install.

Rotatable Topworks allows transmitter installation in tight places, allows indicator to be positioned in preferred direction, and eases field retrofit.

Two Conduit Entrances offer a choice of entry positions for ease of installation and self-draining of condensation regardless of mounting position and topworks rotation.

Wiring Guides and Terminations provide ease of wire entry and support, plenty of space to work and store excess wire, and large, rugged screw terminals for easy wire termination.

OPTIONAL LCD DIGITAL INDICATOR

This is a two-line digital indicator with on-board pushbuttons that displays the measurement with a choice of units. The pushbuttons allow zero and span adjustments, as well as local configuration without the need for a HART communicator or PC-based configurator. See Figure 8.

EXCEPTIONAL VALUE

The combination of small size, light weight, direct mounting, standard materials, and wide measurement capability with high performance make this an exceptionally cost effective solution for process pressure measurement.

DIRECT PROCESS MOUNTING

These light weight transmitters with their 1/2 NPT male and female threaded connections can be installed directly on process piping without mounting brackets. Optional mounting brackets are also offered for unique mounting requirements.

FLAMEPROOF DESIGN

The IAP10S and IGP10S flameproof versions are designed to meet Agency flameproof and zone requirements.

Figure 1. Direct Connected Transmitter (Flameproof Version Shown on Left)



2. Equivalent to Hastelloy® C-276.

PRESSURE SEALS

Pressure seals are used with the IAP10S and IGP10S Series Transmitters when it is necessary to keep the transmitter isolated from the process. A sealed system is used for a process fluid that may be corrosive, viscous, subject to temperature extremes, toxic, sanitary, or tend to collect and solidify.

Table 1 lists the various seals that can be used with these transmitters. To order a transmitter with seals, both a Transmitter Model Number and Seal Model Number are required. See PSS 2A-1Z11 A for a complete listing of pressure seal models and specifications. Also see Figure 2 for typical pressure seal configurations.

Table 1. Pressure Seals Used with IAP10S and IGP10S Transmitters

Direct Connect Pressure Seal Assemblies		
Seal Model	Seal Description	Process Connections
PSFAD	Flanged, Direct Connect, Recessed Diaphragm	ANSI Class 150/300/600/1500 flanges
PSFFD	Flanged, Direct Connect, Flush Diaphragm	ANSI Class 150/300/600 and PN 10/40
PSTAD	Threaded, Direct Connect, Recessed Diaphragm	1/4, 1/2, 3/4, 1, or 1 1/2 NPT internal thread
PSISD	In-Line Saddle Weld, Direct Connect, Recessed Diaphragm	Lower housing of seal is in-line saddle welded to nominal 3- or 4-inch (and larger) pipe
PSFPS	Flanged, Remote Mount, Flush Diaphragm	ANSI Class 150/300/600 flanges and BS/DIN PN 10/40 flanges
PSFES	Flanged, Remote Mount, Extended Diaphragm	ANSI Class 150/300/600 flanges and BS/DIN PN 10/40, 10/16, 25/40 flanges
PSFAR	Flanged, Remote Mount, Recessed Diaphragm	ANSI Class 150/300/600/1500 flanges
PSFFR	Flanged, Remote Mount, Flush Diaphragm	ANSI Class 150/300/600 flanges and DIN/BS PN 10/40
PSTAR	Threaded, Remote Mount, Recessed Diaphragm	1/4, 1/2, 3/4, 1, or 1 1/2 NPT internal thread
PSISR	In-Line Saddle Weld, Remote Mount, Recessed Diaphragm	Lower housing of seal is in-line saddle welded to nominal 3- or 4-inch (and larger) pipe
PSSCR	Sanitary, Remote Mount, Flush Diaphragm	Process Connection secured with a Tri-Clamp to a 2- or 3-inch pipe
PSSSR	Sanitary, Remote Mount, Extended Diaphragm	Process Connection to 2-in Mini Spud or 4-in Standard Spud; Tri-Clamp

Figure 2. Typical Pressure Seals used with IAP10S and IGP10S Transmitters



FUNCTIONAL SPECIFICATIONS

Table 2. Normal Operating Span and Span Limits for IAP10S and IGP10S Transmitters

Model	Span Limit Code	Normal Operating Span (a)			Span Limits (a)		
		psi	MPa	bar	psi	MPa	bar
IAP10S	D	6.67 to 200	0.046 to 1.38	0.46 to 13.8	0.5 and 200	0.0034 and 1.38	0.034 and 13.8
	E	25 to 2000	0.17 to 13.8	1.7 to 138	5 and 2000	0.034 and 13.8	0.34 and 138
IGP10S	D	6.67 to 200	0.046 to 1.38	0.46 to 13.8	0.5 and 200	0.0034 and 1.38	0.034 and 13.8
	E	25 to 2000	0.17 to 13.8	1.7 to 138	5 and 2000	0.034 and 13.8	0.34 and 138
	F (b)	75 to 6000	0.52 to 41.4	5.2 to 414	75 and 6000	0.52 and 41.4	5.2 and 414

a. In absolute or gauge pressure units, as applicable.

b. Not available with pressure seals.

Table 3. Maximum Overage and Proof Pressure Ratings

Span Limit Code	Maximum Overage Pressure Rating (a)		Proof Pressure Rating (a) (b)	
	psi	MPa	psi	MPa
D	300	2.1	800	5.51
E	3000	20.7	8000	55.1
F (IGP10S only)	8400	58	24000	165

a. Values listed are in absolute or gauge pressure units, as applicable. Maximum overrange pressure is the maximum pressure that may be applied without causing damage to the transmitter.

b. Proof pressure ratings meet ANSI/ISA Standard S82.03-1988. Unit may become nonfunctional after application of proof pressure.

Output Signal and Configuration

Output is 4 to 20 mA with digital HART communications. For multidrop applications, the mA signal is fixed at 4 mA to provide power to the device. Configurable using the HART communicator, PC-based configurator, or optional LCD indicator with on-board pushbuttons.

Electronics and Sensor Temperatures

Electronics and sensor temperatures are readable from the HART communicator or PC-based configurator. This measurement corresponds to the transmitter temperature at the sensor and electronic module; it is not necessarily the process temperature.

Field Wiring Reversal

Accidental reversal of field wiring will not damage the transmitter, provided the current is limited to 1 A or less by active current limiting or loop resistance. Sustained currents of 1 A will not damage the electronics module or sensor, but could damage the terminal block assembly and external instruments in the loop.

Suppressed Zero

Suppressed zero ranges are acceptable as long as the Span and Range Limits are not exceeded.

Zero and Span Adjustments

Zero and span adjustments can be initiated using a HART communicator, a PC-based configurator, or the optional LCD indicator with on-board pushbuttons.

Write Protect Jumper

The transmitter has a write protect jumper that can be positioned to lock out all configurators from making transmitter database changes. This makes the transmitter suitable for Safety Shutdown System Applications that require this feature.

Supply Voltage Requirements and External Loop Load Limitations

Nominal minimum supply voltage is 11.5 V dc. This value can be reduced to 11 V dc by using a plug-in jumper across the test receptacles in the field wiring compartment terminal block as shown in the Physical Specifications section.

Figure 3. 4 to 20 mA Output, Supply Voltage vs. Output Load

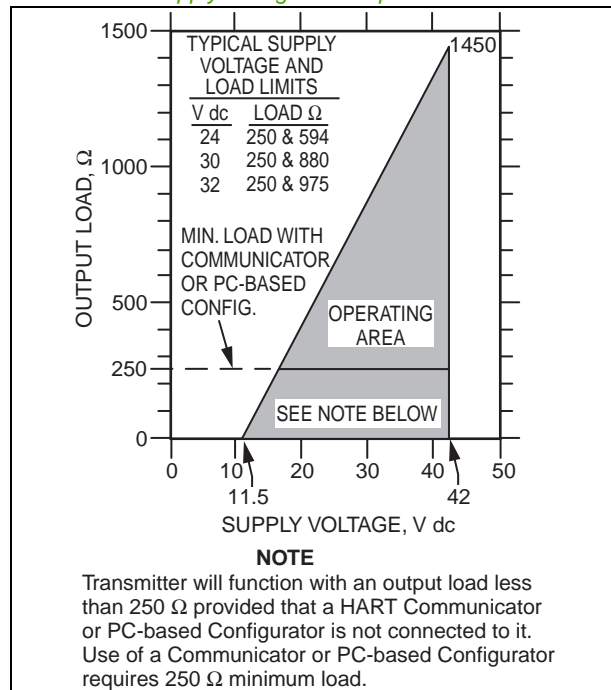

Zeroing for Nonzero-Based Ranges

Dual Function Zeroing allows zeroing with the transmitter open to atmosphere, even when there is a nonzero-based range. This greatly simplifies position effect zeroing on many pressure and level applications. It applies to the LCD Indicator pushbuttons and optional External Zero Adjustment.

Adjustable Damping

Damping is user-selectable to values of 0, 0.25, 0.5, 1, 2, 4, 8, 16, or 32 seconds.

NOTE

Selecting “DAMP 0” in the damping menu will give the fastest response. For optimal performance, “DAMP 0” is not recommended with turndown ranges exceeding 30:1.

Transmitter Response Time

With damping set to 0 s, the transmitter response time is less than 100 ms for a 63% response to a pressure step change.

Minimum Allowable Absolute Pressure vs. Transmitter Temperature

- ▶ With Silicone Fill Fluid, Full Vacuum: up to 121°C (250°F)
- ▶ With Inert Fill Fluid: refer to Figure 4

Figure 4. Minimum Allowable Absolute Pressure vs. Transmitter Temperature, Inert FC-43, 2.6 cSt at 25°C (77°F)

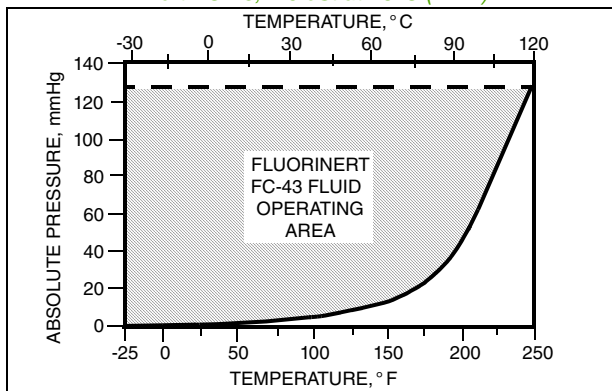

Current Outputs for Overrange, Fail, and Offline Conditions

Parameter	Current Outputs
Offline	Configurable between 3.6 and 21.0 mA
Sensor Failure	Configurable to Fail Lo or Fail Hi
Fail Lo	3.60 mA
Underrange	3.8 mA
Overrange	20.50 mA
Fail Hi	21.00 mA

Configuration and Calibration Data and Electronics Upgradeability

All factory characterization data and user configuration and calibration data are stored in the sensor (refer to Figure 5, Transmitter Functional Diagram). This means that the electronics module may be replaced, with one of like type, with a minimal amount of reconfiguration.

Module replacement can affect the accuracy by 0.10% of span.

Configuration Capability

Calibrated Range

- Input range within range limits
- See Table 4 for pressure units

Output Measurement #1 – Digital Primary Variable and 4 to 20 mA

- Mode: Linear
- Units: See Table 4 for pressure units

Output Measurement #2 – Digital Secondary Variable

- Mode: Linear
- Units: See Table 4 for pressure units

Figure 5. Transmitter Functional Block Diagram

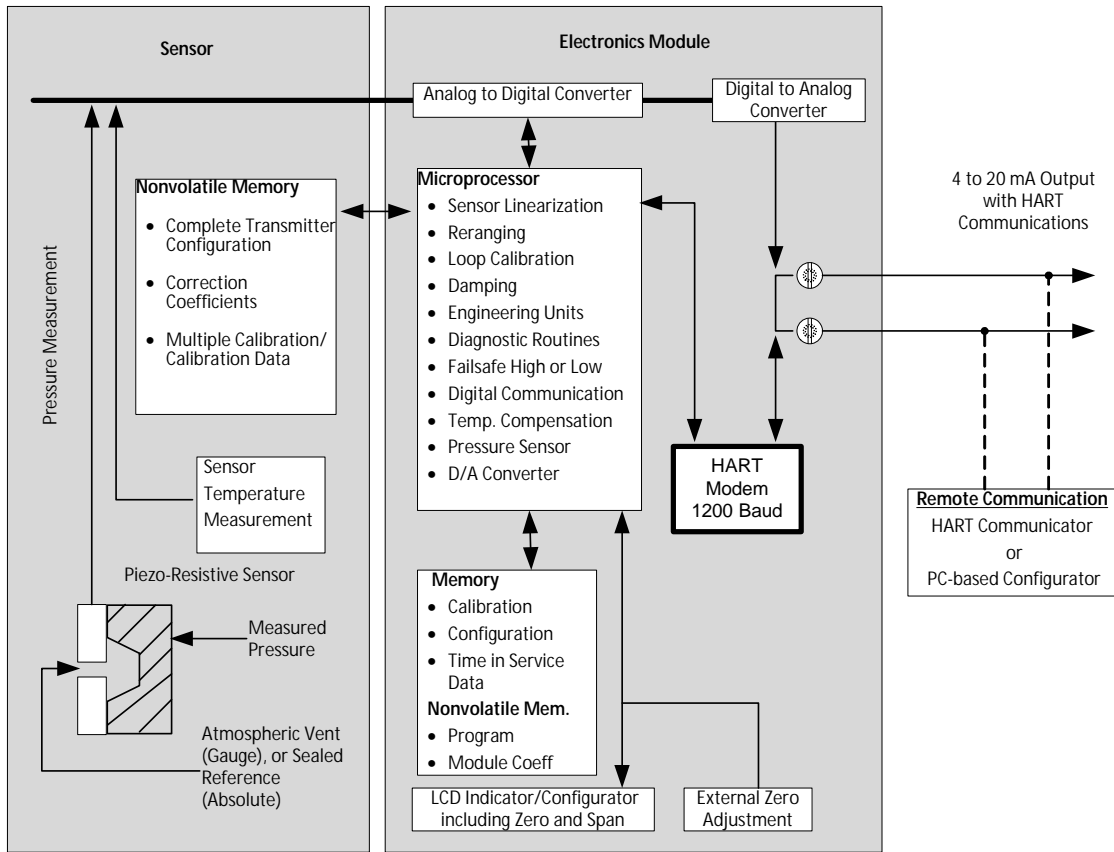

Communications

Transmitter communication is configurable for either analog or multidrop (fixed current) mode. Digital communication is provided in both modes based upon the FSK (Frequency Shift Keying) technique which alternately superimposes one of two different frequencies on the uninterrupted current carried by the two signal/power wires. See Figure 6 and Figure 7.

Analog Mode (4 to 20 mA)

The 4 to 20 mA output signal is updated multiple times per second. Digital communications between the transmitter and HART communicator is rated for distances up to 3050 m (10,000 ft). The communications rate is 1200 baud and requires a minimum loop load of 250 ohms.

Multidrop Mode (Fixed Current)

This mode supports communications with up to 15 transmitters on a single pair of signal/power wires. The output signal is updated 4 times per second and carries not only the pressure measurement, but also the sensor and electronics temperatures. Communication between the transmitter and system, or between the transmitter and communicator or configurator, is rated for distances up to 1525 m (5000 ft). The communications rate is 1200 baud and requires a minimum loop load of 250 ohms.

Table 4. Allowable Pressure Units for Calibrated Range (a)

psi	inH ₂ O	Pa	inWC60
bar	inHg	kPa	mWC4
mbar	ftH ₂ O	MPa	inWC4
g/cm ²	mmH ₂ O	torr	mmWC4
kg/cm ²	mmHg	atm	—

a. For absolute pressure, change psi to psia and MPa to MPaa etc.

Figure 6. 4 to 20 mA Output Functional Block Diagram Point-to-Point Communications

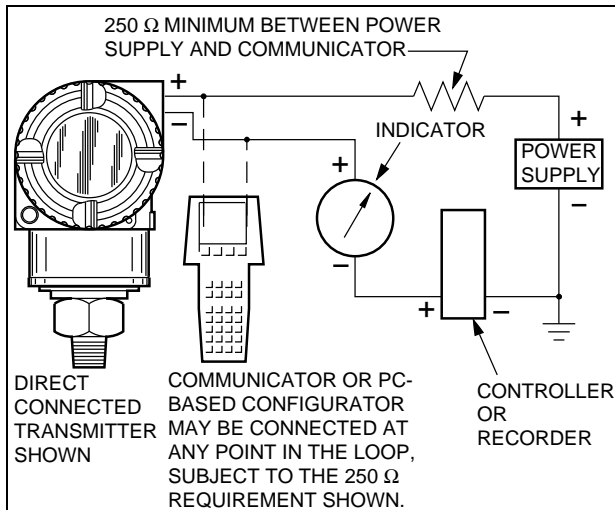
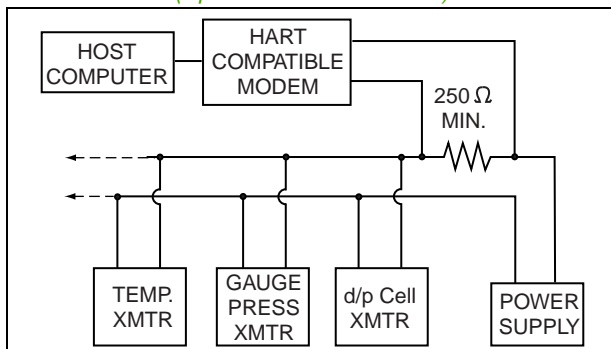

Figure 7. Typical Multidrop Functional Block Diagram (Up to Fifteen Transmitters)



Remote Communications

The HART communicator or PC-based configurator has full access to the “Display” and “Display and Reconfigure” items listed below. It may be connected to the communications wiring loop, and does not disturb the mA current signal. Plug-in connection points for the communicator are also provided on the transmitter terminal block.

The following information can be continuously displayed:

- ▶ Process Measurement in two formats
- ▶ Electronics and Sensor Temperatures
- ▶ mA Output
- ▶ Total number of days the transmitter has been powered up (not configurable)
- ▶ Number of days the transmitter has been powered up since the last Time in Service meter reset.

The following information can be continuously displayed and configured:

- ▶ Two Digital Outputs for Pressure
- ▶ Choice of Pressure Engineering Units
- ▶ Reranging without Pressure
- ▶ Zero and Span Calibration
- ▶ Electronic Damping
- ▶ Temperature Sensor Failure Strategy
- ▶ User Damping (Process Noise Damping)
- ▶ Failsafe Direction (Fail High or Fail Low)
- ▶ Tag, Descriptor, and Message
- ▶ Poll Address
- ▶ Loop Current Mode (Multidrop mode)
- ▶ FoxCal multiple calibration (Enable or Disable)
- ▶ External Zero (Enable or Disable)
- ▶ Date of Last Calibration
- ▶ Number of days the transmitter has been powered up since the last Time in Service meter reset.

Custom Factory Calibration (Option -C1)

If you want to override the default FoxCal multiple calibration behavior, specify Option -C1 to replace FoxCal with a custom 2-point calibration. Be sure to indicate the calibration range required in the sales order.

Table 5. Example of Custom Factory Calibration Option -C1

Parameter	Standard (Default) Configuration	Example of Custom Factory Calibration (Option -C1)
Calibrated Range Pressure EGU LRV URV	per sales order (a) per sales order (b) per sales order (c)	inH ₂ O 0 100
Measurement #1 Pressure EGU Output	per sales order (c) 4 to 20 mA	inH ₂ O 4 to 20 mA (d)
Measurement #2 Pressure EGU	per sales order (c)	inH ₂ O

- a. Units from Table 4. If not specified, factory default calibration is zero to maximum span; default units vary by sensor code.
- b. Within Span and Range Limits for selected sensor code.
- c. Same as Calibrated Range.
- d. Fixed current is used for multidrop applications.

Optional Full Factory Configuration (Option -C2)

For the transmitter to be custom configured by the factory, the user must fill out a data form. If this option is not selected, a standard (default) configuration will be provided. Refer to Table 6.

NOTE

Any of the configurable parameters in Table 6 can easily be changed using the HART communicator or PC-based configurator.

Table 6. Example of Custom Full Factory Configuration Option -C2

Parameter	Standard (Default) Configuration	Example of Custom Configuration Option -C2
Tagging Info. Tag (8 char. max.) Long Tag (32 char. max.) Descriptor (16 char. max.) Message (32 char. max.) HART Poll Address (0 to 63) Loop Current Mode	TAG TAG TAG NAME LOCATION 0 Enabled	PT101 PT101 WATER PRESS. BUILDING 2 0 Disabled (a)
Calibrated Range Pressure EGU LRV URV	per sales order (b) FoxCal or custom cal. LRV per sales order (c) FoxCal or custom cal. URV per sales order (d)	inH ₂ O 0 100
Measurement #1 Pressure EGU Output	per sales order (d) 4 to 20 mA	inH ₂ O 4 to 20 mA (e)
Measurement #2 Pressure EGU	per sales order (b)	inH ₂ O
Other Electronic Damping Failsafe Direction Failure Strategy Ext. Zero Option	0.25 s Upscale Continue Enabled	0.5 s Downscale Failsafe Disabled

- a. For multidrop configurations, the loop current mode is set to "fixed" or "disabled"; and the milliamp output is locked at a fixed value of 4.0 mA. For traditional point-to-point configurations, loop current mode is set to "active" or "enabled".
- b. Units from Table 4. If not specified, factory default calibration is zero to maximum span; default units vary by sensor code.
- c. Within Span and Range Limits for selected sensor code.
- d. Same as Calibrated Range.
- e. Fixed current is used for multidrop applications.

Optional LCD Indicator with Pushbuttons

Indicator provides:

- ▶ Two Lines: Five numeric characters on the top line (four when a minus sign is needed); and seven alphanumeric characters on the bottom line.
- ▶ Measurement readout: Value displayed on the top line and a units label displayed on the bottom line.
- ▶ Configuration and calibration prompts.

Two pushbuttons provide the following configuration and calibration prompts:

- ▶ Zero and Span settings, noninteractive to automatically set output to either 4 mA or 20 mA using the "NEXT" and "ENTER" pushbuttons.
- ▶ 4 and 20 mA Jog Settings, allowing the user to easily increment the mA output signal up or down in fine steps to match a value shown on an external calibrator.
- ▶ Forward or Reverse Output
- ▶ Damping Adjustment
- ▶ Enable/Disable Optional External Zero
- ▶ Temperature Sensor Failure Strategy
- ▶ Failsafe Action (High or Low)
- ▶ Units Label (Bottom Line of Display)
- ▶ Settable Lower and Upper Range Values for Transmission and Display (Top Line)
- ▶ Reranging without Pressure
- ▶ Percent (%) Output

Optional External Zero Adjustment

An external pushbutton mechanism (Figure 8) is isolated from the electronics compartment and magnetically activates an internal reed switch through the housing. This eliminates a potential leak path for moisture or contaminants to get into the electronics compartment. This zero adjustment can be disabled by a configuration adjustment.

Figure 8. LCD Indicator with Pushbuttons

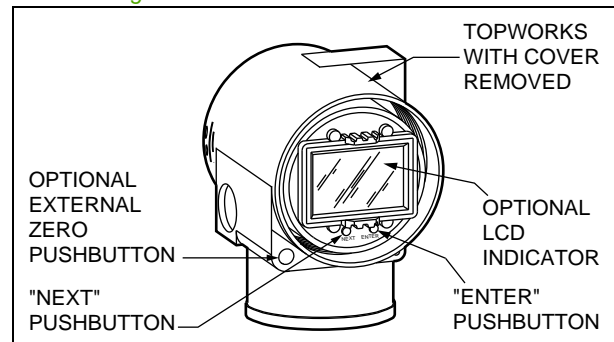

OPERATING, STORAGE, AND TRANSPORTATION CONDITIONS

Influence	Reference Operating Conditions	Normal Operating Conditions (a)	Operative Limits (a)	Storage and Transportation Limits
Process Connection Temp. ▶ with Silicone Fill Fluid ▶ with Inert Fill Fluid	▶ 24 ± 2°C (75 ± 3°F) ▶ 24 ± 2°C (75 ± 3°F)	▶ -29 to + 82°C (-20 to +180°F) ▶ -29 to + 82°C (-20 to +180°F)	▶ -46 and +121°C (-50 and +250°F) ▶ -29 and +121°C (-20 and +250°F)	▶ Not Applicable ▶ Not Applicable
Electronics Temperature ▶ with LCD Indicator (b)	▶ 24 ± 2°C (75 ± 3°F) ▶ 24 ± 2°C (75 ± 3°F)	▶ -29 to + 82°C (c) (-20 to +180°F) (c) ▶ -20 to + 82°C (c) (-4 to +180°F) (c)	▶ -40 and +85°C (c) (-40 and +185°F) (c) ▶ -40 and +85°C (c) (-40 and +185°F) (c)	▶ -54 and +85°C (-65 and +185°F) ▶ -54 and +85°C (-65 and +185°F)
Relative Humidity (d)	50 ± 10%	0 to 100%	0 and 100%	0 and 100% Noncondensing
Supply Voltage - mA Output	30 ± 0.5 V dc	11.5 to 42 V dc (e)	11.5 and 42 V dc (e)	Not Applicable
Output Load - mA Output	650 Ω	0 to 1450 Ω	0 and 1450 Ω	Not Applicable
Vibration	1 m/s ² (0.1 “g”)	With Aluminum Housing: Per IEC 60770 for “field with high vibration level or pipeline with high vibration level”, 0.42 mm peak to peak displacement from 10 to 60 Hz, 3 “g” constant acceleration input over a frequency range of 60 to 1000 Hz. With 316SST housing: Per IEC 60770 for “field with general application or pipeline with low vibration level, 0.30 mm peak to peak displacement from 10 to 60 Hz, 2 “g” constant acceleration input over a frequency range of 60 to 1000 Hz.	11 m/s ² (1.1 “g”) from 2.5 to 5 Hz (in shipping package)	
Mounting Position	Upright	Upright	No Limit	Not Applicable

- a. Normal Operating Conditions and Operative Limits are defined per ANSI/ISA 51.1-1979 (R1993).
- b. Although the LCD will not be damaged at any temperature within the “Storage and Transportation Limits,” updates will be slowed and readability decreased at temperatures outside the “Normal Operating Conditions.”
- c. Refer to “Electrical Safety Specifications” on page 17 for a restriction in ambient temperature limits with certain electrical approvals/certifications.
- d. With topworks covers on and conduit entrances sealed.
- e. 11.5 V dc can be reduced to 11 V dc by using a plug-in shorting bar; see “Physical Specifications” on page 16.

PERFORMANCE SPECIFICATIONS

Zero-Based Calibrations; 316L ss or Co-Ni-Cr Diaphragms with Silicone Fluid for IGP10S and IAP10S; Under Reference Operating Conditions unless otherwise Specified; URL = Upper Range Limit and Span = Calibrated Span (a)

Accuracy (Includes Linearity, Hysteresis, and Repeatability)

Type	E and F Ranges	D Range
Digital Accuracy Normal Operating Spans	±0.05% of span for spans ≥ 1.25% of URL (a)	±0.05% of span for spans ≥ 3.33% of URL (a)
Digital Accuracy High Turndown Spans	±(0.000625*(URL/Span))% of span for spans < 1.25% of URL	±(0.001667*(URL/Span))% of span for spans < 3.33% of URL
Analog Accuracy Normal Operating Spans	±0.06% of span for spans ≥ 1.25% of URL (a)	±0.06% of span for spans ≥ 3.33% of URL (a)
Analog Accuracy High Turndown Spans	±[0.01+(0.000625*(URL/Span))]% of span for spans < 1.25% of URL	±[0.01+(0.001667*(URL/Span))]% of span for spans < 3.33% of URL

- a. The FoxCal multiple calibration feature maintains this accuracy for zero-based spans re-ranged down to 30:1 turndown (3.33% of URL) without the need for a span point recalibration. For non-zero based spans exceeding 10:1 turndown from URL and Normal Operating Spans exceeding 30:1 turndown from URL, a full two-point custom recalibration is recommended to ensure optimal performance.

Stability

Long term drift is ±0.15% of URL over a 10-year period (reference conditions).

Supply Voltage Effect

The output changes less than 0.005% of span for each 1 V change within the specified supply voltage requirements. See Figure 3.

Position Effect

The transmitter may be mounted in any position. Any zero effect caused by the mounting position can be eliminated by rezeroing. There is no span effect.

Ambient Temperature Effect

NOTE

For additional ambient temperature effect when pressure seals are used, see PSS 2A-1Z11 A.

Transmitters with Span Limit Codes D, E, and F

Total effect for a 28°C (50°F) change within Normal Operating Condition limits for Span Limit Codes D, E, and F is:

$$\pm (0.03\% \text{ URL} + 0.060\% \text{ Span})$$

Vibration Effect**With Aluminum Housing**

Per IEC 61298-3, Section 7, Table 2 for “field with high vibration level or pipeline with high vibration level”: 0.42 mm peak to peak displacement from 10 to 60 Hz, 3 “g” constant acceleration input over a frequency range of 60 to 1000 Hz. Total effect is less than 0.1% of URL per “g”

With Stainless Housing

Per IEC 61298-3, Section 7, Table 2 for “field with general application or pipeline with low vibration level”: 0.30 mm peak to peak displacement from 10 to 60 Hz, 2 “g” constant acceleration input over a frequency range of 60 to 1000 Hz. Total effect is less than 0.1% of URL per “g”

RFI Effect

The output error is less than 0.1% of span for radio frequencies in the range of 30 to 1000 MHz and field intensity of 30 V/m when the transmitter is properly installed with shielded conduit and grounding, and housing covers are in place (per IEC Std. 61000-4-3).

Switching and Indirect Lightning Transients

The transmitter can withstand a transient surge up to 2000 V common mode or 1000 V normal mode without permanent damage. The output shift is less than 1.0%. (Per ANSI/IEEE C62.41-1980 and IEC Std. 61000-4-5.)

PHYSICAL SPECIFICATIONS

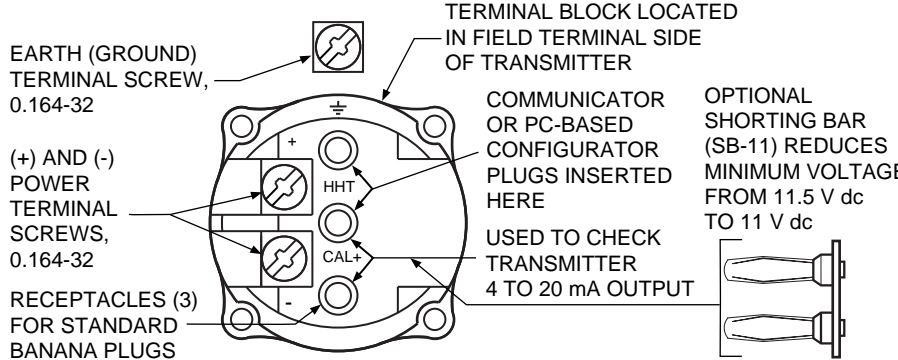
Description	Absolute and Gauge Pressure Transmitters IAP10S and IGP10S
Process Wetted Parts Materials (High Pressure Side) <ul style="list-style-type: none"> ▶ Process Connection ▶ Sensor Diaphragm 	<ul style="list-style-type: none"> ▶ 316L ss or nickel alloy (a) ▶ 316L ss, Co-Ni-Cr, or nickel alloy (a)
Reference Side Materials (Atmospheric Pressure Side)	IGP10S Transmitter: Silicon, Pyrex, RTV, and 316 ss IAP10S Transmitter: N/A
Sensor Fill Fluid	Silicone or Fluorinert
Electrical Housing and Housing Covers	Two compartments to separate electronics from field connections. Material is low copper (0.6% maximum) die-cast aluminum alloy with epoxy finish, or 316 ss.
Environmental Protection	The enclosure has the weatherproof, dust-tight, water-tight, and corrosion resistant rating of IP 66/67 as defined by IEC 60529, and provides the environmental and corrosion resistant protection rating of NEMA 4X.
Electronics Module	Printed wiring assemblies are conformally coated for moisture and dust protection.
Electrical Connections	1/2 NPT (Code 1) or M20 (Code 2) entrances on both sides of electronics housing, as specified. Unused entrance must be plugged to ensure moisture and RFI protection (Aluminum or 316 ss plug supplied).
Mounting Position	The transmitter may be mounted in any orientation.
Approximate Mass (Does not include seals. Refer to PSS 2A-1Z11 A for integral transmitter and seal systems)	Standard Transmitter 1.4 kg (3.1 lb) With 316 ss Housing Add 1.1 kg (2.4 lb) With LCD Indicator Option Add 0.2 kg (0.4 lb)
Field Terminal Connections	 <p> EARTH (GROUND) TERMINAL SCREW, 0.164-32 (+) AND (-) POWER TERMINAL SCREWS, 0.164-32 RECEPTACLES (3) FOR STANDARD BANANA PLUGS HHT CAL+ TERMINAL BLOCK LOCATED IN FIELD TERMINAL SIDE OF TRANSMITTER COMMUNICATOR OR PC-BASED CONFIGURATOR PLUGS INSERTED HERE USED TO CHECK TRANSMITTER 4 TO 20 mA OUTPUT OPTIONAL SHORTING BAR (SB-11) REDUCES MINIMUM VOLTAGE FROM 11.5 V dc TO 11 V dc </p>

a. Equivalent to Hastelloy® C-276.

ELECTRICAL SAFETY SPECIFICATIONS

The transmitters have been designed to meet the electrical safety descriptions listed in the table that follows. Contact Global Customer Support for information or status of testing laboratory approvals or certifications. See page 20 for availability of Electrical Safety Design Codes with particular transmitter structures, and refer to applicable instruction manual for application conditions and connectivity requirements.

Testing Laboratory, Types of Protection, and Area Classification	Application Conditions	Electrical Safety Design Code
ATEX intrinsically safe, Ex ia IIC	Temperature Class T4, Ta = -40°C to +80°C	AA
ATEX flameproof, Ex d IIC	Temperature Class T6, T85°C, Ta = -40°C to +75°C	AD
ATEX multiple certifications (includes ATEX Codes AA and AN)	Applies to Codes AA and AN	AM (a)
ATEX protection type n, Ex ic IIC	Temperature Class T4, Ta = -40°C to +80°C	AN
ATEX multiple certifications (includes ATEX Codes AA, AD and AN)	Applies to Codes AA, AN, and AD	AP (a)
INMETRO intrinsically safe, Ex ia IIC	Temperature Class T4, Ta = -40°C to +80°C	BA
INMETRO flameproof, Ex d IIC	Temperature Class T6, T85°C, Ta = -40°C to +75°C	BD
CSA intrinsically safe, Divisions Class I Division I, and Zone certified Ex ia	Temperature Class T4A at 40°C and T3C at 85°C maximum ambient	CA
CSA Divisions and zone certified flameproof Ex d IIC; also explosion proof, dust ignition-proof	T6, Maximum Ambient Temperature 75°C	CD
CSA Class I, Division 2 non-incendive, Zone certified Ex nA IIC	Temperature Class T4A at 40°C and T3C at 85°C maximum ambient	CN
IECEX intrinsically safe, Ex ia IIC	Temperature Class T4, Ta = -40°C to +80°C	EA
IECEX flameproof, Ex d IIC	Temperature Class T6, Ta = -40°C to +75°C	ED
IECEX multiple certifications, ia, ic, nA	Applies to Codes EA and EN	EM (a)
IECEX protection type n, Ex ic IIC	Temperature Class T4, Ta = -40°C to +80°C	EN
IECEX multiple certifications, ia, ic, and d	Applies to Codes EA, EN, and ED	EP (a)
FM Classes I, II and III Division 1 intrinsically safe, Zones AEx ia IIC	Temperature Class T4, Ta = -40°C to +80°C	FA
FM Classes I, II and III Division 1 explosion proof, dust-ignition proof, Zone approved AEx d IIC	Temperature Class T6 at 75°C and T5 at 85°C maximum ambient	FD
Classes I, II and III FM Division 2 non-incendive, Zone approved AEx nA IIC	Temperature Class T4, Ta = -40°C to +80°C	FN
Multi-marked for ATEX, CSA, and FM Intrinsically Safe Application	Applies to Codes FA, CA and AA	MA (b)
No certification		ZZ

- When selecting Safety Design Code AM, AP, EM, or EP, you must permanently mark (check off in rectangle block on data plate) one type of protection only (ia and ib, d, or n). Do not change this mark once it has been applied.
- When selecting Safety Design Code MA, you must permanently mark (check off in rectangular block on data plate) intrinsically safe certifications for ATEX, CSA, or FM, as applicable. Do not change this mark once it has been applied.

MODEL CODE: IAP10S AND IGP10S TRANSMITTERS

Description					Model
Intelligent Electronic Direct Connected Intelligent Absolute Pressure Transmitter					IAP10S
Intelligent Electronic Direct Connected Intelligent Gauge Pressure Transmitter					IGP10S
Electronics Versions and Output Signal					
Digital HART and 4 to 20 mA dc					-T
Structure Code - Select from one of the following six groups:					
1. Transmitter Only (no seals)					
Standard					
Process Connection	Diaphragm Material	Sensor Fill Fluid	External (Ext.) Connection Type	Internal (Int.) Connection Type	
316L ss	Co-Ni-Cr	Silicone	1/2 NPT Ext. Thread	1/4 NPT Int. Thread	20
316L ss	Co-Ni-Cr	Inert	1/2 NPT Ext. Thread	1/4 NPT Int. Thread	21
316L ss	316L ss	Silicone	1/2 NPT Ext. Thread	1/4 NPT Int. Thread	22
316L ss	316L ss	Inert	1/2 NPT Ext. Thread	1/4 NPT Int. Thread	23
316L ss	Nickel alloy (a)	Silicone	1/2 NPT Ext. Thread	1/4 NPT Int. Thread	30
316L ss	Nickel alloy (a)	Inert	1/2 NPT Ext. Thread	1/4 NPT Int. Thread	31
Nickel alloy (a)	Nickel alloy (a)	Silicone	1/2 NPT Ext. Thread	1/4 NPT Int. Thread	32
Nickel alloy (a)	Nickel alloy (a)	Inert	1/2 NPT Ext. Thread	1/4 NPT Int. Thread	33
316L ss	Co-Ni-Cr	Silicone	None	1/2 NPT Int. Thread (b)	34
316L ss	Co-Ni-Cr	Inert	None	1/2 NPT Int. Thread (b)	35
316L ss	316L ss	Silicone	None	1/2 NPT Int. Thread (b)	36
316L ss	316L ss	Inert	None	1/2 NPT Int. Thread (b)	37
316L ss	Nickel alloy (a)	Silicone	None	1/2 NPT Int. Thread (b)	38
316L ss	Nickel alloy (a)	Inert	None	1/2 NPT Int. Thread (b)	39
Gold-Plated					
Process Connection	Diaphragm Material	Sensor Fill Fluid	External (Ext.) Connection Type	Internal (Int.) Connection Type	
316L ss	Co-Ni-Cr	Silicone	None	1/2 NPT Int. Thread (b)	42
316L ss	Co-Ni-Cr	Inert	None	1/2 NPT Int. Thread (b)	43
316L ss	316L ss	Silicone	None	1/2 NPT Int. Thread (b)	44
316L ss	316L ss	Inert	None	1/2 NPT Int. Thread (b)	45
316L ss	Nickel alloy (a)	Silicone	None	1/2 NPT Int. Thread (b)	46
316L ss	Nickel alloy (a)	Inert	None	1/2 NPT Int. Thread (b)	47
316L ss	Co-Ni-Cr	Silicone	1/2 NPT Ext. Thread	1/4 NPT Int. Thread	70
316L ss	Co-Ni-Cr	Inert	1/2 NPT Ext. Thread	1/4 NPT Int. Thread	71
316L ss	316L ss	Silicone	1/2 NPT Ext. Thread	1/4 NPT Int. Thread	72
316L ss	316L ss	Inert	1/2 NPT Ext. Thread	1/4 NPT Int. Thread	73
316L ss	Nickel alloy (a)	Silicone	1/2 NPT Ext. Thread	1/4 NPT Int. Thread	80
316L ss	Nickel alloy (a)	Inert	1/2 NPT Ext. Thread	1/4 NPT Int. Thread	81
Nickel alloy (a)	Nickel alloy (a)	Silicone	1/2 NPT Ext. Thread	1/4 NPT Int. Thread	82
Nickel alloy (a)	Nickel alloy (a)	Inert	1/2 NPT Ext. Thread	1/4 NPT Int. Thread	83
2. Transmitter Prepared for Foxboro Model Coded Seals					
Process Connection	Diaphragm Material	Sensor Fill Fluid	Connection Type		
316L ss	316L ss	Silicone	Prepared for Foxboro Direct Connect Seal (c)		D1
316L ss	316L ss	Inert	Prepared for Foxboro Direct Connect Seal (c)		D2
316L ss	316L ss	Silicone	Prepared for Foxboro Remote Mount Seal (c)		S3
316L ss	316L ss	Inert	Prepared for Foxboro Remote Mount Seal (c)		S4

MODEL CODE: IAP10S AND IGP10S TRANSMITTERS

MODEL CODE: IAP10S AND IGP10S TRANSMITTERS

Description					Model	
3. Transmitters Prepared for non-Foxboro Seals						
Process Connection	Diaphragm Material	Sensor Fill Fluid	Connection Type			
316L ss	316L ss	Silicone	Prepared for Remote Mount Seal (d)		SC	
316L ss	316L ss	Inert	Prepared for Remote Mount Seal (d)		SD	
4. Flameproof Transmitter Only (no seals)						
Process Connection	Sensor Material	Sensor Fill Fluid	External (Ext.) Connection Type	Internal (Int.) Connection Type		
316L ss	316L ss	Silicone	1/2 NPT Ext.Thread	1/4 NPT Int. Thread	52	
316L ss	316L ss	Inert	1/2 NPT Ext.Thread	1/4 NPT Int. Thread	53	
316L ss	Nickel alloy (a)	Silicone	1/2 NPT Ext.Thread	1/4 NPT Int. Thread	60	
316L ss	Nickel alloy (a)	Inert	1/2 NPT Ext.Thread	1/4 NPT Int. Thread	61	
Nickel alloy (a)	Nickel alloy (a)	Silicone	1/2 NPT Ext.Thread	1/4 NPT Int. Thread	62	
Nickel alloy (a)	Nickel alloy (a)	Inert	1/2 NPT Ext.Thread	1/4 NPT Int. Thread	63	
316L ss	316L ss	Silicone	None	1/2 NPT Int. Thread (b)	90	
316L ss	316L ss	Inert	None	1/2 NPT Int. Thread (b)	91	
316L ss	Nickel alloy (a)	Silicone	None	1/2 NPT Int. Thread (b)	92	
316L ss	Nickel alloy (a)	Inert	None	1/2 NPT Int. Thread (b)	93	
5. Flameproof Transmitter Prepared for Foxboro Model-Coded Seals						
Process Connection	Diaphragm Material	Sensor Fill Fluid	Connection Type			
316L ss	316L ss	Silicone	Prepared for Foxboro Direct Connect Seal (c)		D5	
316L ss	316L ss	Inert	Prepared for Foxboro Direct Connect Seal (c)		D6	
316L ss	316L ss	Silicone	Prepared for Foxboro Remote Mount Seal (c)		S5	
316L ss	316L ss	Inert	Prepared for Foxboro Remote Mount Seal (c)		S6	
6. Flameproof Transmitter Prepared for non-Foxboro Seals						
Process Connection	Diaphragm Material	Sensor Fill Fluid	Connection Type			
316L ss	316L ss	Silicone	Prepared for Remote Mount Seal (d)		SH	
316L ss	316L ss	Inert	Prepared for Remote Mount Seal (d)		SJ	
Span Limits (e) - Absolute or Gauge Pressure Units, as Applicable						
IAP10S			IGP10S			
psi	kPa	bar	psi	kPa	bar	
0.5 and 200	3.45 and 1379	0.035 and 14	0.5 and 200	3.45 and 1379	0.035 and 14	D
5 and 2000	34.5 and 13790	0.35 and 138	5 and 2000	34.5 and 13790	0.35 and 138	E
N/A	N/A	N/A	100 and 6000	690 and 41369	6.89 and 414	F
Conduit Connection and Housing Material						
1/2 NPT Conduit Connection, Aluminum Housing					1	
1/2 NPT Conduit Connection, 316 ss Housing					3	
M20 Conduit Connection, Both Sides, Aluminum Housing					5	
M20 Conduit Connection, Both Sides, 316 ss Housing					6	

MODEL CODE: IAP10S AND IGP10S TRANSMITTERS

<u>Description</u>	<u>Model</u>
Electrical Safety (Also See "Electrical Safety Specifications" on page 17)	
ATEX intrinsically safe, Ex ia IIC	AA
ATEX flameproof, Ex d IIC (f)	AD
ATEX multiple certifications (includes ATEX Codes AA and AN)	AM
ATEX protection type n, Ex ic IIC	AN
ATEX multiple certifications (includes ATEX Codes AA, AD and AN) (f)	AP
INMETRO intrinsically safe, Ex ia IIC	BA
INMETRO flameproof, Ex d IIC (f)	BD
CSA intrinsically safe, Zone certified Ex ia	CA
CSA zone certified flameproof Ex d IIC; also explosion proof, dust ignition-proof (f)	CD
CSA non-incendive, Zone certified Ex nA IIC	CN
IECEX intrinsically safe, Ex ia IIC	EA
IECEX flameproof, Ex d IIC (f)	ED
IECEX multiple certifications, ia, ic	EM
IECEX protection type n, Ex ic IIC	EN
IECEX multiple certifications, ia, ic, and d (f)	EP
FM Classes I, II and III Division 1 intrinsically safe, AEx ia IIC	FA
FM Classes I, II and III Division 1 explosion proof, dust-ignition proof, Zone approved AEx d IIC (f)	FD
Classes I, II and III FM Division 2 non-incendive, Zone approved AEx nA IIC	FN
Multi-marked for ATEX, CSA, and FM Intrinsically Safe Application	MA
No certification	ZZ
Optional Selections	
Mounting Bracket Sets	
Painted Steel Bracket with Plated Steel Bolts, 1/2 NPT (g) (h)	-M1
Stainless Steel Bracket with Stainless Steel Bolts, 1/2 NPT (g) (h)	-M2
Painted Steel Bracket with Plated Steel Bolts, M20 (g) (i)	-M5
Stainless Steel Bracket with Stainless Steel Bolts, M20 (g) (i)	-M6
Stainless Steel Bracket for Flameproof Sensor Structures (j)	-M7
Painted Steel Bracket for Flameproof Sensor Structures (j)	-M8
Digital Indicator with Pushbuttons	
Digital Indicator, Pushbuttons, and Window Cover	-L1
Vent Screw and Block & Bleed Valve	
316 ss Vent Screw in Process Connection (k) (l) (m)	-V1
Block and Bleed Valve, Carbon Steel (k) (n)	-V2
Block and Bleed Valve, 316 ss (k) (n)	-V3
Block and Bleed Valve, 316 ss with Monel Trim, NACE approved (k) (l) (n)	-V4
Conduit Thread Adapters	
Brass Cable Gland (h)	-A1
M20 Connector (h)	-A3
Electronics Housing Features	
External Zero Adjustment	-Z1
Custody Transfer Lock and Seal	-Z2
External Zero Adjustment and Custody Transfer Lock and Seal	-Z3
Factory Configuration	
Custom Factory Calibration	-C1
Full Factory Configuration (Requires Configuration Form to be filled out)	-C2

MODEL CODE: IAP10S AND IGP10S TRANSMITTERS

Description	Model
Cleaning and Preparation	
Unit Degreased - for Silicone Filled Sensors Only (o)	-X1
Cleaned and Prepared for Oxygen Service - for Inert Filled Sensors Only (p)	-X2
B127 Cleaned and Prepared for Chlorine Service - with Structure Code 33 and 41 Only (q) (r)	-X3
<u>Instruction Books (Common MI, Brochure, and Full Documentation Set on DVD is Standard)</u>	
Without Instruction Book and DVD - Only "Getting Started" Brochure is supplied	-K1
<u>Optional Manifold Configurations</u>	
Manifold mounted to transmitter and pressure tested	-H1
(1.5 times transmitter range or 1.5 times manifold rating, whichever is less)	
Manifold mounted to transmitter and pressure tested (certificate)	-H2
<u>Miscellaneous Optional Selections</u>	
1/2 B Manometer Process Connection (s)	-G
1/2 Process Connection (1/2 NPT to R 1/2 Adapter) (s)	-R
Supplemental Customer Tag (Stainless Steel Tag wired onto Transmitter)	-T

- a. Equivalent to Hastelloy® C-276.
- b. Not available with Option Codes -V1, -V2, -V3, or -V4.
- c. Structure codes D1, D2, S3, S4, D5, D6, S5, and S6 are prepared for Foxboro model coded seals. Specify a seal model code.
- d. Structure codes SC, SD, SH, and SJ are transmitter prepared for attachment of pressure seals by others. Do not specify Foxboro Seal Model Code.
- e. Span Limit Code F is not available for IAP10S.
- f. Requires Structure Code 52, 53, 60, 61, 62, 63, 90, 91, 92, 93, D5, D6, S5, S6, SH.
- g. Not available with Electrical Codes AD, AP, BD, CD, ED, EP, and FD.
- h. For use with Conduit Connection Codes 1 & 3 only.
- i. For use with Conduit Connection Codes 5 & 6 only.
- j. Requires Structure Codes 52, 53, 60, 61, 62, 63, 90, 91, 92, and 93.
- k. Not available with -G option.
- l. Not available with -X1 and -X2 options.
- m. Not available with Structure Codes 32, 33, D1, D2, S3, S4, SC, SD, D5, D6, S5, S6, SH, SJ, 62, 63, 82, and 83.
- n. Available with only Structure Codes 20, 21, 22, 23, 30, 31, 32, 33, 70, 71, 72, 73, 80, 81, 82, 83, 52, 53, 60, 61, 62, and 63.
- o. Only with Structure Codes 20, 22, 30, 32, 34, 36, 38, 40, 42, 44, 46, 48, 70, 72, 80, 82, 52, 60, 62, 90, and 92.
- p. Only with Structure Codes 21, 23, 31, 33, 35, 37, 39, 41, 43, 45, 47, 49, 71, 73, 81, 83, 53, 61, 63, 91, and 93.
- q. Only with Structure Codes 33 and 41.
- r. Not with Option Code -V1.
- s. Available with Structure Codes 20, 21, 22, 23, 30, 31, 52, 53, 60, 61, 70, 71, 72, 73, 80, and 81.

SUGGESTED RFQ SPECIFICATIONS

The manufacturer shall provide direct connected pressure transmitters featuring remote digital communications capability for measuring absolute or gauge pressure and transmitting a 4 to 20 mA output with a superimposed HART digital signal for use in a standard two-wire dc supply voltage system. These transmitters shall also be provided (as required) with direct connect pressure seals, or remote mount capillary connected pressure seals. The specifications for these transmitters are as follows:

Communication Protocol:	HART, 4 to 20 mA dc, and digital output signal.	
Remote Communications:	Must not interfere with output.	
Accuracy:	Digital Output: $\pm 0.050\%$ of calibrated span. 4 to 20 mA Output: $\pm 0.060\%$ of calibrated span.	
RFI Protection:	0.1% error between 30 and 1000 MHz at 30 V/m field intensity	
Proof Pressure:	120, 1200, 11,500, or 22,000 psi for direct connected transmitters; as specified.	
Span Limits:	IAP10S: From 0.5 to 2000 psi IGP10S: From 0.3 to 6000 psi For standard direct connected transmitters; as specified; or SI and Metric equivalents	
Electronics Housing:	IEC IP67 (NEMA 4X); 316 ss or aluminum housing with Epoxy finish; two compartments (field wiring and electronics); housing sealed with O-rings for double protection against moisture or other contaminants.	
Modular Electronics:	Easily replaceable modular electronics; optional integral LCD Digital Indicator with on-board configuration pushbuttons.	
Mounting:	Direct to process.	
Process Connection:	IAP10S/IGP10S Transmitters: Direct to process piping or pressure seal with 1/2 NPT male and female; optional Rc 1/2 or G 1/2 B external threads to process piping. Internal 1/4 NPT thread also provided as plumbing connection to process; or prepared for a direct connect seal or capillary connected seal.	
Sensor Materials:	Co-Ni-Cr, 316L ss, and nickel alloy (a) for IAP10S/IGP10S transmitters.	
Electrical Classification:	Nonincendive for Class I and Class II, Division 2 locations; intrinsically safe or explosionproof for Class I and Class II, Division 1 locations. Versions available to meet Agency flameproof and zone requirements; comply with applicable European Union Directives.	
Approximate Mass:	Direct Connected Transmitter:	1.4 kg (3.1 lb)
	With 316 ss Electronics Housing:	Add 1.1 kg (2.4 lb)
	With Optional LCD Indicator:	Add 0.2 kg (0.4 lb)
	With Pressure Seals:	See PSS 2A-1Z11 A
Model Code:	IGP10S or IAP10S Direct Connected Gauge or Absolute Pressure Transmitters all with HART Communication Protocol; with or without pressure seals; or equivalent.	

a. Equivalent to Hastelloy® C-276.

DIMENSIONS – NOMINAL

mm
in

IAP10S AND IGP10S DIRECT CONNECTED TRANSMITTERS

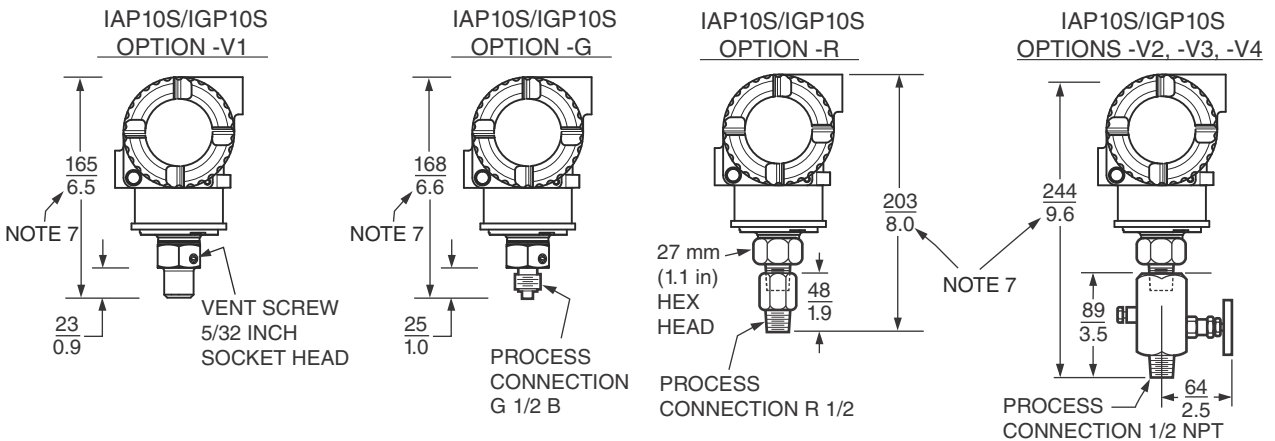
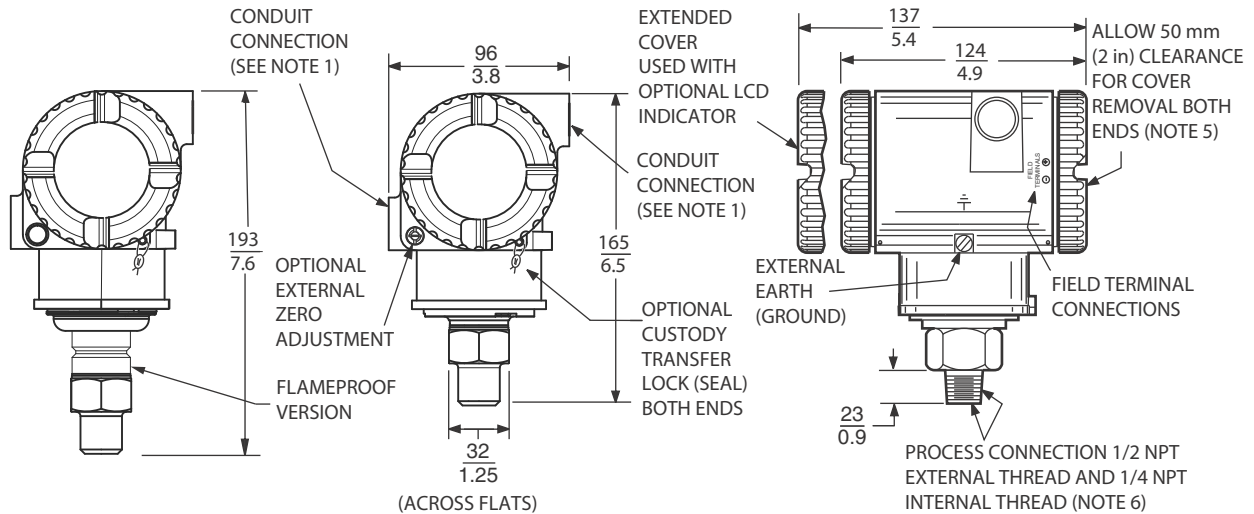

NOTES

1. CONDUIT CONNECTION 1/2 NPT OR M20, BOTH SIDES: PLUG UNUSED CONNECTION WITH METAL PLUG (SUPPLIED).
2. PROCESS CONNECTOR CAN BE REMOVED AND CONNECTION MADE DIRECTLY TO PROCESS COVER USING 1/4 NPT INTERNAL THREAD IN PROCESS COVER. NOTE THAT WITH PROCESS CONNECTION CODE "0", THERE IS NO CONNECTOR.
3. PROCESS COVER CAN BE INVERTED MAKING OPTIONAL SIDE VENT A SIDE DRAIN.
4. FOR USERS WHO DESIRE THE PROCESS CONNECTOR ON THE RIGHT SIDE, MERELY ROTATE TRANSMITTER 180° AND RELOCATE PROCESS CONNECTOR SHOWN TO THE RIGHT SIDE.
5. TOPWORKS ROTATABLE TO ANY POSITION WITHIN ONE TURN COUNTERCLOCKWISE OF FULLY TIGHTENED POSITION.
6. DO NOT USE THE 1/4 NPT INTERNAL THREAD TO DIRECT-CONNECT THE TRANSMITTER.
7. FOR FLAMEPROOF TRANSMITTERS, ADD 28 mm (1.1in) TO OVERALL HEIGHT DIMENSION. REFER TO DIMENSIONAL PRINT DP020-463 FOR FURTHER INFORMATION.

IAP10S/IGP10S WITH OPTIONS -M1 TO -M6

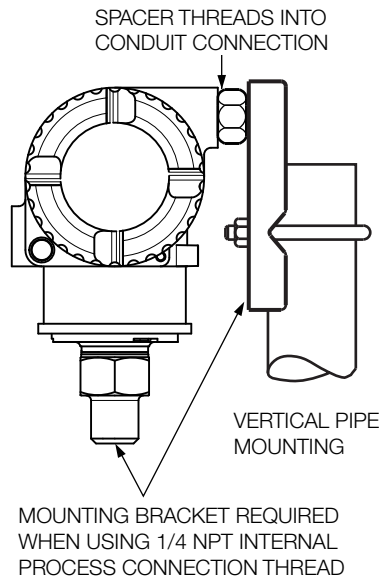

IAP10S/IGP10S WITH OPTIONS -M7 AND -M8

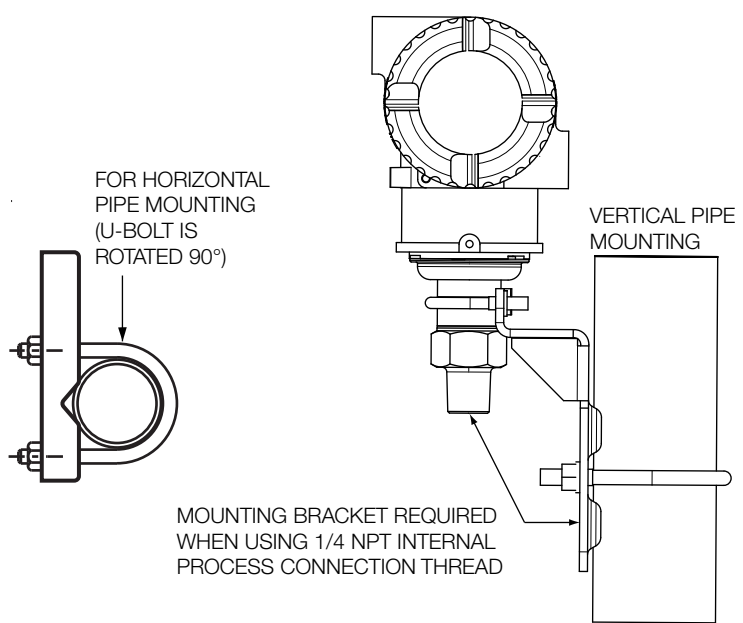

NOTES



ORDERING INSTRUCTIONS

1. Model Number(s) as follows:
 - ▶ Transmitter only if pressure seals are not selected
 - ▶ Both transmitter and pressure seal if a Foxboro pressure seal is selected.
See PSS 2A-1Z11 A.
2. Pressure Range (Lower Range Value and Upper Range Value in user-selected pressure units). Note: This also defines the Calibrated Pressure Range if the Custom Factory Calibration Option -C1 is specified.
3. Configuration Data Form when Full Factory Configuration Option -C2 is specified.
4. Options and Accessories not in Model Code (see PSS 2A-1Z9 E).
5. User Tag Data - Data Plate; 32 characters maximum. For additional tag data, specify Optional Supplemental Tag -T.
6. User Tag Data - Software (Database); up to 32 characters maximum (user configured).

OTHER FOXBORO PRODUCTS

The Foxboro product lines offer a broad range of measurement and instrument products, including solutions for pressure, flow, analytical, temperature, positioning, controlling, and recording.
For a list of these offerings, visit our web site at:

www.fielddevices.foxboro.com